

Shinbo

Indoor Sensors

DSW

Temperature

Humidity

Temperature
and Humidity

CO₂ Concentration



■ Sensor Type

Measurement Target	Measurement Range	Output	Lead Wire Color	Model	Power Supply
Temperature	0 to 50°C	100Ω / 0°C (Pt100) 3-wire type	RED, WHT, WHT	DSW-100-TR	No power supply
		4 to 20 mA DC (2-wires)	RED, WHT	DSW-100-TA	24 V DC ± 10%
		4 to 20 mA DC (4-wires)	RED, WHT, BRW, BLK	DSW-100-TA W4	
Humidity	5 to 90 %RH	4 to 20 mA DC (2-wires)	ORG, YLW	DSW-100-H	24 V DC ± 10%
		4 to 20 mA DC (4-wires)	ORG, YLW, BRW, BLK	DSW-100-H W4	
		0 to 1 V DC (4-wires)	ORG, YLW, BRW, BLK	DSW-100-HV W4	
Temperature Humidity	0 to 50°C 5 to 90 %RH	Temp: 100 Ω / 0°C (Pt100) 3-wire type Humi: 0 to 1 V DC (4-wires)	RED, WHT, WHT ORG, YLW, BRW, BLK	DSW-100-TRHV W4	24 V DC ± 10%
		Temp: 4 to 20 mA DC (2-wires) Humi: 4 to 20 mA DC (2-wires)	RED, WHT ORG, YLW	DSW-100-TAH	
		Temp: 4 to 20 mA DC (2-wires) Humi: 4 to 20 mA DC (4-wires)	RED, WHT ORG, YLW, BRW, BLK	DSW-100-TAH W4	
		Temp: 4 to 20 mA DC (2-wires) Humi: 0 to 1 V DC (4-wires)	RED, WHT ORG, YLW, BRW, BLK	DSW-100-TAHV W4	
CO ₂	360 to 2000 ppm (with Sensor Correction Function)	4 to 20 mA DC	RED, WHT	DSW-200-CO2-11□ (*)	24 V DC ± 10%
		0 to 20 mA DC	RED, WHT	DSW-200-CO2-12□ (*)	
		1 to 5 V DC	RED, WHT	DSW-200-CO2-13□ (*)	
		0 to 5 V DC	RED, WHT	DSW-200-CO2-14□ (*)	
		0 to 1 V DC	RED, WHT	DSW-200-CO2-15□ (*)	
	360 to 5000 ppm (with Sensor Correction Function)	4 to 20 mA DC	RED, WHT	DSW-200-CO2-21□ (*)	
		0 to 20 mA DC	RED, WHT	DSW-200-CO2-22□ (*)	
		1 to 5 V DC	RED, WHT	DSW-200-CO2-23□ (*)	
		0 to 5 V DC	RED, WHT	DSW-200-CO2-24□ (*)	
		0 to 1 V DC	RED, WHT	DSW-200-CO2-25□ (*)	
	0 to 2000 ppm	4 to 20 mA DC	RED, WHT	DSW-200-CO2-31□ (*)	
		0 to 20 mA DC	RED, WHT	DSW-200-CO2-32□ (*)	
		1 to 5 V DC	RED, WHT	DSW-200-CO2-33□ (*)	
		0 to 5 V DC	RED, WHT	DSW-200-CO2-34□ (*)	
		0 to 1 V DC	RED, WHT	DSW-200-CO2-35□ (*)	
	0 to 5000 ppm	4 to 20 mA DC	RED, WHT	DSW-200-CO2-41□ (*)	
		0 to 20 mA DC	RED, WHT	DSW-200-CO2-42□ (*)	
1 to 5 V DC		RED, WHT	DSW-200-CO2-43□ (*)		
0 to 5 V DC		RED, WHT	DSW-200-CO2-44□ (*)		
0 to 1 V DC		RED, WHT	DSW-200-CO2-45□ (*)		

(*) 0: Moisture-proof treatment unavailable, 1: Moisture-proof treatment available.

(Abbreviations: Temp: Temperature, Humi: Humidity)

■ Specifications

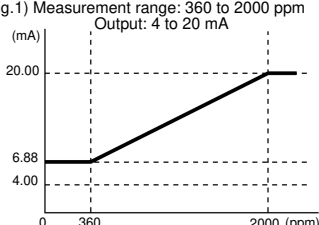
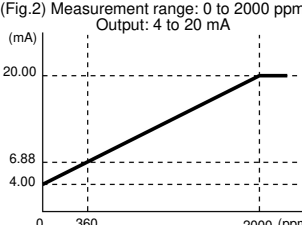
Output	Temperature	100 Ω / 0°C (Pt100) 3-wire type 4 to 20 mA DC (Linear conversion corresponding to 0 to 50°C) Maximum allowable load: 500 Ω max.
	Humidity	4 to 20 mA DC (Linear conversion corresponding to 0 to 100 %RH) Maximum allowable load: 500 Ω max. 0 to 1 V DC (Linear conversion corresponding to 0 to 100 %RH) Maximum allowable load: 500 Ω max.
CO ₂	CO ₂	4 to 20 mA DC, 0 to 20 mA DC, Maximum allowable load: 550 Ω max. 1 to 5 V DC, 0 to 5 V DC, Maximum allowable load: 5 kΩ minimum. 0 to 1 V DC, Maximum allowable load: 1 kΩ minimum.
	<Output of CO ₂ Sensor>	<p>(Fig.1) Measurement range: 360 to 2000 ppm Output: 4 to 20 mA</p>  <p>(Fig.2) Measurement range: 0 to 2000 ppm Output: 4 to 20 mA</p>  <p>For each range of CO₂ concentrations, linearly outputs corresponding to CO₂ concentration. However, if the "360 to 2000 ppm" or "360 to 5000 ppm" range is selected, and if the measured value is lower than 360 ppm, the value corresponding to 360 ppm will be output.</p>
Power Consumption	Temperature, and Humidity	2-wire type: Approx. 550 mW (4 to 20 mA DC output) 4-wire type: Approx. 3 W [100 Ω / 0°C (Pt100) output], Approx. 4 W (4 to 20 mA DC output)
	CO ₂	Approx. 3 W
Element Type	Temperature	RTD 100 Ω / 0°C (Pt100) (IEC 60751)
	Humidity	Electrostatic capacity variation type
Measurement Method	CO ₂	Non-dispersive infrared (NDIR)
Performance	Accuracy	
	Temperature	100 Ω / 0°C (Pt100) output: ± (0.1 + 0.0017 t)°C 4 to 20 mA DC output: ± 0.5°C Under the conditions of: Input power supply: 24 V, Load resistance: 250 Ω, Wind velocity: 0.15 m/s, Warm-up period: 60 minutes The output accuracy will be affected if the conditions above are changed.
Humidity	± 5 %RH (at 5 to 45°C), Outside of 5 to 45°C: Max. ± 8 %RH Under the conditions of: Input power supply: 24 V, Load resistance: 250 Ω, Wind velocity: 0.15 m/s, Warm-up period: 60 minutes The output accuracy will be affected if the conditions above are changed.	

	CO ₂	± (50 ppm + 3% of measured value). However, 300 ppm or less: ± 100 ppm Warm-up period: 30 minutes Note: Accuracy described here is the factory default.	Within 120 seconds
Sensor Correction	CO ₂	One cycle is equivalent to 45 days, and if the measured value drops below 400 ppm in the current cycle, the lowest value in the current cycle will become 400 ppm in the next cycle, and the difference between the lowest value and 400 ppm will be added to all other measured values in the next cycle. (Available when the "360 to 2000 ppm" or "360 to 5000 ppm" range is selected.)	
Dimensions	W90 x H90 x D32 mm (excluding lead wire)		
Weight	Temperature, Humidity	Approx. 90 g	
	CO ₂	Approx. 100 g	
Mounting	To the outlet box (inside wall), via outlet box cover: Mounting dimension: 66.7 mm (JIS C8340: 1999) (JIS: Japan Industrial Standards)		
Operating Environment	Temperature	Temperature: 0 to 50°C, Humidity: 5 to 95 %RH (non-condensing)	
	Humidity	Temperature: 0 to 50°C, Humidity: 5 to 90 %RH (non-condensing)	
	CO ₂	Temperature: 0 to 50°C, Humidity: 0 to 95 %RH (non-condensing)	
	[Caution] Do not use this sensor in an environment where dew condensation occurs. Do not use this sensor in an environment where chlorinated and sulfidizing gases are being generated, otherwise the thin film of the humidity sensor will deteriorate.		
Storage Environment	Temperature	Temperature: -20 to 60°C, Humidity: 5 to 95 %RH (non-condensing)	
	Humidity	Temperature: -20 to 60°C, Humidity: 5 to 90 %RH (non-condensing)	
	CO ₂	Temperature: -30 to 70°C, Humidity: 0 to 95 %RH (non-condensing) [Caution] Do not apply sustained pressure or shock to the cavity (gold-colored section) when handling (installing or storing) the sensor. If the sensor is exposed to a temperature lower than 0°C or higher than (and including) 40°C for several hours, sensor measurement value will be affected. If the sensor is stored at high humidity (90% or more) over a long period without power supplied, the initial measurement value may become slightly high until the humidity inside the cavity disappears.	
Accessories	Sensor main unit mounting screw: M3 x 4 (4 pieces), Mounting plate, Mounting plate screw: M4 x 8 (2 pieces), Spring washer (2 pieces), Instruction manual: 1 copy		

■ Wiring

Lead wire: 300 mm, Cross-section area: 0.5 mm²

Lead wire color: White (WHT), Red (RED), Black (BLK), Brown (BRW), Yellow (YLW), Orange (ORG)

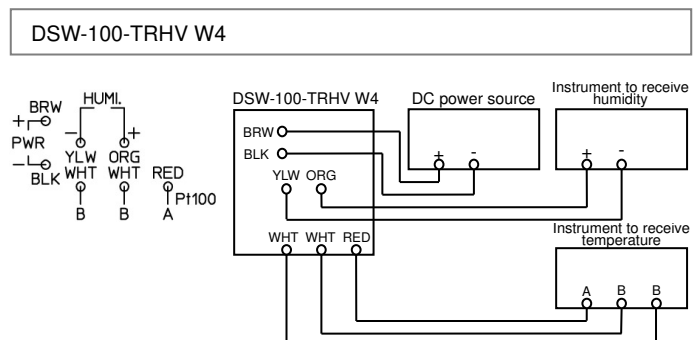
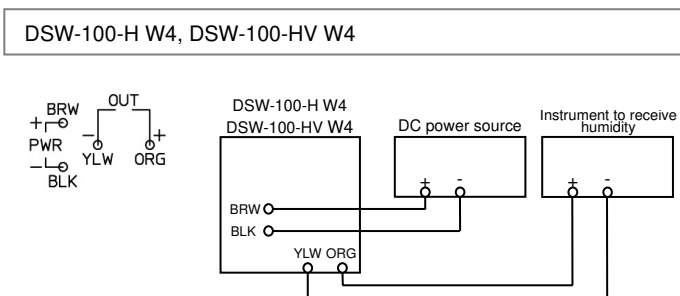
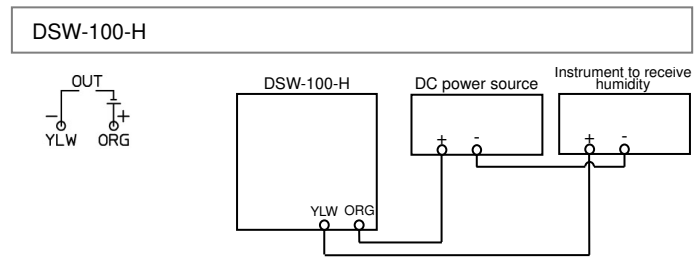
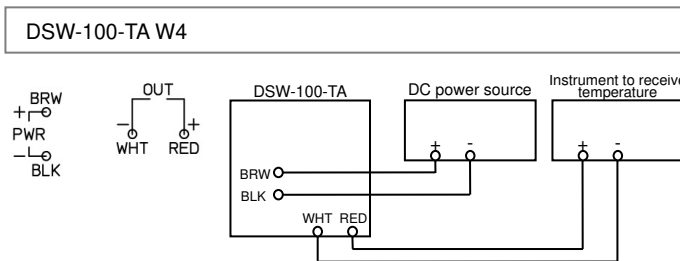
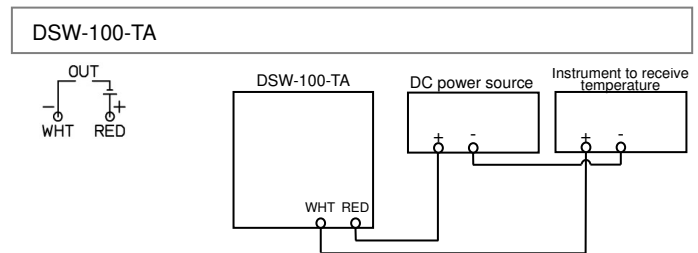
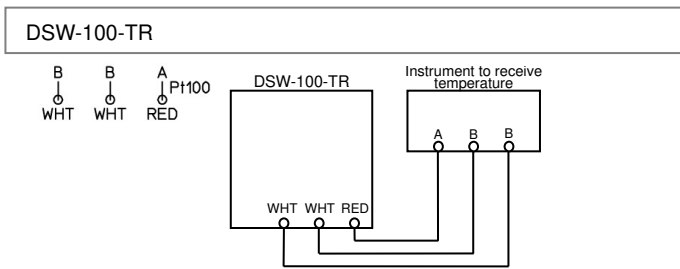

DSW-100-TAH

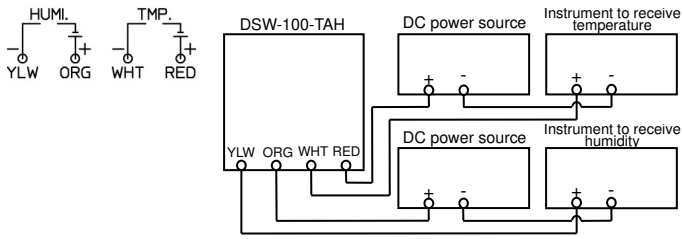

DSW-100-TAH W4, DSW-100-TAHV W4

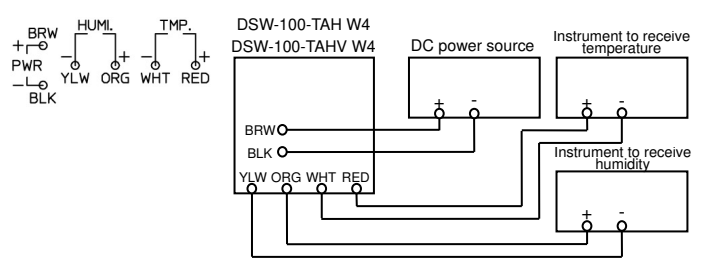

DSW-200-CO2-□□□

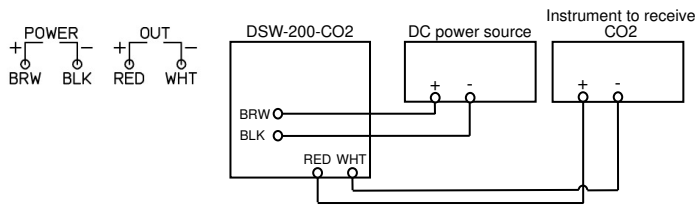

■ Dimensions (Scale: mm)

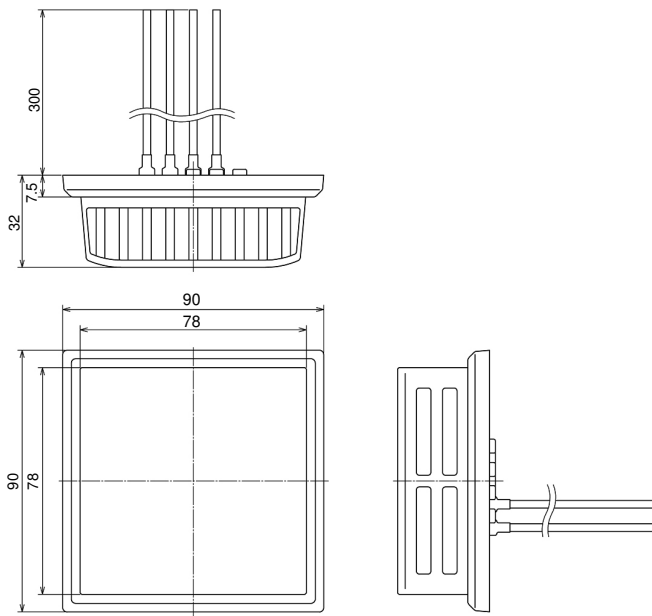

Mounting Plate

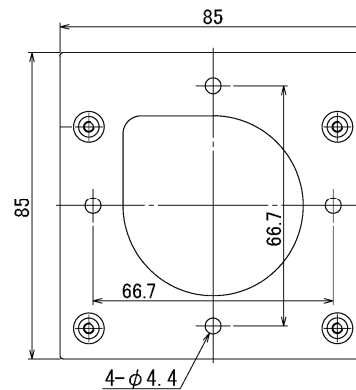

- To ensure safe and correct use, thoroughly read and understand the manual before using this instrument.
- This instrument is intended to be used for industrial machinery, machine tools and measuring equipment. Verify correct usage after purpose-of-use consultation with our agency or main office. (Never use this instrument for medical purposes with which human lives are involved.)
- External protection devices such as protection equipment against excessive temperature rise, etc. must be installed, as malfunction of this product could result in serious damage to the system or injury to personnel. Also proper periodic maintenance is required.
- This instrument must be used under the conditions and environment described in the manual. Shinko Technos Co., Ltd. does not accept liability for any injury, loss of life or damage occurring due to the instrument being used under conditions not otherwise stated in this manual.

Caution with respect to Export Trade Control Ordinance

To avoid this instrument from being used as a component in, or as being utilized in the manufacture of weapons of mass destruction (i.e. military applications, military equipment, etc.), please investigate the end users and the final use of this instrument. In the case of resale, ensure that this instrument is not illegally exported.

· This catalog is as of April 2021 and its contents are subject to change without notice.
 · Photos used in this catalog do not show unit in operating status.
 · If you have any inquiries, please consult us or our agency.

SHINKO TECHNOS CO., LTD.
OVERSEAS DIVISION

Head Office : 2-5-1, Senbahigashi, Minoo, Osaka, 562-0035, Japan
 Tel : +81-72-727-6100
 Fax : +81-72-727-7006
 URL : <https://shinko-technos.co.jp/e/>
 E-mail : overseas@shinko-technos.co.jp