

DIGITAL INDICATING CONTROLLER

FCS-23A

INSTRUCTION MANUAL

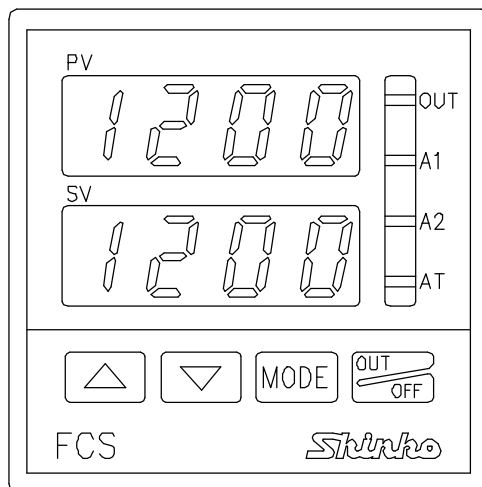

Shinko

Preface

Thank you for purchasing our Digital indicating controller FCS-23A.

This manual contains instructions for the mounting, functions, operations and notes when operating the FCS-23A.

To ensure safe and correct use, thoroughly read and understand this manual before using this controller. To prevent accidents arising from the misuse of this controller, please ensure the operator receives this manual.

Abbreviations used in this manual

Symbol	Term
PV	Process variable
SV	Desired value
MV	Output manipulated variable
OUT	Control output
AT	Auto-tuning

Characters used in this manual

Indication	+	0	1	2	3	4	5	6	7	8	9	°C	°F
Number, °C/°F	-1	0	1	2	3	4	5	6	7	8	9	°C	°F
Indication	A	b	c	d	E	F	G	H	I	J	k	L	ñ
Alphabet	A	B	C	D	E	F	G	H	I	J	K	L	M
Indication	n	o	P	q	r	s	T	U	V	W	X	Y	Z
Alphabet	N	O	P	Q	R	S	T	U	V	W	X	Y	Z

Notes

- This instrument should be used in accordance with the specifications described in the manual. If it is not used according to the specifications, it may malfunction or cause a fire.
- Be sure to follow the warnings, cautions and notices. If they are not observed, serious injury or malfunction may occur.
- Specifications of the FCS-23A and the contents of this instruction manual are subject to change without notice.
- Care has been taken to assure that the contents of this instruction manual are correct, but if there are any doubts, mistakes or questions, please inform our sales department.
- This instrument is designed to be installed through a control panel. If it is not, measures must be taken to ensure that the operator cannot touch power terminals or other high voltage sections.
- Any unauthorized transfer or copying of this document, in part or in whole, is prohibited.
- Shinko Technos CO., LTD. is not liable for any damage or secondary damage(s) incurred as a result of using this product, including any indirect damage.

SAFETY PRECAUTIONS (Be sure to read these precautions before using our products.)

The safety precautions are classified into categories: “Warning” and “Caution”.

Depending on the circumstances, procedures indicated by  Caution may cause serious results, so be sure to follow the directions for usage.



Warning

Procedures which may lead to dangerous conditions and cause death or serious injury, if not carried out properly.



Caution

Procedures which may lead to dangerous conditions and cause superficial to medium injury or physical damage or may degrade or damage the product, if not carried out properly.



Warning

- To prevent an electric shock or fire, only Shinko or other qualified service personnel may handle the inner assembly.
- To prevent an electric shock, fire or damage to the instrument, parts replacement may only be undertaken by Shinko or other qualified service personnel.



SAFETY PRECAUTIONS

- To ensure safe and correct use, thoroughly read and understand this manual before using this instrument.
- This instrument is intended to be used for industrial machinery, machine tools and measuring equipment. Verify correct usage after purpose-of-use consultation with our agency or main office. (Never use this instrument for medical purposes with which human lives are involved.)
- External protection devices such as protective equipment against excessive temperature rise, etc. must be installed, as malfunction of this product could result in serious damage to the system or injury to personnel. Also proper periodic maintenance is required.
- This instrument must be used under the conditions and environment described in this manual. Shinko Technos Co., Ltd. does not accept liability for any injury, loss of life or damage occurring due to the instrument being used under conditions not otherwise stated in this manual.

Caution with respect to Export Trade Control Ordinance

To avoid this instrument from being used as a component in, or as being utilized in the manufacture of weapons of mass destruction (i.e. military applications, military equipment, etc.), please investigate the end users and the final use of this instrument.

In the case of resale, ensure that this instrument is not illegally exported.

1. Installation Precautions



Caution

This instrument is intended to be used under the following environmental conditions (IEC61010-1): Overvoltage category II, Pollution degree 2

Ensure the mounting location corresponds to the following conditions:

- A minimum of dust, and an absence of corrosive gases
- No flammable, explosive gases
- No mechanical vibrations or shocks
- No exposure to direct sunlight, an ambient temperature of 0 to 50°C (32 to 122°F) that does not change rapidly, and no icing
- An ambient non-condensing humidity of 35 to 85%RH
- No large capacity electromagnetic switches or cables through which large current is flowing
- No water, oil or chemicals or where the vapors of these substances can come into direct contact with the unit
- Take note that ambient temperature of this unit - not the ambient temperature of the control panel - must not exceed 50°C (122°F) if mounted through the face of a control panel. Otherwise the life of electronic components (especially electrolytic capacitor) may be shortened.

Note: Avoid setting this instrument directly on or near flammable material even though the case of this instrument is made of flame-resistant resin.

2. Wiring Precautions



Caution

- Do not leave wire remnants in the instrument, as they could cause a fire and/or malfunction.
- Use the solderless terminal with an insulation sleeve in which an M3 screw fits when wiring the FCS-23A.
- The terminal block of this instrument is designed to be wired from the left side. The lead wire must be inserted from the left side of the terminal, and fastened with the terminal screw.
- Tighten the terminal screw within the specified torque. If excessive force is applied to the screw when tightening, the screw or case may be damaged.
- Do not apply a commercial power source to the sensor connected to the input terminal nor allow the power source to come into contact with the sensor, as the input circuit may be burnt out.
- This controller has no built-in power switch, circuit breaker or fuse. It is necessary to install them near the controller.
(Recommended fuse: Time-lag fuse, rated voltage 250V AC, rated current 2A)
- For a 24V AC/DC power source, do not confuse polarity when using direct current (DC).

3. Operation and Maintenance Precautions



Caution

- It is recommended that AT (auto-tuning) be performed during the trial run.
- Do not touch live terminals. This may cause electric shock or problems in operation.
- Turn the power supply to the instrument OFF when retightening the terminal and cleaning. Working on or touching the terminal with the power switched ON may result in severe injury or death due to electric shock.
- Use a soft, dry cloth when cleaning the instrument.
(Alcohol based substances may tarnish or deface the unit.)
- As the display section is vulnerable, do not strike or scratch it with a hard object or press hard on it.



Caution

- Setup by the DIP switch and Rotary switch inside of the controller is required before the power is turned on.
- Default values of the FCS-23A:
Sensor input: K
Control action: Fuzzy self-tuning PID, Heating control action
Alarm 1 (A1): No alarm action, No standby action
Unit °C/°F: °C
Program start Auto/Manual: Manual start

Refer to Chapter “3. Setup” (page 8).

-- CONTENTS --

	Page
1. Model	
1.1 Model -----	7
1.2 How to Read the Model Label -----	7
2. Name and Functions of Sections -----	8
3. Setup	
3.1 Removing the Internal Assembly -----	9
3.2 Switch Setting (Multi-function) -----	9
3.3 Insertion of the Internal Assembly -----	12
4. Mounting to the Control Panel	
4.1 Site Selection -----	13
4.2 External Dimensions (Scale: mm) -----	13
4.3 Panel Cutout (Scale: mm) -----	13
4.4 Mounting -----	14
5. Wiring -----	15
5.1 Terminal Arrangement -----	16
5.2 Wiring Examples -----	17
6. Settings	
6.1 Operation Flowchart -----	18
6.2 Settings	
6.2.1 Main Setting Mode -----	20
6.2.2 Sub Setting Mode -----	21
6.2.3 Auxiliary Function Setting Mode 1 -----	24
6.2.4 Auxiliary Function Setting Mode 2 -----	26
6.2.5 Program Mode -----	28
6.2.6 Control Output OFF Function -----	30
6.2.7 MV, Remaining Step Time Indication -----	30
7. Set Value Memory Function (SM Option) -----	31
8. Operation	
8.1 When Using the FCS-23A as a Temperature Controller -----	32
8.2 When Using the FCS-23A as a Simplified Programmable Controller -----	33
9. Action Explanations	
9.1 Standard Control Action -----	34
9.2 ON/OFF Control Action -----	35
9.3 Pattern End Action -----	35
9.4 Alarm 1 (A1), Alarm 2 (A2) Action -----	36
10. Control Actions	
10.1 Fuzzy Self-tuning -----	38
10.2 PID -----	38
10.3 AT of This Controller -----	39
11. Specifications	
11.1 Standard Specifications -----	40
11.2 Optional Specifications -----	43
12. Troubleshooting -----	45
13. Character Table -----	47

1. Model

1.1 Model

Alphanumeric characters underlined represent the control output (OUT), input or options.

[Example]

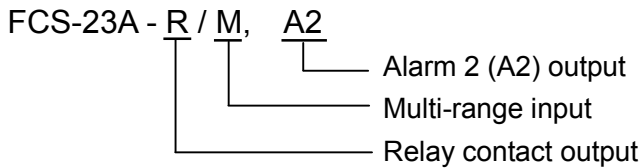

Standard specifications

FCS-2		3	A - <input type="checkbox"/> / <input type="checkbox"/> <input type="checkbox"/>	
Control action	3			PID control *1
Alarm (A)		A		Alarm types are selectable. *2
Control output (OUT)		R		Relay contact
		S		Non-contact voltage (for SSR drive)
		A		Direct current
Input		M		Multi-range *3

*1: PID, Fuzzy self-tuning PID, PD, ON/OFF control can be selected by internal DIP switch.

*2: 12 types of alarm plus No alarm action can be selected by internal DIP and Rotary switches.

*3: An input type can be selected by DIP and Rotary switches from thermocouple (10 types) and RTD (3 types).

Optional specifications

Code	Name	
A2	Alarm 2 (A2) output (including Pattern end 2 output)	
C5	RS-485	Serial communication
C	RS-232C	
SM	Set value memory number external selection	
LA	Loop break alarm output	
BL	Screw type mounting brackets	
BK	Color: Black	
IP	Drip-proof/Dust-proof	
TC	Terminal cover	

(For detailed options, see Section "11.2 Optional specifications".)

1.2 How to Read the Model Label

The model labels are attached to the case and the inner assembly.

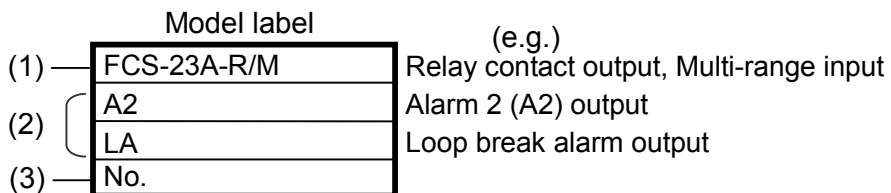

(1) Model, (2) Options, (3) Serial number

2. Name and Functions of Sections

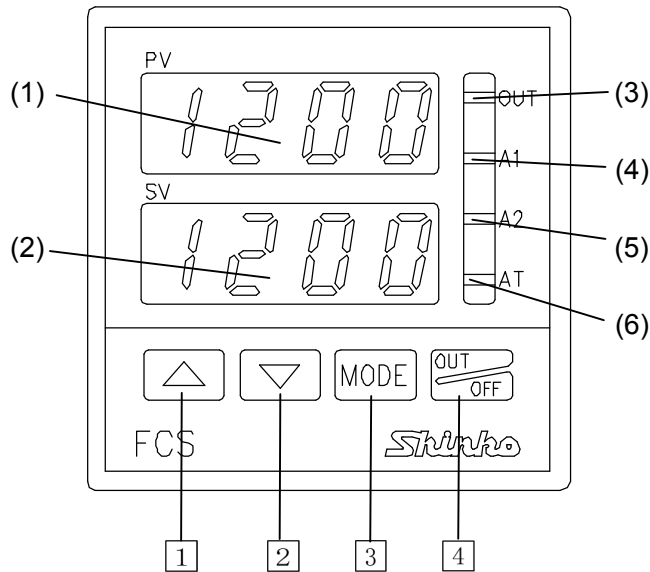

(Fig. 2-1)

Displays and indicators

(1) PV display (Red)

Indicates the PV or setting characters in the setting mode.

(2) SV display (Green)

Indicates the SV, MV, Time or set values in each setting mode.

(3) OUT indicator (Green)

Lights when OUT (control output) is ON.

(For Direct current output type, flashes corresponding to the MV in 125ms cycles.)

(4) A1 indicator (including Pattern end 1 output) (Red)

Lights when the Alarm 1 (A1) output or Pattern end 1 output is ON.

(5) A2 indicator (including Pattern end 2 output) (Red) (Option)

Lights when the Alarm 2 (A2) output or Pattern end 2 output is ON.

(6) AT indicator (Yellow)

Flashes during AT (auto-tuning).

Keys

- 1** ▲ Increase Key: Increases the numeric value on the SV display during setting mode.
- 2** ▼ Decrease Key: Decreases the numeric value on the SV display during setting mode.
- 3** MODE Mode Key: Switches a setting mode and registers set values.
To register each set (or selected) value, press this key.
- 4** OUT/OFF OUT/OFF Key: Performs the control output ON/OFF or Program control Start/Stop.
In any mode, if the OUT/OFF key is pressed for approx. 1 second, the Control output OFF function will work.
To release the function, press the key for 1 second.

3. Setup

3.1 Removing the Internal Assembly

Before the power supply to this instrument is turned on, draw the internal assembly out from the case in the direction indicated by the arrow by pushing the latch (bottom of the instrument) while holding the instrument by the top and bottom.

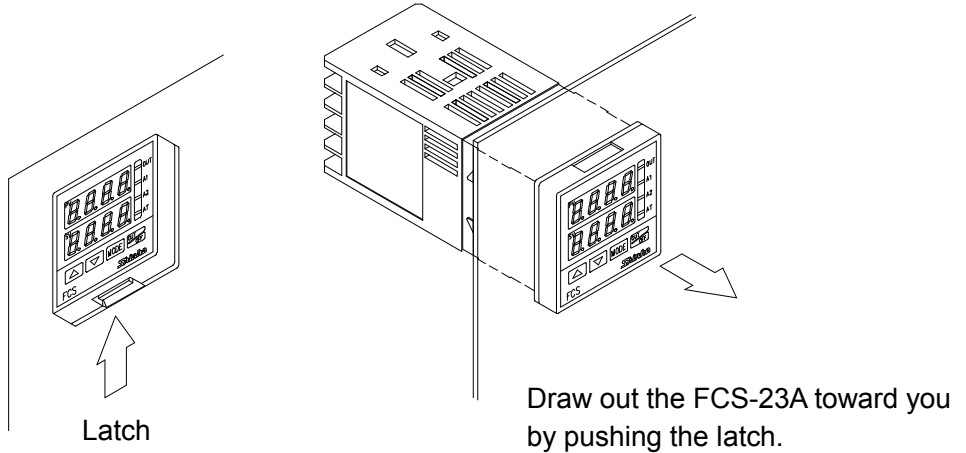

(Fig. 3.1-1)

3.2 Switch Setting (Multi-function)

Using a small flat blade screwdriver or tweezers, set the following with the DIP and Rotary switches.

Sensor input, Alarm 1 (A1) type, Alarm 2 (A2) type, Control action, Heating (reverse)/Cooling (direct) action, Alarm 1 (A1) standby and Alarm 2 (A2) standby actions, Unit °C/°F, Program start Auto/Manual

Rotary switch (SW301) will be equipped only when the A2 option is ordered.

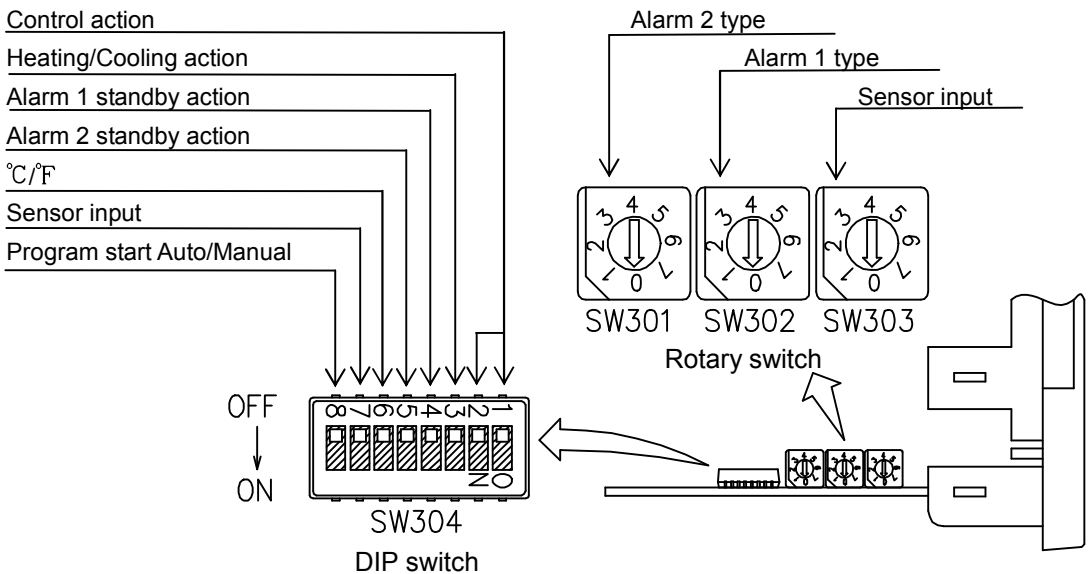

(Fig. 3.2-1)

The following items can be selected by the DIP switch (SW304).

Default value: All switches OFF

(Table 3.2-1)

Item	DIP SW304 No.	Selection	Switch status	
Control action	1 and 2	Fuzzy self-tuning PID control	No.1: OFF	No.2: OFF
		PID control	No.1: ON	No.2: OFF
		PD control	No.1: OFF	No.2: ON
		ON/OFF control	No.1: ON	No.2: ON
Heating/Cooling action	3	Heating (reverse) action	No.3: OFF	
		Cooling (direct) action	No.3: ON	
Alarm 1 (A1) standby action	4	No standby action	No.4: OFF	
		Standby action	No.4: ON	
Alarm 2 (A2) standby action (*1)	5	No standby action	No.5: OFF	
		Standby action	No.5: ON	
°C/°F	6	°C	No.6: OFF	
		°F	No.6: ON	
Sensor input (*2)	7	K, J, R, B, N, PL-II, Pt100, JPt100 (With decimal point)	No.7: OFF	
		S, E, T, C, Pt100 (Without decimal point)	No.7: ON	
Program start Auto/Manual (*3)	8	Manual start	No.8: OFF	
		Automatic start	No.8: ON	

(*1) The standby function will work only when the A2 option is ordered.

(*2) Use the Rotary switch (SW303) and DIP switch (SW304) together for sensor input selection.

(*3) **Program start Auto/Manual: For Program control**

Manual start: The preset program starts by pressing the  key.

Automatic start: The preset program automatically starts from Step 1 after 2 seconds of warm-up status after power-on.

Select a sensor type using the Rotary switch (SW303) and DIP switch (SW304).
Default value: K -200 to 1370°C

Note: If the input type is changed, Scaling high/low limit will become the altered input range high/low limit value.

(Table 3.2-2)

Rotary SW303 No.	DIP SW304 No. 7	Sensor type	Range (DIP SW304 No.6)	
			OFF	ON
0	OFF	K	-200 to 1370°C	-320 to 2500°F
1	OFF	J	-200 to 1000°C	-320 to 1800°F
2	OFF	R	0 to 1760°C	0 to 3200°F
3	OFF	B	0 to 1820°C	0 to 3300°F
4	OFF	PL-II	0 to 1390°C	0 to 2500°F
5	OFF	N	0 to 1300°C	0 to 2300°F
6	OFF	Pt100	-199.9 to 850.0°C	-199.9 to 999.9°F
7	OFF	JPt100	-199.9 to 500.0°C	-199.9 to 900.0°F
0	ON	S	0 to 1760°C	0 to 3200°F
1	ON	E	0 to 1000°C	0 to 1800°F
2	ON	T	-199.9 to 400.0°C	-199.9 to 750.0°F
3	ON	C (W/Re5-26)	0 to 2315°C	0 to 4200°F
7	ON	Pt100	-200 to 850°C	-320 to 1560°F

If DIP switch (SW304) No.7 is set to “ON”, do not set Rotary switch (SW303) No. 4, 5 and 6.

The alarm type and the pattern end output for Program control can be selected by the Rotary switches (SW302) and (SW301).

Rotary switch (SW301) will be equipped only when A2 option is ordered.

Rotary SW302: Alarm 1 (A1) type, Pattern end 1 output

Rotary SW301: Alarm 2 (A2) type, Pattern end 2 output

Note: If an alarm type is changed, the alarm set value becomes 0 (0.0).

Default value: No alarm action

(Table 3.2-3)

Alarm 1 (A1) type	Rotary SW302 No.	Alarm 2 (A2) type	Rotary SW301 No.
No alarm action	0	No alarm action	0
High limit alarm	1	High limit alarm	1
Low limit alarm	2	Low limit alarm	2
High/Low limits alarm	3	High/Low limits alarm	3
High/Low limit range alarm	4	High/Low limit range alarm	4
Process high alarm	5	Process high alarm	5
Process low alarm	6	Process low alarm	6
Pattern end 1 output	7	Pattern end 2 output	7

3.3 Insertion of the Internal Assembly

After the setup is completed, insert the internal assembly into the case.

Firmly insert the assembly until it is locked by the latch at the bottom of the instrument.

(There will be a clicking sound.)



Caution

Do not confuse the top and bottom of the internal assembly.

If inserting the assembly into the case by force in the wrong direction, the PCB may be damaged.

4. Mounting to the Control Panel

4.1 Site Selection

This instrument is intended to be used under the following conditions (IEC61010-1): Overvoltage category II, Pollution degree 2

Ensure the mounting location corresponds to the following conditions:

- (1) A minimum of dust, and an absence of corrosive gases
- (2) No flammable, explosive gases
- (3) No mechanical vibrations or shocks
- (4) No exposure to direct sunlight, an ambient temperature of 0 to 50°C (32 to 122°F) that does not change rapidly, and no icing
- (5) An ambient non-condensing humidity of 35 to 85%RH
- (6) No large capacity electromagnetic switches or cables through which large current flows
- (7) No water, oil or chemicals or where the vapors of these substances can come into direct contact with the unit
- (8) Take note that ambient temperature of this unit - not the ambient temperature of the control panel - must not exceed 50°C (122°F) if mounted through the face of a control panel. Otherwise the life of electronic components (especially electrolytic capacitor) may be shortened.

4.2 External Dimensions (Scale: mm)

One-touch type mounting brackets

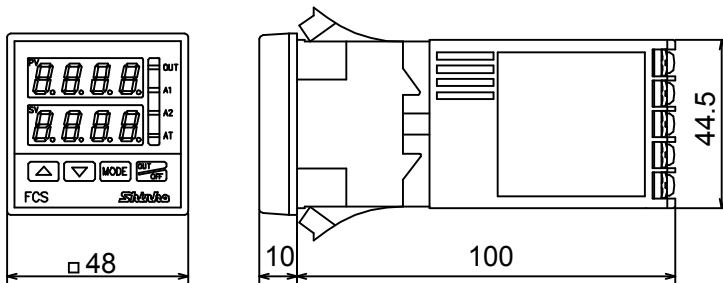

(Fig. 4.2-1)

Screw type mounting brackets

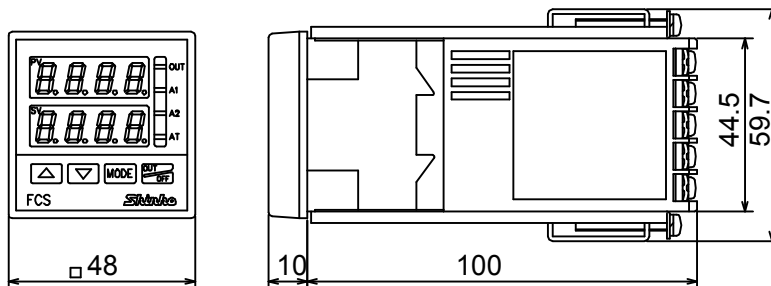

(Fig. 4.2-2)

4.3 Panel Cutout (Scale: mm)

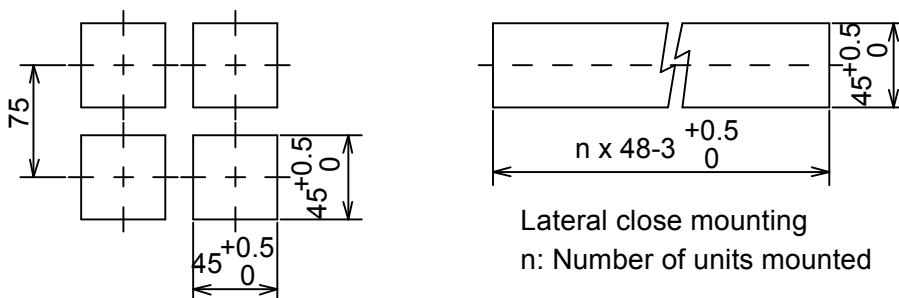

(Fig. 4.3-1)

4.4 Mounting



Caution

As the case is made of resin, do not use excessive force while screwing in the mounting bracket.

The torque should be 0.12N•m.

- **When using the One-touch type mounting bracket**

Mounting panel thickness: 1 to 3mm.

Mount one-touch mounting brackets ① to the instrument first, then insert the FCS-23A ② from the front of the panel.

If Soft front cover (FC-48-S) is used, the mounting panel thickness will be 1 to 2.5mm.

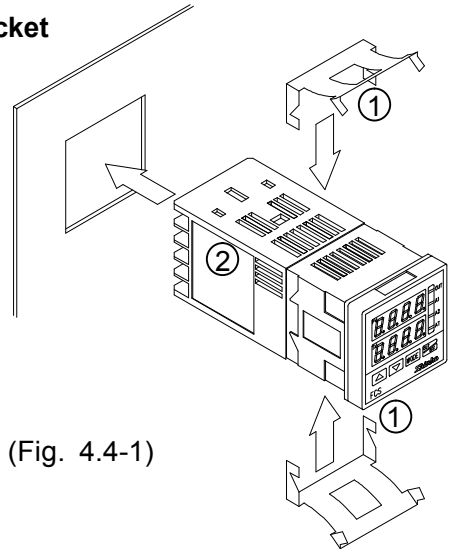

(Fig. 4.4-1)

- **When using the Screw type mounting bracket (Option code: BL)**

Mounting panel thickness: 1 to 8mm

If Soft front cover (FC-48-S) is used, mounting panel thickness will be 1 to 7.5mm.

Insert the FCS-23A from the front of the panel.

Attach the mounting brackets to the slots at the top and bottom of the case, and secure the controller in place with the screws provided.

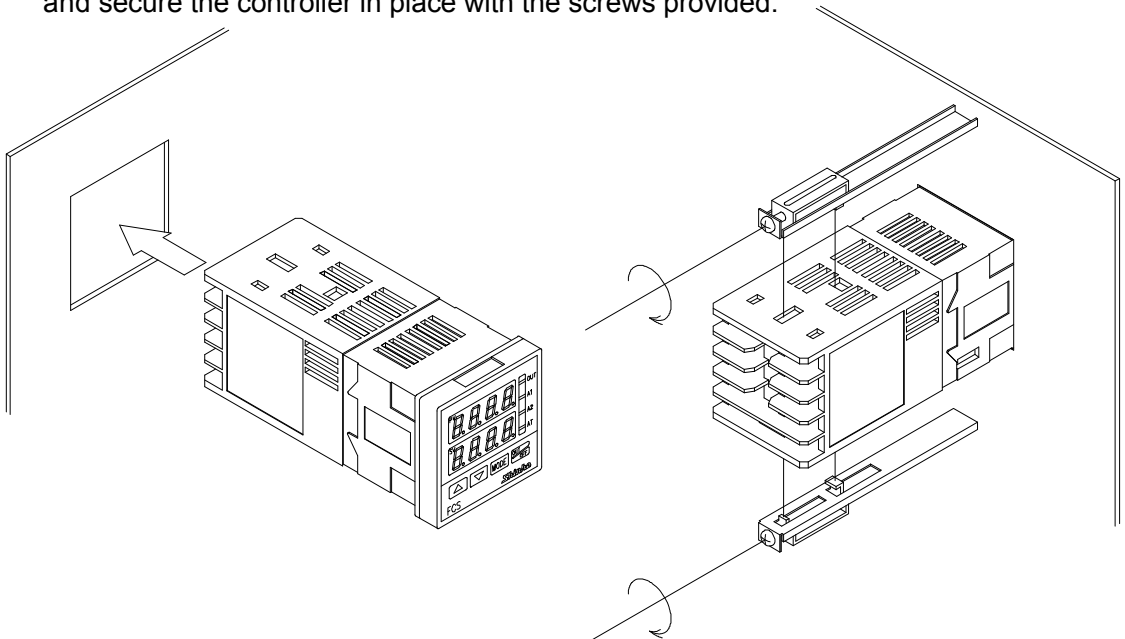

(Fig. 4.4-2)

5. Wiring

Warning

Turn the power supply to the instrument off before wiring or checking.

Working on or touching the terminal with the power switched on may result in severe injury or death due to electric shock.

Moreover, the instrument must be grounded before the power supply to the instrument is turned on.

Caution

- The terminal block of this instrument is designed to be wired from the left side. The lead wire must be inserted from the left side of the terminal, and fastened by the terminal screw.
- Use a thermocouple and compensating lead wire according to the sensor input specifications of this controller.
- Use a 3-wire RTD system according to the sensor input specifications of this controller.
- This controller does not have a built-in power switch, circuit breaker or fuse. Therefore, it is necessary to install them in a circuit externally, near the controller. (Recommended fuse: Time-lag fuse, rated voltage 250V AC, rated current 2A)
- For a 24V AC/DC power source, do not confuse polarity when using direct current (DC).
- When using a relay contact output type, externally use a relay according to the capacity of the load to protect the built-in relay contact.
- When wiring, keep the input wires (thermocouple, RTD, etc.) away from AC sources or load wires.
- Use a thick wire (1.25 to 2.0mm²) for grounding.

● Lead wire solderless terminal

Use a solderless terminal with an insulation sleeve in which an M3 screw fits as shown below.

The torque should be 0.63N•m.

Solderless terminal	Manufacturer	Model	Torque
Y type	Nichifu Terminal Industries CO.,LTD.	TMEV1.25Y-3	0.63N•m
	Japan Solderless Terminal MFG CO.,LTD.	VD1.25-B3A	
Ring type	Nichifu Terminal Industries CO.,LTD.	TMEV1.25-3	
	Japan Solderless Terminal MFG CO.,LTD.	V1.25-3	

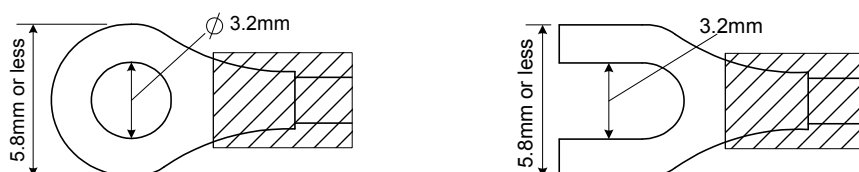

(Fig. 5-1)

5.1 Terminal Arrangement

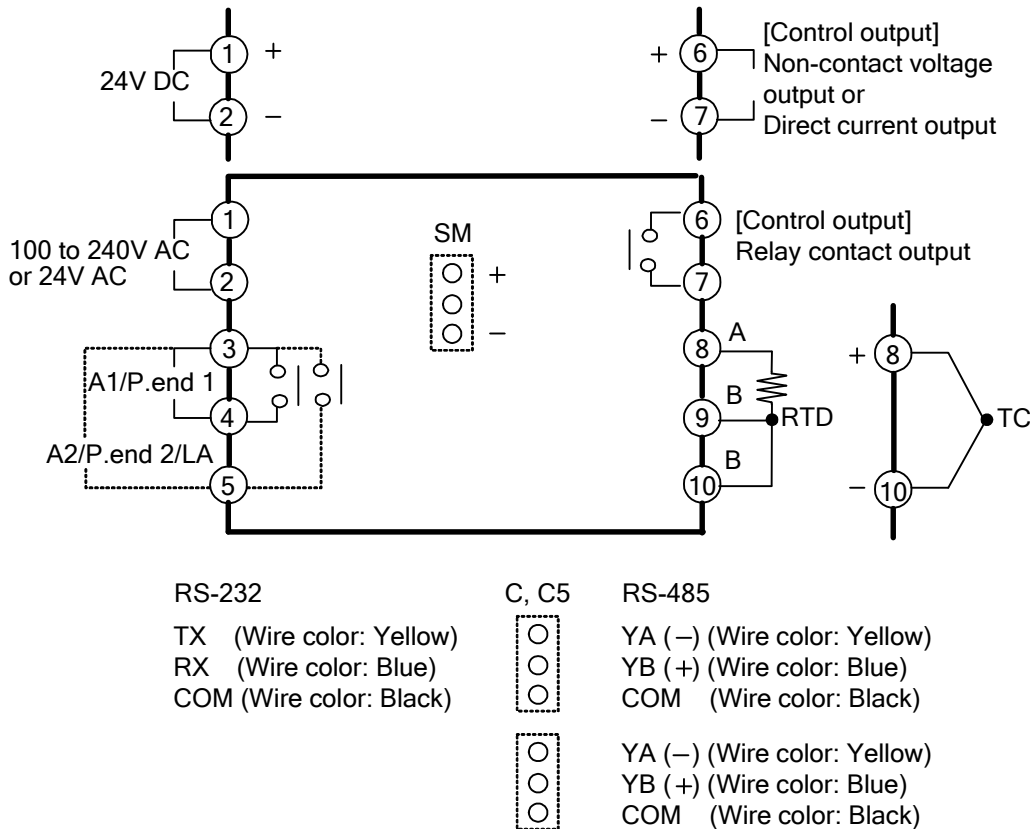

(Fig. 5.1-1)

- A1: Alarm 1 output
 A2: Alarm 2 output
 P. end 1: Pattern end 1 output
 P. end 2: Pattern end 2 output
 LA: Loop break alarm output
 SM: Set value memory number external selection
 C, C5: Serial communication

- Dotted lines show options, and no terminal is equipped unless specified.
- If Alarm 2 (A2 option) and Loop break alarm (LA option) are ordered together, they utilize common output terminals.
- Serial communication C/C5 option cannot be ordered in combination with the A2, LA or SM option.
 For Alarm 2, even if Alarm 2 (Pattern end 2) is ordered, there is no output. However, setting items, communication commands and the indicator are still available.

5.2 Wiring Examples

[FCS-23A-R/M]

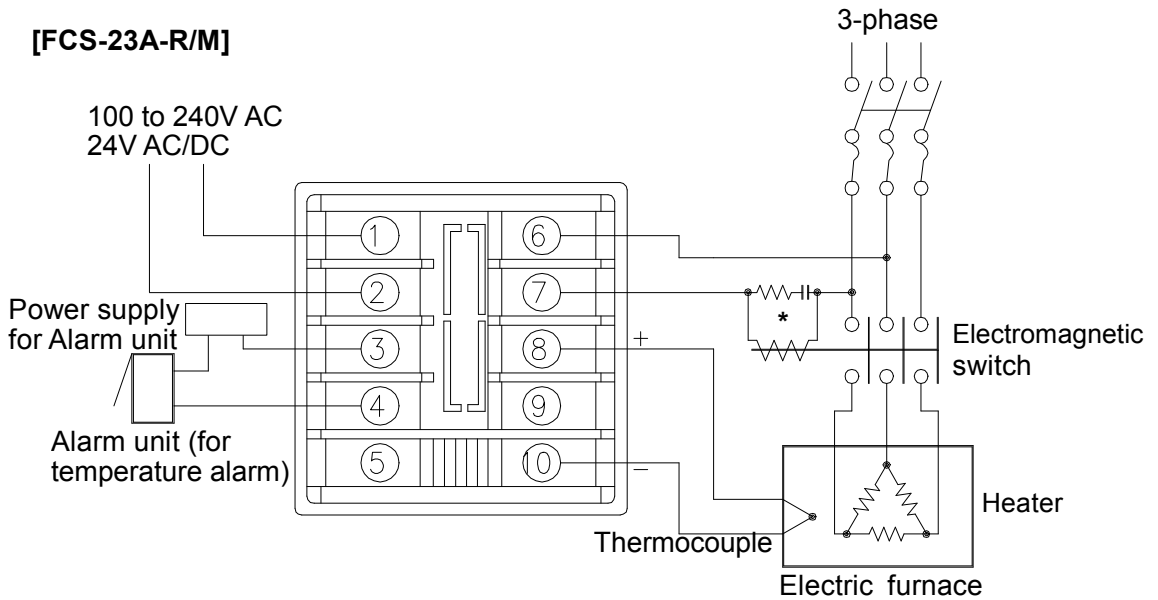

(Fig. 5.2-1)

* To prevent the unit from harmful effects of unexpected level noise, it is recommended that a surge absorber be installed between the electromagnetic switch coils.

[FCS-23A-S/M]

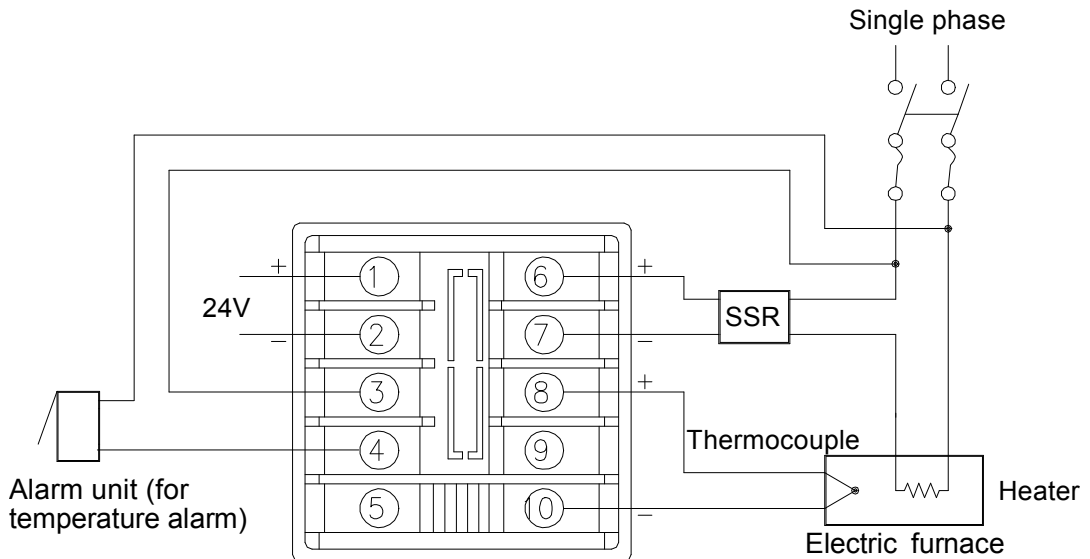

(Fig. 5.2-2)

• For a 24V AC/DC power source, do not confuse polarity when using direct current (DC).

6. Settings

6.1 Operation Flowchart

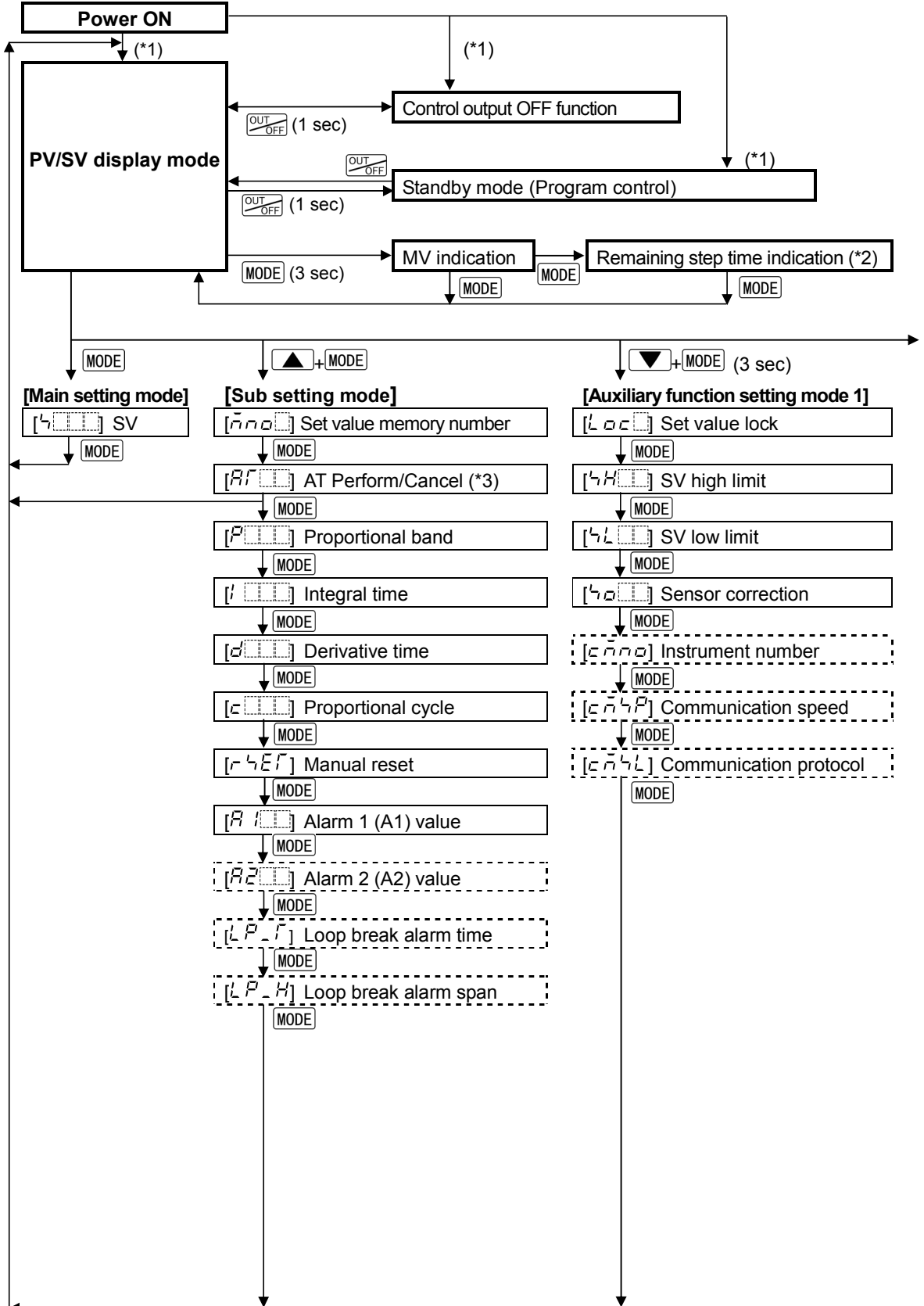

[-----] : Setting items with dotted lines are optional, and they appear only when the options are ordered.

↓ [MODE] : This means that if the [MODE] is pressed, the unit proceeds to the next setting item.

▲+[MODE] : Press the [MODE] key while holding down the ▲ key.

▼+[MODE](3 sec) : Press the [MODE] key for approx. 3 sec while holding down the ▼ key.

▲+▼+[MODE](3 sec) : Press the [MODE] for approx. 3 sec while holding down the ▲, ▼.

▲+▼(3 sec) : Press the ▼ for 3 sec while holding down the ▲ key.

If the [MODE] is pressed for 3 sec, the unit reverts to the PV/SV display mode from any mode.

(*1) Warm-up status lasts 2 sec after power-on, then starts from previous controller status (last shutdown).

(*2) Remaining step time is indicated only during Program control.

(*3) If AT is performed, the unit reverts to the PV/SV display mode.

If AT is cancelled, the unit proceeds to the [Proportional band].

(*4) Select $\square FF \square$ in this mode, and press the [MODE]. The unit reverts to the PV/SV display mode.

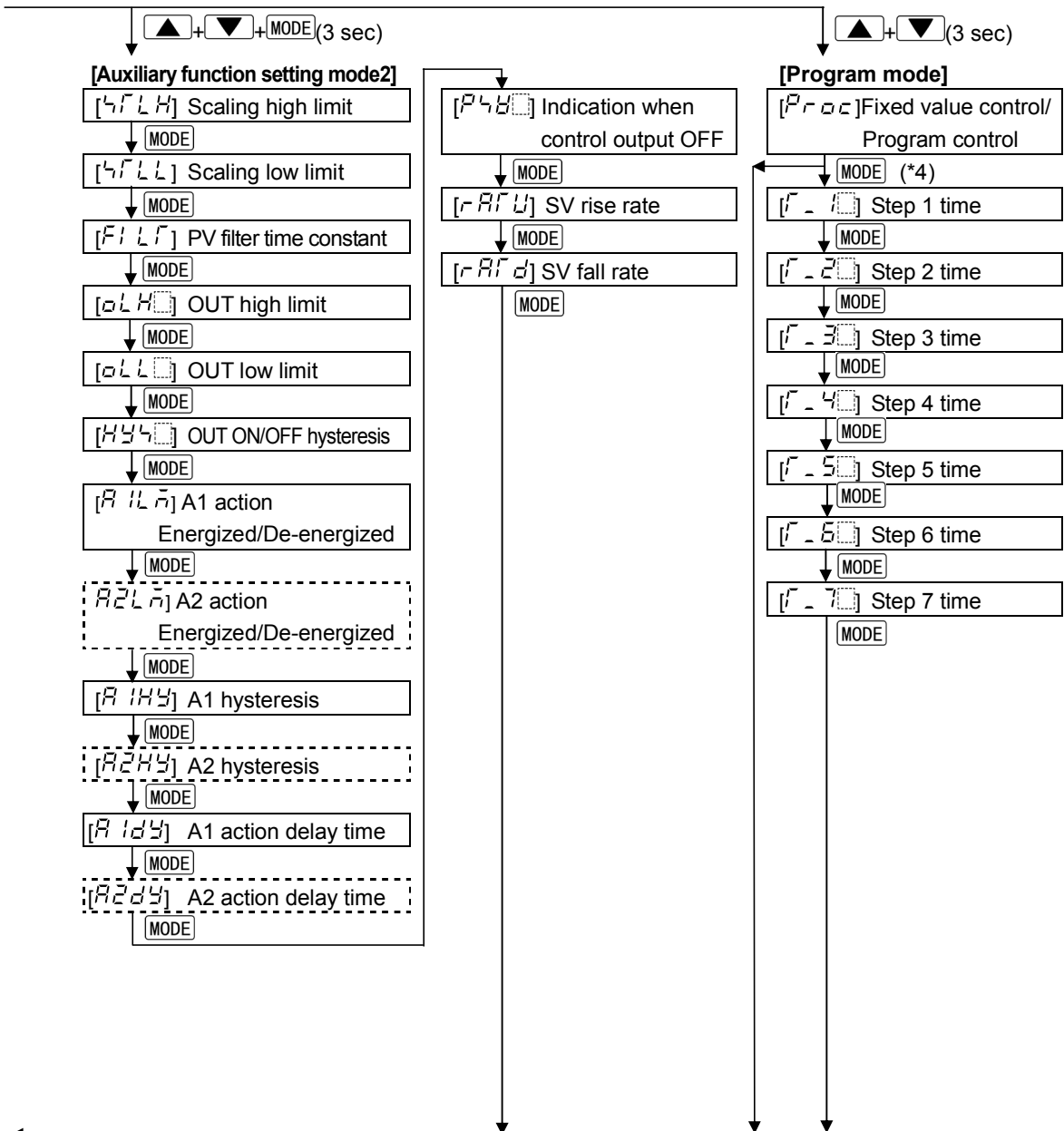

6.2 Settings

The PV display indicates the Sensor characters selected in [Sensor input], and the SV display indicates input range high limit or Scaling high limit value for approx. 2 seconds (warm-up status) after power-on. See (Table 6.2-1).

During this time, all outputs and LED indicators are in OFF status.



Control will then start, indicating PV on the PV display and SV on the SV display.

While control output OFF function is working, the PV display indicates the item selected in [Indication when control output OFF].

(Table 6.2-1)

Input	°C		°F	
	PV display	SV display	PV display	SV display
K	600C	1370	600F	2500
J	400C	1000	400F	1800
R	700C	1760	700F	3200
B	600C	1820	600F	3300
PL-II	PL2C	1390	PL2F	2500
N	700C	1300	700F	2300
S	400C	1760	400F	3200
E	600C	1000	600F	1800
T	700C	4000	700F	7500
C(W/Re5-26)	200C	23 15	200F	4200
Pt100	PT0C	8500	PT0F	9999
JPt100	JPTC	5000	JPTF	9000
Pt100	PT0C	0850	PT0F	1560

Notes before key operation

- Pressing the  key for approx. 1 second from any mode enables the control output OFF function.
Once the control output OFF function is enabled, the function cannot be released even if the power to the instrument is turned OFF and ON again.
To cancel the function, press the  key again for approx. 1 second.
- If the  is pressed for 3 sec, the unit reverts to the PV/SV display mode from any mode.

6.2.1 Main Setting Mode

In the PV/SV display mode, if the  key is pressed, the unit proceeds to the Main setting mode.



The SV can be increased or decreased using the  or  key.

If the  key is pressed, the SV will be registered, and the controller will revert to the PV/SV display mode.

Character	Name, Function, Setting range	Default value
4000	SV • Sets SV (desired value). • Setting range: SV low limit to SV high limit	0°C









6.2.2 Sub Setting Mode

In the PV/SV display mode, if the **MODE** key is pressed while holding down the  key, the unit moves to the Sub setting mode.

The set value can be increased or decreased using the  or  key.

Pressing the **MODE** key registers the set value, and proceeds to the next setting item.

Pressing the **MODE** key at the last setting item registers the set value, and the unit reverts to the PV/SV display mode.

Character	Name, Function, Setting range	Default value
	Set value memory number <ul style="list-style-type: none"> • Selects the number (file) to be set or to be retrieved. • Selection range: 1 to 7 	1
	AT Perform/Cancel <ul style="list-style-type: none"> • Sets AT (Auto-tuning) Perform or Cancel. If the MODE key is pressed after selecting AT Perform, the unit reverts to the PV/SV display mode. • Not available if ON/OFF or PD control is selected in [Control action]. AT (Auto-tuning): <ul style="list-style-type: none"> • If the AT Perform is selected, the AT indicator flashes and the controller reverts to the PV/SV display mode. • After AT is finished, the AT indicator is turned off, and P, I and D values are automatically set. • During AT, none of the settings can be performed. • If the AT is cancelled while processing, P, I, D values revert to the previous values at which AT was performed. • If the  key is pressed during AT, control output OFF function is activated, and pressing the  key again cancels the AT. • AT will be forced to stop if it has not been completed within 4 hours. • Selection item: <ul style="list-style-type: none"> ---- : AT Cancel  : AT Perform 	AT Cancel
	Proportional band <ul style="list-style-type: none"> • Sets the proportional band. • Not available if ON/OFF control is selected in [Control action]. • Setting range: 0.1 to 999.9% 	2.5%
	Integral time <ul style="list-style-type: none"> • Sets the integral time. Setting the value to 0 disables the function (PD control). • Not available if ON/OFF control or PD control is selected in [Control action]. • Setting range: 0 to 3600 seconds 	200 sec
	Derivative time <ul style="list-style-type: none"> • Sets the derivative time. Setting the value to 0 disables the function (PI control). • Not available if ON/OFF control is selected in [Control action]. • Setting range: 0 to 3600 seconds 	50 sec

Character	Name, Function, Setting range	Default value
c	Proportional cycle <ul style="list-style-type: none"> • Sets the proportional cycle. • Not available for Direct current output type or if ON/OFF control is selected in [Control action]. • For the relay contact output type, if the proportional cycle time is decreased, the frequency of the relay action increases, and the life of the relay contact is shortened. • Setting range: 1 to 120 seconds 	R/M: 30 sec S/M: 3 sec
r $4EF$	Manual reset <ul style="list-style-type: none"> • Sets the reset value to correct the offset (deviation between SV and PV in equilibrium status). • Available only when PD control is selected in [Control action]. • Setting range: \pmProportional band converted value [However, in the range of -199.9 to 999.9°C ($^{\circ}\text{F}$)] How to set manual reset: When $SV > PV$, set the positive (+) value ($SV - PV$). When $SV < PV$, set the negative (-) value ($SV - PV$).	0.0°C
R	A1 value <ul style="list-style-type: none"> • Sets the action point of Alarm 1 (A1) output. • Setting the value to 0 or 0.0 disables the function (except Process high and Process low alarm). • Not available if the Rotary switch is set to No.0 or No.7 • Setting range: Refer to (Table 6.2.2-1). 	0°C
$R2$	A2 value <ul style="list-style-type: none"> • Sets the action point of Alarm 2 (A2) output. • Setting the value to 0 or 0.0 disables the function (except Process high and Process low alarm). • Not available if A2 output (option) is not ordered or if Rotary switch is set to No.0 or No.7 in [A2 type] even if it is ordered. • Setting range: Refer to (Table 6.2.2-1). 	0°C
LP_F	Loop break alarm time <ul style="list-style-type: none"> • Sets the time to assess the Loop break alarm. • Available only when Loop break alarm (LA option) is ordered. • Setting range: 0 to 200 minutes 	0 minutes
LP_H	Loop break alarm span <ul style="list-style-type: none"> • Sets the span to assess the Loop break alarm. • Available only when Loop break alarm (LA option) is ordered. • Setting range: Thermocouple, RTD without decimal point: 0 to 150°C Thermocouple, RTD with decimal point: 0.0 to 150.0°C 	0°C

[A1, A2 setting range]

Alarms with the standby function have the same setting range.

(Table 6.2.2-1)

Alarm type	Setting range
High limit alarm	-Input span to Input span °C(°F) *1
Low limit alarm	-Input span to Input span °C(°F) *1
High/Low limits alarm	0 to Input span °C(°F) *1
High/Low limit range alarm	0 to Input span °C(°F) *1
Process high alarm	Input range low limit to Input range high limit *2
Process low alarm	Input range low limit to Input range high limit *2

- For RTD input, the negative low limit value is -199.9.

[Loop break alarm]

The alarm will be activated when the PV does not **rise** as much as the span or more within the time it takes to assess the loop break alarm after the MV has reached 100% or the output high limit value.

The alarm will also be activated when the PV does not **fall** as much value as the span or more within the time it takes to assess loop break alarm after the MV has reached 0% or the output low limit value.

When the control action is Direct (Cooling), read “**fall**” for “**rise**” and vice versa.

6.2.3 Auxiliary Function Setting Mode 1

In the PV/SV display mode, if the **MODE** key is pressed for approx. 3 seconds while holding down the **▼** key, the unit proceeds to Auxiliary function setting mode 1. The set value can be increased or decreased by pressing the **▲** or **▼** key. Pressing the **MODE** key registers the set value and proceeds to the next setting item. Pressing the **MODE** key at the last setting item registers the set value, and the unit reverts to the PV/SV display mode.

Character	Name, Function, Setting range	Default value
Loc□	<p>Set value lock</p> <ul style="list-style-type: none"> Locks the set values to prevent setting errors. The setting item to be locked differs depending on the selection. When selecting Lock, set the necessary items in the status Unlock, then select Lock 1, Lock 2 or Lock 3. Fuzzy self-tuning or AT will not function if [Lc 1□] or [Lc 2□] is selected. Be sure to select Lock 3 when changing the set value frequently via communication function considering the life of non-volatile memory. Selection item: <ul style="list-style-type: none"> ---- (Unlock): All set values can be changed. Lc 1□ (Lock 1): None of the set values can be changed. Lc 2□ (Lock 2): Only SV can be changed. Lc 3□ (Lock 3): All set values can be changed temporarily. However, changed values revert to their previous value after power-off because they are not saved in the non-volatile memory. <p>Since this function has no relation to the memory life, it is well suited when used together with Shinko programmable controllers (with SVTC option).</p> <p>[About Lock 3]</p> <p>When using the FCS-23A as a Fixed value controller</p> <p>The data in the selected Set value memory number can be temporarily changed. However, if the memory number is changed, the data in the previous memory number is cancelled, and returns to the previous values.</p> <p>When using the FCS-23A as a Programmable controller</p> <p>The data in the currently performing step number can be temporarily changed. However, if the step number is changed, the data cancelled, and returns to the previous values.</p> <p>During program standby status, the data changes will be invalidated.</p>	Unlock

Character	Name, Function, Setting range	Default value
4H□□	SV high limit <ul style="list-style-type: none"> • Sets the SV high limit within the Scaling low limit value/Scaling high limit value range. • Setting range: SV low limit to Scaling high limit value 	400°C
4L□□	SV low limit <ul style="list-style-type: none"> • Sets the SV low limit within the Scaling low limit value/Scaling high limit value range. • Setting range: Scaling low limit value to SV high limit 	0°C
40□□	Sensor correction <ul style="list-style-type: none"> • Sets the sensor correction value. • Setting range: -100.0 to 100.0°C (°F) [Sensor correction function] This corrects the input value from the sensor. When a sensor cannot be set at the exact location where control is desired, temperatures measured by the sensor may deviate from the temperature in the controlled location. When controlling with plural controllers, sometimes the measured temperatures (input value) do not concur due to differences in sensor accuracy or dispersion of load capacities. In such a case, the control can be set at the desired temperature by adjusting the input value of sensors. However, it is effective within the input rated range regardless of the sensor correction value. PV after sensor correction= Current PV+ (Sensor correction value)	0.0°C
cñno	Instrument number <ul style="list-style-type: none"> • Sets the instrument number of this unit. (The instrument numbers should be set one by one when multiple instruments are connected in Serial communication, otherwise communication is impossible.) • Available only when the Serial communication (C, C5 option) is ordered. • Setting range: 0 to 95 	0
cñ4P	Communication speed <ul style="list-style-type: none"> • Selects the communication speed of this instrument. (The communication speed of this instrument must be equal to that of the host computer, otherwise communication is impossible.) • Available only when the Serial communication (C, C5 option) is ordered. • Selection item: □□24: 2400bps □□48: 4800bps □□96: 9600bps □ 192: 19200bps 	9600bps
cñ4L	Communication protocol <ul style="list-style-type: none"> • Selects the communication protocol of this instrument. • Available only when the Serial communication (C, C5 option) is ordered. • Selection item: noñL: Shinko protocol ñodP: Modbus ASCII mode 	Shinko protocol

6.2.4 Auxiliary Function Setting Mode 2

In the PV/SV display mode, if the **MODE** key is pressed for approx. 3 seconds while holding down the **▲** and **▼** keys, the unit proceeds to Auxiliary function setting mode 2.

The set value can be increased or decreased using the **▲** or **▼** key.

Pressing the **MODE** key registers the set value, and proceeds to the next setting item.

Pressing the **MODE** key at the last setting item registers the set value, and the unit reverts to the PV/SV display mode.

Character	Name, Function, Setting range	Default value
4FLH	Scaling high limit value <ul style="list-style-type: none"> Sets scaling high limit value. If scaling high limit value is changed, SV high limit automatically changes to the scaling high limit value. Setting range: Scaling low limit to Input range high limit value 	1370°C
4FLl	Scaling low limit value <ul style="list-style-type: none"> Sets scaling low limit value. If scaling low limit value is changed, SV low limit automatically changes to the scaling low limit value. Setting range: Input range low limit to scaling high limit value 	-200°C
FILF	PV filter time constant <ul style="list-style-type: none"> Sets PV filter time constant. However, if the set value is set too large, it affects control result due to the delay of response. Setting range: 0.0 to 10.0 sec 	0.0 sec
oLH□	OUT high limit value <ul style="list-style-type: none"> Sets the OUT (control output) high limit value. Not available if ON/OFF control is selected in [Control action] Setting range: OUT low limit value to 100% (Direct current output: OUT low limit value to 105%) 	100%
oLl□	OUT low limit value <ul style="list-style-type: none"> Sets the OUT (control output) low limit value. Not available if ON/OFF control is selected in [Control action] Setting range: 0% to OUT high limit value (Direct current output: -5% to OUT high limit value) 	0%
H44□	OUT ON/OFF hysteresis <ul style="list-style-type: none"> Sets OUT (control output) ON/OFF hysteresis. Available only when ON/OFF control is selected in [Control action] Setting range: 0.1 to 100.0°C(°F) 	1.0°C

Character	Name, Function, Setting range	Default value
<i>R1L\bar{n}</i>	A1 action Energized/De-energized <ul style="list-style-type: none"> • Selects A1 action Energized/De-energized. • Not available if Rotary switch is set to No.0 or No.7 in [A1 type] • Selection item: <input type="checkbox"/>no\bar{n}: Energized, <input type="checkbox"/>rE\bar{B}: De-energized 	Energized
<i>R2L\bar{n}</i>	A2 action Energized/De-energized <ul style="list-style-type: none"> • Selects A2 action Energized/De-energized. • Not available if A2 option is not ordered or if Rotary switch is set to No.0 or No.7 in [A2 type]. • Selection item: <input type="checkbox"/>no\bar{n}: Energized, <input type="checkbox"/>rE\bar{B}: De-energized 	Energized
<i>R1HY</i>	A1 hysteresis <ul style="list-style-type: none"> • Sets A1 hysteresis. • Not available if the Rotary switch is set to No.0 or No.7 in [A1 type] • Setting range: 0.1 to 100.0°C 	1.0°C
<i>R2HY</i>	A2 hysteresis <ul style="list-style-type: none"> • Sets A2 hysteresis. • Not available if A2 option is not ordered, or if the Rotary switch is set to No.0 or No.7 in [A2 type] even if the A2 option is ordered. • Setting range: 0.1 to 100.0°C 	1.0°C
<i>R1dY</i>	A1 action delay time <ul style="list-style-type: none"> • Sets A1 action delay time. When setting time has elapsed after the input enters the alarm output range, the alarm is activated. • Not available if the Rotary switch is set to No.0 or No.7 in [A1 type]. • Setting range: 0 to 9999 seconds 	0 sec
<i>R2dY</i>	A2 action delay time <ul style="list-style-type: none"> • Sets A2 action delay time. When setting time has elapsed after the input enters the alarm output range, the alarm is activated. • Not available if A2 option is not ordered or if the Rotary switch is set to No.0 or No.7 in [A2 type] even if A2 option is ordered. • Setting range: 0 to 9999 seconds 	0 sec
<i>P4\square</i>	Indication when control output OFF <ul style="list-style-type: none"> • Selects the indication when the control output is off. • Selection item: <input type="checkbox"/>oFF\square: OFF is indicated on the PV display. R\squareoFF: No indication (all unlit) P$\bar{B}$$\square$: Only PV is indicated. 	OFF is indicated on the PV display.

Character	Name, Function, Setting range	Default value
rAFU	SV rise rate <ul style="list-style-type: none"> • Sets the SV rise rate (Rising value per minute). Setting the value to 0 or 0.0 disables the function. • Setting range: 0 to 9999°C/min. With a decimal point: 0.0 to 999.9°C/min. 	0°C/minute
rAFd	SV fall rate <ul style="list-style-type: none"> • Sets the SV fall rate (Falling value per minute). Setting the value to 0 or 0.0 disables the function. • Setting range: 0 to 9999°C/min. With a decimal point: 0.0 to 999.9°C/min. 	0°C/minute

Alarm 1 (A1), 2 (A2) Energized/De-energized function

[If the alarm action Energized is selected]

When the alarm output indicator is lit, the alarm output (terminals 7-8, 9-10) is conducted (ON). When the alarm output indicator is unlit, the alarm output is not conducted (OFF).

[If the alarm action De-energized is selected]

When the alarm output indicator is lit, the alarm output (terminals 7-8, 9-10) is not conducted (OFF). When the alarm output indicator is unlit, the alarm output is conducted (ON).

High limit alarm (when Energized is set) High limit alarm (when De-energized is set)

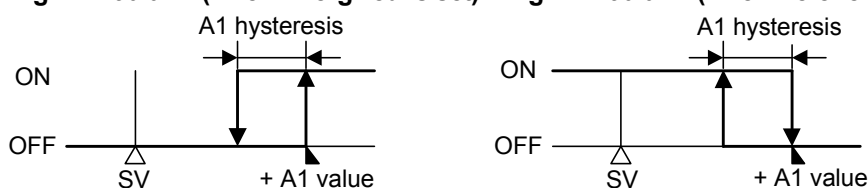





A1: Alarm 1

For Alarm 2(A2), read "A2" for "A1".

(Fig. 6.2.4-1)

6.2.5 Program Mode

In PV/SV display mode, if the  key is pressed for approximately 3 seconds while holding down the  key, the units moves to the Program mode.



The  or  key increases or decreases the set values (numeric value).

Pressing the  key registers the set value, and proceeds to the next setting item.

If the  key is pressed at the last setting item, the set value is registered and the unit reverts to the PV/SV display mode.

- Data in Set value memory numbers (1 to 7, set in Fixed value control) is assigned to Steps 1 to 7 respectively.

For example, data in Set value memory number 1 becomes Step 1 data, and data in Set value memory number 2 becomes Step 2 data, and so on.



- If the Pattern end output is selected and the Program control is performed, the Pattern end output is turned on when the program is completed.
- If the  key is pressed while the Pattern end output is on, the Pattern end output will be turned off. If the  key is pressed again, the program will be performed.

- The following shows the program pattern example.
Set the step time to 00.00 for the unnecessary steps.

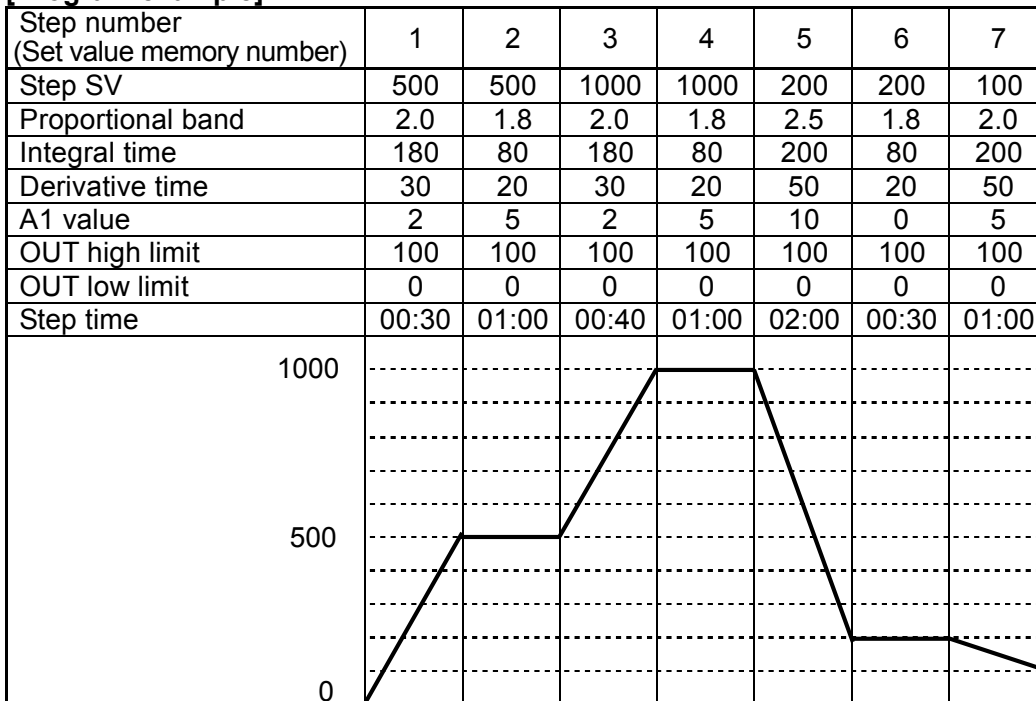
[Program example]







Character	Name, Function, Setting range	Default value
<i>P r o c</i>	Fixed value control/Program control switching <ul style="list-style-type: none"> Fixed value control or Program control can be selected. If the [MODE] key is pressed after selecting the fixed value control, the controller will revert to the PV/SV display mode. If the [MODE] key is pressed after selecting Program control, step time from Step 1 to Step 7 can be set. Selection item: <i>o F F</i>: Fixed value control <i>P r o c</i>: Program control 	Fixed value control
<i>r _ 1</i>	Step 1 time <ul style="list-style-type: none"> Sets Step 1 time. (Available only for Program control) (e.g.) When setting 1 hour 58 minutes, set as <i>[0 1 5 8]</i>. Setting range: 00.00 to 99.59 	00.00
<i>r _ 2</i>	Step 2 time <ul style="list-style-type: none"> Sets Step 2 time. (Available only for Program control) Setting range: 00.00 to 99.59 	00.00
<i>r _ 3</i>	Step 3 time <ul style="list-style-type: none"> Sets Step 3 time. (Available only for Program control) Setting range: 00.00 to 99.59 	00.00
<i>r _ 4</i>	Step 4 time <ul style="list-style-type: none"> Sets Step 4 time. (Available only for Program control) Setting range: 00.00 to 99.59 	00.00
<i>r _ 5</i>	Step 5 time <ul style="list-style-type: none"> Sets Step 5 time. (Available only for Program control) Setting range: 00.00 to 99.59 	00.00

Character	Name, Function, Setting range	Default value
	Step 6 time <ul style="list-style-type: none"> • Sets Step 6 time. (Available only for Program control) • Setting range: 00.00 to 99.59 	00.00
	Step 7 time <ul style="list-style-type: none"> • Sets Step 7 time. (Available only for Program control) • Setting range: 00.00 to 99.59 	00.00

6.2.6 Control Output OFF Function

Control output OFF function [

- The control action and output of an instrument (or instruments) can be turned off without turning off their power supplies using this function.
- Pressing the  key for approx. 1 second from any mode enables the control output OFF function. The PV display indicates the setting item selected in [Indication when control output OFF].
To cancel the function, press the  key again for approx. 1 second.
- Once the control output OFF function is enabled, the function cannot be released even if the power to the instrument is turned OFF and ON again.
To cancel the function, press the  key again for approx. 1 second.
- During Program control, the  key becomes the Program Start/Stop key, and the control output OFF function is disabled.

6.2.7 MV, Remaining Step Time Indication

MV indication

In the PV/SV display mode, press the  key for approx. 3 seconds.

Keep pressing the  key until the MV appears, though the SV setting mode appears while processing.

The MV indicator lights. The SV display indicates MV. The 2nd dot from the right on the SV display flashes.

For the fixed value control, when the  key is pressed again, the unit reverts to the PV/SV display.

Remaining step time indication

For Program control, if the  key is pressed while in MV indication, remaining step time will be indicated on the SV display. The TIME indicator lights.

By pressing the  key again, the unit reverts to the PV/SV display mode.

7. Set Value Memory Function (SM Option)

If the SM option is ordered, 2 files (8 pieces of data per file) of data can be memorized by external operation.

Control can be performed by selecting the desired file.

One file contains the following data:

SV, PID, A1 value, A2 value, OUT high limit, OUT low limit

The SM option cannot be ordered in combination with A2, LA or C/C5 option.

- Wiring example of Set value memory number external selection

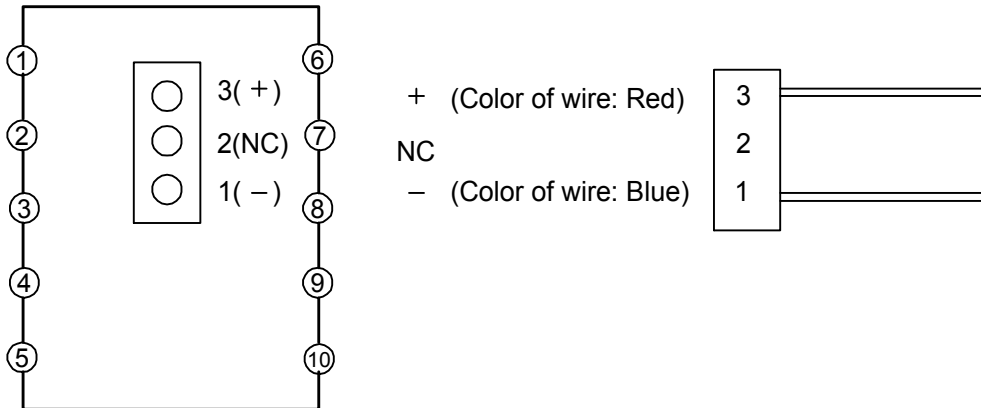

Contact input:

Set value memory number 2 can be selected by connecting terminals 1 and 3.

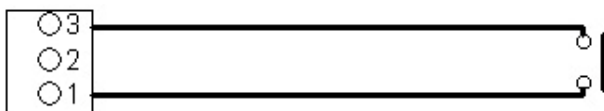

Open collector input:

When selecting Set value memory number 2 by the Open collector, connect No.1 pin to the collector and No. 3 pin to the emitter.

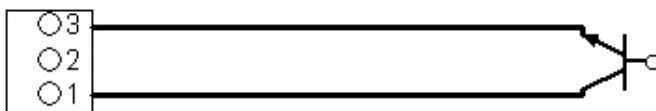

- If Set value memory number 2 is selected by external operation, it is impossible to select Set value memory number by front key operation.
- The memory number cannot be changed during setting mode or AT (auto-tuning).

8. Operation

After the controller is mounted to the control panel and wiring is completed, operate the unit following the procedures below.

8.1 When Using the FCS-23A as a Temperature Controller

(1) Turn the power supply to the FCS-23A ON.

For approx. 2 seconds after power-on, the sensor type and the temperature unit selected in [Sensor input] will be indicated on the PV display, and input range high limit value will be indicated on the SV display.

See (Table 8.1-1).

During this time, all outputs and LED indicators are in OFF status.

After that, control starts, indicating PV on the PV display and SV on the SV display.

When the Control output OFF function is working, the item selected in [Indication when control output OFF] mode is indicated on the PV display.

(Table 8.1-1)

Input	°C		°F	
	PV display	SV display	PV display	SV display
K	600C	1370	600F	2500
J	400C	1000	400F	1800
R	700C	1760	700F	3200
B	600C	1820	600F	3300
PL-II	PL2C	1390	PL2F	2500
N	700C	1300	700F	2300
S	400C	1760	400F	3200
E	600C	1000	600F	1800
T	700C	4000	700F	7500
C(W/Re5-26)	600C	2315	600F	4200
Pt100	PT0C	8500	PT0F	9999
JPt100	JPTC	5000	JPTF	9000
Pt100	PT0C	0850	PT0F	1560

(2) Input each set value.

Refer to Section "6. Settings".

When controlling by Fuzzy self-tuning PID, select "Perform" in [AT Perform/Cancel] to start control in optimal conditions.

(3) Turn the load circuit power ON.

Control starts, so as to reach, and then maintain the control target at the SV.

8.2 When Using the FCS-23A as a Simplified Programmable Controller

(1) Turn the power supply to the FCS-23A ON.

For approx. 2 seconds after power-on, the sensor type and the temperature unit selected in [Sensor input] are indicated on the PV display, and input range high limit value is indicated on the SV display.

See (Table 8.1-1).

During this time, all outputs and LED indicators are in OFF status.

After that, the unit enters the PV/SV display mode.

When the Control output OFF function is working, the setting item selected in [indication when control output OFF] is indicated on the PV display.

(2) Input each set value and step time

Refer to Section "6. Settings".

The PV display indicates the PV, and the unit enters standby mode.

(3) Turn the load circuit power ON.

(4) Program control start

If "Automatic start" is selected in [Program start Auto/Manual], the unit will switch to warm-up status for approx. 2 seconds after power-on, then Program control automatically starts from Step 1.

If "Manual start" is selected in [Program start Auto/Manual], the unit will switch to warm-up status for approx. 2 seconds after power-on. The unit proceeds to standby status. In this status, if the  key is pressed, Program control starts from Step 1.



For Program control start, SV start (0°C) is used.

During Program control (RUN), the Step number (Set value memory number) can be changed, however it is not effective.

To terminate Program control while processing

Program control will be terminated if the  key is pressed for approx. 1 sec or longer.

To switch the indication of MV and Remaining step time

In the PV/SV display, if the  key is pressed for approximately 3 seconds, the MV is indicated. If the  key is pressed again, the remaining step time will be indicated.

Instrument status when power is restored

After restoration following a power failure during Program control, the FCS-23A resumes performance from the point at which power was lost.

The PV display flashes until the step at which the power failure occurred is finished.

9. Action Explanations

9.1 Standard Control Action

Action		Heating (reverse) action			Cooling (direct) action		
Control action							
Output	Relay contact						
	Non-contact voltage	+⑥ 12V DC -⑦	+⑥ 12/0V DC -⑦ (*1)	+⑥ 0V DC -⑦	+⑥ 0V DC -⑦	+⑥ 0/12V DC -⑦ (*1)	+⑥ 12V DC -⑦
	Direct current	+⑥ 20mA DC -⑦	+⑥ 20 to 4mA DC -⑦ (*2)	+⑥ 4mA DC -⑦	+⑥ 4mA DC -⑦	+⑥ 4 to 20mA DC -⑦ (*2)	+⑥ 20mA DC -⑦
Indicator [OUT] Green							

(*1) Cycle action is performed according to deviation.

(*2) Changes continuously according to deviation.

: Turns ON (lit) or OFF (unlit).

9.2 ON/OFF Control Action

Action		Heating (reverse) action		Cooling (direct) action	
Control action					
Output	Relay contact				
	Non-contact voltage	+ ⑥ 12V DC - ⑦	+ ⑥ 0V DC - ⑦	+ ⑥ 0V DC - ⑦	+ ⑥ 12V DC - ⑦
	Direct current	+ ⑥ 20mA DC - ⑦	+ ⑥ 4mA DC - ⑦	+ ⑥ 4mA DC - ⑦	+ ⑥ 20mA DC - ⑦
Indicator [OUT] Green					

: Turns ON or OFF.

9.3 Pattern End Action

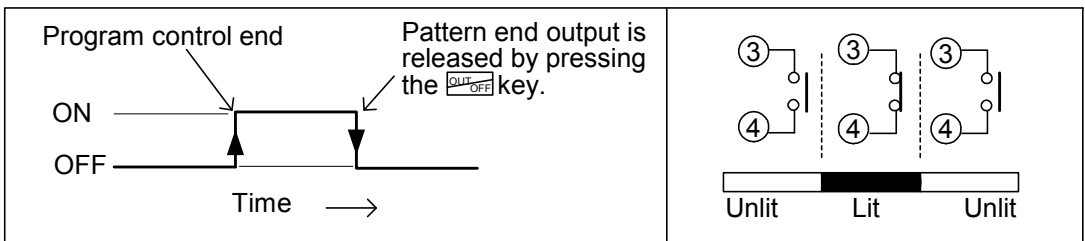

Pattern end output is turned ON when the Program control is completed, and it is released when the key is pressed.

Use terminals 3 and 5 for Pattern end 2 output.

The A2 indicator lights when Pattern end 2 output is ON.

9.4 Alarm 1 (A1), Alarm 2 (A2) Action

	High limit alarm	Low limit alarm
Alarm action		
Alarm output	+side -side	+side -side
	High/Low limits alarm	High/Low limit range alarm
Alarm action		
Alarm output		
	Process high alarm	Process low alarm
Alarm action		
Alarm output		
	High limit alarm with standby	Low limit alarm with standby
Alarm action		
Alarm output	+side -side	+side -side

	High/Low limits alarm with standby	High/Low limit range alarm with standby
Alarm action		
Alarm output		
	Process high alarm with standby	Process low alarm with standby
Alarm action		
Alarm output		

- : A1 output terminals 3 and 4 are closed.
- : A1 output terminals 3 and 4 are closed or opened.
- : A1 output terminals 3 and 4 are opened.
- : Standby functions.

A2 output terminals: 3 and 5

A1 and A2 indicators light when their output terminals are closed, and go off when their output terminals are opened.

For A2, read "A2" for "A1".

10. Control Actions

10.1 Fuzzy Self-tuning

Fuzzy self-tuning is a function that performs fine adjustment of PID values automatically. Stable control can be carried out even if the conditions of the production process are changed due to various external factors (types and rates of production).

- (1) When using the controller for the first time, perform the AT (auto-tuning) or set the proper PID values by keypad operation.
- (2) When control initiates, the controller performs this function by the previously adjusted PID values.
- (3) When the control result is disordered by disturbance or a change in the process, the controller checks the convergence status, and performs a fine adjustment of PID values if necessary.

The instrument is constantly in self-tuning status, and when deviation occurs, the tuning starts.

- If the convergence is performed smoothly, the PID values are not changed.
- If the convergent speed is slow, the controller corrects the PID values to accelerate the convergence.
- When overshoot is generated during the convergence, the controller changes the PID values to correct this.
- When hunting occurs, the controller checks its waveform and performs a fine adjustment of PID values.

Even in Fuzzy self-tuning status, when very large hunting occurs and the control is not stabilized, AT automatically starts.

When the AT "Perform" is selected by the keypad, AT initiates, and when the control is stabilized, the AT is released and the controller returns to self-tuning status.

When lock mode [L C □] or [L C □] is selected, Fuzzy self-tuning or AT does not work.
With a control system in which load fluctuation periodically occurs, the Fuzzy self-tuning PID control may malfunction.
In such a case, use the controller with the PID control.

10.2 PID

(1) Proportional band (P)

Proportional action is the action which the control output varies in proportion to the deviation between the SV (desired value) and the processing temperature (PV).

If the proportional band is narrowed, even if the output changes by a slight variation of the processing temperature, better control results can be obtained as the offset decreases.

However, if the proportional band is narrowed too much, even slight disturbances may cause variation in the processing temperature, and control action changes to ON/OFF control action and the so-called hunting phenomenon occurs. Therefore, when the processing temperature comes to the balanced position near the SV and a constant temperature is maintained, the most suitable value is selected by gradually narrowing the proportional band while observing the control results.

(2) Integral time (I)

Integral action is used to eliminate offset. When the integral time is shortened, the returning speed to the setting point is accelerated. However, the cycle of oscillation is also accelerated and control becomes unstable.

(3) Derivative time (D)

Derivative action is used to restore the change in the processing temperature according to the rate-of-change. It reduces the amplitude of overshoot and undershoot width.

If the derivative time is shortened, the restoring value becomes small, and if the derivative time is extended, an excessive returning phenomenon may occur and the control system may oscillate.

10.3 AT of This Controller

In order to set each value of P, I and D automatically, AT process should be made to fluctuate to obtain an optimal value.

Sometimes the AT process will not fluctuate if AT is performed at or near room temperature. Therefore AT might not finish normally.

- (A) If there is a large difference between the SV and PV as the temperature is rising**
 The AT process will fluctuate at the temperature 1.5% of input span lower than the SV.

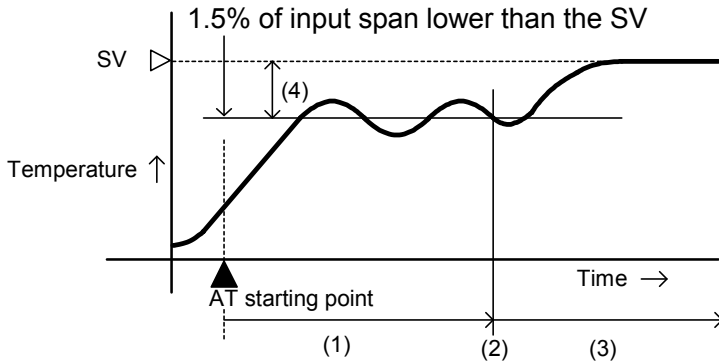

- (1) Calculating PID constant
- (2) PID constant calculated
- (3) Controlled by the PID constant set by AT.
- (4) 1.5% of input span

(Fig. 10.3-1)

- (B) When the control is stable or when PV is within $SV \pm 1.5\%$ of input span.**
 The AT process will fluctuate around the SV.

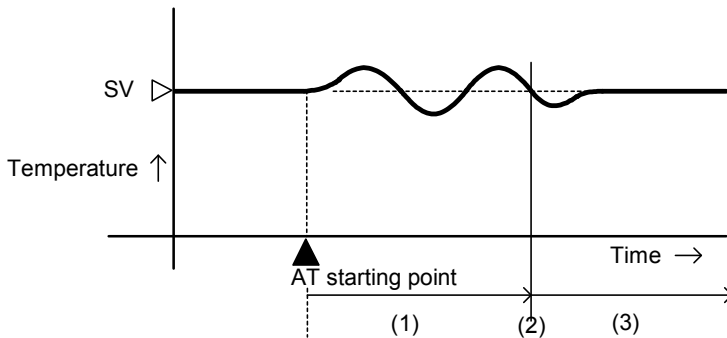

- (1) Calculating PID constant
- (2) PID constant calculated
- (3) Controlled by the PID constant set by AT.

(Fig. 10.3-2)

- (C) When the PV is 1.5% of input span higher than the SV**
 The AT process will fluctuate at the temperature 1.5% of input span higher than the SV.

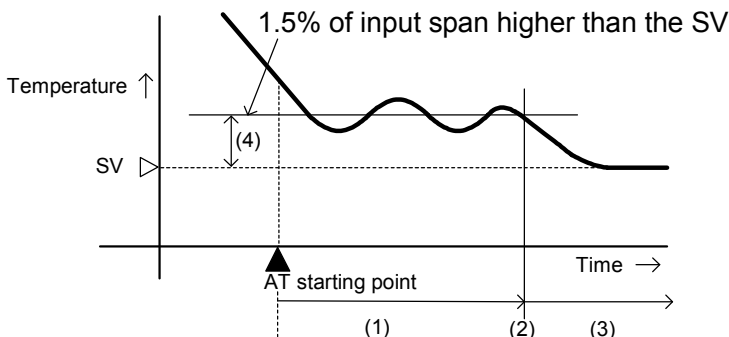

- (1) Calculating PID constant
- (2) PID constant calculated
- (3) Controlled by the PID constant set by AT.
- (4) 1.5% of input span

(Fig. 10.3-3)

11. Specifications

11.1 Standard Specifications

Mounting:	Flush
Setting:	Input system using membrane sheet key
Display	
PV display:	Red LED, 4 digits, character size, 8(H) x 4(W)mm
SV display:	Green LED, 4 digits, character size, 8(H) x 4(W)mm
Accuracy (Indication, setting)	
Thermocouple:	Within $\pm 0.3\%$ of each input span ± 1 digit K, J, T inputs, range less than 0°C (32°F): Within $\pm 0.5\%$ of each input span ± 1 digit R, S inputs, range 0 to 200°C (0 to 400°F): Within $\pm 6^{\circ}\text{C}$ (12°F) B input, range 0 to 300°C (0 to 600°F): Accuracy is not guaranteed. (Cold junction compensation accuracy: $\pm 1^{\circ}\text{C}$, at 0 to 50°C)
RTD:	Within $\pm 0.3\%$ of each input span ± 1 digit
Input sampling period:	125ms
Input	
Thermocouple:	K, J, R, S, B, E, T, N, PL-II, C (W/Re5-26) External resistance, 100Ω or less When input is burnt out, Overscale
RTD:	Pt100, JPt100, 3-wire system Allowable input lead wire resistance: 10Ω or less per wire When input is burnt out, Overscale
OUT (Control output)	
Relay contact:	1a Control capacity: 3A 250V AC (resistive load) 1A 250V AC (inductive load $\cos\phi=0.4$) Electrical life: 100,000 cycles
Non-contact voltage:	For SSR drive 12^+2_0V DC maximum 40mA DC (short circuit protected)
Direct current:	4 to 20mA DC (Isolated type) Load resistance, maximum 550Ω

Alarm 1 output

The alarm action point is set by the \pm deviation from the SV (except Process alarm).
[When A1 action Energized is selected]

When the input goes outside the range, the output turns ON or OFF (in the case of High/Low limit range alarm).

[When A1 action De-energized is selected]

The output acts conversely.

An alarm can be selected by Rotary switch and DIP switch from 13 types of alarm (including No alarm action) plus Pattern end output: High limit alarm, Low limit alarm, High/Low limits alarm, High/Low limit range alarm, Process high alarm and Process low alarm, the standby function which is applied to them respectively, as well as Pattern end output.

Setting accuracy: Within $\pm 0.3\%$ of each input span ± 1 digit

Action: ON/OFF action

Hysteresis: 0.1 to 100.0°C ($^{\circ}\text{F}$)

Output: Relay contact 1a

 Control capacity: 3A 250V AC (resistive load)

 1A 250V AC (inductive load $\cos\phi=0.4$)

 (However, A1, A2 common terminal, Max. 3A)

 Electrical life: 100,000 cycles

Controlling action

The fuzzy self-tuning PID, PID, PD or ON/OFF control is selectable by DIP switch.

Fuzzy self-tuning PID control

Proportional band (P): Automatic
 Integral time (I): Automatic
 Derivative time (D): Automatic
 Anti-reset windup (ARW): Automatic
 Proportional cycle: 1 to 120 sec
 Output high/low limit: 0 to 100% (Direct current output: -5 to 105%)

PID control (with AT function)

Proportional band (P): 0.1 to 999.9%
 Integral time (I): 0 to 3600 sec (off when set to 0)
 Derivative time (D): 0 to 3600 sec (off when set to 0)
 Anti-reset windup (ARW): Automatic
 Proportional cycle: 1 to 120 sec
 Output high/low limit: 0 to 100% (Direct current output, -5 to 105%)

PD control

Proportional band (P): 0.1 to 999.9%
 Derivative time (D): 0 to 3600 sec (off when set to 0)
 Proportional cycle: 1 to 120 sec
 Reset: \pm Proportional band converted value
 Within a range of -199.9 to 999.9°C (°F)
 Output high/low limit: 0 to 100% (Direct current output: -5 to 105%)

ON/OFF control

Hysteresis: 0.1 to 100.0°C (°F)

Supply voltage: 100 to 240V AC, 50/60Hz, 24V AC/DC, 50/60Hz

Allowable voltage fluctuation: 100 to 240V AC: 85 to 264V AC
 24V AC/DC: 20 to 28V AC/DC

Ambient temperature: 0 to 50°C (32 to 122°F)

Ambient humidity: 35 to 85%RH (non-condensing)

Power consumption: Approx. 8VA

Circuit insulation configuration

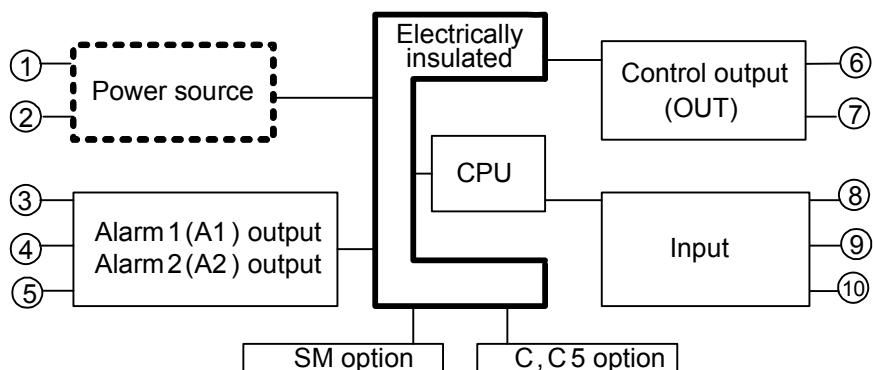

When control output (OUT) is Direct current output type or Non-contact voltage output type (the SSR drive), Input is not electrically insulated from Control output (OUT).

Insulation resistance

10MΩ or more, at 500V DC

Dielectric strength

Between input terminal and power terminal, 1.5kV AC for 1 minute

Between output terminal and power terminal, 1.5kV AC for 1 minute

Weight: Approx. 140g**External dimensions:** 48 x 48 x 100mm (W x H x D)**Material:** Base, Case: Flame-resistant resin**Color:** Base, Case: Light gray

Attached functions: Power failure countermeasure
 Self-diagnosis
 Automatic cold junction temperature compensation
 Burnout

[Burnout]

When the thermocouple or RTD input is burnt out, OUT is turned off (for Direct current output type, OUT low limit value), and the PV display flashes " _ _ _ _ ".

[Input error indication]

Indication	Contents	OUT1
" _ _ _ _ " flashes.	Overscale Measured value has exceeded Indication range high limit value.	OFF (4mA) or OUT low limit value
" _ _ _ _ " flashes.	Underscale Measured value has dropped below Indication range low limit value.	OFF (4mA) or OUT low limit value

TC, RTD inputs

Input	Input range	Indication range	Control range
T	-199.9 to 400.0°C	-199.9 to 405.0°C	-205.0 to 405.0°C
	-199.9 to 750.0°F	-199.9 to 759.0°F	-209.0 to 759.0°F
Pt100	-199.9 to 850.0°C	-199.9 to 860.0°C	-210.0 to 860.0°C
	-200 to 850°C	-210 to 860°C	-210 to 860°C
	-199.9 to 999.9°F	-199.9 to 999.9°F	-211.0 to 1010.9°F
	-320 to 1560°F	-338 to 1578°F	-338 to 1578°F
JPt100	-199.9 to 500.0°C	-199.9 to 506.0°C	-206.0 to 506.0°C
	-199.9 to 900.0°F	-199.9 to 910.9°F	-211.0 to 910.9°F

Indication range and Control range for thermocouple inputs other than the above:
 [Input range low limit value – Input span x 1%] to [Input range high limit value + Input span x 1%]

[Self-diagnosis]

The CPU is monitored by a watchdog timer, and when an abnormal status is found on the CPU, the controller is switched to warm-up status.

[Automatic cold junction temperature compensation] (Thermocouple input type)

This detects the temperature at the connecting terminal between the thermocouple and the instrument, and always maintains it at the same status as if the reference junction location temperature was at 0°C (32°F).

[Power failure countermeasure]

The setting data is backed up in the non-volatile IC memory.

[Warm-up indication]

For approximately 2 seconds after power-on, the input type and the temperature unit are indicated on the PV display, and the input range high limit value is indicated on the SV display.

[SV ramp function]

When the SV is adjusted, it approaches the new SV by the preset rate-of-change. (Rising/Falling value per minute)

When the power is turned on, the control starts from the PV, and approaches the SV by the rate-of-change.

For Program control, this function will not work.

Setting range:

SV rise rate: 0 to 9999°C/min (°F/min); Thermocouple inputs except T
0.0 to 999.9°C/min (°F/min); T, RTD inputs

SV fall rate: 0 to 9999°C/min (°F/min); Thermocouple inputs except T
0.0 to 999.9°C/min (°F/min); T, RTD inputs

(Default value of the SV rise and fall rate: 0°C/min. However, setting to 0 disables the function.)

Accessories:

One-touch type mounting brackets: 1 set

Instruction manual: 1 copy

Unit label: 1 label

Wire harness CO: 1 length (When the C option is ordered.)

Wire harness CO }
Wire harness C5 } 1 length each (When the C5 option is ordered.)

Wire harness E: 1 length (When the SM option is ordered.)

Screw type mounting brackets: 1 set (When the BL option is ordered.)

Terminal cover: 1 piece (When the TC option is ordered.)

11.2 Optional Specifications

Alarm 2 (Option code: A2)

The alarm action point is set by the \pm deviation from the SV (except Process alarm).

[When A2 action Energized is selected]

When the input goes outside the range, the output turns ON or OFF (in the case of High/Low limit range alarm).

[When A2 action De-energized is selected]

The output acts conversely.

An alarm can be selected by Rotary switch and DIP switch from 13 types of alarm (including No alarm action) and Pattern end output: High limit alarm, Low limit alarm, High/Low limits alarm, High/Low limit range alarm, Process high alarm and Process low alarm, the standby function which is applied to them respectively, as well as Pattern end output.

When Alarm 2 (A2 option) and Loop break alarm (LA option) are ordered together, they utilize common output terminals.

Setting accuracy: The same as Indication accuracy

Action: ON/OFF action

Hysteresis: 0.1 to 100.0°C (°F)

Output: Relay contact, 1a

Control capacity: 3A 250V AC (resistive load)

1A 250V AC (inductive load $\cos\phi=0.4$)

(However, A1 and A2 common terminal, Max. 3A)

Electrical life: 100,000 cycles

Loop break alarm (Option code: LA)

Detects the breaking status on the loop such as heater burnout, sensor burnout or actuator trouble.

When this option and Alarm 2 (A2) option are ordered together, they utilize common output terminals.

Setting range: Loop break alarm time: 0 to 200 minutes

Loop break alarm span: 0 to 150°C(°F), 0.0 to 150.0°C(°F)

Output: Relay contact 1a

Control capacity: 3A 250V AC (resistive load)

1A 250V AC (inductive load, $\cos\phi=0.4$)

Electrical life: 100,000 cycles

Serial communication (Option code: C5, C)

The following operations can be executed from an external computer.

(1) Reading and setting of the SV, PID values and various set values

(2) Reading of the PV and the action status

(3) Function change

Communication line: EIA RS-485 (C5 option)

EIA RS-232C (C option)

Communication method: Half-duplex communication

Synchronization method: Start-stop synchronization

Communication speed: 2400, 4800, 9600, 19200bps (Selectable by keypad)

Data format Start bit: 1

Data bit: 7

Parity: Even parity

Stop bit: 1

Communication protocol: Shinko protocol, Modbus ASCII (Selectable by keypad)
(When Modbus protocol is selected, the Digital external setting is not usable.)

Digital external setting: Receives digital set value from Shinko Programmable controllers PC-900, PCD-33A (with SVTC option).
Set the Set value lock of the FCS-23A to "Lock 3".

Set value memory number external selection (Option code: SM)

Selects the set value memory number from 2 files by external terminals:

Each file contains the following data:

SV, PID values, A1 value, A2 value, OUT high limit value, OUT low limit value

Memory number: 1, 2 (2 files)

Data: 8

The options (A2, LA, C/C5) cannot be ordered in combination with this option.

Color black (Option code: BK)

Front panel: Dark gray

Case: Black

Terminal cover (Option code: TC)

Electrical shock protection terminal cover

Screw-type mounting brackets (Option code: BL)

Mountable panel thickness: 1 to 8mm

Drip-proof/Dust-proof (IP54) (Option code: IP)

Drip-proof and Dust-proof specification IP54

Effective only for front panel surface, case section is excluded.

Mount the controller vertically to the flat, rigid panel to ensure it adheres to the

Drip-proof/Dust-proof specification.

The front cover (soft type, FC-48-S, sold separately) is recommended for comprehensive Drip-proof/Dust-proof protection.

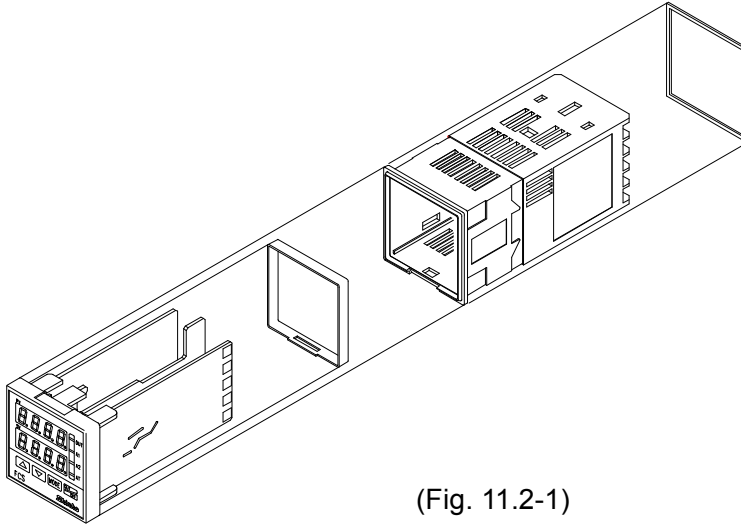

(Fig. 11.2-1)

User specified

- Input, Scale range: Shipped with specified input and range.
- Alarm type: Shipped with specified alarm type (A1, A2).
- Control action: Shipped with specified control action. (e.g. PD control).

12. Troubleshooting

If any malfunctions occur, refer to the following items after checking the power and the wiring.

 **Warning**





Turn the power supply to the instrument off before wiring or checking.
Working on or touching the terminal with the power switched on may result in severe injury or death due to electric shock.

<Indication>





Problem	Possible cause and solution
The PV display is indicating [FF], no indication or only PV.	<ul style="list-style-type: none"> • Control output OFF function is working. To release the function, press the  key for approx. 1 sec.
The PV display is flashing [- - -].	<ul style="list-style-type: none"> • Thermocouple or RTD is burnt out. Change each sensor. [Thermocouple] If the input terminals of the instrument are shorted, and if a value around room temperature is indicated, the instrument is likely to be operating normally, however, the sensor may be burnt out.

Problem	Possible cause and solution
The PV display is flashing [_ _ _ _].	<p>[RTD]</p> <p>If approximate 100Ω of resistance is connected to the input terminals between A-B of the instrument and between B-B is shorted, and if a value around 0°C (32°F) is indicated, the instrument is likely to be operating normally, however, the sensor may be burnt out.</p> <ul style="list-style-type: none"> • Check whether the lead wire of thermocouple or RTD is securely mounted to the instrument input terminals.
The PV display is flashing [- - - -].	<ul style="list-style-type: none"> • Check if polarity of thermocouple or compensating lead wire is correct. • Check whether codes (A, B, B) of RTD match with the instrument terminals.
The indication of the PV display is irregular or unstable.	<ul style="list-style-type: none"> • Selection of the sensor input is improper. Set the sensor input properly using Rotary switch (SW303) and the DIP switch (SW304). • Temperature unit (°C or °F) is not correct. Set it to a proper unit with the DIP switch (SW304). • Sensor correction value is not suitable. Set it to a suitable value. • Specification of the Thermocouple or RTD is improper. • AC is leaking into thermocouple or the RTD circuit. Use an ungrounded type sensor. • There may be equipment that interferes with, or makes noise near the controller. Keep equipment that interferes with or makes noise away from the controller.

<Key operation>

Problem	Possible cause and solution
<ul style="list-style-type: none"> • Unable to set the SV, P, I, D, proportional cycle, alarm value, etc. • The values do not change by the ,  keys. 	<ul style="list-style-type: none"> • Set value lock (Lock 1 or Lock 2) is selected. Release the lock selection. • AT (Auto-tuning) is performing. Cancel AT.
The setting indication does not change within the input range even if the  ,  keys are pressed, and new values are unable to be set.	<ul style="list-style-type: none"> • SV high limit or SV low limit in Auxiliary function setting mode 1 may be set at the point where the value does not change. Set it to a suitable value while in Auxiliary function setting mode 1.
Program control does not start even if the  key is pressed in the Program mode.	<ul style="list-style-type: none"> • Step time has not been set. Set the step time.

<Control>

Problem	Possible cause and solution
PV does not rise.	<ul style="list-style-type: none"> • Thermocouple or RTD is burnt out. Replace the sensor. • Check whether the lead wire of thermocouple or RTD is securely mounted to the instrument terminals.
Control is not performing. (Only PV display is indicated.)	<ul style="list-style-type: none"> • Control output OFF function is working. Press the  key to cancel Control output OFF function. • Program mode is selected. To start Program control, press the  key. To perform Fixed value control, press the  key for approx. 3 sec while holding down the  key.
Control output (OUT) remains in an ON status.	<ul style="list-style-type: none"> • OUT low limit value is set to 100% or higher in Auxiliary function setting mode 2. Set it to a suitable value.
Control output (OUT) remains in an OFF status.	<ul style="list-style-type: none"> • OUT high limit value is set to 0% or less in Auxiliary function setting mode 2. Set it to a suitable value.











For all other malfunctions, please contact our main office or dealers.

13. Character Table







<Main setting mode>

Character	Item	Default	Data
	SV	0°C	

<Sub setting mode>

Character	Item	Default	Data
	Set value memory number	1	
	AT Perform/Cancel	AT Cancel	
	Proportional band	2.5%	
	Integral time	200 sec	
	Derivative time	50 sec	
	Proportional cycle	R/M: 30 sec, S/M: 3 sec	
	Manual reset	0.0°C	
	Alarm 1 value	0°C	
	Alarm 2 value	0°C	
	Loop break alarm time	0 minutes	
	Loop break alarm span	0°C	

<Auxiliary function setting mode 1>

Character	Item	Default	Data
	Set value lock	Unlock	
	SV high limit	400°C	
	SV low limit	0°C	
	Sensor correction	0.0°C	
	Instrument number	0	
	Communication speed	9600bps	
	Communication protocol	Shinko protocol	

<Auxiliary function setting mode 2>

Character	Item	Default	Data
41LH	Scaling high limit value	1370°C	
41LL	Scaling low limit value	-200°C	
F1LT	PV filter time constant	0.0 sec	
0LH□	OUT high limit value	100%	
0LL□	OUT low limit value	0%	
H94□	OUT ON/OFF hysteresis	1.0°C	
A1Ln	Alarm 1 action Energized/De-energized	Energized	
A2Ln	Alarm 2 action Energized/De-energized	Energized	
A1H9	Alarm 1 hysteresis	1.0°C	
A2H9	Alarm 2 hysteresis	1.0°C	
A1d9	Alarm 1 action delay time	0 sec	
A2d9	Alarm 2 action delay time	0 sec	
P58□	Indication when control output OFF	OFF on the PV display	
rA1U	SV rise rate	0°C/minute	
rA1d	SV fall rate	0°C/minute	

<Program mode>

Character	Item	Default	Data
Proc	Fixed value control/Program control	Fixed value control	
T_1□	Step 1 time	00.00	
T_2□	Step 2 time	00.00	
T_3□	Step 3 time	00.00	
T_4□	Step 4 time	00.00	
T_5□	Step 5 time	00.00	
T_6□	Step 6 time	00.00	
T_7□	Step 7 time	00.00	

***** Inquiries *****

For any inquiries about this unit, please contact the vendor where you purchased the unit after checking the following.

[Example]

- Model ----- FCS-23A-R/M
- Input type ----- K
- Option ----- A2, C5
- Serial number ----- No. xxxxxx

In addition to the above, please let us know the details of the malfunction, if any, and the operating conditions.

SHINKO TECHNOS CO., LTD. OVERSEAS DIVISION

Head Office: 2-5-1, Senbahigashi, Minoo, Osaka, Japan

URL: <http://www.shinko-technos.co.jp>

E-mail: overseas@shinko-technos.co.jp

Tel : 81-72-727-6100

Fax: 81-72-727-7006