

To prevent accidents arising from the misuse of this indicator, please ensure the operator receives this manual.

**Warning**

Turn the power supply to the instrument off before wiring or checking.  
Working on or touching the terminal with the power switched on may result in severe injury or death due to electrical shock.

# 1. System Configuration

## 1.1 When Using USB Communication Cable CMC-001-1 (Sold Separately)

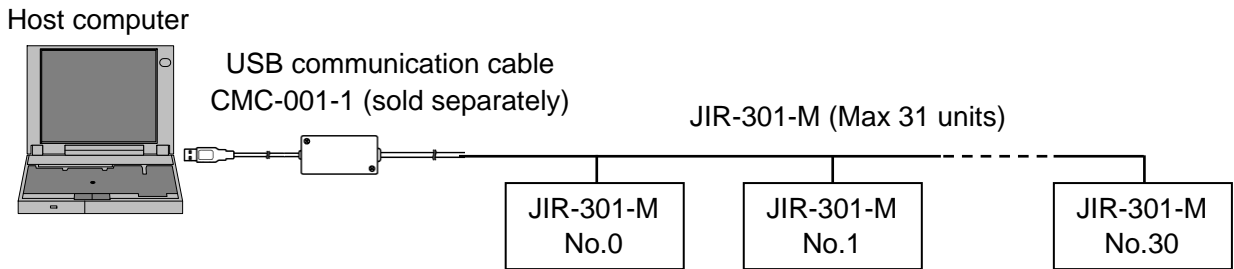

(Fig. 1.1-1)

## 1.2 When Using Communication Converter IF-400 (Sold Separately)

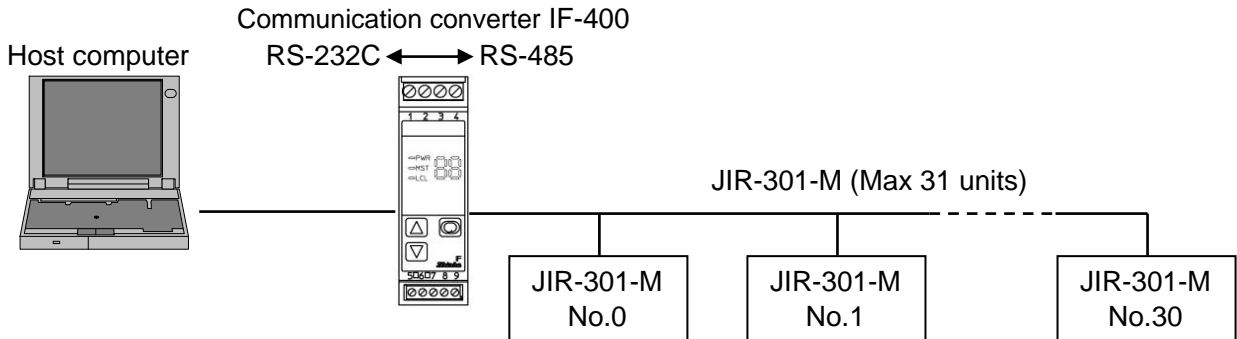

(Fig. 1.2-1)

# 2. Wiring

## 2.1 When Using USB Communication Cable CMC-001-1 (Sold Separately)

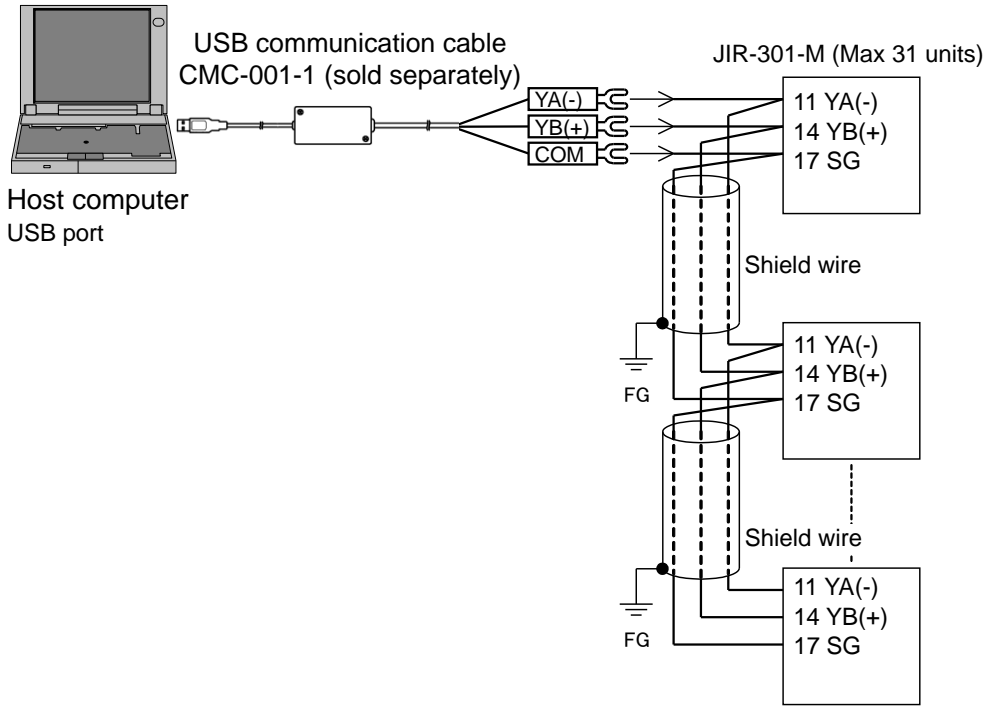

(Fig. 2.1-1)

## 2.2 When Using Communication Converter IF-400 (Sold Separately)

### • D-sub 25-pin connector

### • D-sub 9-pin connector

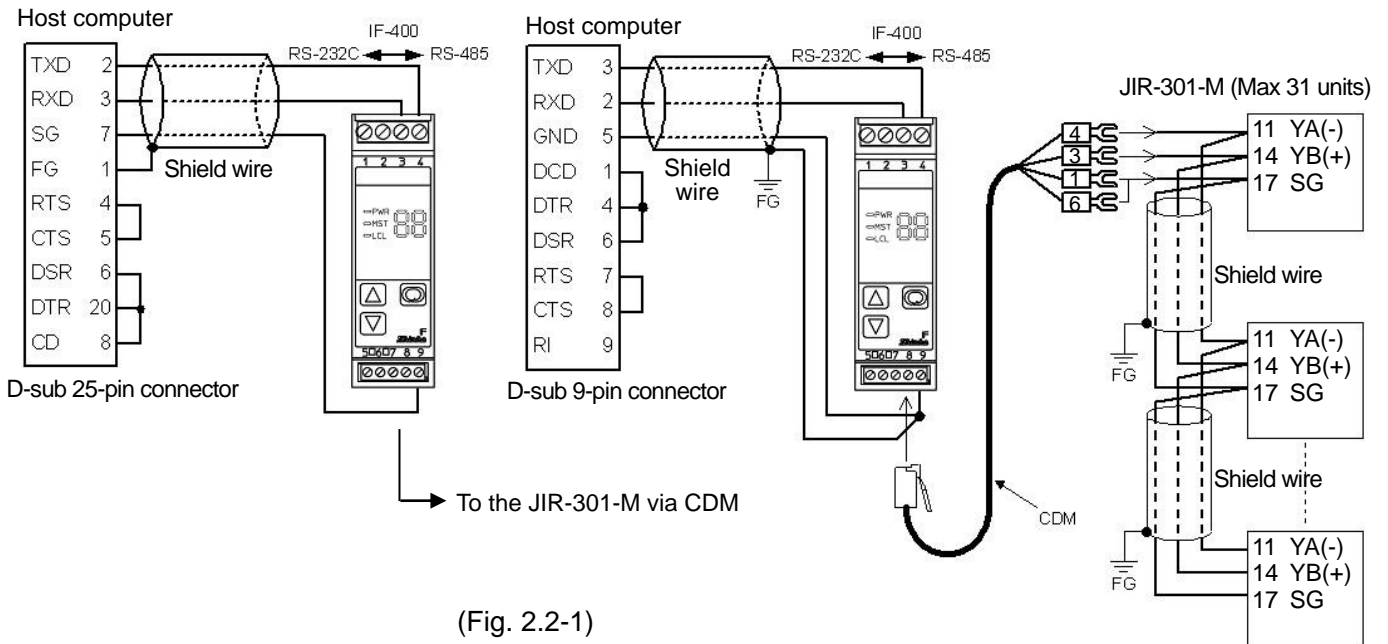

(Fig. 2.2-1)

### Shield Wire

Connect only one end of the shield to the FG to avoid a ground loop. If both ends of the shield wire are connected to the FG, the circuit will be closed, resulting in a ground loop. This may cause noise.

### Be sure to ground the FG.

Recommended cable: OTSC-VB 2PX0.5SQ (made by Onamba Co., Ltd.) or equivalent (Use a twisted pair cable.)

### Terminator (Terminal Resistor)

Communication converter IF-400 (sold separately) has a built-in terminator.

The terminator is mounted at the end of the wire when connecting multiple peripheral devices to a personal computer. The terminator prevents signal reflection and disturbance.

Do not connect a terminator to the communication line because each JIR-301-M has built-in pull-up and pull-down resistors.

## 3. Setting Communication Parameters

Set communication parameters in Auxiliary Function Setting Mode 1.

To enter Auxiliary Function Setting Mode 1, press and hold the DOWN key and MODE key (in that order) together for approx. 3 seconds in PV/SV Display Mode.

Press the MODE key 3 times. The unit will move to [Communication protocol].

Use the UP or DOWN key for making a selection or setting values.

To register the set data, press the MODE key.

Character Factory Default	Name, Function, Setting Range
cñ4L noñL	<b>Communication protocol</b> <ul style="list-style-type: none"> <li>• Selects communication protocol.</li> <li>• noñL : Shinko protocol</li> <li>   ñodR : MODBUS ASCII mode</li> <li>   ñodr : MODBUS RTU mode</li> <li>   bnñL : Shinko protocol (Block Read/Write available)</li> <li>   bñdR : MODBUS ASCII mode (Block Read/Write available)</li> <li>   bñdr : MODBUS RTU mode (Block Read/Write available)</li> </ul>
cñna □□□0	<b>Instrument number</b> <ul style="list-style-type: none"> <li>• Sets the individual instrument number of this unit. (The instrument numbers should be set one by one when multiple instruments are connected in Serial communication.)</li> <li>• Setting range: 0 to 95</li> </ul>
cñ4P □□96	<b>Communication speed</b> <ul style="list-style-type: none"> <li>• Selects a communication speed equal to that of the host computer.</li> <li>• □□24 : 2400 bps</li> <li>   □□48 : 4800 bps</li> <li>   □□96 : 9600 bps</li> <li>   □192 : 19200 bps</li> <li>   □384 : 38400 bps</li> </ul>
cñPr EñEn	<b>Parity</b> <ul style="list-style-type: none"> <li>• Selects the parity.</li> <li>• Available when MODBUS ASCII mode or MODBUS RTU mode is selected in [Communication protocol].</li> <li>• nonE : No parity</li> <li>   EñEn : Even</li> <li>   odd□ : Odd</li> </ul>
cñ4F □□□1	<b>Stop bit</b> <ul style="list-style-type: none"> <li>• Selects the stop bit.</li> <li>• Available when MODBUS ASCII mode or MODBUS RTU mode is selected in [Communication protocol].</li> <li>• □□□1 : 1 bit</li> <li>   □□□2 : 2 bits</li> </ul>

Press the MODE key.

The unit will revert to the PV/SV Display Mode.

Settings are complete.

## 4. Communication Procedure

Communication starts with command transmission from the host computer (hereafter Master), and ends with the response of the JIR-301-M (hereafter Slave).

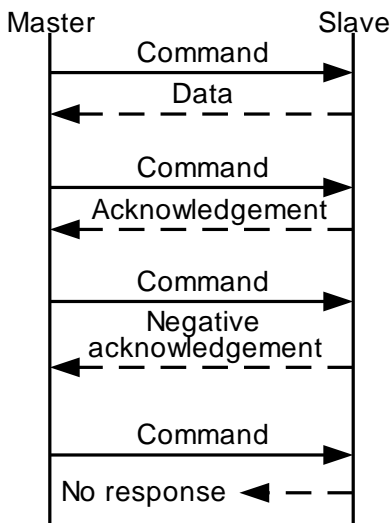

(Fig. 4-1)

- **Response with data**

When the master sends the Read command, the slave responds with the corresponding set value or current status.

- **Acknowledgement**

When the master sends the Write command, the slave responds by sending acknowledgement after the processing is terminated.

- **Negative acknowledgement**

When the master sends a non-existent command or value out of the setting range, the slave returns a negative acknowledgement.

- **No response**

The slave will not respond to the master in the following cases:

- Global address (Shinko protocol) is set.
- Broadcast address (MODBUS protocol) is set.
- Communication error (framing error, parity error)
- Checksum error (Shinko protocol), LRC discrepancy (MODBUS ASCII mode), CRC-16 discrepancy (MODBUS RTU mode)

### Communication timing of the RS-485 (C5 option)

#### Master side (Take note while programming)

When the master starts transmission through the RS-485 communication line, the master is arranged so as to provide an idle status (mark status) transmission period of 1 or more characters before sending the command to ensure synchronization on the receiving side.

Set the program so that the master can disconnect the transmitter from the communication line within a 1 character transmission period after sending the command in preparation for reception of the response from the slave.

To avoid collision of transmissions between the master and the slave, send the next command after carefully checking that the master has received the response.

If a response to the command is not returned due to communication errors, set the Retry Processing to send the command again. (It is recommended to execute Retry twice or more.)

#### Slave side

When the slave starts transmission through the RS-485 communication line, the slave is arranged so as to provide an idle status (mark status) transmission period of 1 or more characters before sending the response to ensure synchronization on the receiving side.

The slave is arranged so as to disconnect the transmitter from the communication line within a 1 character transmission period after sending the response.

# 5. Shinko Protocol

## 5.1 Transmission Mode

Shinko protocol is composed of ASCII codes.

Hexadecimal (0 to 9, A to F), which is divided into high order (4-bit) and low order (4-bit) out of 8-bit binary data in command is transmitted as ASCII characters.

Data format    Start bit: 1 bit  
                     Data bit: 7 bits  
                     Parity: Even  
                     Stop bit: 1 bit

Error detection: Checksum

## 5.2 Command Configuration

All commands are composed of ASCII.

The data (set value, decimal number) is represented by a hexadecimal number.

The negative numbers are represented in 2's complement.

Numerals written below the command represent number of characters.

### (1) Write command

#### • Write a single piece of data

Header (02H)	Address	Sub address (20H)	Command type (50H)	Data item	Data	Checksum	Delimiter (03H)
1	1	1	1	4	4	2	1

#### • Write multiple pieces of data

Header (02H)	Address	Sub address (20H)	Command type (54H)	Data item	Data	Checksum	Delimiter (03H)
1	1	1	1	4	4 x n	2	1

n: Amount of data

### (2) Read command

#### • Read a single piece of data

Header (02H)	Address	Sub address (20H)	Command type (20H)	Data item	Checksum	Delimiter (03H)
1	1	1	1	4	2	1

#### • Read multiple pieces of data

Header (02H)	Address	Sub address (20H)	Command type (24H)	Data item	Read data amount n	Checksum	Delimiter (03H)
1	1	1	1	4	4	2	1

### (3) Response with data

#### • Response to 'Read a single piece of data'

Header (06H)	Address	Sub address (20H)	Command type (20H)	Data item	Data	Checksum	Delimiter (03H)
1	1	1	1	4	4	2	1

#### • Response to 'Read multiple pieces of data'

Header (06H)	Address	Sub address (20H)	Command type (24H)	Data item	Data	Checksum	Delimiter (03H)
1	1	1	1	4	4 x n	2	1

n: Amount of data

**(4) Acknowledgement**

Header (06H)	Address	Checksum	Delimiter (03H)
1	1	2	1

**(5) Negative acknowledgement**

Header (15H)	Address	Error code	Checksum	Delimiter (03H)
1	1	1	2	1

**Header:** Control code to represent the beginning of the command or the response. ASCII is used.

Write command, Read command: STX (02H) fixed

Response with data, Acknowledgement: ACK (06H) fixed

Negative acknowledgement: NAK (15H) fixed

**Instrument number (Address):** Numbers by which the master discerns each slave.

Instrument number 0 to 94 and Global address 95.

ASCII (20H to 7FH) is used by adding 20H to instrument numbers 0 to 95 (00H to 5FH).

95 (7FH) is called the Global address, which is used when the same command is sent to all the slaves connected. However, the response is not returned.

**Sub address:** 20H fixed

**Command type:** Code to discern Write command and Read command

Command Type	Contents	Description
20H	Read a single piece of data	Reads a single piece of data.
24H	Read multiple pieces of data	Reads consecutive multiple pieces of data. (Amount of data: Max. 100)
50H	Write a single piece of data	Writes a single piece of data.
54H	Write multiple pieces of data	Writes consecutive multiple pieces of data. (Amount of data: Max. 100)

**Notes about Reading/Writing multiple pieces of data**

When reading/writing multiple pieces of data, as it takes time until slave sends response data, the master determines no response time based on timeout period below after sending a command.

**Timeout period calculation:** 6 ms x Amount of data

**Data item:** Classification of the command object.

Composed of 4-digit hexadecimal numbers, using ASCII.

Refer to Section “7. Communication Command Table” (pp. 24-31).

**Data:** The contents of data (values) differ depending on the Write command.

Composed of 4-digit hexadecimal numbers, using ASCII.

Refer to Section “7. Communication Command Table” (pp. 24-31).

**Checksum:** 2-character data to detect communication errors.

Refer to “5.3 Checksum Calculation” (p.7).

**Delimiter:** Control code to represent the end of command.

ASCII code ETX (03H) fixed

**Error code:** Represents an error type using ASCII.

Error Code	Contents
1 (31H)	Non-existent command
2 (32H)	Not used
3 (33H)	Value outside the setting range
4 (34H)	Status unable to be written (e.g. AT is performing.)
5 (35H)	During setting mode by keypad operation

### 5.3 Checksum Calculation

Checksum is used to detect receiving errors in the command or data.

Set the program for the master side as well to calculate the checksum of the response data from the slaves so that communication errors can be checked.

The ASCII code (hexadecimal) corresponding to the characters which range from the address (instrument number) to that before the checksum is converted to binary notation, and the total value is calculated.

The lower one byte of the total value is converted to 2's complement, and then to hexadecimal numbers, that is, ASCII code for the checksum.

- 1's complement: Reverse each binary bit. 0 will become 1 and vice versa.
- 2's complement: Add 1 to 1's complement.

#### Checksum calculation example:

A1 value (0001H) is written to 600°C (0258H)

Address (instrument number): 0 (20H)

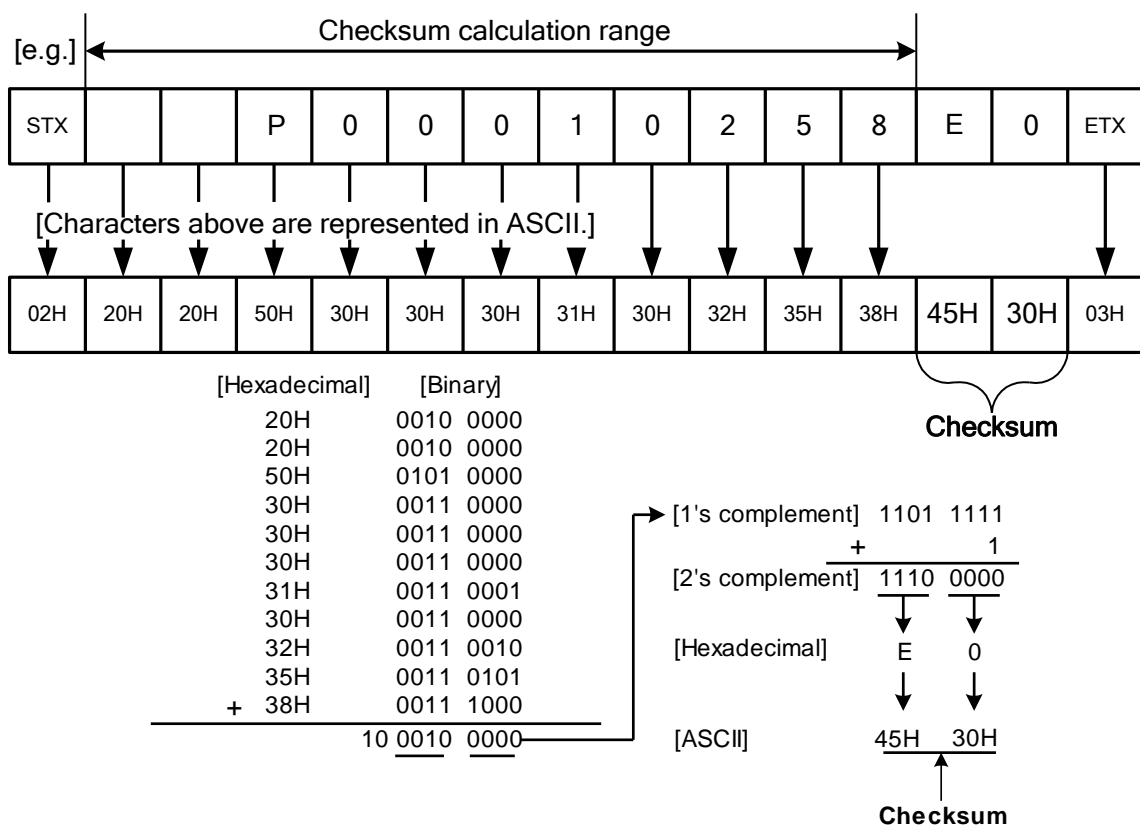

## 5.4 Command Example

Numerals written below the command represent number of characters.

### (1) Read [Address 1, PV (0080H)]

- Read command from the master

Header (02H)	Address (21H)	Sub address (20H)	Command type (20H)	Data item [0080H] (30H 30H 38H 30H)	Checksum (44H 37H)	Delimiter (03H)
1	1	1	1	4	2	1

- A response from the slave in normal status [When PV is 25°C (0019H)]

Header (06H)	Address (21H)	Sub address (20H)	Command type (20H)	Data item [0080H] (30H 30H 38H 30H)	Data [0019H] (30H 30H 31H 39H)	Checksum (30H 44H)	Delimiter (03H)
1	1	1	1	4	4	2	1

### (2) Read [Address 1, A1 value (0001H)]

- Read command from the master

Header (02H)	Address (21H)	Sub address (20H)	Command type (20H)	Data item [0001H] (30H 30H 30H 31H)	Checksum (44H 45H)	Delimiter (03H)
1	1	1	1	4	2	1

- A response from the slave in normal status [A1 value is 600°C (0258H)]

Header (06H)	Address (21H)	Sub address (20H)	Command type (20H)	Data item [0001H] (30H 30H 30H 31H)	Data [0258H] (30H 32H 35H 38H)	Checksum (30H 46H)	Delimiter (03H)
1	1	1	1	4	4	2	1

### (3) Write [Address 1, A1 value (0001H)]

- Write command from the master [when writing A1 value to 600°C (0258H)]

Header (02H)	Address (21H)	Sub address (20H)	Command type (50H)	Data item [0001H] (30H 30H 30H 31H)	Data [0258H] (30H 32H 35H 38H)	Checksum (44H 46H)	Delimiter (03H)
1	1	1	1	4	4	2	1

- A response from the slave in normal status

Header (06H)	Address (21H)	Checksum (44H 46H)	Delimiter (03H)
1	1	2	1



**(4) Read (Address 1, 25 commands from input type)**

- Read command from the master

Header (02H)	Address (21H)	Sub address (20H)	Command type (24H)	Data item [0001H] (30H 30H 30H 31H)	Read data amount 25 [0019H] (30H 30H 31H 39H)	Checksum (31H 30H)	Delimiter (03H)
1	1	1	1	4	4	2	1

- A response from the slave in normal status

Header (06H)	Address (21H)	Sub address (20H)	Command type (24H)	Data item [0001H] (30H 30H 30H 31H)
1	1	1	1	4

Data [00000000055A · · · 0000] (30H 30H 30H 30H 30H 30H 30H 30H 30H 30H 35H 35H 41H · · · 30H 30H 30H 30H)					Checksum (41H 38H)	Delimiter (03H)
100 (4 x 25)					2	1

Response data is as follows:

	Data Item	Data	Data (Converted to Hexadecimal)
0001H	Input type	K [-200 - 1370°C]	0000H
0002H	Scaling high limit	1370°C	055AH
0003H	Scaling low limit	-200°C	FF38H
0004H	Decimal point place	No decimal point	0000H
0005H	A1 type	No alarm action	0000H
0006H	A2 type	No alarm action	0000H
0007H	A3 type	No alarm action	0000H
0008H	A4 type	No alarm action	0000H
0009H	A1 value	0°C	0000H
000AH	A2 value	0°C	0000H
000BH	A3 value	0°C	0000H
000CH	A4 value	0°C	0000H
000DH	A4 high limit value	0°C	0000H
000EH	A1 hysteresis	1.0°C	000AH
000FH	A2 hysteresis	1.0°C	000AH
0010H	A3 hysteresis	1.0°C	000AH
0011H	A4 hysteresis	1.0°C	000AH
0012H	A1 Energized/De-energized	Energized	0000H
0013H	A2 Energized/De-energized	Energized	0000H
0014H	A3 Energized/De-energized	Energized	0000H
0015H	A4 Energized/De-energized	Energized	0000H
0016H	A1 delay time	0 sec	0000H
0017H	A2 delay time	0 sec	0000H
0018H	A3 delay time	0 sec	0000H
0019H	A4 delay time	0 sec	0000H

**(5) Write (Address 1, 25 commands from input type)**

**(e.g.) 25 commands from the input type are shown below.**

	Data Item	Data	Data (Converted to Hexadecimal)
0001H	Input type	K [-200.0 - 400.0°C]	0001H
0002H	Scaling high limit	400.0°C	0FA0H
0003H	Scaling low limit	0.0°C	0000H
0004H	Decimal point place	xxx.x (1 digit after decimal point)	0001H
0005H	A1 type	High limit alarm	0001H
0006H	A2 type	High limit alarm	0001H
0007H	A3 type	Low limit alarm	0002H
0008H	A4 type	High/Low limit range alarm	0005H
0009H	A1 value	250.0°C	09C4H
000AH	A2 value	300.0°C	0BB8H
000BH	A3 value	150.0°C	05DCH
000CH	A4 value	180.0°C	0708H
000DH	A4 high limit value	220.0°C	0898H
000EH	A1 hysteresis	1.0°C	000AH
000FH	A2 hysteresis	1.0°C	000AH
0010H	A3 hysteresis	1.0°C	000AH
0011H	A4 hysteresis	1.0°C	000AH
0012H	A1 Energized/De-energized	Energized	0000H
0013H	A2 Energized/De-energized	Energized	0000H
0014H	A3 Energized/De-energized	Energized	0000H
0015H	A4 Energized/De-energized	Energized	0000H
0016H	A1 delay time	0 sec	0000H
0017H	A2 delay time	0 sec	0000H
0018H	A3 delay time	0 sec	0000H
0019H	A4 delay time	0 sec	0000H

- Write command from the master (When writing the above data)

Header (02H)	Address (21H)	Sub address (20H)	Command type (54H)	Data item [0001H] (30H 30H 30H 31H)
1	1	1	1	4

Data [00010FA00000 · · · 0000] (30H 30H 30H 31H 30H 46H 41H 30H 30H 30H 30H 30H · · · 30H 30H 30H 30H)	Checksum (44H 34H)	Delimiter (03H)
100 (4 x 25)	2	1

- Response from the slave in normal status

Header (06H)	Address (21H)	Checksum (44H 46H)	Delimiter (03H)
1	1	2	1

# 6. MODBUS Protocol

## 6.1 Transmission Mode

There are 2 transmission modes (ASCII and RTU) in MODBUS protocol.

### 6.1.1 ASCII Mode

Hexadecimal (0 to 9, A to F), which is divided into high order (4-bit) and low order (4-bit) out of 8-bit binary data in command is transmitted as ASCII characters.

Data format      Start bit: 1 bit  
                          Data bit: 7 bits (Selectable)  
                          Parity: Even (No parity, Odd) (Selectable)  
                          Stop bit: 1 bit (2 bits) (Selectable)

Error detection : LRC (Longitudinal Redundancy Check)

### 6.1.2 RTU Mode

8-bit binary data in command is transmitted as it is.

Data format      Start bit: 1 bit  
                          Data bit: 8 bits  
                          Parity: No parity (Even, Odd) (Selectable)  
                          Stop bit: 1 bit (2 bits) (Selectable)

Error detection: CRC-16 (Cyclic Redundancy Check)

## 6.2 Data Communication Interval

### 6.2.1 ASCII Mode

No communication interval limit between characters

### 6.2.2 RTU Mode

1.5 character transmission times or less  
 (Communication speed 2400, 4800, 9600, 19200 bps: 1.5 character transmission times,  
 Communication speed 38400 bps: 750  $\mu$ s)

To transmit continuously, an interval between characters which consist of one message, must be within 1.5 character transmission times.

If an interval lasts longer than 1.5 character transmission times, the JIR-301-M assumes that transmission from the master is finished, which results in a communication error, and will not return a response.

## 6.3 Message Configuration

### 6.3.1 ASCII Mode

ASCII mode message is configured to start by Header [: (colon) (3AH)], and end by Delimiter [CR (carriage return) (0DH) + LF (Line feed) (0AH)].

Data: Max. 2 x 252 characters

Header (:)	Slave address	Function code	Data	Error check LRC	Delimiter (CR)	Delimiter (LF)
---------------	------------------	------------------	------	--------------------	-------------------	-------------------

### 6.3.2 RTU Mode

RTU mode is configured to start after idle time is processed for more than 3.5 character transmissions, and end after idle time is processed for more than 3.5 character transmissions.

(Communication speed 2400, 4800, 9600, 19200 bps: 3.5 character transmission times,  
 Communication speed 38400 bps: 1.75 ms)

Data: Max. 252 bytes

3.5 idle characters	Slave address	Function code	Data	Error check CRC-16	3.5 idle characters
------------------------	------------------	------------------	------	-----------------------	------------------------

### (1) Slave Address

Slave address is an individual instrument number on the slave side, and is set within the range 0 to 95 (00H to 5FH). The master identifies slaves by the slave address of the requested message. The slave informs the master which slave is responding to the master by placing its own address in the response message.

Slave address (00H, Broadcast address) can identify all the slaves connected. However, slaves do not respond.

### (2) Function Code

The function code is the command code for the slave to undertake one of the following actions.

**(Table 6.3-1)**

Type	Function Code	Contents
Data access	03 (03H)	Reads a single or multiple piece(s) of data from slave(s). (Up to 100 pieces of data can be read per command.)
	04 (04H)	Reads status from slave(s). (Up to 100 pieces of data can be read per command.)
	06 (06H)	Writes a single piece of data to slave(s).
	16 (10H)	Writes multiple pieces of data to slave(s). (Up to 100 pieces of data can be written per command.)

The function code is used to discern whether the response is normal (acknowledgement) or if any error (negative acknowledgement) has occurred when the slave returns the response message to the master.

When acknowledgement is returned, the slave simply returns the original function code.

When negative acknowledgement is returned, the MSB of the original function code is set as 1 for the response.

For example, if the master sends request message setting 10H to the function code by mistake, slave returns 90H by setting the MSB to 1, because the former is an illegal function.

For negative acknowledgement, the exception codes below are set to the data of the response message, and returned to the master in order to inform it of what kind of error has occurred.

**(Table 6.3-2)**

Exception Code	Contents
1 (01H)	Illegal function (Non-existent function)
2 (02H)	Illegal data address (Non-existent data address)
3 (03H)	Illegal data value (Value out of the setting range)
17 (11H)	Shinko protocol error code 4 (Status unable to be written)
18 (12H)	Shinko protocol error code 5 (During setting mode by keypad operation)

### (3) Data

Data differs depending on the function code.

A request message from the master is composed of a data item, amount of data and setting data.

A response message from the slave is composed of the byte count, data and exception codes in negative acknowledgements, corresponding to the request message.

The effective range of data is -32768 to 32767 (8000H to 7FFFH).

Refer to Section "7. Communication Command Table" (pp.24 to 31).

#### (4) Error Check

##### ASCII Mode

After calculating LRC (Longitudinal Redundancy Check) from the slave address to the end of data, the calculated 8-bit data is converted to two ASCII characters, and are appended to the end of message.

##### How to Calculate LRC

- ① Create a message in RTU mode.
- ② Add all the values from the slave address to the end of data. This is assumed as X.
- ③ Make a complement for X (bit reverse). This is assumed as X.
- ④ Add a value of 1 to X. This is assumed as X.
- ⑤ Set X as an LRC to the end of the message.
- ⑥ Convert the whole message to ASCII characters.

##### RTU Mode

After calculating CRC-16 (Cyclic Redundancy Check) from the slave address to the end of the data, the calculated 16-bit data is appended to the end of message in sequence from low order to high order.

##### How to calculate CRC-16

In the CRC-16 system, the information is divided by the polynomial series. The remainder is added to the end of the information and transmitted. The generation of a polynomial series is as follows:

(Generation of polynomial series:  $X^{16} + X^{15} + X^2 + 1$ )

- ① Initialize the CRC-16 data (assumed as X) (FFFFH).
- ② Calculate exclusive OR (XOR) with the 1st data and X. This is assumed as X.
- ③ Shift X one bit to the right. This is assumed as X.
- ④ When a carry is generated as a result of the shift, XOR is calculated by X of ③ and the fixed value (A001H). This is assumed as X. If a carry is not generated, go to step ⑤.
- ⑤ Repeat steps ③ and ④ until shifting 8 times.
- ⑥ XOR is calculated with the next data and X. This is assumed as X.
- ⑦ Repeat steps ③ to ⑤.
- ⑧ Repeat steps ③ to ⑤ up to the final data.
- ⑨ Set X as CRC-16 to the end of message in sequence from low order to high order.

## 6.4 Message Example

### 6.4.1 ASCII Mode

Numerals written below the command represent the number of characters.

#### (1) Read [Slave address 1, PV (0080H)]

- A request message from the master

Header (3AH)	Slave address (30H 31H)	Function code (30H 33H)	Data item [0080H] (30H 30H 38H 30H)	Amount of data [0001H] (30H 30H 30H 31H)	Error check LRC (37H 42H)	Delimiter CR+LF (0DH 0AH)
1	2	2	4	4	2	2

- Response message from the slave in normal status [When PV is 600°C (0258H)]

Header (3AH)	Slave address (30H 31H)	Function code (30H 33H)	Response byte count [02H] (30H 32H)	Data [0258H] (30H 32H 35H 38H)	Error check LRC (41H 30H)	Delimiter CR+LF (0DH 0AH)
1	2	2	2	4	2	2

#### (2) Write [Slave address 1, A1 value (0001H)]

- A request message from the master [When writing A1 value to 600°C (0258H)]

Header (3AH)	Slave address (30H 31H)	Function code (30H 36H)	Data item [0001H] (30H 30H 30H 31H)	Data [0258H] (30H 32H 35H 38H)	Error check LRC (39H 45H)	Delimiter CR+LF (0DH 0AH)
1	2	2	4	4	2	2

- Response message from the slave in normal status

Header (3AH)	Slave address (30H 31H)	Function code (30H 36H)	Data item [0001H] (30H 30H 30H 31H)	Data [0258H] (30H 32H 35H 38H)	Error check LRC (39H 45H)	Delimiter CR+LF (0DH 0AH)
1	2	2	4	4	2	2

- Response message from the slave in exception (error) status (When a value out of the setting range is set)

The function code MSB is set to 1 for the response message in exception (error) status [86H (38H 36H)].

The exception code 03H (30H 33H: Value out of the setting range) is returned (error).

Header (3AH)	Slave address (30H 31H)	Function code (38H 36H)	Exception code [03H] (30H 33H)	Error check LRC (37H 36H)	Delimiter CR+LF (0DH 0AH)
1	2	2	2	2	2

#### (3) Read [Slave address 1, A1 value (0001H)]

- A request message from the master

Header (3AH)	Slave address (30H 31H)	Function code (30H 33H)	Data item [0001H] (30H 30H 30H 31H)	Amount of data [0001H] (30H 30H 30H 31H)	Error check LRC (46H 41H)	Delimiter CR+LF (0DH 0AH)
1	2	2	4	4	2	2

- Response message from the slave in normal status [When A1 value is 600°C (0258H)]

Header (3AH)	Slave address (30H 31H)	Function code (30H 33H)	Response byte count [02H] (30H 32H)	Data [0258H] (30H 32H 35H 38H)	Error check LRC (41H 30H)	Delimiter CR+LF (0DH 0AH)
1	2	2	2	4	2	2

- Response message from the slave in exception (error) status (When data item is incorrect)

The function code MSB is set to 1 for the response message in exception (error) status [83H (38H 33H)].

The exception code 02H (30H 32H: Non-existent data address) is returned (error).

Header (3AH)	Slave address (30H 31H)	Function code (38H 33H)	Exception code [02H] (30H 32H)	Error check LRC (37H 41H)	Delimiter CR+LF (0DH 0AH)
1	2	2	2	2	2

**(4) Read [Slave address 1, 25 commands from input type]**

- A request message from the master

Header (3AH)	Slave address (30H 31H)	Function code (30H 33H)	Data item [0001H] (30H 30H 30H 31H)	Amount of data [0019H] (30H 30H 31H 39H)	Error check LRC (45H 32H)	Delimiter CR+LF (0DH 0AH)
1	2	2	4	4	2	2

- Response message from the slave in normal status

Header (3AH)	Slave address (30H 31H)	Function code (30H 33H)	Response byte count [32H] (33H 32H)
1	2	2	2

Data [0000055AFF38 . . . 0000] (30H 30H 30H 30H 30H 35H 35H 41H 46H 46H 33H 38H . . . 30H 30H 30H 30H)	Error check LRC (32H 32H)	Delimiter CR+LF (0DH 0AH)
100 (4 x 25)	2	2

Response data is as follows:

	Data Item	Data	Data (Converted to Hexadecimal)
0001H	Input type	K [-200 - 1370°C]	0000H
0002H	Scaling high limit	1370°C	055AH
0003H	Scaling low limit	-200°C	FF38H
0004H	Decimal point place	No decimal point	0000H
0005H	A1 type	No alarm action	0000H
0006H	A2 type	No alarm action	0000H
0007H	A3 type	No alarm action	0000H
0008H	A4 type	No alarm action	0000H
0009H	A1 value	0°C	0000H
000AH	A2 value	0°C	0000H
000BH	A3 value	0°C	0000H
000CH	A4 value	0°C	0000H
000DH	A4 high limit value	0°C	0000H
000EH	A1 hysteresis	1.0°C	000AH
000FH	A2 hysteresis	1.0°C	000AH
0010H	A3 hysteresis	1.0°C	000AH
0011H	A4 hysteresis	1.0°C	000AH
0012H	A1 Energized/De-energized	Energized	0000H
0013H	A2 Energized/De-energized	Energized	0000H
0014H	A3 Energized/De-energized	Energized	0000H
0015H	A4 Energized/De-energized	Energized	0000H
0016H	A1 delay time	0 sec	0000H
0017H	A2 delay time	0 sec	0000H
0018H	A3 delay time	0 sec	0000H
0019H	A4 delay time	0 sec	0000H

- (5) Write (Slave address 1, 25 commands from input type)  
 (e.g.) 25 commands from the input type are shown below.

	Data Item	Data	Data (Converted to Hexadecimal)
0001H	Input type	K [-200.0 - 400.0°C]	0001H
0002H	Scaling high limit	400.0°C	0FA0H
0003H	Scaling low limit	0.0°C	0000H
0004H	Decimal point place	xxx.x (1 digit after decimal point)	0001H
0005H	A1 type	High limit alarm	0001H
0006H	A2 type	High limit alarm	0001H
0007H	A3 type	Low limit alarm	0002H
0008H	A4 type	High/Low limit range alarm	0005H
0009H	A1 value	250.0°C	09C4H
000AH	A2 value	300.0°C	0BB8H
000BH	A3 value	150.0°C	05DCH
000CH	A4 value	180.0°C	0708H
000DH	A4 high limit value	220.0°C	0898H
000EH	A1 hysteresis	1.0°C	000AH
000FH	A2 hysteresis	1.0°C	000AH
0010H	A3 hysteresis	1.0°C	000AH
0011H	A4 hysteresis	1.0°C	000AH
0012H	A1 Energized/De-energized	Energized	0000H
0013H	A2 Energized/De-energized	Energized	0000H
0014H	A3 Energized/De-energized	Energized	0000H
0015H	A4 Energized/De-energized	Energized	0000H
0016H	A1 delay time	0 sec	0000H
0017H	A2 delay time	0 sec	0000H
0018H	A3 delay time	0 sec	0000H
0019H	A4 delay time	0 sec	0000H

- A request message from the master (When writing the above data)

Header (3AH)	Slave address (30H 31H)	Function code (31H 30H)	Data item [0001H] (30H 30H 30H 31H)	Amount of data [0019H] (30H 30H 31H 39H)	Byte count [32H] (33H 32H)	
1	2	2	4	4	2	

Data [00010FA0 · · · 0000] (30H 30H 30H 31H 30H 46H 41H 30H · · · 30H 30H 30H 30H)	Error check LRC (41H 31H)	Delimiter CR+LF (0DH 0AH)
100 (4 x 25)	2	2

- Response message from the slave in normal status

Header (3AH)	Slave address (30H 31H)	Function code (31H 30H)	Data item [0001H] (30H 30H 30H 31H)	Amount of data [0019H] (30H 30H 31H 39H)	Error check LRC (44H 35H)	Delimiter CR+LF (0DH 0AH)
1	2	2	4	4	2	2



## 6.4.2 RTU Mode

Numerals written below the command represent the number of characters.

### (1) Read [Slave address 1, PV (0080H)]

- A request message from the master

3.5 idle characters	Slave address (01H)	Function code (03H)	Data item (0080H)	Amount of data (0001H)	Error check CRC-16 (85E2H)	3.5 idle characters
	1	1	2	2	2	

- Response message from the slave in normal status [When PV is 600°C (0258H)]

3.5 idle characters	Slave address (01H)	Function code (03H)	Response byte count (02H)	Data (0258H)	Error check CRC-16 (B8DEH)	3.5 idle characters
	1	1	1	2	2	

### (2) Write [Slave address 1, A1 value (0001H)]

- A request message from the master [When A1 value is written to 600°C (0258H)]

3.5 idle characters	Slave address (01H)	Function code (06H)	Data item (0001H)	Data (0258H)	Error check CRC-16 (D890H)	3.5 idle characters
	1	1	2	2	2	

- Response message from the slave in normal status

3.5 idle characters	Slave address (01H)	Function code (06H)	Data item (0001H)	Data (0258H)	Error check CRC-16 (D890H)	3.5 idle characters
	1	1	2	2	2	

- Response message from the slave in exception (error) status (When a value out of the setting range is set) The function code MSB is set to 1 for the response message in exception (error) status, and 86H is returned.

The Exception code 03H (Value out of the setting range) is returned (error).

3.5 idle characters	Slave address (01H)	Function code (86H)	Exception code (03H)	Error check CRC-16 (0261H)	3.5 idle characters
	1	1	1	2	

### (3) Read [Slave address 1, A1 value (0001H)]

- A request message from the master

3.5 idle characters	Slave address (01H)	Function code (03H)	Data item (0001H)	Data (0001H)	Error check CRC-16 (D5CAH)	3.5 idle characters
	1	1	2	2	2	

- Response message from the slave in normal status [When A1 value is 600°C (0258H)]

3.5 idle characters	Slave address (01H)	Function code (03H)	Response byte count (02H)	Data (0258H)	Error check CRC-16 (B8DEH)	3.5 idle characters
	1	1	1	2	2	

- Response message from the slave in exception (error) status (When data item is incorrect) The function code MSB is set to 1 for the response message in exception (error) status, and 83H is returned. The Exception code 02H (Non-existent data address) is returned (error).

3.5 idle characters	Slave address (01H)	Function code (83H)	Exception code (02H)	Error check CRC-16 (C0F1H)	3.5 idle characters
	1	1	1	2	

#### (4) Read [Slave address 1, 25 commands from input type]

- A request message from the master

3.5 idle characters	Slave address (01H)	Function code (03H)	Data item (0001H)	Amount of data (0019H)	Error check CRC-16 (D5C0H)	3.5 idle characters
	1	1	2	2	2	

- Response message from the slave in normal status

3.5 idle characters	Slave address (01H)	Function code (03H)	Response byte count (32H)	Data (0000055AFF38 · · · 0000H)	Error check CRC-16 (15CDH)	3.5 idle characters
	1	1	1	50 (2×25)	2	

Response data is as follows:

	Data Item	Data	Data (Converted to Hexadecimal)
0001H	Input type	K [-200 - 1370°C]	0000H
0002H	Scaling high limit	1370°C	055AH
0003H	Scaling low limit	-200°C	FF38H
0004H	Decimal point place	No decimal point	0000H
0005H	A1 type	No alarm action	0000H
0006H	A2 type	No alarm action	0000H
0007H	A3 type	No alarm action	0000H
0008H	A4 type	No alarm action	0000H
0009H	A1 value	0°C	0000H
000AH	A2 value	0°C	0000H
000BH	A3 value	0°C	0000H
000CH	A4 value	0°C	0000H
000DH	A4 high limit value	0°C	0000H
000EH	A1 hysteresis	1.0°C	000AH
000FH	A2 hysteresis	1.0°C	000AH
0010H	A3 hysteresis	1.0°C	000AH
0011H	A4 hysteresis	1.0°C	000AH
0012H	A1 Energized/De-energized	Energized	0000H
0013H	A2 Energized/De-energized	Energized	0000H
0014H	A3 Energized/De-energized	Energized	0000H
0015H	A4 Energized/De-energized	Energized	0000H
0016H	A1 delay time	0 sec	0000H
0017H	A2 delay time	0 sec	0000H
0018H	A3 delay time	0 sec	0000H
0019H	A4 delay time	0 sec	0000H

**(5) Write (Slave address 1, 25 commands from input type)**

(e.g.) 25-command data from the input type are shown below.

	Data Item	Data	Data (Converted to Hexadecimal)
0001H	Input type	K [-200.0 - 400.0°C]	0001H
0002H	Scaling high limit	400.0°C	0FA0H
0003H	Scaling low limit	0.0°C	0000H
0004H	Decimal point place	xxx.x (1 digit after decimal point)	0001H
0005H	A1 type	High limit alarm	0001H
0006H	A2 type	High limit alarm	0001H
0007H	A3 type	Low limit alarm	0002H
0008H	A4 type	High/Low limit range alarm	0005H
0009H	A1 value	250.0°C	09C4H
000AH	A2 value	300.0°C	0BB8H
000BH	A3 value	150.0°C	05DCH
000CH	A4 value	180.0°C	0708H
000DH	A4 high limit value	220.0°C	0898H
000EH	A1 hysteresis	1.0°C	000AH
000FH	A2 hysteresis	1.0°C	000AH
0010H	A3 hysteresis	1.0°C	000AH
0011H	A4 hysteresis	1.0°C	000AH
0012H	A1 Energized/De-energized	Energized	0000H
0013H	A2 Energized/De-energized	Energized	0000H
0014H	A3 Energized/De-energized	Energized	0000H
0015H	A4 Energized/De-energized	Energized	0000H
0016H	A1 delay time	0 sec	0000H
0017H	A2 delay time	0 sec	0000H
0018H	A3 delay time	0 sec	0000H
0019H	A4 delay time	0 sec	0000H

- A request message from the master (When writing the above data)

3.5 idle characters	Slave address (01H)	Function code (10H)	Data item (0001H)	Amount of data (0019H)	Byte count (32H)
	1	1	2	2	1

Data (00010FA00000···0000H)	Error check CRC-16 (0412H)	3.5 idle characters
50 (2 x 25)	2	

- Response message from the slave in normal status

3.5 idle characters	Slave address (01H)	Function code (10H)	Data item (0001H)	Amount of data (0019H)	Error check CRC-16 (5003H)	3.5 idle characters
	1	1	2	2	2	

## 6.5 Diagnostics Function

MODBUS protocol has the following diagnostics functions.

- Echoes back the request message.
- Reads device identification information.

### 6.5.1 Message Configuration

#### ASCII mode

Header (:)	Slave address	Function code	Data	Error check LRC	Delimiter (CR)	Delimiter (LF)
---------------	------------------	------------------	------	--------------------	-------------------	-------------------

#### RTU mode

3.5 idle characters	Slave address	Function code	Data	Error check CRC-16	3.5 idle characters
------------------------	------------------	------------------	------	-----------------------	------------------------

#### (1) Slave address

Slave address is an individual instrument number on the slave side, and is set within the range 1 to 95 (01H to 5FH).

The master identifies slaves by the slave address of the requested message.

The slave informs the master which slave is responding to the master by placing its own address in the response message.

Diagnostics function is disabled for the Slave address 0 (00H, Broadcast address).

#### (2) Function code

The function code is the command code for the slave to undertake the following action types.

Type	Function Code	Sub-function Code	Contents
Diagnostics	08 (08H)	00 (0000H)	Echoes back the request message. (Up to 100 pieces of data can be echoed back per command)
	43 (2BH)	14 (0EH)	Reads device identification information.

Function code is used to discern whether the response is normal (acknowledgement) or if any error (negative acknowledgement) has occurred when the slave returns the response message to the master.

When acknowledgement is returned, the slave simply returns the original function code.

When negative acknowledgement is returned, the MSB of the original function code is set as 1 for the response. For example, when the master sends request message setting 0FH to the Reads device identification information 43 (2BH) sub-function code by mistake, slave returns ABH by setting the MSB to 1, because the former is a non-existent sub-function code.

For negative acknowledgement, the exception codes below are set to the data of the response message, and returned to the master in order to inform it of what kind of error has occurred.

Exception Code	Contents
1 (01H)	Illegal function (Non-existent function) Sub-function code is not correct.
2 (02H)	Illegal data address (Non-existent data address) For function code 43 (2BH): Object ID is any value other than 00, 01, 02.
3 (03H)	Illegal data value (Value out of the setting range) For function code 08 (08H): Data is less than 1, or has exceeded 100. For function code 43 (2BH): Read Device ID code is any value other than 01, 04.

#### (3) Data

Data differs depending on the function code.

For the Function code 08 (08H), a request message from the master side is composed of 'Sub-function code 2 Bytes (0000H)' and 'Data n x 2 Bytes'. [n: Amount of data (Max. 100)]

In normal status, a response message from the slave side is the same as the request message.

Function code	1 Byte	08H
Sub-function code	1 Byte	0000H fixed
Data	n x 2 Bytes	Random value (Max. 100)

For Function code 43 (2BH), the request message from the master side is composed of Sub-function code 14 (0EH), Read Device ID code and Object ID.

Function code	1 Byte	2BH	
Sub-function code (MEI type)	1 Byte	0EH	
Read Device ID code (Corresponds to Basic category)	1 Byte	01H/04H	
Object ID	1 Byte	00	Vendor name SHINKO TECHNOS CO., LTD.
		01	Product code (model) (e.g.) JIR-301-M
		02	Version number (D, T, MP) (e.g.) Dxx-xxxx-xx, MPxxxx-xx

Response message from the slave is composed of Sub-function code 14 (0EH) (for request), Read Device ID code and Object ID.

Function code	1 Byte	2BH	
Sub-function code (MEI type)	1 Byte	0EH	
Data	Read Device ID code	1 Byte	01H/04H
	Conformity level	1 Byte	01H/81H
	More Follows	1 Byte	00H/FFH
	Next Object ID	1 Byte	Object ID number
	Number of Objects	1 Byte	
	List of Object ID	1 Byte	
	List of Object length	1 Byte	
	List of Object value	Object length	

For the response message (negative acknowledgement), an exception code is set and returned.

Function code	1 Byte	ABH
Exception code	1 Byte	01H/02H/03H

#### (4) Error check:

16-bit data to detect communication errors.

Refer to Sections "6.3 Message Configuration (4) Error Check (p.13)".

### 6.5.2 Message Example

Message examples in RTU mode are shown below.

Numerals written below the command represent the number of characters.

#### (1) Echo back Slave address 1, Request message

- A request message from the master [Test data 200 (00C8H), 60 (003CH), 10 (000AH)]

3.5 idle characters	Slave address (01H)	Function code (08H)	Sub-function code (0000H)	Data (00C8003C000AH)	Error check CRC-16 (E7D9H)	3.5 idle characters
	1	1	2	n x 2	2	

- Response message from the slave in normal status (Echoes back the same message.)

3.5 idle characters	Slave address (01H)	Function code (08H)	Sub-function code (0000H)	Data (00C8003C000AH)	Error check CRC-16 (E7D9H)	3.5 idle characters
	1	1	2	n x 2	2	

**(2) Read Slave address 1, Device identification information (Vendor name)**

- A request message from the master

3.5 idle characters	Slave address (01H)	Function code (2BH)	Sub-function code (0EH)	Data (0400H)	Error check CRC-16 (7327H)	3.5 idle characters
	1	1	1	2	2	

- Response message from the slave in normal status (SHINKO TECHNOS CO., LTD.)

3.5 idle characters	Slave address (01H)	Function code (2BH)	Sub-function code (0EH)	
	1	1	1	

Data
(048100000100185348494E4B4F20544543484E4F5320434F2E2C204C54442EH)
31

Error check CRC-16 (1C54H)	3.5 idle characters
2	

Data in the response message is as follows:

Data	Read Device ID code	1 Byte	04H
	Conformity level	1 Byte	81H
	More Follows	1 Byte	00H
	Next Object ID	1 Byte	00H
	Number of Objects	1 Byte	01H
	List of Object ID	1 Byte	00H
	List of Object length	1 Byte	24(18H)
	List of Object value	Object length	S(53H)
			H(48H)
			I(49H)
			N(4EH)
			K(4BH)
			O(4FH)
			(20H)
			T(54H)
			E(45H)
			C(43H)
			H(48H)
			N(4EH)
			O(4FH)
			S(53H)
			(20H)
			C(43H)
			O(4FH)
			.(2EH)
			.(2CH)
		(20H)	
		L(4CH)	
		T(54H)	
		D(44H)	
		.(2EH)	

### (3) Read Slave address 1, Device identification information (Product code)

- A request message from the master

3.5 idle characters	Slave address (01H)	Function code (2BH)	Sub-function code (0EH)	Data (0401H)	Error check CRC-16 (B2E7H)	3.5 idle characters
	1	1	1	2	2	

- Response message from the slave in normal status (JIR-301-M)

3.5 idle characters	Slave address (01H)	Function code (2BH)	Sub-function code (0EH)			
	1	1	1			
	Data (048100000101094A49522D3330312D4DH)				Error check CRC-16 (17CBH)	3.5 idle characters
	18				2	

Data in the response message is as follows:

Data	Read Device ID code	1 Byte	04H
	Conformity level	1 Byte	81H
	More Follows	1 Byte	00H
	Next Object ID	1 Byte	00H
	Number of Objects	1 Byte	01H
	List of Object ID	1 Byte	01H
	List of Object length	1 Byte	9(09H)
	List of Object value	Object length	J(4AH)
			I(49H)
			R(52H)
			-(2DH)
			3(33H)
			0(30H)
			1(31H)
			-(2DH)
		M(4DH)	

- Response message from the slave in exception (error) status [when Sub-function code (MEI type) is incorrect]

The function code MSB is set to 1 for the response message in exception (error) status, and ABH is returned.

Exception code 01H (Non-existent function) is returned (error).

3.5 idle characters	Slave address (01H)	Function code (ABH)	Exception code (01H)	Error check CRC-16 (9EF0H)	3.5 idle characters
	1	1	1	2	

# 7. Communication Command Table

## 7.1 Command of Shinko Protocol/ MODBUS ASCII Mode/ MODBUS RTU Mode

### 7.1.1 A Single Piece of Data (Read/Write Command)

Shinko Command Type	MODBUS Function Code	Data Item		Data
20H/50H	03H/06H	0001H	A1 value	Set value (Decimal point ignored.)
20H/50H	03H/06H	0002H	A2 value	Set value (Decimal point ignored.)
20H/50H	03H/06H	0003H	A3 value	Set value (Decimal point ignored.)
20H/50H	03H/06H	0004H	Set value lock	0000H: Unlock 0001H: Lock 1 0002H: Lock 2 0003H: Lock 3
20H/50H	03H/06H	0005H	Sensor correction	Set value (Decimal point ignored.)
20H/50H	03H/06H	0006H	Scaling high limit	Set value
20H/50H	03H/06H	0007H	Scaling low limit	Set value
20H/50H	03H/06H	0008H	Decimal point place	0000H: XXXX (No decimal point) 0001H: XXX.X (1 digit after decimal point) 0002H: XX.XX (2 digits after decimal point) 0003H: X.XXX (3 digits after decimal point)
20H/50H	03H/06H	0009H	PV filter time constant	Set value (Decimal point ignored.)
20H/50H	03H/06H	000AH	A1 hysteresis	Set value (Decimal point ignored.)
20H/50H	03H/06H	000BH	A2 hysteresis	Set value (Decimal point ignored.)
20H/50H	03H/06H	000CH	A3 hysteresis	Set value (Decimal point ignored.)
20H/50H	03H/06H	000DH	A1 type	0000H: No alarm action 0001H: High limit alarm 0002H: Low limit alarm 0003H: High limit with standby alarm 0004H: Low limit with standby alarm
20H/50H	03H/06H	000EH	A2 type	0000H: No alarm action 0001H: High limit alarm 0002H: Low limit alarm 0003H: High limit with standby alarm 0004H: Low limit with standby alarm
20H/50H	03H/06H	000FH	A3 type	0000H: No alarm action 0001H: High limit alarm 0002H: Low limit alarm 0003H: High limit with standby alarm 0004H: Low limit with standby alarm 0005H: High/Low limit range alarm
20H/50H	03H/06H	0010H	Transmission output 1 high limit	Set value
20H/50H	03H/06H	0011H	Transmission output 1 low limit	Set value
20H/50H	03H/06H	0012H	A1 Energized/De-energized	0000H: Energized 0001H: De-energized
20H/50H	03H/06H	0013H	A2 Energized/De-energized	0000H: Energized 0001H: De-energized
20H/50H	03H/06H	0014H	A3 Energized/De-energized	0000H: Energized 0001H: De-energized
20H/50H	03H/06H	0015H	A1 delay time	Set value
20H/50H	03H/06H	0016H	A2 delay time	Set value
20H/50H	03H/06H	0017H	A3 delay time	Set value



Shinko Command Type	MODBUS Function Code	Data Item		Data
20H/50H	03H/06H	0019H	Input type	0000H: K (-200 to 1370°C) 0001H: K (-200.0 to 400.0°C) 0002H: J (-200 to 1000°C) 0003H: R (0 to 1760°C) 0004H: S (0 to 1760°C) 0005H: B (0 to 1820°C) 0006H: E (-200 to 800°C) 0007H: T (-200.0 to 400.0°C) 0008H: N (-200 to 1300°C) 0009H: PL-Ⅱ (0 to 1390°C) 000AH: C (W/Re5-26)(0 to 2315°C) 000BH: Pt100 (-200.0 to 850.0°C) 000CH: JPt100 (-200.0 to 500.0°C) 000DH: Pt100 (-200 to 850°C) 000EH: JPt100 (-200 to 500°C) 000FH: K (-320 to 2500°F) 0010H: K (-200.0 to 750.0°F) 0011H: J (-320 to 1800°F) 0012H: R (0 to 3200°F) 0013H: S (0 to 3200°F) 0014H: B (0 to 3300°F) 0015H: E (-320 to 1500°F) 0016H: T (-200.0 to 750.0°F) 0017H: N (-320 to 2300°F) 0018H: PL-Ⅱ (0 to 2500°F) 0019H: C (W/Re5-26)(0 to 4200°F) 001AH: Pt100 (-200.0 to 1000.0°F) 001BH: JPt100 (-200.0 to 900.0°F) 001CH: Pt100 (-300 to 1500°F) 001DH: JPt100 (-300 to 900°F) 001EH: 4 to 20 mA DC (-2000 to 10000) (Externally mounted shunt resistor) 001FH: 0 to 20 mA DC (-2000 to 10000) (Externally mounted shunt resistor) 0020H: 0 to 1 V DC (-2000 to 10000) 0021H: 0 to 5 V DC (-2000 to 10000) 0022H: 1 to 5 V DC (-2000 to 10000) 0023H: 0 to 10 V DC (-2000 to 10000) 0024H: 4 to 20 mA DC (-2000 to 10000) (Built-in shunt resistor) 0025H: 0 to 20 mA DC (-2000 to 10000) (Built-in shunt resistor)

### 7.1.2 A Single Piece of Data (Write Command)

Shinko Command Type	MODBUS Function Code	Data Item		Data
50H	06H	0070H	Key operation change flag clearing	0000H: No action 0001H: Clear key operation change flag

### 7.1.3 A Single Piece of Data (Read Command)

Shinko Command Type	MODBUS Function Code	Data Item		Data
20H	03H	0080H	PV	PV (Decimal point ignored.)
20H	03H	0081H	Status flag	0000 0000 0000 0000 $2^{15}$ to $2^0$ $2^0$ digit: A1 output 0: OFF  1: ON $2^1$ digit: A2 output 0: OFF  1: ON $2^2$ digit: A3 output 0: OFF  1: ON $2^3$ digit: Overscale 0: OFF  1: ON $2^4$ digit: Underscale 0: OFF  1: ON $2^5 - 2^{14}$ digit: Not used (Always 0) $2^{15}$ digit: Change in key operation 0: No    1: Yes
20H	03H	00A1H	Unit specification flag	0000 0000 0000 0000 $2^{15}$ to $2^0$ $2^0$ digit: A1 function Available/Unavailable 0: Unavailable  1: Available $2^1$ digit: A2 function Available/Unavailable 0: Unavailable  1: Available $2^2$ digit: A3 function Available/Unavailable 0: Unavailable  1: Available $2^3$ digit: Communication function Available/Unavailable 0: Unavailable  1: Available $2^4$ digit: Transmission output 1 Available/Unavailable 0: Unavailable  1: Available $2^5 - 2^{15}$ digit: Not used (Always 0)

**7.2 Command of Shinko Protocol (Block Read/Write available), MODBUS ASCII Mode (Block Read/Write available), and MODBUS RTU Mode (Block Read/Write available)**

**7.2.1 A Single/Multiple Piece(s) of Data (Read/Write Command)**

Shinko Command Type	MODBUS Function Code	Data Item		Data
20H/24H/50H/54H	03H/06H/10H	0001H	Input type	0000H: K [-200 to 1370°C] 0001H: K [-200.0 to 400.0°C] 0002H: J [-200 to 1000°C] 0003H: R [0 to 1760°C] 0004H: S [0 to 1760°C] 0005H: B [0 to 1820°C] 0006H: E [-200 to 800°C] 0007H: T [-200.0 to 400.0°C] 0008H: N [-200 to 1300°C] 0009H: PL-Ⅱ [0 to 1390°C] 000AH: C(W/Re5-26) [0 to 2315°C] 000BH: Pt100 [-200.0 to 850.0°C] 000CH: JPt100 [-200.0 to 500.0°C] 000DH: Pt100 [-200 to 850°C] 000EH: JPt100 [-200 to 500°C] 000FH: K [-320 to 2500°F] 0010H: K [-200.0 to 750.0°F] 0011H: J [-320 to 1800°F] 0012H: R [0 to 3200°F] 0013H: S [0 to 3200°F] 0014H: B [0 to 3300°F] 0015H: E [-320 to 1500°F] 0016H: T [-200.0 to 750.0°F] 0017H: N [-320 to 2300°F] 0018H: PL-Ⅱ [0 to 2500°F] 0019H: C (W/Re5-26)[0 to 4200°F] 001AH: Pt100 [-200.0 to 1000.0°F] 001BH: JPt100 [-200.0 to 900.0°F] 001CH: Pt100 [-300 to 1500°F] 001DH: JPt100 [-300 to 900°F] 001EH: 4 to 20 mA DC [-2000 to 10000] (Externally mounted shunt resistor) 001FH: 0 to 20 mA DC [-2000 to 10000] (Externally mounted shunt resistor) 0020H: 0 to 1 V DC [-2000 to 10000] 0021H: 0 to 5 V DC [-2000 to 10000] 0022H: 1 to 5 V DC [-2000 to 10000] 0023H: 0 to 10 V DC [-2000 to 10000] 0024H: 4 to 20 mA DC [-2000 to 10000] (Built-in shunt resistor) 0025H: 0 to 20 mA DC [-2000 to 10000] (Built-in shunt resistor)
20H/24H/50H/54H	03H/06H/10H	0002H	Scaling high limit	Set value
20H/24H/50H/54H	03H/06H/10H	0003H	Scaling low limit	Set value

Shinko Command Type	MODBUS Function Code	Data Item		Data
20H/24H/50H/54H	03H/06H/10H	0004H	Decimal point place	0000H: XXXX (No decimal point) 0001H: XXX.X (1 digit after decimal point) 0002H: XX.XX (2 digits after decimal point) 0003H: X.XXX (3 digits after decimal point)
20H/24H/50H/54H	03H/06H/10H	0005H	A1 type	0000H: No alarm action 0001H: High limit alarm 0002H: Low limit alarm 0003H: High limit with standby alarm 0004H: Low limit with standby alarm
20H/24H/50H/54H	03H/06H/10H	0006H	A2 type	0000H: No alarm action 0001H: High limit alarm 0002H: Low limit alarm 0003H: High limit with standby alarm 0004H: Low limit with standby alarm
20H/24H/50H/54H	03H/06H/10H	0007H	A3 type	0000H: No alarm action 0001H: High limit alarm 0002H: Low limit alarm 0003H: High limit with standby alarm 0004H: Low limit with standby alarm 0005H: High/Low limit range alarm
20H/24H/50H/54H	03H/06H/10H	0008H	A4 type	0000H: No alarm action 0001H: High limit alarm 0002H: Low limit alarm 0003H: High limit with standby alarm 0004H: Low limit with standby alarm 0005H: High/Low limit range alarm
20H/24H/50H/54H	03H/06H/10H	0009H	A1 value	Set value (Decimal point ignored.)
20H/24H/50H/54H	03H/06H/10H	000AH	A2 value	Set value (Decimal point ignored.)
20H/24H/50H/54H	03H/06H/10H	000BH	A3 value	Set value (Decimal point ignored.)
20H/24H/50H/54H	03H/06H/10H	000CH	A4 value	Set value (Decimal point ignored.)
20H/24H/50H/54H	03H/06H/10H	000DH	A4 high limit value	Set value (Decimal point ignored.)
20H/24H/50H/54H	03H/06H/10H	000EH	A1 hysteresis	Set value (Decimal point ignored.)
20H/24H/50H/54H	03H/06H/10H	000FH	A2 hysteresis	Set value (Decimal point ignored.)
20H/24H/50H/54H	03H/06H/10H	0010H	A3 hysteresis	Set value (Decimal point ignored.)
20H/24H/50H/54H	03H/06H/10H	0011H	A4 hysteresis	Set value (Decimal point ignored.)
20H/24H/50H/54H	03H/06H/10H	0012H	A1 Energized/ De-energized	0000H: Energized 0001H: De-energized
20H/24H/50H/54H	03H/06H/10H	0013H	A2 Energized/ De-energized	0000H: Energized 0001H: De-energized
20H/24H/50H/54H	03H/06H/10H	0014H	A3 Energized/ De-energized	0000H: Energized 0001H: De-energized
20H/24H/50H/54H	03H/06H/10H	0015H	A4 Energized/ De-energized	0000H: Energized 0001H: De-energized
20H/24H/50H/54H	03H/06H/10H	0016H	A1 delay time	Set value
20H/24H/50H/54H	03H/06H/10H	0017H	A2 delay time	Set value
20H/24H/50H/54H	03H/06H/10H	0018H	A3 delay time	Set value
20H/24H/50H/54H	03H/06H/10H	0019H	A4 delay time	Set value

Shinko Command Type	MODBUS Function Code	Data Item		Data
20H/24H/50H/54H	03H/06H/10H	001AH	A1 HOLD function	0000H: Disabled 0001H: Enabled
20H/24H/50H/54H	03H/06H/10H	001BH	A2 HOLD function	0000H: Disabled 0001H: Enabled
20H/24H/50H/54H	03H/06H/10H	001CH	A3 HOLD function	0000H: Disabled 0001H: Enabled
20H/24H/50H/54H	03H/06H/10H	001DH	A4 HOLD function	0000H: Disabled 0001H: Enabled
20H/24H/50H/54H	03H/06H/10H	001EH	Set value lock	0000H: Unlock 0001H: Lock 1 0002H: Lock 2 0003H: Lock 3
20H/24H/50H/54H	03H/06H/10H	001FH	Sensor correction coefficient	Set value (Decimal point ignored.)
20H/24H/50H/54H	03H/06H/10H	0020H	Sensor correction	Set value (Decimal point ignored.)
20H/24H/50H/54H	03H/06H/10H	0021H	PV filter time constant	Set value (Decimal point ignored.)
20H/24H/50H/54H	03H/06H/10H	0022H	Transmission output 1 high limit	Set value (Decimal point ignored.)
20H/24H/50H/54H	03H/06H/10H	0023H	Transmission output 1 low limit	Set value (Decimal point ignored.)
20H/24H/50H/54H	03H/06H/10H	0024H	Transmission output 2 high limit	Set value (Decimal point ignored.)
20H/24H/50H/54H	03H/06H/10H	0025H	Transmission output 2 low limit	Set value (Decimal point ignored.)
20H/24H/50H/54H	03H/06H/10H	0026H	Square root function	0000H: Disabled 0001H: Enabled
20H/24H/50H/54H	03H/06H/10H	0027H	Low level cutoff	Set value (Decimal point ignored.)
20H/24H/50H/54H	03H/06H/10H	0028H	Reserved (*1)	
20H/24H/50H/54H	03H/06H/10H	0029H	Reserved (*1)	
		:	:	
20H/24H/50H/54H	03H/06H/10H	00FEH	Reserved (*1)	

### 7.2.2 A Single Piece of Data (Write Command) (\*2)

Shinko Command Type	MODBUS Function Code	Data Item		Data
50H/54H	06H/10H	00FFH	Key operation change flag clearing	0000H: No action 0001H: Clear key operation change flag

### 7.2.3 A Single/Multiple Piece(s) of Data (Read Command) (\*3)

Shinko Command Type	MODBUS Function Code	Data Item		Data
20H/24H	03H/04H	0100H	PV	PV (Decimal point ignored.)
20H/24H	03H/04H	0101H	Transmission output 1 output amount	Transmission output 1 output amount, (Decimal point ignored.)
20H/24H	03H/04H	0102H	Transmission output 2 output amount	Transmission output 2 output amount, (Decimal point ignored.)
20H/24H	03H/04H	0103H	Reserved (*1)	
		:	:	
20H/24H	03H/04H	010BH	Reserved (*1)	
20H/24H	03H/04H	010CH	Key operation change item	Data item changed by key operation change item
20H/24H	03H/04H	010DH	Status flag 1	0000 0000 0000 0000 $2^{15}$ to $2^0$ $2^0$ digit: A1 output 0: OFF 1: ON $2^1$ digit: A2 output 0: OFF 1: ON $2^2$ digit: A3 output 0: OFF 1: ON $2^3$ digit: A4 output 0: OFF 1: ON $2^4$ digit: Overscale 0: OFF 1: ON $2^5$ digit: Underscale 0: OFF 1: ON $2^6$ to $2^{14}$ digit: Not used (Always 0) $2^{15}$ digit: Change in key operation 0: No 1: Yes
20H/24H	03H/04H	010EH	Status flag 2	0000 0000 0000 0000 $2^{15}$ to $2^0$ $2^0$ to $2^5$ digit: Not used (Always 0) $2^6$ digit: Operation status 0: PV/SV Display Mode 1: Setting mode $2^7$ digit: Warm-up 0: Finished 1: During warm-up $2^8$ to $2^{15}$ digit: Not used (Always 0)
20H/24H	03H/04H	010FH	Reserved (*1)	
20H/24H	03H/04H	0110H	Reserved (*1)	
20H/24H	03H/04H	0111H	Software version	Software version (Decimal point ignored.)
20H/24H	03H/04H	0112H	Unit specification flag	0000 0000 0000 0000 $2^{15}$ to $2^0$ $2^0$ digit: A1 function Available/Unavailable 0: Unavailable 1: Available $2^1$ digit: A2 function Available/Unavailable 0: Unavailable 1: Available $2^2$ digit: A3 function Available/Unavailable 0: Unavailable 1: Available

Shinko Command Type	MODBUS Function Code	Data Item		Data
				2 <sup>3</sup> digit: A4 function Available/Unavailable 0: Unavailable 1: Available 2 <sup>4</sup> digit: Communication function Available/Unavailable 0: Unavailable 1: Available 2 <sup>5</sup> digit: Transmission output 1 Available/Unavailable 0: Unavailable 1: Available 2 <sup>6</sup> digit: Transmission output 2 Available/Unavailable 0: Unavailable 1: Available 2 <sup>7</sup> digit: Insulated power output (P24) Available/Unavailable 0: Unavailable 1: Available 2 <sup>8</sup> digit: Insulated power output (P5) Available/Unavailable 0: Unavailable 1: Available 2 <sup>9</sup> digit: Power for 2-wire transmitter Available/Unavailable 0: Unavailable 1: Available 2 <sup>10</sup> to 2 <sup>15</sup> digit: Not used (Always 0)
20H/24H	03H/04H	0113H	Reserved (*1)	
		:	:	
20H/24H	03H/04H	01FFH	Reserved (*1)	
		0200H	Not used (*4)	
		:	:	
		FFFFH	Not used (*4)	

(\*1) For 'Reserved' items:

If a single/multiple piece(s) of data is/are read, acknowledgement will be returned (but data is 0).

If a single/multiple piece(s) of data is/are written, data will be discarded, and acknowledgement will be returned.

(\*2) If a single piece of data (*Write command*) is read, acknowledgement will be returned (but data is 0)

(\*3) If a single/multiple piece(s) of data (*Read command*) is written, data will be discarded, and acknowledgement will be returned.

(\*4) For 'Not used' items, if a single/multiple piece(s) of data is/are read or written, Error code 1 (31H, Shinko protocol) or Exception code 2 (02H, MODBUS protocol) will be returned.

## 7.3 Data

### 7.3.1 Notes about Write/Read Command

- The data (set value, decimal) is converted to hexadecimal figures.  
A negative number is represented by 2's complement.
- When connecting multiple slaves, the address (instrument number) must not be duplicated.
- Do not use undefined Data items. If they are used, negative acknowledgement will be returned or a random value will be written or read, resulting in malfunction.
- MODBUS protocol uses Holding Register addresses. The Holding Register addresses are created as follows. A Shinko command data item is converted to decimal number, and the offset of 40001 is added. The result is the Holding Register address.

Using Data item 0001H (A1 value or input type) as an example:

Data item in the sending message is 0001H, however, MODBUS protocol Holding Register address is 40002 (1 + 40001).

### 7.3.2 Write Command

- Setting range of each item is the same as that of keypad operation.
- When the data (set value) has a decimal point, a whole number (hexadecimal) without a decimal point is used.
- Writings via software communication are possible while in Set value lock status.  
When 0003H (Lock 3) is selected at Data item 0004H or 001EH (Set value lock), the written data will not be saved in the non-volatile memory. Therefore, they return to their previous value after power is turned off.
- If any alarm type is changed at Data item [000DH, 000EH, 000FH or 0005H, 0006H, 0007H, 0008H], their alarm value (0001H, 0002H, 0003H or 0009H, 000AH, 000BH, 000CH) will default to 0 (zero). Alarm output status will also be initialized.
- If 'Power for 2-wire transmitter' (DSB option) is ordered, and if an input type is changed at Data item [0019H or 0001H], acknowledgement will be returned, and the setting data will be discarded.  
If the input type is read, the default value (0024H) will be returned as data.
- Even if options are not ordered, writing via software communication will be possible. However, their command contents will not function.
- Communication parameters such as Instrument Number, Communication Speed of the slave cannot be written by software communication. They can only be set via the keypad. See p.3.
- When Write is executed using the Global address [95 (7FH), Shinko protocol] command or Broadcast address [(00H) MODBUS protocol] command, the command is sent to all the connected slaves. However, a response is not returned.
- Up to 1,000,000 (one million) entries can be stored in non-volatile IC memory.  
If the number of settings exceeds the limit, the data will not be saved. So, frequent transmission via software communication is not recommended. (If a value written via software communication is the same as the value before the setting, the value will not be written in non-volatile IC memory.)

### 7.3.3 Read Command

- When the data (set value) has a decimal point, a whole number (hexadecimal) without a decimal point is used for a response.



## 7.4 Negative Acknowledgement

The slave will return Error code 1 (31H, Shinko protocol) or Exception code 2 (02H, MODBUS protocol) in the following case.

- When non-existent data item is read or written.

The slave will return Error code 3 (33H, Shinko protocol) or Exception code 3 (03H, MODBUS protocol) in the following case.

- When a value out of the setting range is written.

The slave will return Error code 5 (35H, Shinko protocol) or Exception code 18 (12H, MODBUS protocol) in the following case.

- During setting mode by keypad operation

## 7.5 Notes about Programming Monitoring Software

### 7.5.1 How to Speed up the Scan Time

When monitoring multiple units of JIR-301-M, set the program so that the requisite minimum pieces of data such as PV (0080H or 0100H), Status flag (0081H), Status flag 1 (010DH), etc. can be read. For other data, set the program so that they can be read only when their set value has changed. This will speed up the scan time.

### 7.5.2 How to Read the Set Value Changes Made by Front Keypad Operation

If any set value is changed by the keypad operation, the JIR-301-M sets [Status flag (0081H) or Status flag 1 (010DH) 2<sup>15</sup>: Change in key operation] to [Yes (1)].

There are 2 methods of reading the set value changes made by the front keypad.

#### Reading Method 1

(1) On the software side, check that [Status flag (0081H) or Status flag 1 (010DH) 2<sup>15</sup>: Change in key operation] has been set to [Yes (1)], then read all set values.

(2) Clear the [Status flag (0081H) 2<sup>15</sup>: Change in key operation], by writing the [Key operation change flag clearing (0070H or 00FFH)] to [Clear key operation change flag (0001H)].

If [Key operation change flag clearing (0070H or 00FFH)] is written to [Clear key operation change flag (0001H)] during setting mode of the JIR-301-M, Error code 5 (35H, Shinko protocol) or Exception Code 18 (12H, MODBUS protocol) will be returned as a negative acknowledgement. And [Status flag (0081H) or Status flag 1 (010DH) 2<sup>15</sup>: Change in key operation] cannot be cleared.

Set a program so that all set values can be read when a negative acknowledgement is returned.

(3) Read all set values again after acknowledgement is returned.

#### Reading Method 2

(1) On the software side, check that [Status flag (0081H) or Status flag 1 (010DH) 2<sup>15</sup>: Change in key operation] has been set to [Yes (1)], then write the [Key operation change flag clearing (0070H or 00FFH)] to [Clear key operation change flag (0001H)].

(2) Set the program depending on the acknowledgement or negative acknowledgement as follows:

When acknowledgement is returned;

Consider it as settings completed, and read all set values.

When Error code 5 (35H, Shinko protocol) or Exception code 18 (12H, MODBUS protocol) is returned as a negative acknowledgement;

Consider it as still in setting mode, and read the requisite minimum pieces of data such as PV (0080H or 0100H), Status flag (0081H), Status flag 1 (010DH). then return to step (1).

Thus, programs which do not affect the scan time can be created using the methods described above, even if set values on the monitoring software will not be updated until settings are complete.

### 7.5.3 Note when Sending All Set Values at One Time

- When changing alarm types in [000DH, 000EH, 000FH or 0005H, 0006H, 0007H, 0008H], the alarm value (0001H, 0002H, 0003H or 0009H, 000AH, 000BH, 000CH) will default to "0". Alarm output status will also be initialized.

First, send the alarm type, then send the alarm value.

- When changing input types in [Input type (0019H or 0001H)], the set values such as Scaling high limit, Scaling low limit or alarm value, etc. will be initialized.

First, send the input type, then send other set values.

### 7.6 When Communicating with a PLC

To communicate with a PLC, use a Shinko PLC interface unit SIF-600. No programming is needed for connection. However, Shinko protocol 24H (Multiple pieces of data *Read command*) and 54H (Multiple pieces of data *Write command*) are not available for the SIF-600.

#### PLCs Corresponding to SIF-600, its manufacturer and host link units:

PLC Manufacturer	PLC Model	Host Link Unit
Mitsubishi Electric Corp.	MELSEC	AJ71UC24, A1SJ71UC24-R2/R4/PRF
	Q series, QnA series (*)	A1SJ71C24-R2/R4/PRF, QJ71C24
	MELSEC FX series (*)	
Omron Corp.	SYSMAC CJ series	CS1W-SCU21-V1 CJ1W-SCU21, CJ1W-SCU41
Keyence Corp.	KV	KV-L20V
Yokogawa Electric Corp.	FA-M3	F3LC11-2N, F3LC11-1F, F3LC12-1F
Fuji Electric Co., Ltd.	MICREX-SX series	NP1L-RS1, NP1L-RS2, NP1L-RS3, NP1L-RS4

(\*) Models with compatible QR/QW communication commands (MC protocol 1C Format 4).

## 8. Specifications

Cable length: 1.2 km (Max.)  
 Cable resistance: Within 50  $\Omega$  (Terminators are not necessary, but if used, use 120  $\Omega$  minimum on both sides.)

Communication line: EIA RS-485

Communication method: Half-duplex communication

Communication speed: 2400, 4800, 9600, 19200, 38400 bps (Selectable by keypad)  
 (Factory default: 9600 bps)

Synchronization method: Start-stop synchronization

Code form: ASCII, binary

Communication protocol: Shinko protocol, MODBUS ASCII, MODBUS RTU  
 In addition, each protocol above is available with Block Read/Write. (Selectable by keypad)  
 (Factory default: Shinko protocol)

Data format:

Communication Protocol	Shinko Protocol	MODBUS ASCII	MODBUS RTU
Start bit	1	1	1
Data bit (*1)	7	7	8
Parity	Even	Selection [Even] (*2)	Selection [No parity] (*2)
Stop bit	1	Selection [1] (*2)	Selection [1] (*2)

(\*1) Data bit is automatically selected upon selecting the communication protocol.

(\*2) [ ]: Basic set value

Number of connectable units: Maximum 31 units to 1 host computer

Error correction: Command request repeat system

Error detection: Parity, checksum (Shinko protocol), LRC (MODBUS ASCII), CRC-16 (MODBUS RTU)

## 9. Troubleshooting

Check that power is being supplied to the master and slave that customers use. If communication failure still occurs, check the following.

- **Problem: Communication failure**

Check if any of the following have occurred
Communication cable is not securely connected, or is disconnected/defective.
Incorrect wiring of the communication cable and/or connector
Communication speed of the slave does not match that of the master.
The data bit, parity and stop bit of the master do not correspond to those of the slave.
The instrument number (address) of the slave does not correspond to that of the command.
The instrument numbers (addresses) are duplicated in multiple slaves.
Make sure that the program is appropriate for the transmission timing.

- **Problem: Although communication is occurring, the response is negative acknowledgement.**

Check if any of the following have occurred
A non-existent command code has been sent.
The Write command data exceeds the setting range of the slave.
The JIR-301-M cannot be written when functions such as AT are performing.
The JIR-301-M is in the front keypad operation setting mode.

For further inquiries, please contact our main office or dealers.

### SHINKO TECHNOS CO., LTD. OVERSEAS DIVISION

Head Office: 2-5-1, Senbahigashi, Minoo, Osaka, 562-0035, Japan

[URL] <https://shinko-technos.co.jp/e/>

[E-mail] [overseas@shinko-technos.co.jp](mailto:overseas@shinko-technos.co.jp)

Tel: +81-72-727-6100

Fax: +81-72-727-7006