

**Shinko** SHINKO TECHNOS CO., LTD. Head office: 2-5-1, Senbahigashi, Minoo, Osaka, 562-0035, Japan  
 TEL: +81-72-727-6100 FAX: +81-72-727-7006 URL: <http://www.shinko-technos.co.jp/e/> E-mail: [overseas@shinko-technos.co.jp](mailto:overseas@shinko-technos.co.jp)

For detailed usage, refer to the Instruction Manual for the PCA1. Please download the full Instruction Manual from the Shinko Technos website.  
<http://shinko-technos.co.jp/e/> → Support & Downloads → Downloads → Manuals

Thank you for purchasing our PCA1, Programmable Controller. This manual contains instructions for the mounting, functions, operations and notes when operating the PCA1. To ensure safe and correct use, thoroughly read and understand this manual before using this instrument. To prevent accidents arising from the misuse of this instrument, please ensure the operator receives this manual.

## Safety Precautions (Be sure to read these precautions before using our products.)

The safety precautions are classified into 2 categories: "Warning" and "Caution".

⚠ Warning: Procedures which may lead to dangerous conditions and cause death or serious injury, if not carried out properly.

⚠ Caution: Procedures which may lead to dangerous conditions and cause superficial to medium injury or physical damage or may degrade or damage the product, if not carried out properly.

### ⚠ Warning

- To prevent an electrical shock or fire, only Shinko or other qualified service personnel may handle the inner assembly.
- To prevent an electrical shock, fire or damage to the instrument, parts replacement may only be undertaken by Shinko or other qualified service personnel.

### ⚠ SAFETY PRECAUTIONS

- To ensure safe and correct use, thoroughly read and understand this manual before using this instrument.
- This instrument is intended to be used for industrial machinery, machine tools and measuring equipment. Verify correct usage after purpose-of-use consultation with our agency or main office. (Never use this instrument for medical purposes with which human lives are involved.)
- External protection devices such as protective equipment against excessive temperature rise, etc. must be installed, as malfunction of this product could result in serious damage to the system or injury to personnel. Proper periodic maintenance is also required.
- This instrument must be used under the conditions and environment described in this manual. Shinko Technos Co., Ltd. does not accept liability for any injury, loss of life or damage occurring due to the instrument being used under conditions not otherwise stated in this manual.

### ⚠ Caution for Mounting

This instrument is intended to be used under the following environmental conditions (IEC61010-1): Overvoltage category II, Pollution degree 2  
 Ensure the mounting location corresponds to the following conditions:

- A minimum of dust, and an absence of corrosive gases
- No flammable, explosive gases
- No mechanical vibrations or shocks
- No exposure to direct sunlight, an ambient temperature of 0 to 50°C (32 to 122°F) (No icing)
- An ambient non-condensing humidity of 35 to 85 %RH (Non-condensing)
- No large capacity electromagnetic switches or cables through which large current is flowing
- No water, oil or chemicals or the vapors of these substances can come into direct contact with the unit
- Take note that the ambient temperature of this unit – not the ambient temperature of the control panel – must not exceed 50°C (122°F) if mounted through the face of a control panel, otherwise the life of electronic components (especially electrolytic capacitors) may be shortened.

### ⚠ Caution with Respect to Export Trade Control Ordinance

To avoid this instrument from being used as a component in, or as being utilized in the manufacture of weapons of mass destruction (i.e. military applications, military equipment, etc.), please investigate the end users and the final use of this instrument. In the case of resale, ensure that this instrument is not illegally exported.

## Specifications

Power supply voltage	100 to 240 V AC 50/60 Hz Allowable fluctuation: 85 to 264 V AC 24 V AC/DC 50/60 Hz Allowable fluctuation: 20 to 28 V AC/DC
Power consumption	Approx. 16 VA
Ambient temperature	0 to 50°C (No icing, non-condensing)
Ambient humidity	35 to 85 %RH (Non-condensing)
Base accuracy	Thermocouple: Within $\pm 0.2\%$ of each input span $\pm 1$ digit However, R, S inputs, 0 to 200°C (32 to 392°F): Within $\pm 6^\circ\text{C}$ (12°F) B input, 0 to 300°C (32 to 572°F): Accuracy is not guaranteed. K, J, E, T, N inputs, Less than 0°C (32°F): Within $\pm 0.4\%$ of input span $\pm 1$ digit RTD: Within $\pm 0.1\%$ of each input span $\pm 1$ digit Direct current, voltage inputs: Within $\pm 0.2\%$ of each input span $\pm 1$ digit
Cold junction compensation accuracy	Within $\pm 1^\circ\text{C}$ at 0 to 50°C
Input sampling period	125 ms
Time indication accuracy	$\pm 0.1\%$ of setting time
Weight	Approx. 460 g
Accessories	Mounting brackets: 1 set Instruction manual excerpt: 1 copy
Event input	Input points: Max. 4 points (When C or C5 option is ordered: 2 points) Circuit current when closed: Approx. 16 mA

Control output OUT1	Relay contact 1a 1b: Control capacity: 3 A 250 V AC (resistive load) 1 A 250 V AC (inductive load $\cos\phi=0.4$ ) Electrical life: 100,000 cycles Non-contact voltage (For SSR drive): 12 V DC $\pm 15\%$ Max. 40 mA (short circuit protected) Direct current: 4 to 20 mA DC (Resolution: 12000) Load resistance: Max. 600 $\Omega$
Event output (EV1 to EV4)	Relay contact 1a: Control capacity 3 A 250 V AC (resistive load) 1 A 250 V AC (inductive load $\cos\phi=0.4$ ) Electrical life: 100,000 cycles One of EV3, EV4 terminals is a common terminal.
Time signal output (TS option)	Number of circuits: 8 Open collector: Capacity 24 V DC Max. 50 mA
Control output OUT2 (DR, DS or DA option)	Relay contact 1a: Control capacity: 3 A 250 V AC (resistive load) (DR option) 1 A 250 V AC (inductive load $\cos\phi=0.4$ ) Electrical life: 100,000 cycles Non-contact voltage (For SSR drive): 12 V DC $\pm 15\%$ (DS option) Max. 40 mA (short circuit protected) (DA option) Direct current: 4 to 20 mA DC (Resolution: 12000) Load resistance: Max. 600 $\Omega$
Transmission output (TA, TV option)	Resolution: 12000 Output (TA option): 4 to 20 mA DC (Load resistance: Max. 500 $\Omega$ ) (TV option): 0 to 1 V DC (Load resistance: Minimum 100 k $\Omega$ )

## External Dimensions (Scale: mm)

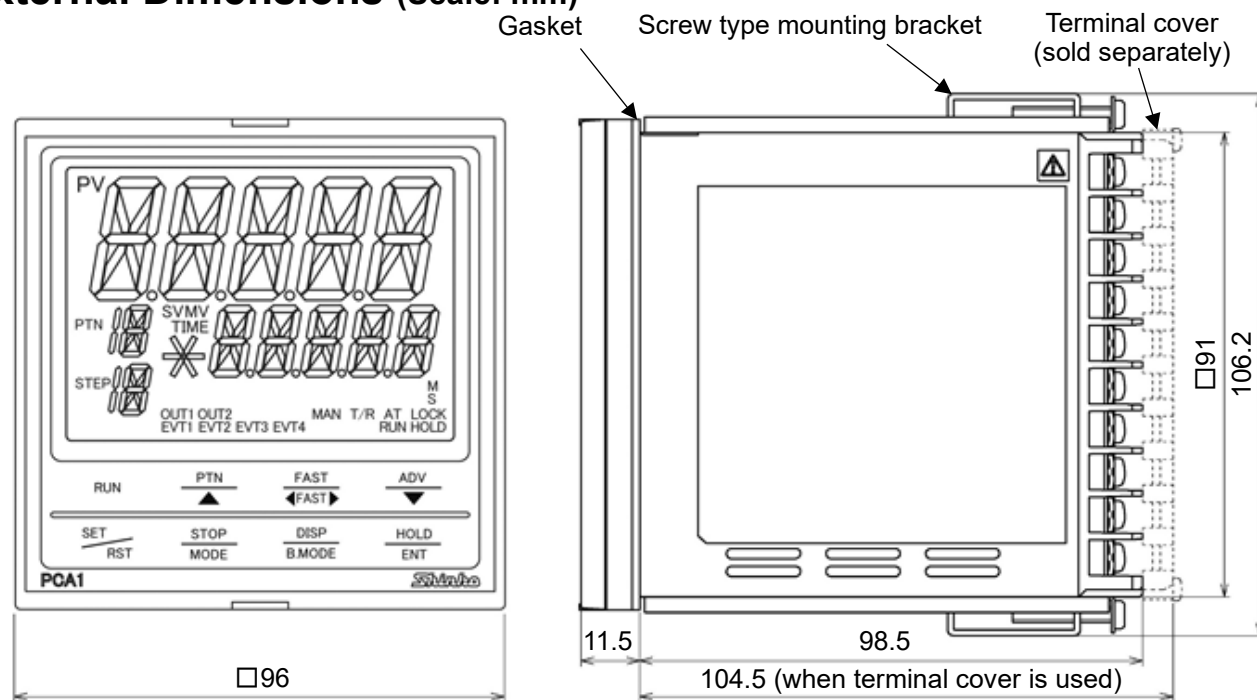

## Panel Cutout (Scale: mm)

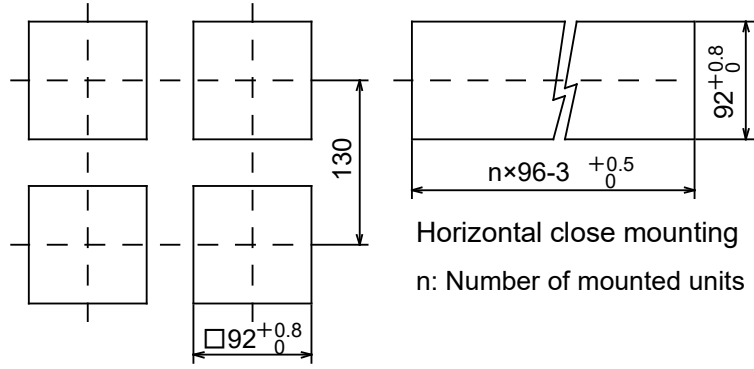

### ⚠ Caution

If horizontal close mounting is used for the controller, IP66 specification (Drip-proof/Dust-proof) may be compromised, and all warranties will be invalidated.

## Mounting and Removal of the Unit

### ⚠ Caution

As the case of the PCA1 is made of resin, do not use excessive force while tightening screws, or the mounting brackets could be damaged. The torque should be 0.12 N•m.

#### Mounting of the Unit

Mount the controller vertically to the flat, rigid panel to ensure it adheres to the Drip-proof/Dust-proof specification (IP66).

If the lateral close mounting is used for the controller, IP66 specification (Drip-proof/Dust-proof) may be compromised, and all warranties will be invalidated.

Mountable panel thickness: 1 to 8 mm

- (1) Insert the controller from the front side of the control panel.
  - (2) Attach mounting brackets by the holes top and bottom of the case, and secure the controller in place with the screws.
- The torque should be 0.12 N•m.

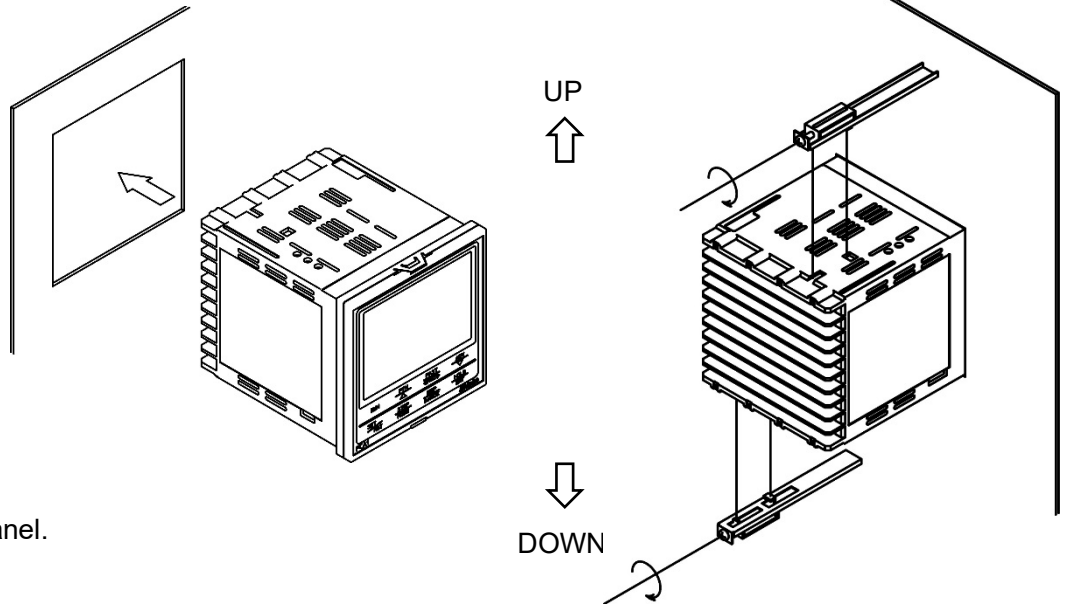

#### Removal of the Unit

- (1) Turn the power to the unit OFF, and disconnect all wires.
- (2) Loosen the screws of the mounting brackets, and remove the mounting brackets.
- (3) Pull the unit out from the front of the control panel.

## Names and Functions

#### PCA1 front panel

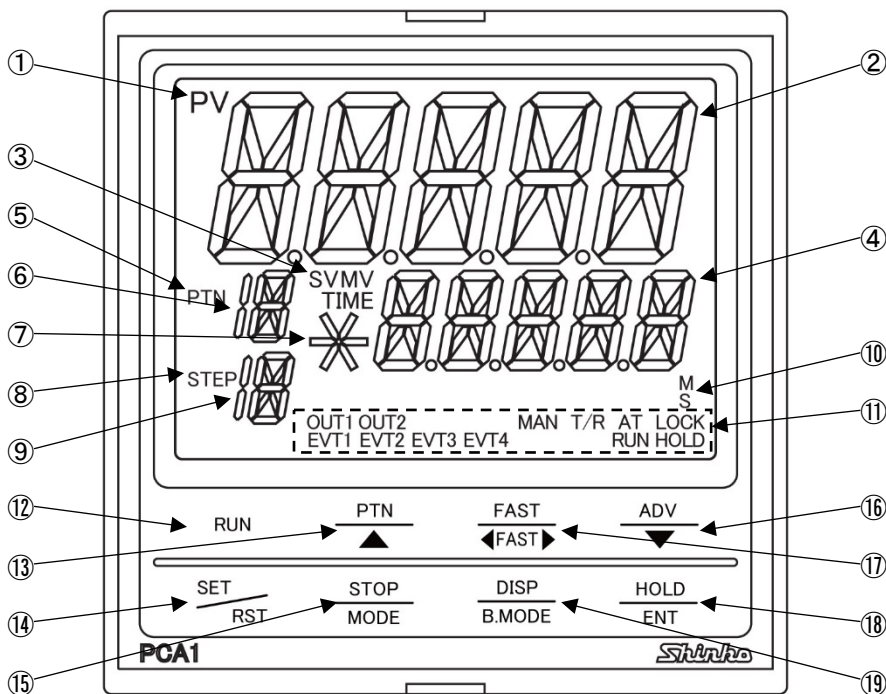

#### PCA1 bottom side

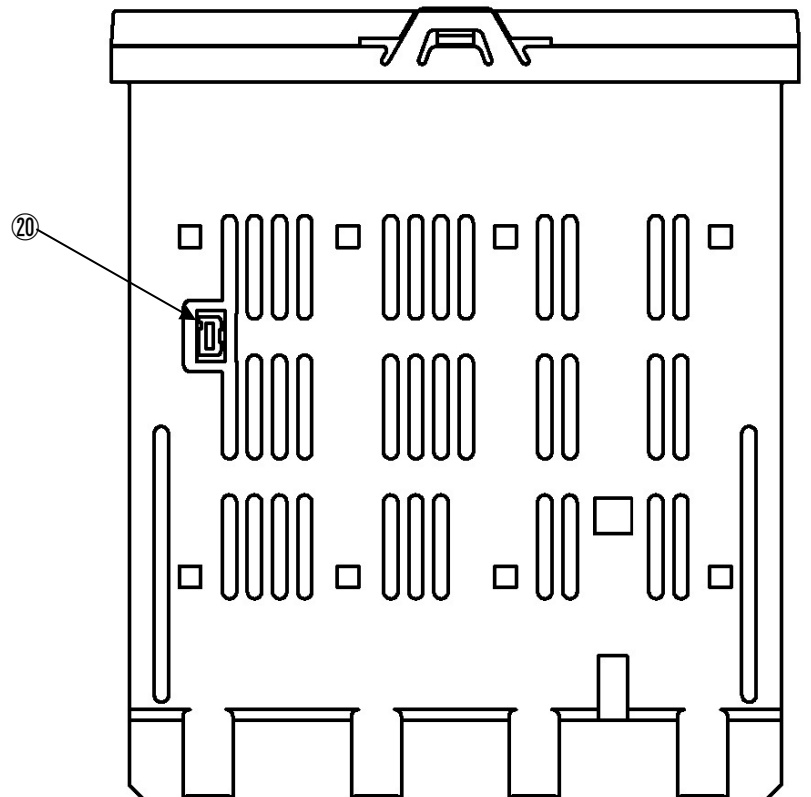

#### Indicator, Display

No.	Name	Description
①	<b>PV indicator</b>	Backlight: Red/Green/Orange Lit when PV is indicated in RUN mode.
②	<b>PV Display</b>	Backlight: Red/Green/Orange Indicates PV in RUN mode. Indicates setting characters in setting mode.

③	<b>SV indicator</b>	Backlight: Green Lit when SV is indicated on the SV/MV/TIME Display.
	<b>MV indicator</b>	Backlight: Green Lit when OUT1 MV is indicated on the SV/MV/TIME Display. Flashes when OUT2 MV is indicated on the SV/MV/TIME Display.
	<b>TIME indicator</b>	Backlight: Green Lit when TIME is indicated on the SV/MV/TIME Display.
④	<b>SV/MV/TIME Display</b>	Backlight: Green Indicates SV, MV or TIME in RUN mode. Indicates the set values in setting mode.
⑤	<b>PTN indicator</b>	Backlight: Orange Lit when the pattern number is indicated.
⑥	<b>PTN Display</b>	Backlight: Orange Indicates the pattern number. Flashes if 'Holding' is selected in [Step SV Hold function when program ends], when program control ends.
⑦	<b>PROFILE indicator</b>	Backlight: Green When program control is performing, the indicator lights up depending on the program setting as follows. ↗ : Lit when step SV is rising. ⇐ : Lit when step SV is constant. ↘ : Lit when step SV is falling.
⑧	<b>STEP indicator</b>	Backlight: Orange Lit when the step number is indicated.
⑨	<b>STEP Display</b>	Backlight: Orange Indicates the step number. The step number flashes during Wait action. Indicates <i>M</i> during Manual control.
⑩	<b>Time unit indicator</b>	Backlight: Green When the SV/MV/TIME Display indicates TIME, the following is shown depending on the selection in [Step time unit]. M: Lit when 'Hours:Minutes' is selected in [Step time unit]. S: Lit when 'Minutes:Seconds' is selected in [Step time unit].

#### Action Indicator (Backlight: Orange)

No.	Name	Description
⑪	<b>OUT1</b>	Lit when control output OUT1 is ON. For direct current output type, flashes corresponding to the MV in 125 ms cycles.
	<b>OUT2</b>	Lit when control output OUT2 (DR, DS or DA option) is ON. For direct current output type (DA option), flashes corresponding to the MV in 125 ms cycles.
	<b>EVT1</b>	Lit when Event output EV1 is ON.
	<b>EVT2</b>	Lit when Event output EV2 is ON.
	<b>EVT3</b>	Lit when Event output EV3 is ON.
	<b>EVT4</b>	Lit when Event output EV4 is ON.
	<b>MAN</b>	Lit when Manual control is performing.
	<b>T/R</b>	Lit during Serial communication (C or C5 option) TX (transmitting) output.
	<b>AT</b>	Flashes during AT (Auto-tuning). Lit in AT standby when 'Multi mode' is selected in [AT mode].
	<b>LOCK</b>	Lit when 'Lock' is selected in [Set value lock].
	<b>RUN</b>	Lit during program control RUN. Flashes during Fixed value control.
	<b>HOLD</b>	Flashes during program control HOLD.

#### Key, Connector

No.	Name	Description
⑫	<b>RUN key</b>	Performs program control. Cancels HOLD during Program control HOLD.
⑬	<b>PATTERN/UP key</b>	PATTERN key: Selects program pattern number. UP key: In setting mode, increases the numeric value of the set value.
⑭	<b>SET/RESET key</b>	SET key: Moves to setting mode. RESET key: Moves to RUN mode.
⑮	<b>STOP/MODE key</b>	STOP key: Stops the program control, or cancels the pattern end output. MODE key: Switches or selects setting mode.
⑯	<b>ADVANCE/DOWN key</b>	ADVANCE key: During program control, interrupts performing step, and proceeds to the next step (ADVANCE function). DOWN key: Decreases the numeric value of the set value in setting mode.
⑰	<b>FAST key</b>	During program control, makes step time progress 60 times faster. In setting mode, makes the numeric value change faster.
⑱	<b>HOLD/ENTER key</b>	HOLD key: During program control, time progress pauses, and control continues with the desired value at that time (HOLD function). ENTER key: Registers the setting data, and moves to the next item.
⑲	<b>DISPLAY/ BACK MODE key</b>	DISPLAY key: Switches the indication on the SV/MV/TIME Display. Maintains indication when power is OFF. BACK MODE key: Moves back to the previous mode.
⑳	<b>Console connector</b>	By connecting the USB communication cable (CMB-001, sold separately), the following operations can be conducted from an external computer using the Console software SWC-PCA101M. (1) Reading and setting of step SV, step time, PID and various set values (2) Reading of PV and action status (3) Function change

# Terminal Arrangement

## ⚠ Warning

Turn the power supply to the instrument off before wiring or checking.

Working on or touching the terminal with the power switched on may result in severe injury or death due to electrical shock.

## ⚠ Caution

- Do not leave wire remnants in the instrument, as they could cause a fire or malfunction.
- Use the solderless terminal with an insulation sleeve in which the M3 screw fits when wiring the instrument.
- The terminal block of this instrument is designed to be wired from the left side. The lead wire must be inserted from the left side of the terminal, and fastened with the terminal screw.
- Tighten the terminal screw using the specified torque. If excessive force is applied to the screw when tightening, the terminal screw or case may be damaged. The torque should be 0.63 N·m.
- Do not pull or bend the lead wire on the terminal side when wiring or after wiring, as it could cause malfunction.
- This instrument does not have a built-in power switch, circuit breaker and fuse. It is necessary to install a power switch, circuit breaker and fuse near the controller. (Recommended fuse: Time-lag fuse, rated voltage 250 V AC, rated current 2 A)
- For the grounding wire, use a thick wire (1.25 to 2.0 mm<sup>2</sup>).
- For a 24 V AC/DC power source, ensure polarity is correct when using direct current (DC).
- Do not apply a commercial power source to the sensor which is connected to the input terminal nor allow the power source to come into contact with the sensor.
- Use a thermocouple and compensating lead wire according to the sensor input specifications of this controller.
- Use the 3-wire RTD according to the sensor input specifications of this controller.
- For DC voltage input, (+) side input terminal number of 0 to 5 V DC, 1 to 5 V DC, 0 to 10 V DC differs from that of 0 to 10 mV DC, -10 to 10 mV DC, 0 to 50 mV DC, 0 to 100 mV DC, 0 to 1 V DC.
- When using a relay contact output type, externally use a relay according to the capacity of the load to protect the built-in relay contact.
- When wiring, keep input wires (thermocouple, RTD, etc.) away from AC sources or load wires.

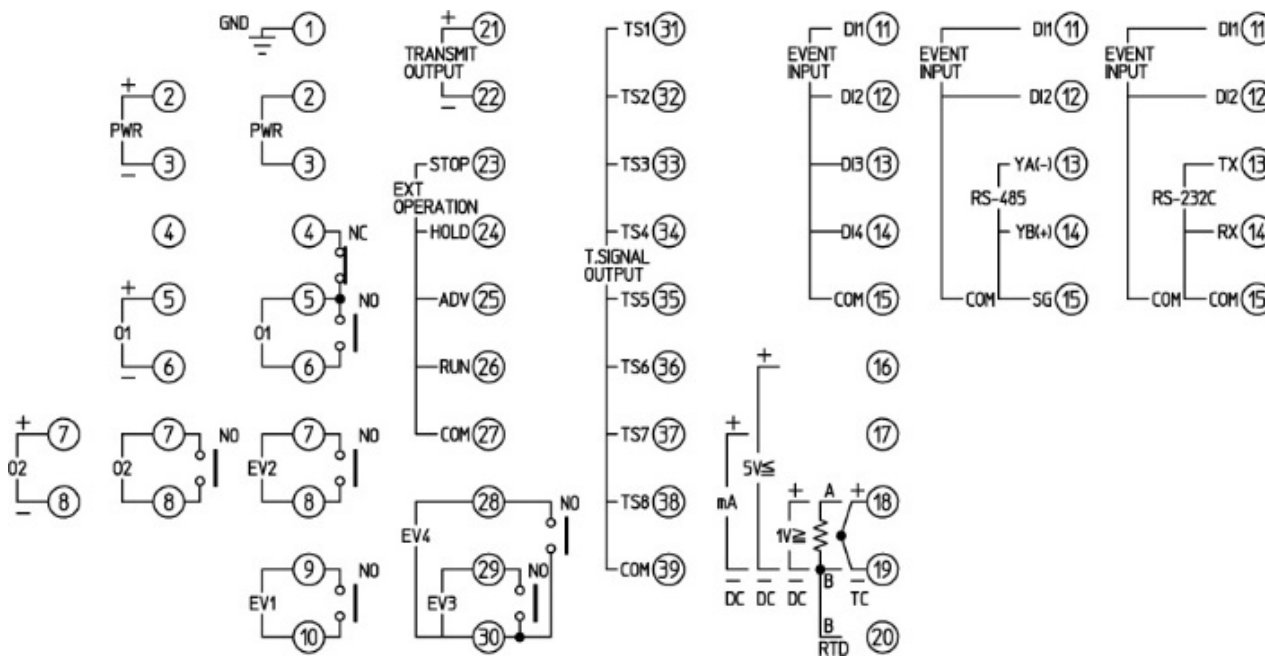

Terminal Code	Description
GND	Ground
PWR	Power supply voltage 100 to 240 V AC or 24 V AC/DC For a 24 V AC/DC power source, ensure polarity is correct when using direct current (DC).
O1	Control output OUT1
O2	Control output OUT2 (DR, DS or DA option)
EV1	Event output EV1
EV2	Event output EV2
EV3	Event output EV3
EV4	Event output EV4
EVENT INPUT	Event input
RS-485/RS-232C	Serial communication RS-485 (C5 option), or RS-232C (C option)
TC	Thermocouple input
RTD	RTD input
DC 1V $\geq$	DC voltage input: 0 to 10 mV DC, -10 to 10 mV DC, 0 to 50 mV DC, 0 to 100 mV DC, 0 to 1 V DC
DC 5V $\leq$	DC voltage input: 0 to 5 V DC, 1 to 5 V DC, 0 to 10 V DC
DC mA	Direct current input: 0 to 20 mA DC, 4 to 20 mA DC
TRANSMIT OUTPUT	Transmission output (TA or TV option)
EXT OPERATION	External operation input: STOP, HOLD, ADV, RUN
T.SIGNAL OUTPUT	Time signal output (TS option)