

# Mounting and wiring instruction manual

Communication Expansion Module **QMC1** No. QMC11E1 2021.02

## Preface

Thank you for purchasing our communication expansion module [QMC1] (hereinafter referred to as this instrument or communication expansion module).

This instruction manual (hereinafter referred to as this manual) describes the mounting method, functions, operation method, and handling of this instrument.

Please read this manual carefully and fully understand it before using it. Also, be sure to give this manual to users of this instrument to prevent accidents due to mishandling.

**For details on how to use it, refer to the instruction manual (detailed version) of each model.**

Please access our website from the following URL or QR code to download the instruction manual (detailed version).  
[http://www.shinko-technos.co.jp/e/download/d\\_manual\\_download.html#Q](http://www.shinko-technos.co.jp/e/download/d_manual_download.html#Q)

## Notes

- This instrument should be used in accordance with the specifications described in the manual. If it is not used according to the specifications, it may malfunction or cause a fire.
- Be sure to follow the warnings, cautions and notices. If they are not observed, serious injury or malfunction may occur.
- The contents of this instruction manual are subject to change without notice.
- Care has been taken to ensure that the contents of this instruction manual are correct, but if there are any doubts, mistakes or questions, please inform our sales department.
- This instrument is designed to be installed on a DIN rail within a control panel. If it is not, measures must be taken to ensure that the operator does not touch power terminals or other high voltage sections.
- Any unauthorized transfer or copying of this document, in part or in whole, is prohibited.
- Shinko Technos Co., Ltd. is not liable for any damage or secondary damage(s) incurred as a result of using this product, including any indirect damage.

## SAFETY PRECAUTIONS

(Be sure to read these precautions before using our products.)

The safety precautions are classified into categories: "Warning" and "Caution". Depending on circumstances, procedures indicated by **Warning** Caution may result in serious consequences, so be sure to follow the directions for usage.

**Warning** Procedures which may lead to dangerous conditions and cause death or serious injury, if not carried out properly.

**Caution** Procedures which may lead to dangerous conditions and cause superficial to medium injury or physical damage or may degrade or damage the product, if not carried out properly.

**Warning**

- To prevent an electrical shock or fire, only Shinko or qualified service personnel may handle the inner assembly.
- To prevent an electrical shock, fire, or damage to instrument, parts replacement may only be undertaken by Shinko or qualified service personnel.

**Safety Precautions**

- To ensure safe and correct use, thoroughly read and understand this manual before using this instrument.
- This instrument is intended to be used for industrial machinery, machine tools and measuring equipment. Verify correct usage after purpose-of-use consultation with our agency or main office. (Never use this instrument for medical purposes with which human lives are involved.)
- External protection devices such as protective equipment against excessive temperature rise, etc. must be installed, as malfunction of this product could result in serious damage to the system or injury to personnel. Proper periodic maintenance is also required.
- This instrument must be used under the conditions and environment described in this manual. Shinko Technos Co., Ltd. does not accept liability for any injury, loss of life or damage occurring due to the instrument being used under conditions not otherwise stated in this manual.

**Caution with Respect to Export Trade Control Ordinance**

To avoid this instrument from being used as a component in, or as being utilized in the manufacture of weapons of mass destruction (i.e. military applications, military equipment, etc.), please investigate the end users and the final use of this instrument. In the case of resale, ensure that this instrument is not illegally exported.

## Precautions for Use

### Installation Precautions

**Caution**

This instrument is intended to be used under the following environmental conditions (IEC61010-1):

- Overvoltage category II, Pollution degree 2

Ensure the mounting location corresponds to the following conditions:

- A minimum of dust, and an absence of corrosive gases
- No flammable, explosive gases
- No mechanical vibrations or shocks
- No exposure to direct sunlight, an ambient temperature of -10 to 55°C (14°F to 131°F) that does not change rapidly, and no icing
- An ambient non-condensing humidity of 35 to 85 %RH
- No large capacity electromagnetic switches or cables through which large current is flowing
- No water, oil or chemicals or the vapors of these substances can come into direct contact with the unit.
- When installing this unit within a control panel, please note that ambient temperature of this unit – not the ambient temperature of the control panel – must not exceed 55°C (131°F). Otherwise the life of electronic components (especially electrolytic capacitor) may be shortened.

\* Avoid setting this instrument directly on or near flammable material even though the case of this instrument is made of flame-resistant resin.

### Wiring Precautions

**Caution**

- Do not connect two or more control module QTC1-2P (with power supply / communication option) (hereinafter referred to as QTC1-2P) or QTC1-4P (with power supply / communication option) (hereinafter referred to as QTC1-4P) in one unit.
- When wiring, do not drop wire scraps into the ventilation window of this instrument. It may cause fire or malfunction.
- When wiring, use a crimping pliers and a solderless terminal with an insulation sleeve in which an M3 screw fits.
- Tighten the terminal screw using the specified torque. If excessive force is applied to the screw when tightening, the screw or case may be damaged.
- Do not pull or bend the lead wire with the terminal as the base point during or after wiring work. It may cause malfunction.
- This instrument does not have a built-in power switch, circuit breaker and fuse. It is necessary to install a power switch, circuit breaker and fuse near the instrument. (Recommended fuse: Time-lag fuse, rated voltage 250 V AC, rated current 2 A)
- When wiring the power supply (24 VDC), do not confuse the polarities.

### Operation and Maintenance Precautions

**Caution**

- Do not touch live terminals. This may cause electrical shock or problems in operation.
- Turn the power supply to the instrument OFF when retightening the terminal or cleaning. Working on or touching the terminal with the power switched ON may result in severe injury or death due to electrical shock.
- Use a soft, dry cloth when cleaning the instrument. (Alcohol based substances may tarnish or deface the unit.)
- As the display section is vulnerable, be careful not to put pressure on, scratch or strike it with a hard object.

## 1. Overview

This instrument is a communication extension module that can configure a multi-point control system via a host computer or PLC. A maximum of 16 control modules QTC1-20 (no power supply / communication option) (hereinafter referred to as QTC1-20) (hereinafter referred to as QTC1-20) or QTC1-40 (no power supply / communication option) (hereinafter referred to as QTC1-40) can be connected via BUS, and a maximum of 64 points can be controlled. One block connected to BUS is called "1 unit". In addition, a maximum of 16 units can be connected and a maximum of 1024 points can be controlled.

Connection example of QMC1 and QTC1-40

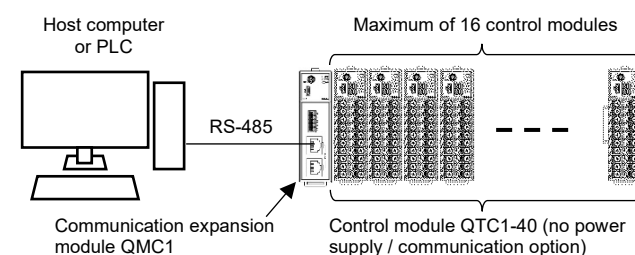

## 2. Model

QMC1	-	□	-	
Communication type	C4			RS-422A
	C5			RS-485 (*1)
Option Event input/output	0			No option
	1			Event input (4 points) (*2)
	2			Event output (4 points) (*2)
	3			Event input (2 points), Event output (2 points) (*2)
Communication protocol	0			Console selection (MODBUS RTU/SIF function) (*1)
	1			C series compatible

(\*1) When connecting to an OMRON PLC with the SIF function, the RS-485 communication type cannot be used. Only RS-422A communication type can be connected.

(\*2): The plug side connector of the event input / output connector is sold separately.

## 3. Name and Functions

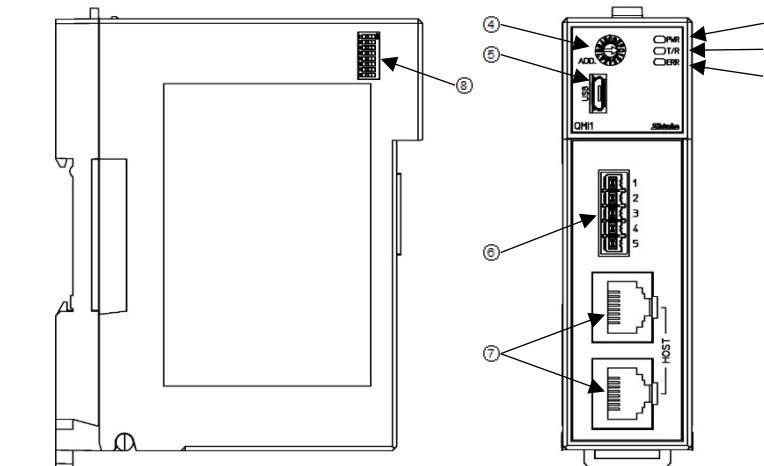

Base part

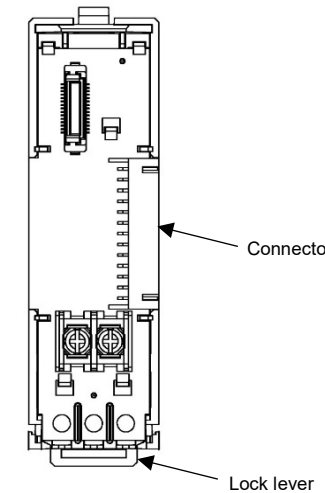

Operation indicator

No.	Symbol (color)	Name and Function
①	PWR (Green)	Power indicator
②	T/R (Yellow)	Communication indicator
③	ERR (Red)	ERR indicator

Switch and connector

No.	Symbol (color)	Name and Function
④	ADD.	Module address selection rotary switch
⑤	USB	Console communication connector
⑥		Event input/output connector [0225-3705 (DINKLE)] (Option)
⑦		Serial communication connector [Modular jack (RJ45)]
⑧		Communication specification selection dip switch

## 4. Communication Parameter Setting

### 4.1 Selection of Communication Specifications

Use the communication specification selection dip switch on the left side of this instrument to select communication specifications.

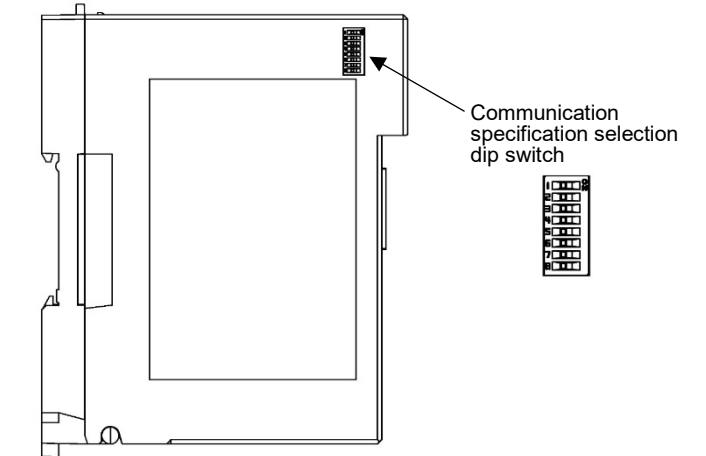

Select the communication speed, data bit, parity and stop bit. All are off when shipped from the factory.

- Communication speed: 9600 bps
- Data bit: 8 bits
- Parity Enable/Disable: Enable
- Parity Even / Odd: Even
- Stop bit: 1 bit

(1) Communication speed

Communication specification selection dip switch		Communication speed
1	2	
OFF	OFF	9600 bps
ON	OFF	19200 bps
OFF	ON	38400 bps
ON	ON	57600 bps

(2) Data bit

Communication specification selection dip switch	Data bit
3	
OFF	8 bits
ON	7 bits

(3) Parity Enable/Disable

Communication specification selection dip switch	Parity Enable/Disable
4	
OFF	Enable
ON	Disable

(4) Parity Even / Odd

Communication specification selection dip switch	Parity Even / Odd
5	
OFF	Even
ON	Odd

(5) Stop bit

Communication specification selection dip switch	Stop bit
6	
OFF	1 bit
ON	2 bits

Dip switches No.7 and No.8 does not use. Leave it OFF.

### 4.2 Selection of Module Address

**Caution**

- The QMC1 module address selection is required to communicate with the host computer or PLC. The QTC1-20 or QTC1-40 module address selection is required to communicate with the QMC1.
- The module address of QMC1 differs depending on the model name.

The module address is selected with the rotary switch.

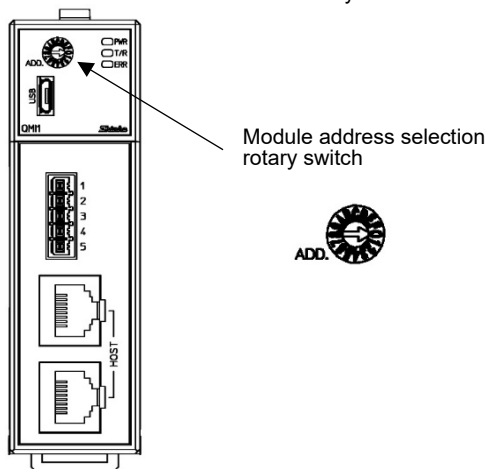

Use a small flat blade screwdriver to select the module address. The module address of QMC1 differs depending on the model name.

For QMC1-□□□-0 [Console selection (MODBUS RTU/SIF)]

The value obtained by adding 1 to the value of the selected rotary switch becomes the module address.

Module address: 0 to F (1 to 16)

Value of rotary switch	0	1	9	A	B	F
Module address	1	2	10	11	12	16

For QMC1-□□□-1 (C series compatible)

The value of the selected rotary switch becomes the module address.

Module address: 0 to F (0 to 15)

Value of rotary switch	0	1	9	A	B	F
Module address	0	1	9	10	11	15

## 5. Mounting

### Caution

- Do not connect QTC1-2P or QTC1-4P in the same unit.
- For the QMC1-□□□-1 (C series compatible), the maximum connection "modules / channels" is "5 modules / 20 channels".
- Mount the DIN rail horizontally.
- This instrument fits the following DIN rails. Top hat rail TH35 JIS C 2812-1988
- If this instrument is mounted in a position susceptible to vibration or shock, mount commercially available end plate at both ends of the instrument.
- When installing, make sure that the orientation (upper and lower) of this instrument is correct.
- When mounting or removing this instrument on the DIN rail, it must be tilted slightly. Secure a space of 50 mm or more in the vertical direction of the instrument, considering the wiring space of the power supply/communication line and heat dissipation.

Spacing when QMC1 and QTC1-40 are connected

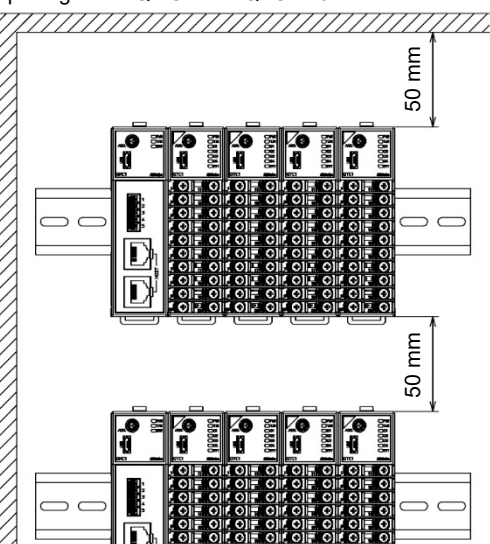

## 5.1 Mounting

Mounting to the DIN rail

- Lower the lock lever of this instrument. (The lock lever of this instrument has a spring structure, but if lower it in the direction of the arrow until it stops, it will be locked in that position.)
- Hook the part ② of this instrument onto the top of the DIN rail.
- Insert the lower part of this instrument with the part ② as a fulcrum.
- Raise the lock lever of this instrument. Make sure it is fixed to the DIN rail.

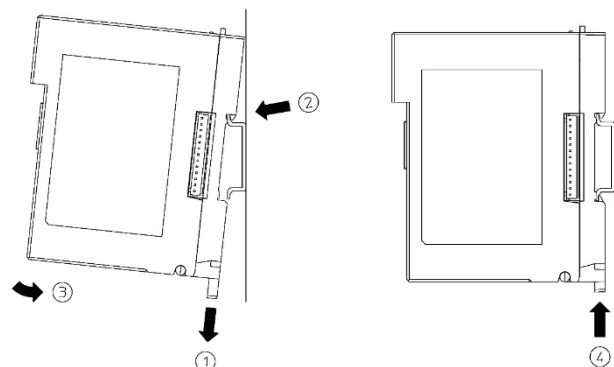

Removal from the DIN rail

- Insert a flat blade screwdriver into the lock lever of this instrument and lower the lock lever until it stops.
- Remove this instrument from the DIN rail by lifting it from below.

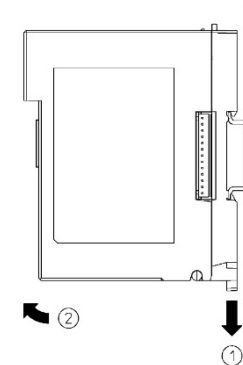

Mounting multiple modules to the DIN rail

This section describes an example of mounting this instrument and control module QTC1-40 on the DIN rail.

- Lower the lock lever of the QTC1-40, and mounting the QTC1-40 to the DIN rail.
- Slide the QTC1-40 to the left and connect the connectors to each other.

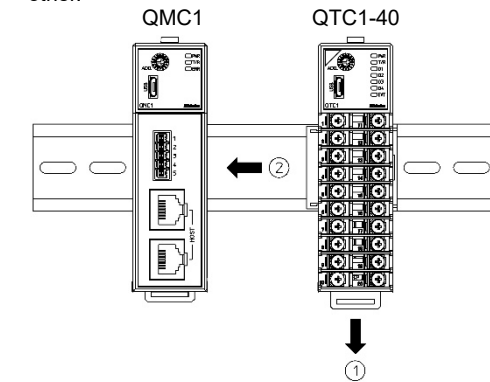

- Raise the lock lever of the QTC1-40. Make sure it is fixed to the DIN rail.

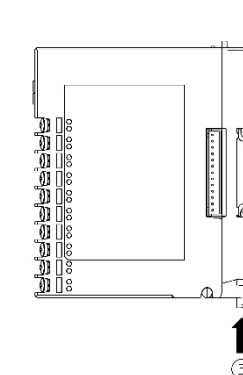

## 5.2 External Dimensions

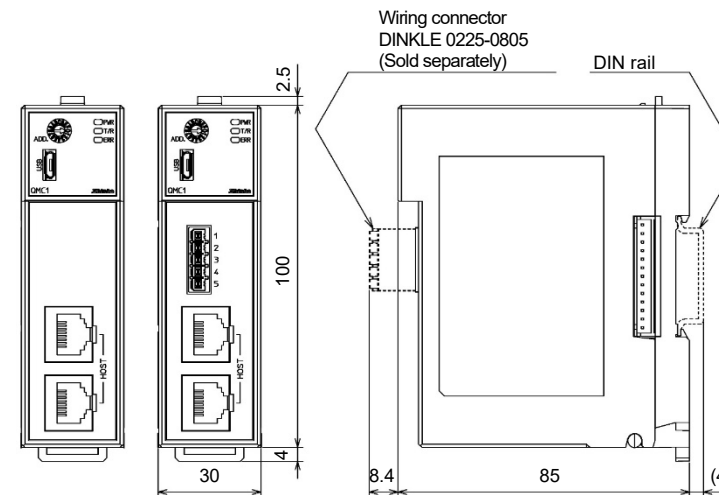

## 6. Wiring

### Warning

Turn off the power supply to this instrument before wiring. If you work while the power is supplied, you may get an electric shock, which could result in an accident resulting in death or serious injury.

### Caution

Do not connect QTC1-2P or QTC1-4P in the same unit.

### 6.1 Recommended Terminal

Use a solderless terminal with an insulation sleeve in which an M3 screw fits as shown below. Use the Ring-type for the power supply and serial communication section.

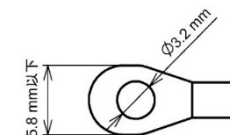

Solderless Terminal	Manufacturer	Model	Tightening torque
Ring-type	Nichifu Terminal Industries Co., Ltd.	TMEV1.25-3	0.5 N · m
	Japan Solderless Terminal MFG Co., Ltd.	V1.25-3	

### 6.2 Pin and Terminal Arrangement

6.2.1 Pin Array of Event Input (Option) / Output and Serial Communication Part

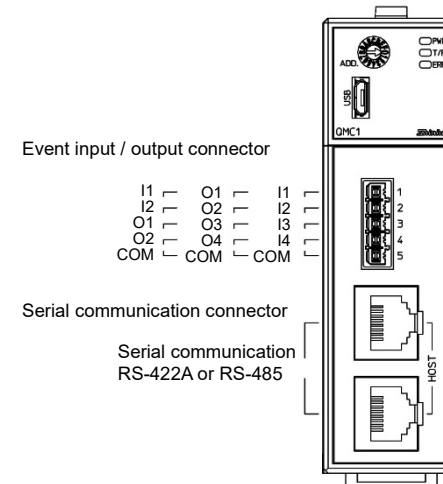

(1) Pin arrangement of event input / output connector  
Using the event input/output connector [0225-0805 (DINKLE)] (sold separately).

Pin No.	Model	QMC1-□□1-□	QMC1-□□2-□	QMC1-□□3-□
1	I1 (Event input 1)	O1 (Event output 1)	I1 (Event input 1)	
2	I2 (Event input 2)	O2 (Event output 2)	I2 (Event input 2)	
3	I3 (Event input 3)	O3 (Event output 3)	O1 (Event output 1)	
4	I4 (Event input 4)	O4 (Event output 4)	O2 (Event output 2)	
5	COM	COM	COM	

(2) Pin arrangement of serial communication connector

(Upper and lower connectors common)

For serial communication, use the following communication cables (sold separately).

Between host computer or PLC and QMC1

USB communication cable (CMC-001-4) [USB - Modular]

Communication cable (CQM-001) [Y-terminal (C5, 3-wire) - Modular]

Communication cable (CQM-002) [Y-terminal (C4, 5-wire) - Modular]

Between QMC1 and QMC1

Communication cable (CQQ-001) [Modular - Modular]

Pin No.	Model	QMC1-C4□□	QMC1-C5□□
8 1	8	NC	NC
	7	SG	SG
	6	RD(+)	NC
	5	SD(+)	YB(+)
	4	SD(-)	YA(-)
8 1	3	RD(-)	NC
	2	SG	SG
	1	NC	NC

6.2.2 Power Supply Terminal Arrangement

The terminal block for power supply and serial communication is located on the base of this instrument.

Wiring by the following procedure.

(1) Case removal

- Push the release lever on the top of this instrument to unlock it.
- Remove the case.

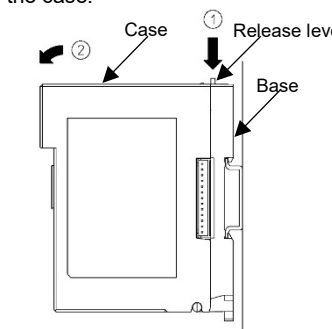

(2) Wiring

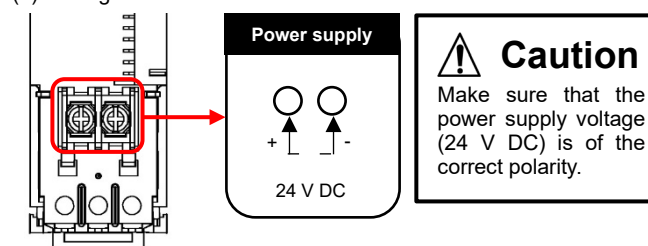

(3) Case mounting

- Hook the case on the lower part ① of this instrument.
- Mount the case so that the lower part ① of this instrument is the fulcrum and covers the release lever. There is a clicking sound.

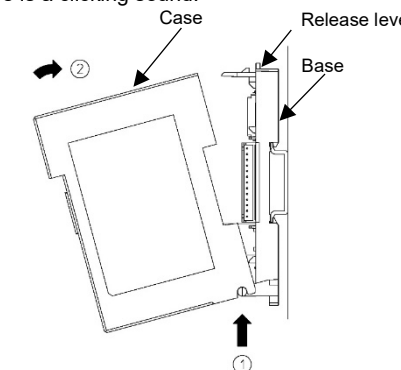

## SHINKO TECHNOS CO., LTD. OVERSEAS DIVISION

Head Office: 2-5-1, Senbahigashi, Mino, Osaka, Japan  
 URL: <http://www.shinko-technos.co.jp/e/> Tel: +81-72-727-6100  
 E-mail: [overseas@shinko-technos.co.jp](mailto:overseas@shinko-technos.co.jp) Fax: +81-72-727-7006