

# Mounting and wiring instruction manual

Communication Expansion Module **QMC1-C** No. QMC11E6 2023.07

## Preface

Thank you for purchasing our communication expansion module [QMC1-C] (hereinafter referred to as this instrument or communication expansion module). This instruction manual (hereinafter referred to as this manual) describes the specifications, mounting method, functions, operation method, and handling of this instrument. Please read this manual carefully and fully understand it before using it. Also, be sure to give this manual to users of this instrument to prevent accidents due to mishandling.

For details on how to use it, refer to the instruction manual (detailed version) of QMC1-C. Please access our website from the following URL or QR code to download the instruction manual (detailed version).  
[https://shinko-technos.co.jp/e/download/d\\_manual\\_download.html#Q](https://shinko-technos.co.jp/e/download/d_manual_download.html#Q)



## Notes

- This instrument should be used in accordance with the specifications described in the manual. If it is not used according to the specifications, it may malfunction or cause a fire.
- Be sure to follow the warnings, cautions and notices. If they are not observed, serious injury or malfunction may occur.
- The contents of this instruction manual are subject to change without notice.
- Care has been taken to ensure that the contents of this instruction manual are correct, but if there are any doubts, mistakes or questions, please inform our sales department.
- This instrument is designed to be installed on a DIN rail within a control panel indoors. If it is not, measures must be taken to ensure that the operator does not touch power terminals or other high voltage sections.
- Any unauthorized transfer or copying of this document, in part or in whole, is prohibited.
- Shinko Technos Co., Ltd. is not liable for any damage or secondary damage(s) incurred as a result of using this product, including any indirect damage.

## SAFETY PRECAUTIONS

(Be sure to read these precautions before using our products.)  
 The safety precautions are classified into categories: "Warning" and "Caution". Depending on circumstances, procedures indicated by ⚠ Caution may result in serious consequences, so be sure to follow the directions for usage.

- Warning** Procedures which may lead to dangerous conditions and cause death or serious injury, if not carried out properly.
- Caution** Procedures which may lead to dangerous conditions and cause superficial to medium injury or physical damage or may degrade or damage the product, if not carried out properly.

- Warning**
  - To prevent an electrical shock or fire, only Shinko or qualified service personnel may handle the inner assembly.
  - To prevent an electrical shock, fire, or damage to instrument, parts replacement may only be undertaken by Shinko or qualified service personnel.

- Safety Precautions**
  - To ensure safe and correct use, thoroughly read and understand this manual before using this instrument.
  - This instrument is intended to be used for industrial machinery, machine tools and measuring equipment. Verify correct usage after purpose-of-use consultation with our agency or main office. (Never use this instrument for medical purposes with which human lives are involved.)
  - External protection devices such as protective equipment against excessive temperature rise, etc. must be installed, as malfunction of this product could result in serious damage to the system or injury to personnel. Proper periodic maintenance is also required.
  - This instrument must be used under the conditions and environment described in this manual. Shinko Technos Co., Ltd. does not accept liability for any injury, loss of life or damage occurring due to the instrument being used under conditions not otherwise stated in this manual.

## Meaning of Warning Message on Model Label

- Caution** If do not handle this instrument correctly, may suffer minor or moderate injury or property damage due to fire, malfunction, or electric shock. Please read this manual carefully and fully understand it before using it.

- Caution with Respect to Export Trade Control Ordinance**  
 To avoid this instrument from being used as a component in, or as being utilized in the manufacture of weapons of mass destruction (i.e. military applications, military equipment, etc.), please investigate the end users and the final use of this instrument. In the case of resale, ensure that this instrument is not illegally exported.

## Precautions for Use

### Installation Precautions

- Caution** This instrument is intended to be used under the following environmental conditions (EN61010-1):
  - Pollution degree 2
 Ensure the mounting location corresponds to the following conditions:
  - A minimum of dust, and an absence of corrosive gases
  - No flammable, explosive gases
  - No mechanical vibrations or shocks
  - No exposure to direct sunlight, an ambient temperature of -10 to 50°C (14°F to 122°F) that does not change rapidly, and no icing
  - An ambient non-condensing humidity of 35 to 85%RH
  - No large capacity electromagnetic switches or cables through which large current is flowing
  - No water, oil or chemicals or the vapors of these substances can come into direct contact with the unit.
  - When installing this unit within a control panel, please note that ambient temperature of this unit – not the ambient temperature of the control panel – must not exceed 50°C (122°F). Otherwise the life of electronic components (especially electrolytic capacitor) may be shortened.
  - Avoid setting this instrument directly on or near flammable material even though the case of this instrument is made of flame-resistant resin.

## Wiring Precautions

- Caution**
  - Do not connect two or more control module QTC1-2P (with power supply / communication option) (hereinafter referred to as QTC1-2P) or QTC1-4P (with power supply / communication option) (hereinafter referred to as QTC1-40) in one unit.
  - When wiring, do not drop wire scraps into the ventilation window of this instrument. It may cause fire or malfunction.
  - When wiring, use a crimping pliers and a solderless terminal with an insulation sleeve in which an M3 screw fits.
  - Tighten the terminal screw using the specified torque. If excessive force is applied to the screw when tightening, the screw or case may be damaged.
  - Do not pull or bend the lead wire with the terminal as the base point during or after wiring work. It may cause malfunction.
  - This instrument does not have a built-in power switch, circuit breaker and fuse. It is necessary to install an appropriate power switch, circuit breaker and fuse near the instrument.
  - When wiring the power supply (24 VDC), do not confuse the polarities.
  - Use copper wires AWG16 to 14 (1.31 to 2.08 mm<sup>2</sup>) for the FG terminal and Power supply terminal.

## Operation and Maintenance Precautions

- Caution**
  - Do not touch live terminals. This may cause electrical shock or problems in operation.
  - Turn the power supply to the instrument OFF when retightening the terminal or cleaning. Working on or touching the terminal with the power switched ON may result in severe injury or death due to electrical shock.
  - Use a soft, dry cloth when cleaning the instrument. (Alcohol based substances may tarnish or deface the unit.)
  - As the display section is vulnerable, be careful not to put pressure on, scratch or strike it with a hard object.

## Compliance with Safety Standards

- Caution**
  - If the instrument is used in a manner not specified by the manufacturer, the protection provided by the instrument may be impaired.
  - Use equipment that is reinforced-insulated or double-insulated from the primary power supply for external circuits connected to this instrument.
  - When using this product as a UL certified product, use a power supply conforming to Class 2 or LIM for the external circuit connected to the product.

## 1. Specifications

Power supply voltage	24 V DC
Allowable voltage fluctuation	20 to 28 V DC
Power consumption	3 W or less
Ambient temperature	-10 to 50 °C (no condensation or freezing)
Ambient humidity	35 to 85 %RH (no condensation)
Altitude	2,000 m or less
Weight	Approx. 140 g
Installation environment	Pollution degree 2 (EN61010-1)
Memory protection	Non-volatile memory (Number of writes: 1 million times)
Event input	Input type: Voltage contact input sink type Circuit current when closed: Approx. 6 mA Import judgment time: Approx. 100 ms Circuit: NPN open collector Max. load voltage: 30 V DC Max. load capacity: 50 mA
Event output	
Host-to-module communication	
Communication line	EIA RS-422A, EIA RS-485
Communication method	Half-duplex communication
Synchronization method	Start-stop synchronization
Communication speed	9600 bps, 19200 bps, 38400 bps, 57600 bps can be selected by DIP switch
Data bit/Parity/Stop bit	Select the following with the DIP switch Data bit: 8 Parity: Even, Odd, No parity Stop bit: 1 or 2
Communication response delay time	Set the delay time to return the response from this instrument after receiving the command from the host. 0 to 1000 ms
Number of connections	This instrument: Max 16 modules For C SERIES COMPATIBLE, max 5 modules
SIF function	A function to read and write various data to PLC registers using the communication protocol of PLCs made by each company.
Module-to-module communication	
Communication line	Internal Bus
Communication method	Half-duplex communication
Synchronization method	Start-stop synchronization
Communication speed	57600 bps
Data bit/Parity/Stop bit	Data bit: 8 Parity: Even Stop bit: 1

## 2. Overview

This instrument is a communication extension module that can configure a multi-point control system via a host computer or PLC. A maximum of 16 control modules QTC1-20 (no power supply / communication option) (hereinafter referred to as QTC1-20) or QTC1-40 (no power supply / communication option) (hereinafter referred to as QTC1-40) can be connected via BUS, and a maximum of 64 points can be controlled. One block connected to BUS is called "1 unit". In addition, a maximum of 16 units can be connected and a maximum of 1024 points can be controlled.

Connection example of QMC1-C and QTC1-40

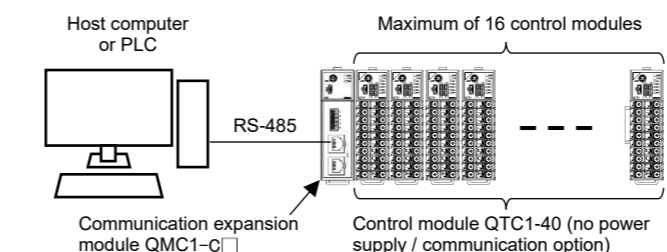

## 3. Model

QMC1	-C		
Communication type	C4		RS-422A
	C5		RS-485 (*1)
Option	0		No option
	1		Event input (4 points) (*2)
	2		Event output (4 points) (*2)
	3		Event input (2 points), Event output (2 points) (*2)
Communication protocol	0		Console selection (MODBUS RTU/SIF function) (*1)
	1		C series compatible

- (\*1) When using the SIF function to connect to a PLC manufactured by OMRON Corporation or KEYENCE CORPORATION, cannot be connected with RS-485 communication method. Only RS-422A communication type can be connected.
- (\*2): The plug side connector of the event input / output connector is sold separately.

## 4. Name and Functions

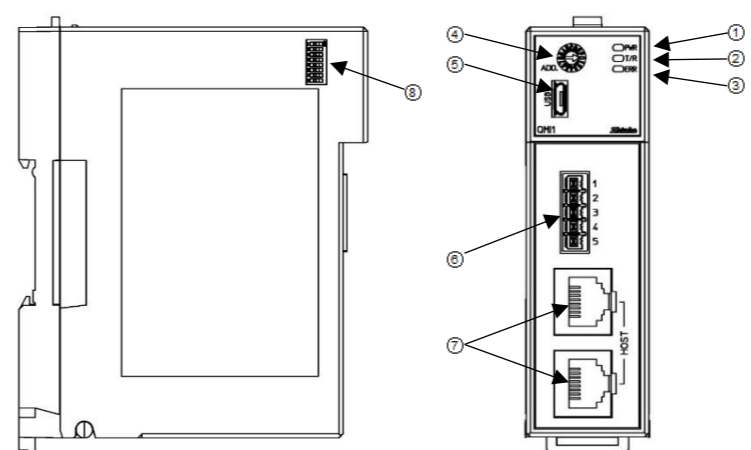

Base part

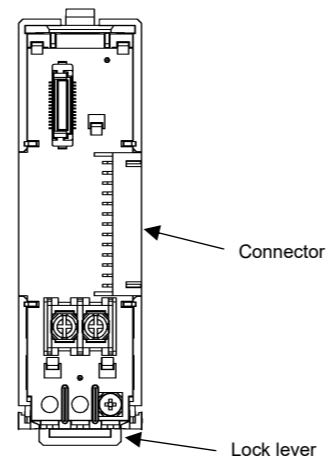

Operation indicator		
No.	Symbol (color)	Name and Function
①	PWR (Green)	Power indicator
②	T/R (Yellow)	Communication indicator
③	ERR (Red)	ERR indicator

Switch and connector

No.	Symbol (color)	Name and Function
④	ADD.	Module address selection rotary switch
⑤	USB	Console communication connector
⑥		Event input/output connector [0225-3705 (DINKLE)] (Option)
⑦		Serial communication connector [Modular jack (RJ45)]
⑧		Communication specification selection dip switch

## 5. Communication Parameter Setting

5.1 Selection of Communication Specifications  
 Use the communication specification selection dip switch on the left side of this instrument to select communication specifications.

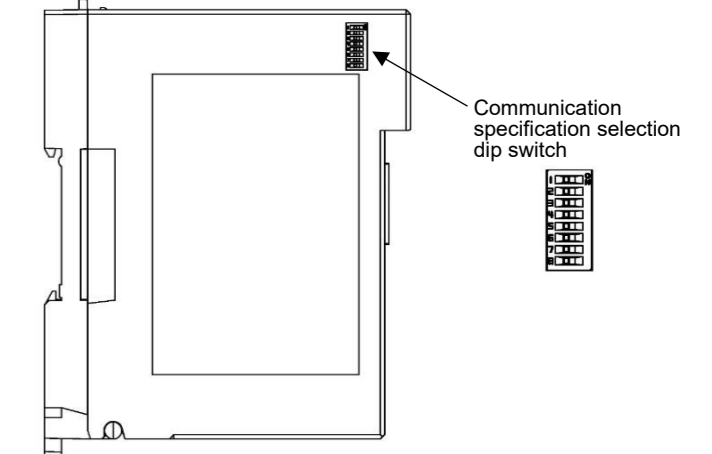

- Select the communication speed, data bit, parity and stop bit. All are off when shipped from the factory.
- Communication speed: 9600 bps
  - Data bit: 8 bits
  - Parity Enable/Disable: Enable
  - Parity Even / Odd: Even
  - Stop bit: 1 bit

(1) Communication speed

Communication specification selection dip switch		Communication speed
1	2	
OFF	OFF	9600 bps
ON	OFF	19200 bps
OFF	ON	38400 bps
ON	ON	57600 bps

(2) Data bit

Communication specification selection dip switch		Data bit
3		
OFF	OFF	8 bits
ON	ON	7 bits

(3) Parity Enable/Disable

Communication specification selection dip switch		Parity Enable/Disable
4		
OFF	OFF	Enable
ON	ON	Disable

(4) Parity Even / Odd

Communication specification selection dip switch		Parity Even / Odd
5		
OFF	OFF	Even
ON	ON	Odd

(5) Stop bit

Communication specification selection dip switch		Stop bit
6		
OFF	OFF	1 bit
ON	ON	2 bits

Dip switches No.7 and No.8 does not use. Leave it OFF.

## 5.2 Selection of Module Address

### Caution

- The QMC1-C□ module address selection is required to communicate with the host computer or PLC.
- The QTC1-20 or QTC1-40 module address selection is required to communicate with the QMC1-C□.
- The module address of QMC1-C□ differs depending on the model name.

The module address is selected with the rotary switch.

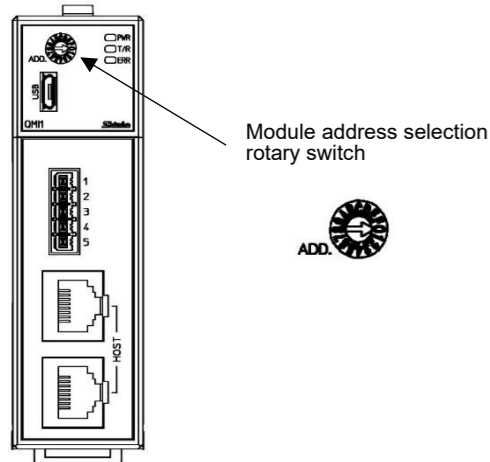

Use a small flat blade screwdriver to select the module address. The module address of QMC1-C□ differs depending on the model name.

For QMC1-□□□-0 [Console selection (MODBUS RTU/SIF)]

The value obtained by adding 1 to the value of the selected rotary switch becomes the module address.

Value of rotary switch	0	1	9	A	B	F
Module address	1	2	10	11	12	16

For QMC1-□□□-1 (C series compatible)

The value of the selected rotary switch becomes the module address.

Value of rotary switch	0	1	9	A	B	F
Module address	0	1	9	10	11	15

## 6. Mounting

### Caution

- Turn off the power supply to this instrument when mounting or removing it.
  - Do not connect QTC1-2P or QTC1-4P in the same unit.
  - For the QMC1-□□□-1 (C series compatible), the maximum connection "modules / channels" is "5 modules / 20 channels".
  - When installing, make sure that the orientation (upper and lower) of this instrument is correct.
  - When mounting or removing this instrument on the DIN rail, it must be tilted slightly.
- Secure a space of 50 mm or more in the vertical direction of the instrument, considering the wiring space of the power supply/communication line and heat dissipation.

Spacing when QMC1-C□ and QTC1-40 are connected

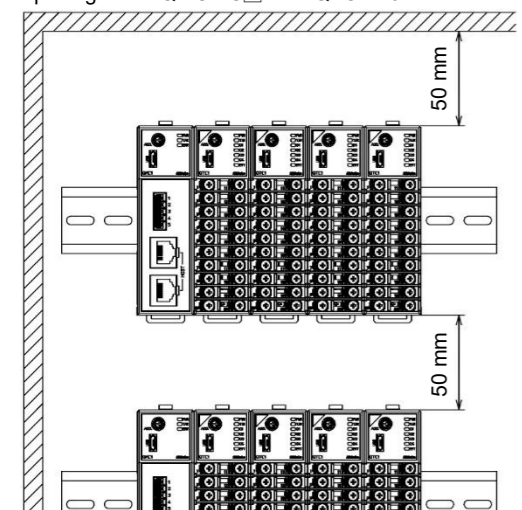

- Mount the DIN rail horizontally.
- This instrument fits the following DIN rails. Top hat rail TH35 JIS C 2812-1988
- If this instrument is mounted in a position susceptible to vibration or shock, mount commercially available end plate at both ends of the instrument.

## 6.1 Mounting

Mounting to the DIN rail

- Lower the lock lever of this instrument. (The lock lever of this instrument has a spring structure, but if lower it in the direction of the arrow until it stops, it will be locked in that position.)
- Hook the part ② of this instrument onto the top of the DIN rail.
- Insert the lower part of this instrument with the part ② as a fulcrum.
- Raise the lock lever of this instrument. Make sure it is fixed to the DIN rail.

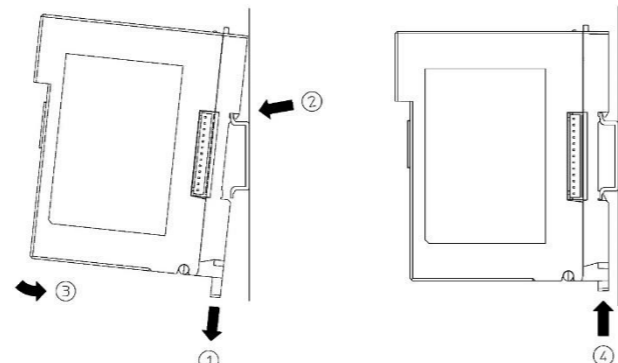

Removal from the DIN rail

- Insert a flat blade screwdriver into the lock lever of this instrument and lower the lock lever until it stops.
- Remove this instrument from the DIN rail by lifting it from below.

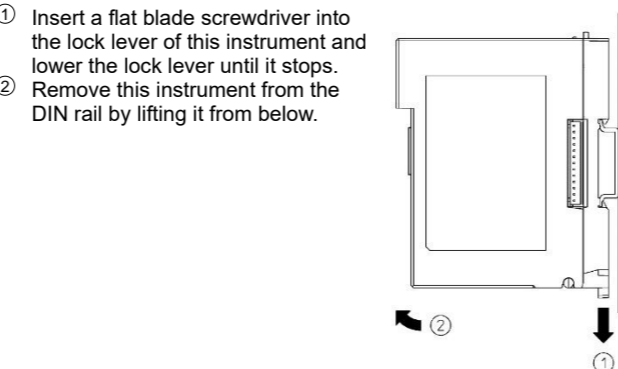

Mounting multiple modules to the DIN rail

This section describes an example of mounting this instrument and control module QTC1-40 on the DIN rail.

- Lower the lock lever of the QTC1-40, and mounting the QTC1-40 to the DIN rail.
- Slide the QTC1-40 to the left and connect the connectors to each other.

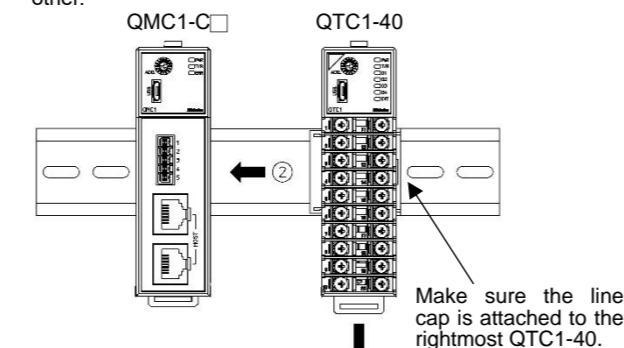

- Raise the lock lever of the QTC1-40. Make sure it is fixed to the DIN rail.

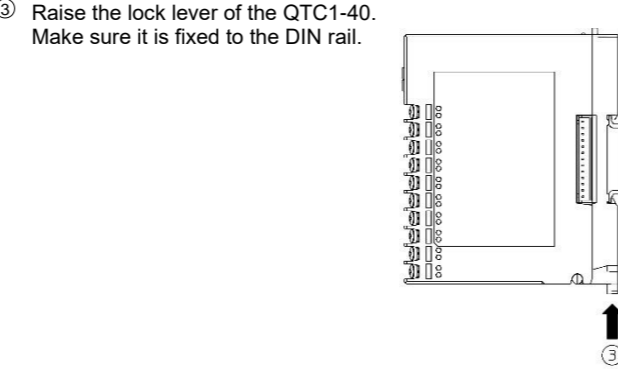

## 6.2 External Dimensions

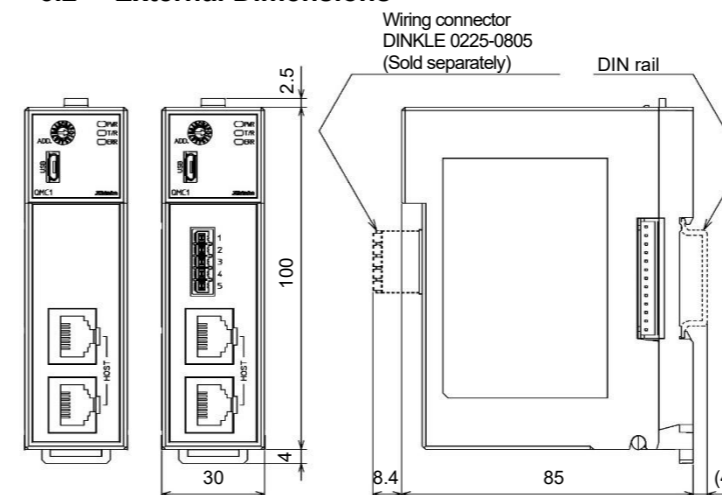

## 7. Wiring

### Warning

Turn off the power supply to this instrument before wiring. If you work while the power is supplied, you may get an electric shock, which could result in an accident resulting in death or serious injury.

### Caution

Do not connect QTC1-2P or QTC1-4P in the same unit.

## 7.1 Recommended Terminal

Use a solderless terminal with an insulation sleeve in which an M3 screw fits as shown below.

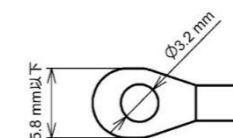

Solderless Terminal	Manufacturer	Model	Compatible wire size	Tightening torque
Ring-type	NICHIFU TERMINAL INDUSTRIES CO., LTD.	TMEX1.25-3	AWG22 to 16	Power supply terminal: 0.5 N·m FG terminal: 0.3 N·m
		TMEX2-3S	AWG16 to 14	
	J.S.T.MFG.CO.,LTD.	V1.25-3	AWG22 to 16	
		V2-MS3	AWG16 to 14	

## 7.2 Pin and Terminal Arrangement

7.2.1 Pin Array of Event Input (Option) / Output and Serial Communication Part

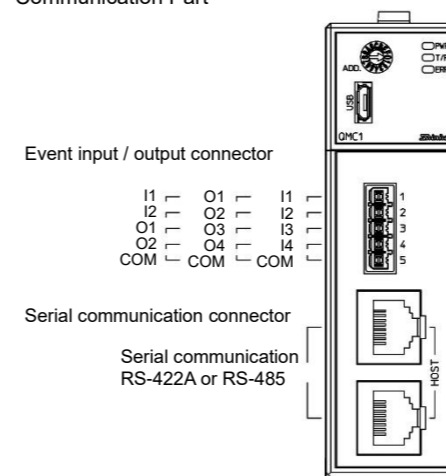

(1) Pin arrangement of event input / output connector

Using the event input/output connector [0225-0805 (DINKLE)] (sold separately).

Model	QMC1-□□1-□	QMC1-□□2-□	QMC1-□□3-□
Pin No. 1	I1 (Event input 1)	O1 (Event output 1)	I1 (Event input 1)
Pin No. 2	I2 (Event input 2)	O2 (Event output 2)	I2 (Event input 2)
Pin No. 3	I3 (Event input 3)	O3 (Event output 3)	O1 (Event output 1)
Pin No. 4	I4 (Event input 4)	O4 (Event output 4)	O2 (Event output 2)
Pin No. 5	COM	COM	COM

(2) Pin arrangement of serial communication connector

(Upper and lower connectors common)

For serial communication, use the following communication cables (sold separately).

Between host computer or PLC and QMC1-C□

USB communication cable (CMC-001-4) [USB - Modular]

Communication cable (CQM-001) [Y-terminal (C5, 3-wire) - Modular]

Communication cable (CQM-002) [Y-terminal (C4, 5-wire) - Modular]

Between QMC1-C□ and QMC1-C□

Communication cable (CQQ-001) [Modular - Modular]

Pin No.	Model	QMC1-C4□□	QMC1-C5□□
8	8	NC	NC
7	7	SG	SG
6	6	RD(+)	NC
5	5	SD(+)	YB(+)
4	4	SD(-)	YA(-)
3	3	RD(-)	NC
2	2	SG	SG
1	1	NC	NC

7.2.2 Power supply terminal and FG terminal arrangement

The power and FG terminals are located on the base of this instrument. Wiring by the following procedure.

(1) Case removal

- Push the release lever on the top of this instrument to unlock it.
- Remove the case.

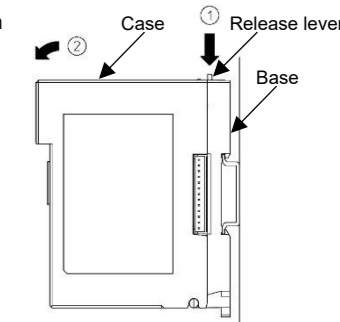

(2) Wiring

### Caution

- Do not use the wrong polarity for the power supply voltage (24 V DC).
- Use copper wires AWG16 to 14 (1.31 to 2.08 mm<sup>2</sup>) for the FG terminal and Power supply terminal.

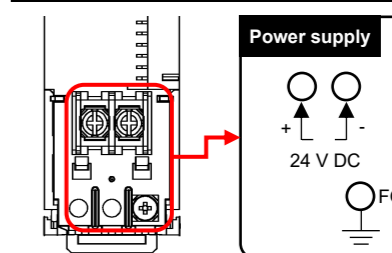

(3) Case mounting

- Hook the case on the lower part ① of this instrument.
- Mount the case so that the lower part ① of this instrument is the fulcrum and covers the release lever. There is a clicking sound.

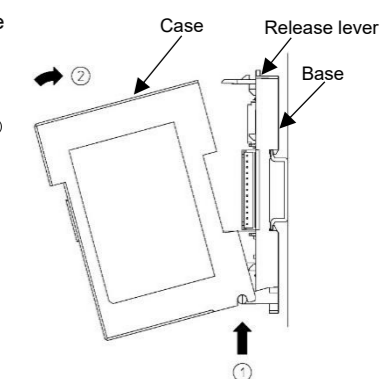

## SHINKO TECHNOS CO., LTD. OVERSEAS DIVISION

Head Office: 2-5-1, Senbahigashi, Minoo, Osaka, 562-0035, Japan  
 [URL] <https://shinko-technos.co.jp/e/> Tel: +81-72-727-6100  
 [E-mail] [overseas@shinko-technos.co.jp](mailto:overseas@shinko-technos.co.jp) Fax: +81-72-727-7006