

和文は裏面をご覧ください。

QUICK REFERENCE [Applicable model: SGH]

Model Name

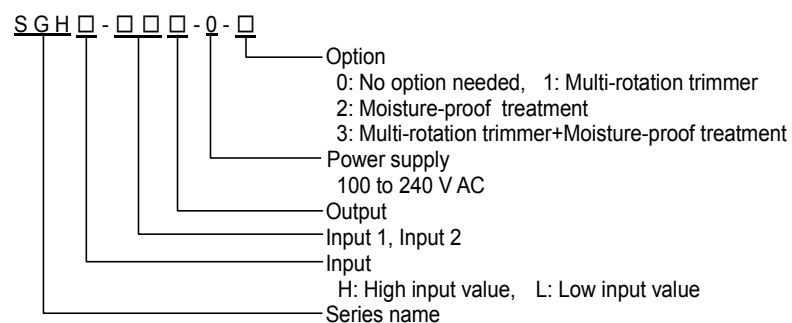

(For detailed input/output spec, refer to the full Instruction Manual.)

Characters

Indication	4	0	1	2	3	4	5	6	7	8	9	C	F
Number, °C/°F	-1	0	1	2	3	4	5	6	7	8	9	°C	°F
Indication	A	B	C	D	E	F	G	H	I	J	K	L	M
Alphabet	A	B	C	D	E	F	G	H	I	J	K	L	M
Indication	N	O	P	Q	R	S	T	U	V	W	X	Y	Z
Alphabet	N	O	P	Q	R	S	T	U	V	W	X	Y	Z

Selection Item List

Input type	Decimal point place
42_A 4 to 20 mA (Built-in 50 Ω shunt resistor)	□ No decimal point
	□□ 1 digit after point
42_1 4 to 20 mA (250 Ω shunt resistor)	□□□ 2 digits after point
	□□□□ 3 digits after point
42_2 4 to 20 mA (50 Ω shunt resistor)	Indication unit
	NONE No unit
020A 0 to 20 mA (250 Ω shunt resistor)	PER %
	MA mA
016A 0 to 16 mA (62.5 Ω shunt resistor)	VOLT V
	CELS °C
210A 2 to 10 mA (250 Ω shunt resistor)	Save settings
	YES Save
	NO Not save
010A 0 to 10 mA (100 Ω shunt resistor)	Output type
15A 1 to 5 mA (100 Ω shunt resistor)	420A 4 to 20 mA
	020A 0 to 20 mA
01A 0 to 1 mA (1000 Ω shunt resistor)	016A 0 to 16 mA
	210A 2 to 10 mA
1050 10 to 50 mA (10 Ω shunt resistor)	010A 0 to 10 mA
	01mV 0 to 10 mV
01mV 0 to 10 mV (Input resi. 1 MΩ)	01V 0 to 1 V
	05V 0 to 5 V
05mV 0 to 50 mV (Input resi. 1 MΩ)	15V 1 to 5 V
	010V 0 to 10 V
06mV 0 to 60 mV (Input resi. 1 MΩ)	-55V -5 to 5 V
	High/Low input value
00V 0 to 100 mV (Input resi. 1 MΩ)	HI GH High input value
	LOW Low input value
01V 0 to 1 V (Input resi. 1 MΩ)	Output Normal/Reverse
05V 0 to 5 V (Input resi. 1 MΩ)	NOML Normal
	REVS Reverse
15V 1 to 5 V (Input resi. 1 MΩ)	Auto/Manual
	AUTO Auto
-55V -5 to 5 V (Input resi. 1 MΩ)	MANU Manual
	(Abbreviation: Input resi.: Input resistance)
010V 0 to 10 V (Input resi. 1 MΩ)	
-10V -10 to 10 V (Input resi. 1 MΩ)	

Terminal Arrangement Circuit Configuration

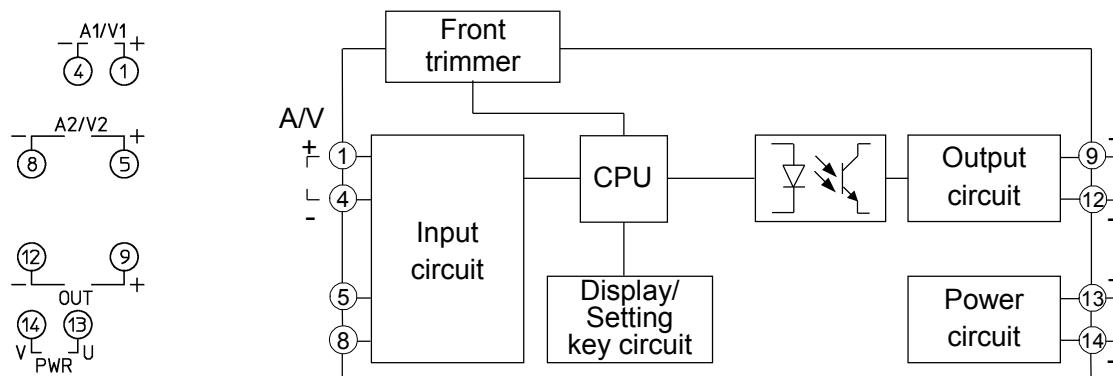

Key Operation Flowchart

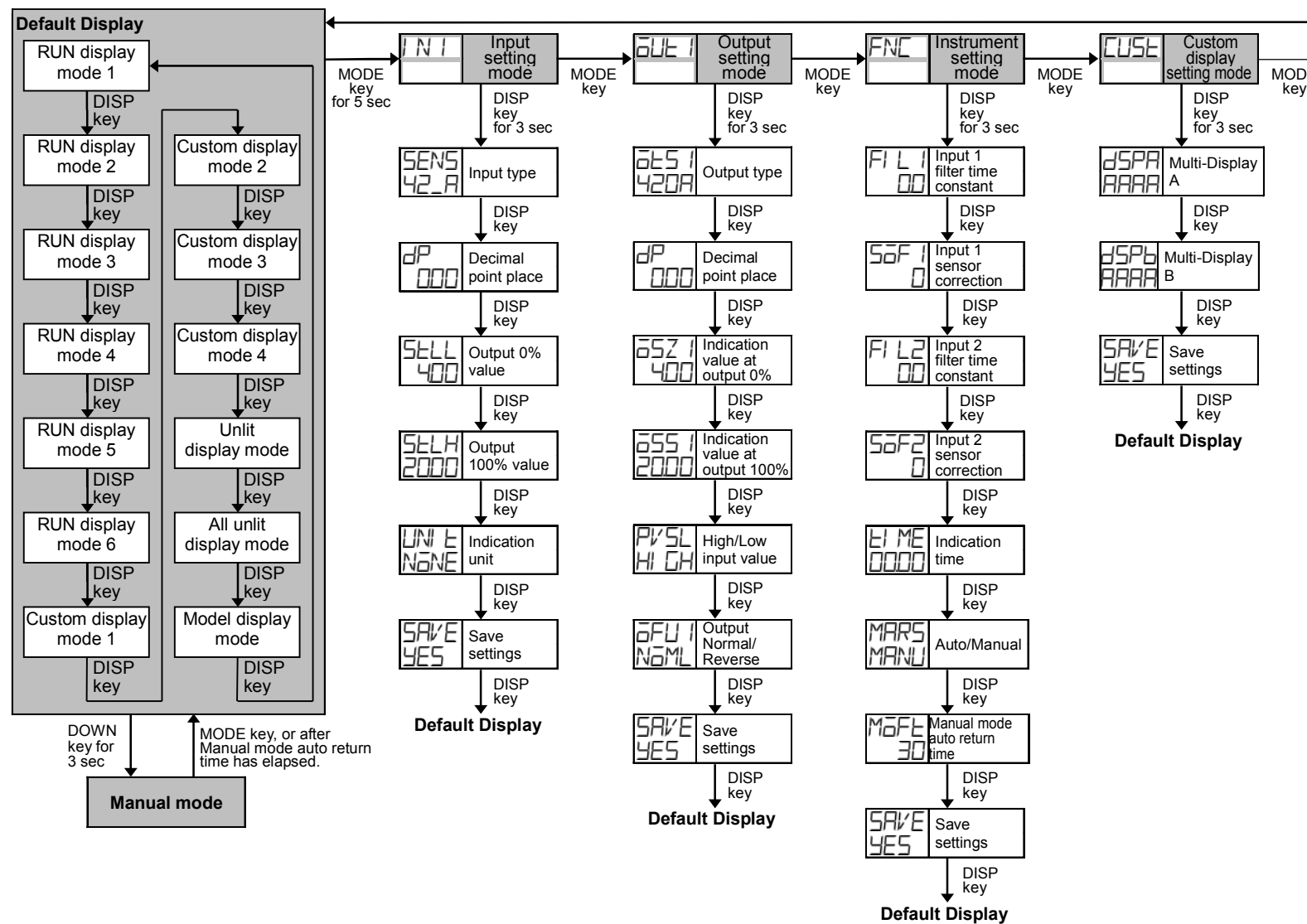

Display Mode

- For the details of the display mode, refer to the full Instruction Manual.

Default Display

- If the MODE and DISP keys (in that order) are pressed together for approx. 3 seconds in any display mode, the display mode will become the Default Display.
- Once the Default Display is set, the DISP key will be in lock status.
- If the DISP key is pressed for approx. 3 seconds, the key lock status will be cancelled.
- If the DISP key is pressed while the DISP key is in lock status, Multi-Display A will indicate LOCK.

Setting Mode

- If the MODE key is pressed for approx. 5 seconds in each setting mode, the unit will move to the Default Display.