

和文は裏面をご覧ください。

# QUICK REFERENCE [Applicable model: SGJ, SGJW, SGJL]

No.SGJ12JE1 2018.10

## Model Name

SGJ □ - F □ □ □ - 0 - □

- Option  
 0: No option needed, 1: Multi-rotation trimmer  
 2: Moisture-proof treatment  
 3: Multi-rotation trimmer+Moisture-proof treatment  
 Power supply  
 100 to 240 V AC  
 Output 2 (For SGJW only)  
 Output 1  
 Input  
 Series name  
 SGJ: 1-output, SGJW: 2-outputs  
 SGJL: 1-output + Serial communication  
 (For detailed input/output spec, refer to the full Instruction Manual.)

## Terminal Arrangement

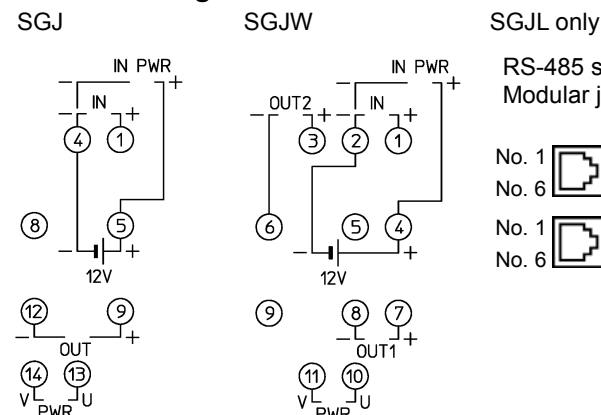

## Circuit Configuration

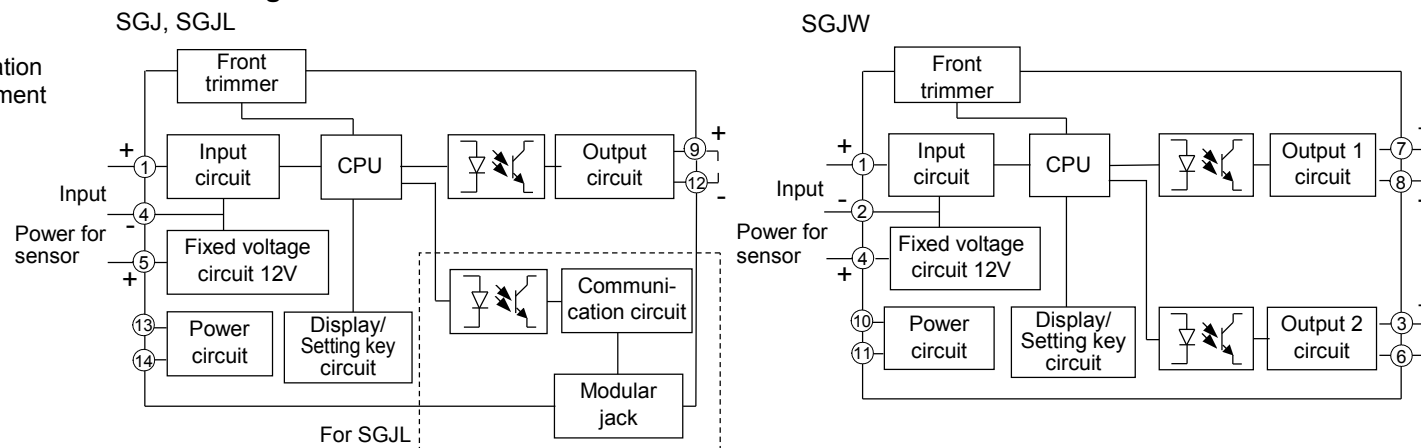

## Characters

Indication	4	0	1	2	3	4	5	6	7	8	9	C	F
Number, °C/°F	-1	0	1	2	3	4	5	6	7	8	9	°C	°F
Indication	A	B	C	D	E	F	G	H	I	J	K	L	M
Alphabet	A	B	C	D	E	F	G	H	I	J	K	L	M
Indication	N	O	P	Q	R	S	T	U	V	W	X	Y	Z
Alphabet	N	O	P	Q	R	S	T	U	V	W	X	Y	Z

## Selection Item List

Frequency range group	Output 1,2 decimal point place
MHZ Ultra-low frequency	No decimal point
HZ Low frequency	1 digit after point
KHZ Frequency	2 digits after point
Decimal point place	3 digits after point
No decimal point	Output 1,2 Normal/Reverse
1 digit after point	Normal
2 digits after point	Reverse
3 digits after point	Auto/Manual
Indication unit	Auto
No unit	Manual
%	Communication speed
mA	96 9600 bps
V	192 19200 bps
°C	384 38400 bps
Save settings	Data bit/Parity
Save	8 bits/No parity
Not save	8 bits/Even
Output 1, Output 2 type	8 bits/Odd
4 to 20 mA	Stop bit
0 to 20 mA	1 bit
0 to 16 mA	2 bits
2 to 10 mA	
0 to 10 mA	
0 to 10 mV	
0 to 100 mV	
0 to 1 V	
0 to 5 V	
1 to 5 V	
0 to 10 V	
-5 to 5 V*1	

\*1 Not available for the SGJW.

## Key Operation Flowchart

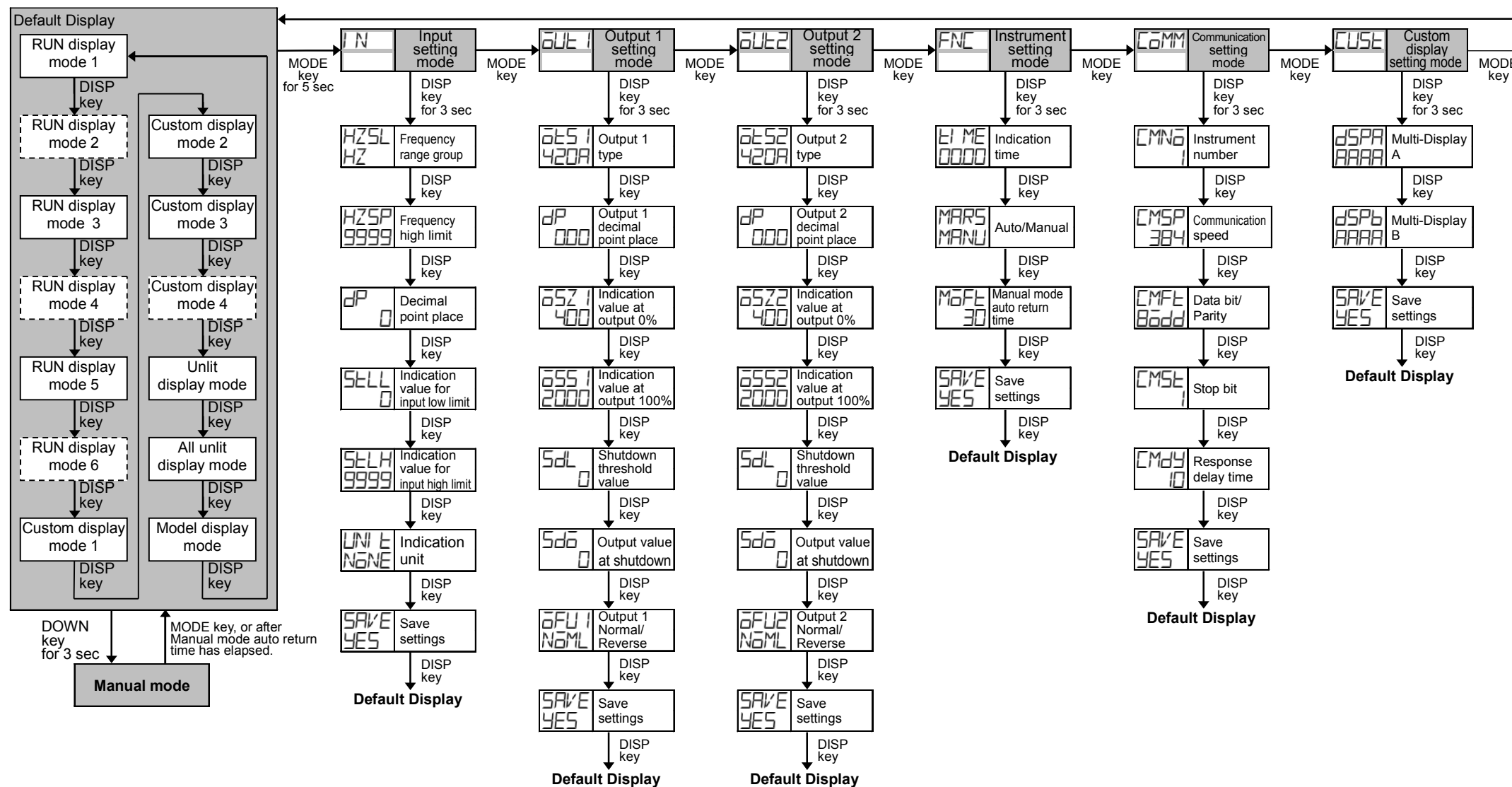

### Display Mode

- Available only for the SGJW.
- For the details of the display mode, refer to the full Instruction Manual.

### Default Display

- If the MODE and DISP keys (in that order) are pressed together for approx. 3 seconds in any display mode, the display mode will become the Default Display.
- Once the Default Display is set, the DISP key will be in lock status.
- If the DISP key is pressed for approx. 3 seconds, the key lock status will be cancelled.
- If the DISP key is pressed while the DISP key is in lock status, Multi-Display A will indicate LOCK.

### Setting Mode

- Output 2 setting mode is available only for the SGJW.
- Communication setting mode is available only for the SGJL.
- If the MODE key is pressed for approx. 5 seconds in each setting mode, the unit will move to the Default Display.