

和文は裏面をご覧ください。

QUICK REFERENCE [Applicable model: SGL, SGLL]

No. SGL12JE1 2018.10

Model Name

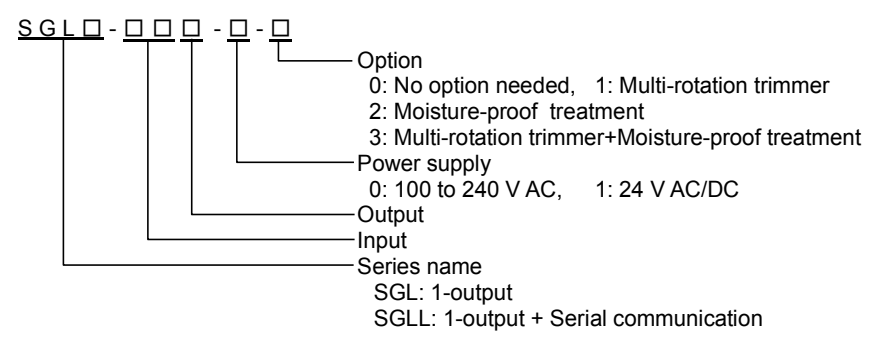

(For detailed input/output spec, refer to the full Instruction Manual.)

Terminal Arrangement

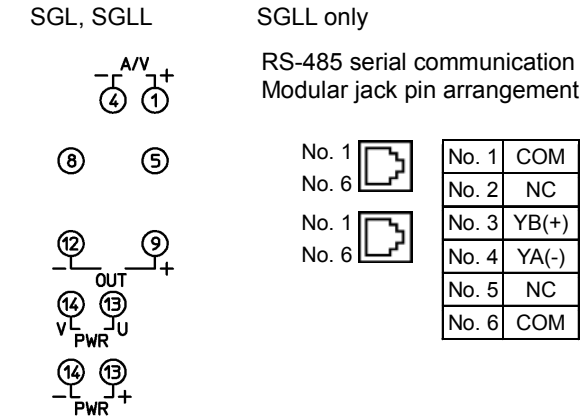

Circuit Configuration

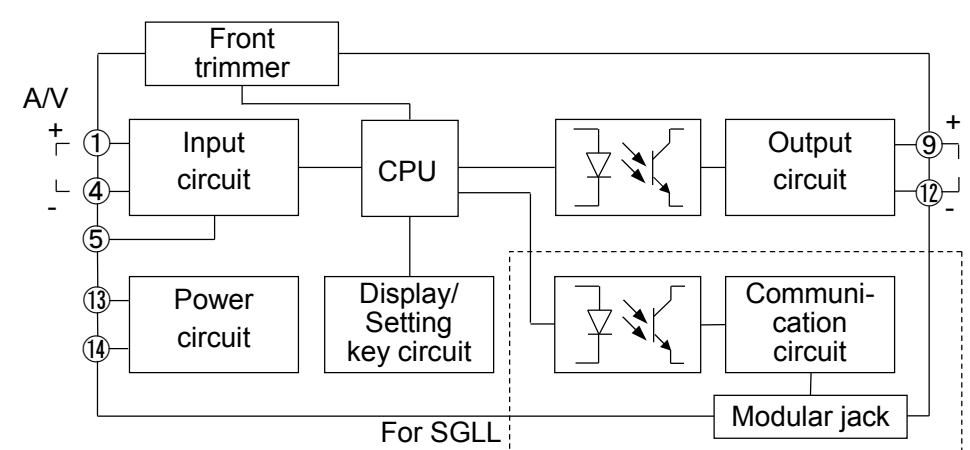

Characters

Indication	4	0	1	2	3	4	5	6	7	8	9	C	F
Number, °C/°F	-1	0	1	2	3	4	5	6	7	8	9	°C	°F
Indication	A	B	C	D	E	F	G	H	I	J	K	L	M
Alphabet	A	B	C	D	E	F	G	H	I	J	K	L	M
Indication	N	O	P	Q	R	S	T	U	V	W	X	Y	Z
Alphabet	N	O	P	Q	R	S	T	U	V	W	X	Y	Z

Selection Item List

Input type	Decimal point place
42_A	4 to 20 mA (Built-in 50 Ω shunt resistor)
42_I	4 to 20 mA (250 Ω shunt resistor)
42_2	4 to 20 mA (50 Ω shunt resistor)
020A	0 to 20 mA (250 Ω shunt resistor)
016A	0 to 16 mA (62.5Ω shunt resistor)
210A	2 to 10 mA (250 Ω shunt resistor)
010A	0 to 10 mA (100 Ω shunt resistor)
15A	1 to 5 mA (100 Ω shunt resistor)
01A	0 to 1 mA (1000Ω shunt resistor)
1050	10 to 50 mA (10 Ω shunt resistor)
01mV	0 to 10 mV (Input resi. 1 MΩ)
05mV	0 to 50 mV (Input resi. 1 MΩ)
06mV	0 to 60 mV (Input resi. 1 MΩ)
00V	0 to 100 mV (Input resi. 1 MΩ)
01V	0 to 1 V (Input resi. 1 MΩ)
05V	0 to 5 V (Input resi. 1 MΩ)
15V	1 to 5 V (Input resi. 1 MΩ)
-55V	-5 to 5 V (Input resi. 1 MΩ)
010V	0 to 10 V (Input resi. 1 MΩ)
-110V	-10 to 10 V (Input resi. 1 MΩ)

Key Operation Flowchart

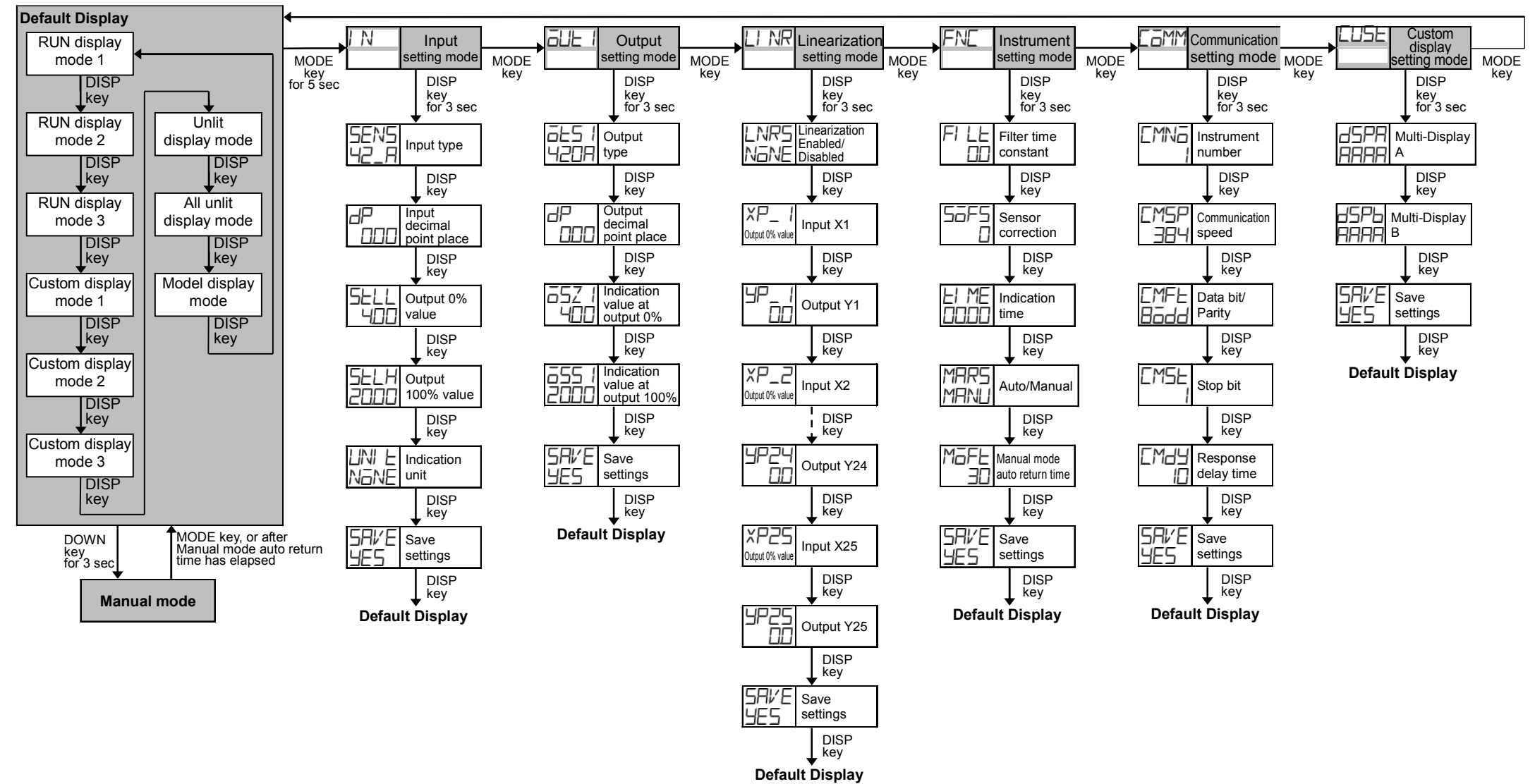

Display Mode

• For the details of the display mode, refer to the full Instruction Manual.

Default Display

- If the MODE and DISP keys (in that order) are pressed together for approx. 3 seconds in any display mode, the display mode will become the Default Display.
- Once the Default Display is set, the DISP key will be in lock status.
- If the DISP key is pressed for approx. 3 seconds, the key lock status will be cancelled.
- If the DISP key is pressed while the DISP key is in lock status, Multi-Display A will indicate **LOCK**.

Setting Mode

- Communication setting mode is available only for the SGLL.
- If the MODE key is pressed for approx. 5 seconds in each setting mode, the unit will move to the Default Display.