

Frequency Transmitter

Model : **SAFU**

(With indication function & sensor power)

Model

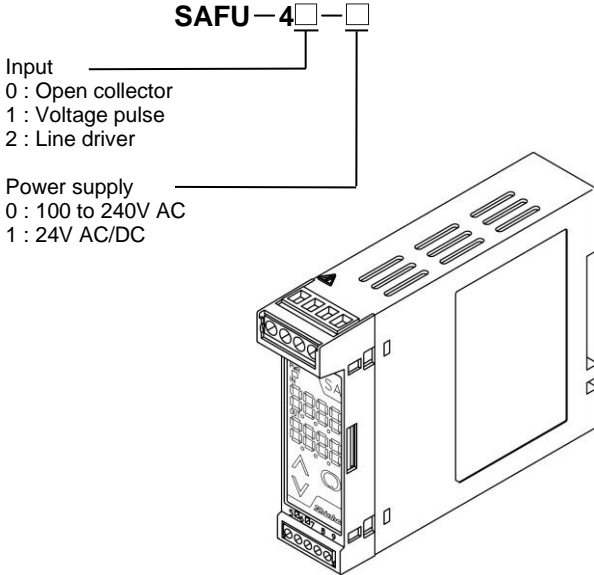

How to order

Specify a model, input frequency, scaling value & Output.
 (e.g.) SAFU-40-0 (Input frequency: 10kHz, Scaling value: 0 to 1000, Output: 1 to 5V DC)

Default value (If not specified, shipped as the following default value)

Input frequency	100kHz
Output	4 to 20mA DC
Scaling value	0 to 9999

Input specifications

Open collector

Frequency range : 0.001Hz to 1kHz
 0.001Hz to 100kHz

Minimum pulse width : 4μs or more (for ON and OFF)

Input detection voltage/current: ON: Max. 30mA (30V or less)
 OFF: Residual voltage 0.5V or less

Operation input conditions : ON: 200Ω or less
 OFF: 100kΩ or more

Voltage pulse

Frequency range : 0.001Hz to 1kHz
 0.001Hz to 100kHz

Minimum pulse width : 4μs or more (for High and Low)

Waveform : Rectangular, sine waveform or similar

Detection level : Low: 1V DC or less
 High: 2V DC or more

Input impedance : 100kΩ or more

Input amplitude : 2 to 50V_{p-p}

Line driver

AM26LS31 or equivalent
 Receiver: AM26LS32 or equivalent
 Terminal resistor : 120Ω

Output Specifications

When the output range lower limit is zero, (even if zero adjustment results in a negative value), the output value will not be negative.

DC Current

Output	Allowable load resistance	Zero adjustment range	Span adjustment range
4 to 20mA DC	700Ω or less	-5 to 5%	95 to 105%
0 to 20mA DC	700Ω or less	0 to 5%	95 to 105%
0 to 12mA DC	1.2kΩ or less	0 to 5%	95 to 105%
0 to 10mA DC	1.2kΩ or less	0 to 5%	95 to 105%
1 to 5mA DC	2.4kΩ or less	-5 to 5%	95 to 105%

DC Voltage

Output	Allowable load resistance	Zero adjustment range	Span adjustment range
0 to 1V DC	100Ω or more	0 to 5%	95 to 105%
0 to 5V DC	500Ω or more	0 to 5%	95 to 105%
1 to 5V DC	500Ω or more	-5 to 5%	95 to 105%
0 to 10V DC	1kΩ or more	0 to 5%	95 to 105%

Performance

Reference accuracy : Within ±0.1% (At 23°C of ambient temperature)

Output accuracy : Within ±0.1%

Display accuracy : Within Reference accuracy ± 1 digit

Frequency sampling period: 500ms

Response time : 700ms + Frequency sampling period or less

Temperature coefficient: ±0.015%/°C

Insulation resistance : 10MΩ or more, at 500V DC
 (Input - Output - Power)

Dielectric strength : 2.0kV AC for 1 minute
 (Input - Output - Power)

General structure

Case : Flame-resistant resin, Color: Light gray

Front panel : Membrane sheet

Setting : By the front keypad

Displays, indicator : Input display:

7-segment, Red LED display 4-digit
 Character size, 7.4 x 4.0mm (H x W)

Output display:

7-segment, Green LED display 4-digit
 Character size, 7.4 x 4.0mm (H x W)

Power indicator: Green LED

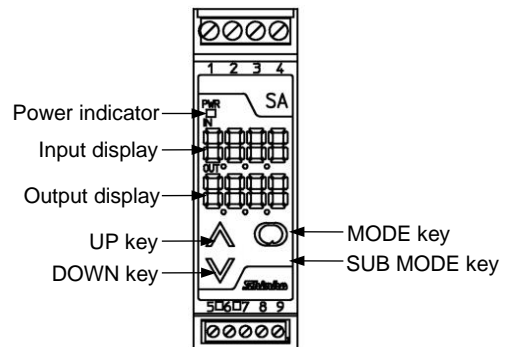

■ Installation specifications

Power supply : 100 to 240V AC, 50/60Hz
 24V AC/DC, 50/60Hz
 Allowable voltage range: 85 to 264V AC
 20 to 28V AC/DC
 Power consumption : Approx. 9VA
 Power supply for sensor: 12V DC ±5%, 25mA
 Ambient temperature : -5 to 55°C (23 to 131°F)
 Ambient humidity : 35 to 85%RH (non-condensing)
 Weight : Approx. 120g
 Mounting : DIN rail mounting
 External dimensions : 22.5 (W) x 75 (H) x 100 (D)mm

■ Attached functions

Power failure countermeasure:
 The data is backed up in non-volatile IC memory.
 Self diagnosis:
 The CPU is monitored by a watchdog timer, and when an abnormal status is found on the CPU, the unit is switched to warm-up status after turning all outputs off.
 Detecting unconnected sensor:
 If pulse is not detected for a constant period (1sec), the unit will revert to the initial status (0Hz).

■ Settings

Function keys

- (1) UP key : Increases the numeric value.
- (2) DOWN key : Decreases the numeric value.
- (3) MODE key : Switches the setting mode.
- (4) SUB MODE key : Press with the MODE key to proceed to the Setup mode.

Setting items

Setting by pressing the MODE key for 3 seconds

- (1) Output zero adjustment
- (2) Output span adjustment

Setting by the MODE key and SUB MODE key

- (1) Set value lock
- (2) Frequency high limit value
- (3) Output 0% value
- (4) Output 100% value
- (5) Decimal point place
- (6) Output type
- (7) Output Normal/Reverse
- (8) Shutdown threshold value
- (9) Output volume during shutdown
- (10) Display selection
- (11) Indication time

■ Displays and indicators

Input display: Indicates the input value.
 Indication of 10000 or more: The lower 4 digits flash.
 0 flashes when pulse is absent.
 When input frequency is lower than shutdown threshold value, the input value flashes.
 Over range: " " flashes on the Input display.
 (1.1 times frequency high limit value)
 Warm-up indication: For approx. 2 seconds after power-on, the input type is indicated on the Input display, and the output type is indicated on the Output display.
 Output display: Indicates the output volume in percentage form (%).
 Power indicator: The green LED lights when power-on.

■ Ferrules

Terminals from 1 to 4

Insulation sleeve attached (Phoenix Contact GMBH & CO.)

AI0.25-8YE	0.2—0.25mm ²
AI0.34-8TQ	0.25—0.34mm ²
AI0.5-8WH	0.34—0.5mm ²
AI0.75-8GY	0.5—0.75mm ²
AI1.0-8RD	0.75—1.0mm ²
AI1.5-8BK	1.0—1.5mm ²

Crimping pliers (Phoenix Contact GMBH & CO.)

CRIMPFOX ZA3
 CRIMPFOX UD6

Terminals from 5 to 9

Insulation sleeve attached (Phoenix Contact GMBH & CO.)

AI0.25-8YE	0.2—0.25mm ²
AI0.34-8TQ	0.25—0.34mm ²
AI0.5-8WH	0.34—0.5mm ²

Crimping pliers (Phoenix Contact GMBH & CO.)

CRIMPFOX ZA3
 CRIMPFOX UD6

■ Circuit configuration and Terminal arrangement

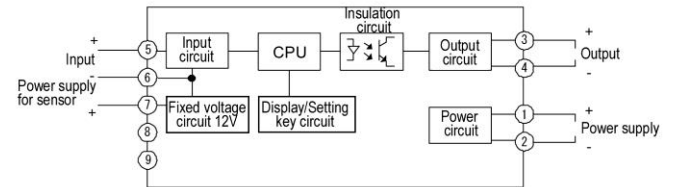

Input connection example

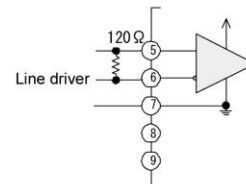
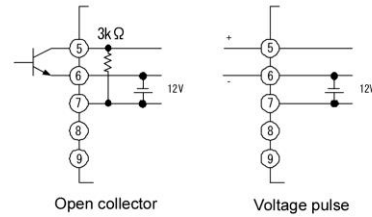

■ External Dimensions (Scale: mm)

