

This manual contains instructions for communication functions of the ACS2.

Serial communication and Console communication cannot be used together.

When performing Serial communication, remove the tool cable (CMD-001) from the USB port of the PC and console connector of the ACS2.

When performing Console communication, it is not required to remove the Serial communication cables.

However, do not send a command from the master side.

# 1. System Configuration

## 1.1 When Using USB Communication Cable CMC-001-1 (sold separately)

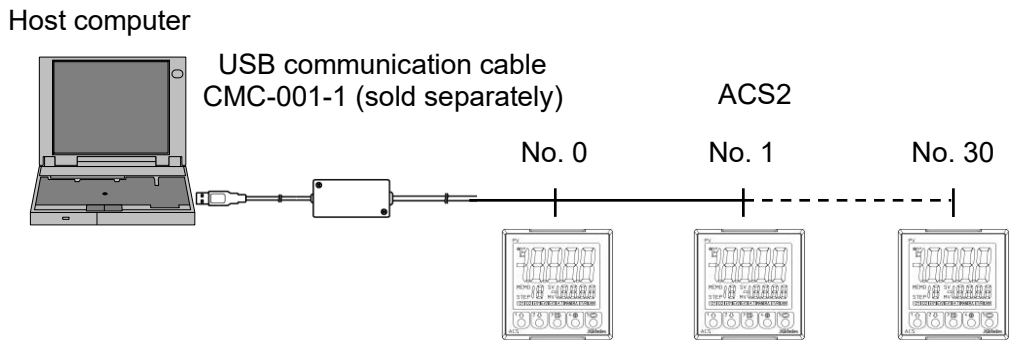

Fig. 1.1-1

## 1.2 When Using Communication Converter IF-400 (sold separately)

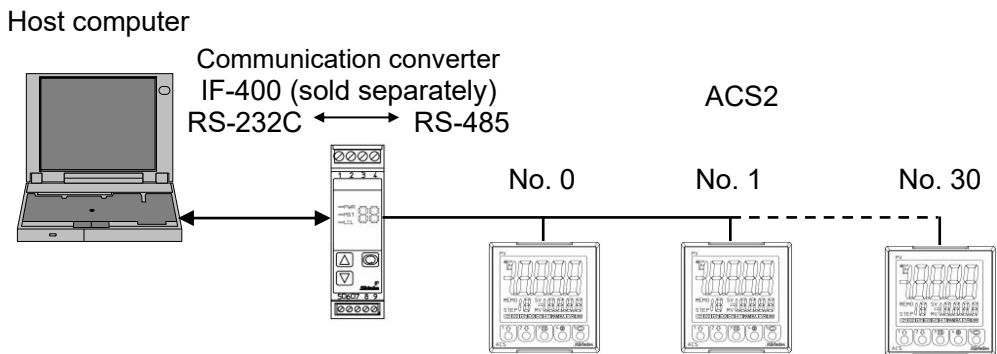

Fig. 1.2-1

## 2. Wiring

### 2.1 When Using USB Communication Cable CMC-001-1 (sold separately)

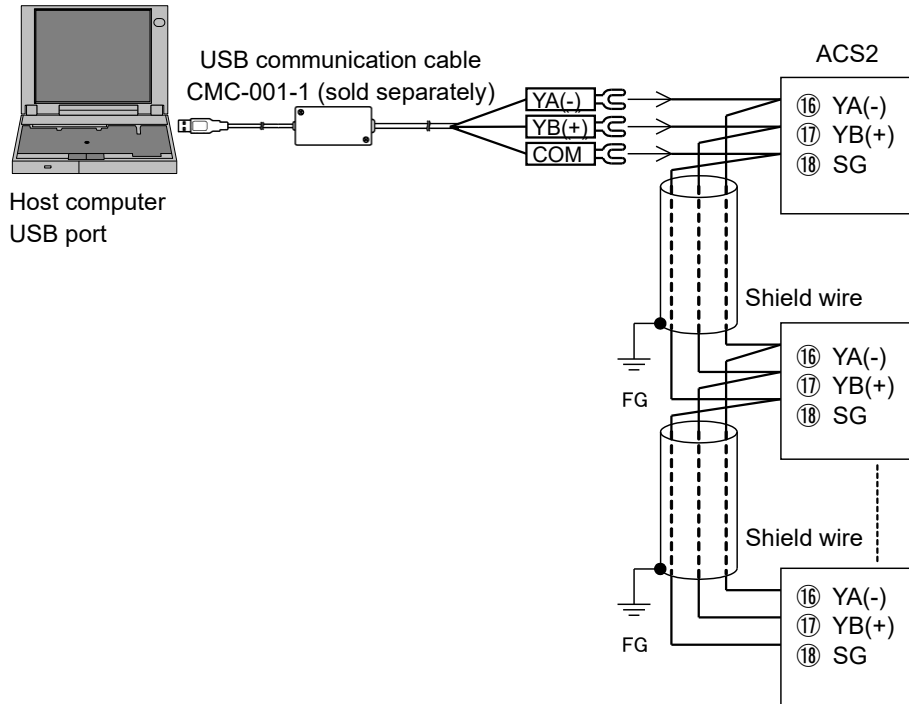

Fig. 2.1-1

### 2.2 When Using Communication Converter IF-400 (sold separately)

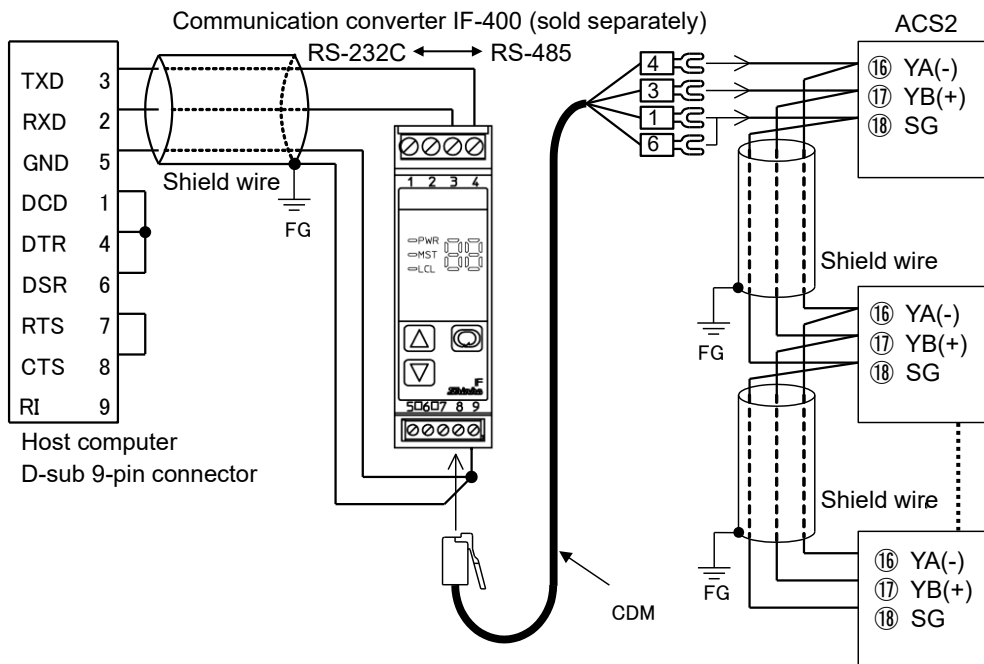

Fig. 2.2-1

**Shield wire**

Connect only one end of the shield to the FG to avoid a ground loop. If both ends of the shield wire are connected to the FG, the circuit will be closed, resulting in a ground loop. This may cause noise. Be sure to ground the FG terminal.

Recommended cable: OTSC-VB 2PX0.5SQ (made by Onamba Co., Ltd.) or equivalent (Use a twisted pair cable.)

**Terminator (Terminal resistor)**





Communication converter IF-400 (sold separately) has a built-in terminator.

The terminator is mounted at the end of the wire when connecting multiple peripheral devices to a personal computer. The terminator prevents signal reflection and disturbance.

Do not connect a terminator to the communication line because ACS2 has built-in pull-up and pull-down resistors.

### 3. Setting Communication Parameters

Set communication parameters in Communication setting group.

To enter Communication setting group, press the  key multiple times in Run mode, then press the  key. Use the  or  key for settings (or making a selection).

To register the set data, use the  key.

Set each communication parameter following the procedure below.

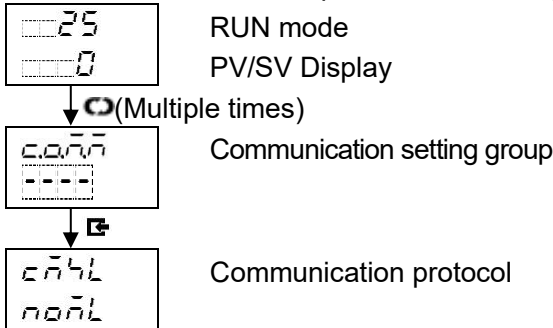

Characters, Factory Default	Setting Item, Function, Setting Range
0000 0000	<b>Communication protocol</b> <ul style="list-style-type: none"> <li>• Selects communication protocol.</li> <li>• Selection item:</li> </ul>
	0000      Shinko protocol
	0001      MODBUS RTU mode
	0002      MC protocol
	0003      SVTC
0000 0000	<b>Instrument number</b> <ul style="list-style-type: none"> <li>• Sets the instrument number.</li> <li>The instrument numbers should be set one by one when multiple instruments are connected in Serial communication, otherwise communication is impossible.</li> <li>• Setting range: 0 to 95</li> </ul>
0000P 0096	<b>Communication speed</b> <ul style="list-style-type: none"> <li>• Selects a communication speed equal to that of the host computer.</li> <li>• Selection item:</li> </ul>
	0096      9600 bps
	0192      19200 bps
	0384      38400 bps
	0576      57600 bps
1152      115200 bps	
0000P 7E8n	<b>Data bit/Parity</b> <ul style="list-style-type: none"> <li>• Selects data bit and parity.</li> <li>• Selection item:</li> </ul>
	8nan      8 bits/No parity
	7nan      7 bits/No parity
	8E8n      8 bits/Even
	7E8n      7 bits/Even
	8odd      8 bits/Odd
7odd      7 bits/Odd	

Characters, Factory Default	Setting Item, Function, Setting Range
274F 0001	<b>Stop bit</b> <ul style="list-style-type: none"> <li>• Selects the stop bit.</li> <li>• Selection item:</li> </ul>
	0001   1 bit
	0002   2 bits
27d9 0000	<b>Response delay time</b> <ul style="list-style-type: none"> <li>• Response from the controller can be delayed after receiving command from the host computer.</li> <li>• Setting range: 0 to 1000 ms</li> </ul>
48.6 0000	<b>SVTC bias</b> <ul style="list-style-type: none"> <li>• Step SV can be received from the connected Shinko programmable controllers PCA1 or PCB1. (Select 'SV digital transmission' in [Communication protocol] on the PCA1 or PCB1.) Refer to Section '9. SV Digital Transmission' on p.73.</li> <li>• SV adds SVTC bias value to the step SV.</li> <li>• Setting range: <math>\pm 20\%</math> of input span DC voltage, current inputs: <math>\pm 20\%</math> of scaling span (*)</li> </ul> Available only when Shinko protocol is selected in [Communication protocol].

(\*): The placement of the decimal point follows the selection.

↓ + (2 times) or (3 sec)

25	RUN mode
0	PV/SV Display

Settings are now complete.

## 4. Communication Procedure

It begins with the host computer sending a command and ends with a response from the controller.

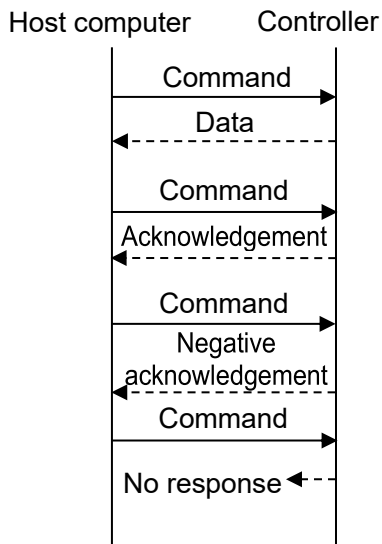

(Fig. 4-1)

### • Response with data

When the master sends the Read command, the slave responds with the corresponding set value or current status.

### • Acknowledgement

When the master sends the Write command, the slave responds by sending the acknowledgement after the processing is terminated.

### • Negative acknowledgement

When the master sends a non-existent command or value out of the setting range, the slave returns a negative acknowledgement.

### • No response

The slave will not respond to the master in the following cases:

- Global address (Shinko protocol) is set.
- Broadcast address (MODBUS RTU mode) is set.
- Communication error (framing error, parity error)
- Checksum error (Shinko protocol), CRC-16 discrepancy (MODBUS RTU mode)

## Communication timing of the RS-485

### Host computer Side (Take note while programming)

When the host computer starts transmission through the RS-485 communication line, the host computer is arranged so as to provide an idle status (mark status) transmission period of 1 or more characters before sending the command to ensure synchronization on the receiving side.

Set the program so that the host computer can disconnect the transmitter from the communication line within a 1 character transmission period after sending the command in preparation for reception of the response from the controller.

To avoid collision of transmissions between the host computer and the controller, send the next command after carefully checking that the host computer has received the response.

If a response to the command is not returned due to communication errors, set the Retry Processing to send the command again. (It is recommended to execute Retry twice or more.)

### Controller Side

When the controller starts transmission through the RS-485 communication line, the controller is arranged so as to provide an idle status (mark status) transmission period of 1 ms or more (\*) before sending the response to ensure synchronization on the receiving side.

The controller is arranged so as to disconnect the transmitter from the communication line within a 1 character transmission period after sending the response.

(\*) Can be set in [Response delay time] within a range of 0 to 1000 ms. (See p.5.)

# 5. Shinko Protocol

## 5.1 Transmission Mode

Shinko protocol is composed of ASCII.

Hexadecimal (0 to 9, A to F), which is divided into high order (4-bit) and low order (4-bit) out of 8-bit binary data in command is transmitted as ASCII characters.

Data format    Start bit:    1 bit  
                          Data bit:    7 bits (8 bits)    Selectable  
                          Parity:        Even (No parity, Odd)    Selectable  
                          Stop bit:    1 bit (2 bits)    Selectable

Error detection: Checksum

## 5.2 Command Configuration

All commands are composed of ASCII.

The data (set value, decimal number) is represented by a hexadecimal number.

The negative numbers are represented in 2's complement.

Numerals written below the command represent number of characters.

### (1) Write command

#### • Write a single piece of data

Header (02H)	Address	Sub address (20H)	Command type (50H)	Data item	Data	Checksum	Delimiter (03H)
1	1	1	1	4	4	2	1

#### • Write multiple pieces of data

Header (02H)	Address	Sub address (20H)	Command type (54H)	Data item	Data	Checksum	Delimiter (03H)
1	1	1	1	4	4 x n	2	1

n: Amount of data

### (2) Read command

#### • Read a single piece of data

Header (02H)	Address	Sub address (20H)	Command type (20H)	Data item	Checksum	Delimiter (03H)
1	1	1	1	4	2	1

#### • Read multiple pieces of data

Header (02H)	Address	Sub address (20H)	Command type (24H)	Data item	Amount of Read data n	Checksum	Delimiter (03H)
1	1	1	1	4	4	2	1

### (3) Response with data

#### • Response to 'Read a single piece of data'

Header (06H)	Address	Sub address (20H)	Command type (20H)	Data item	Data	Checksum	Delimiter (03H)
1	1	1	1	4	4	2	1

#### • Response to 'Read multiple pieces of data'

Header (06H)	Address	Sub address (20H)	Command type (24H)	Data item	Data	Checksum	Delimiter (03H)
1	1	1	1	4	4 x n	2	1

n: Amount of data

#### (4) Acknowledgement

Header (06H)	Address	Checksum	Delimiter (03H)
1	1	2	1

#### (5) Negative acknowledgement

Header (15H)	Address	Error code	Checksum	Delimiter (03H)
1	1	1	2	1

**Header:** Control code to represent the beginning of the command or the response.  
ASCII is used.

Write command, Read command: STX (02H) fixed

Response with data, Acknowledgement: ACK (06H) fixed

Negative acknowledgement: NAK (15H) fixed

**Instrument number (Address):** Numbers by which the host computer discerns each controller.

Instrument number 0 to 94 and Global address 95.

ASCII (20H to 7FH) is used by adding 20H to instrument numbers 0 to 95 (00H to 5FH).

95 (7FH) is called Global address, which is used when the same command is sent to all the controllers connected. However, the response is not returned.

**Sub address:** 20H fixed

**Command type:** Code to discern Write command and Read command.

Command Type	Contents	Description
20H	Read a single piece of data	Reads a single piece of data.
24H	Read multiple pieces of data	Reads consecutive multiple pieces of data. (Amount of data: Max. 100)
50H	Write a single piece of data	Writes a single piece of data.
54H	Write multiple pieces of data	Writes consecutive multiple pieces of data. (Amount of data: Max. 100)

#### Notes about Reading/Writing multiple pieces of data

When reading/writing multiple pieces of data, as it takes time until controller sends response data, the host computer determines no response time based on timeout period below after sending a command.

**Timeout period calculation:** 6 ms x Amount of data + Response delay time (\*)

(\*) Refer to Response delay time on p.5.

**Data item:** Classification of the command object.

Composed of 4-digit hexadecimal numbers, using ASCII.

Refer to '7. Communication Command Table'. (p.21 to 36)

**Data:** The contents of data (values) differ depending on the Write command.

Composed of 4-digit hexadecimal numbers, using ASCII.

Refer to '7. Communication Command Table'. (p.21 to 36)

**Checksum:** 2-character data to detect communication errors.

Refer to '5.3 Checksum Calculation' on p.9.

**Delimiter:** Control code to represent the end of command.

ASCII code ETX (03H) fixed

**Error code:** Represents an error type using ASCII.

Error Code	Contents
1 (31H)	Non-existent command
2 (32H)	Not used
3 (33H)	Value outside the setting range
4 (34H)	Status unable to be written (e.g. AT is performing.)
5 (35H)	During setting mode by keypad operation

### 5.3 Checksum Calculation

Checksum is used to detect receiving errors in the command or data.

Set the program for the master side as well to calculate the checksum of the response data from the slaves so that communication errors can be checked.

The ASCII code (hexadecimal) corresponding to the characters which range from the address to that before the checksum is converted to binary notation, and the total value is calculated.

The lower one byte of the total value is converted to 2's complement, and then to hexadecimal numbers, that is, ASCII code for the checksum.

- 1's complement: Reverse each binary bit. 0 will become 1 and vice versa.
- 2's complement: Add 1 to 1's complement.

#### [Example of checksum calculation]

SV1 (0001H): 600°C (0258H)

Address (instrument number): 0 (20H)

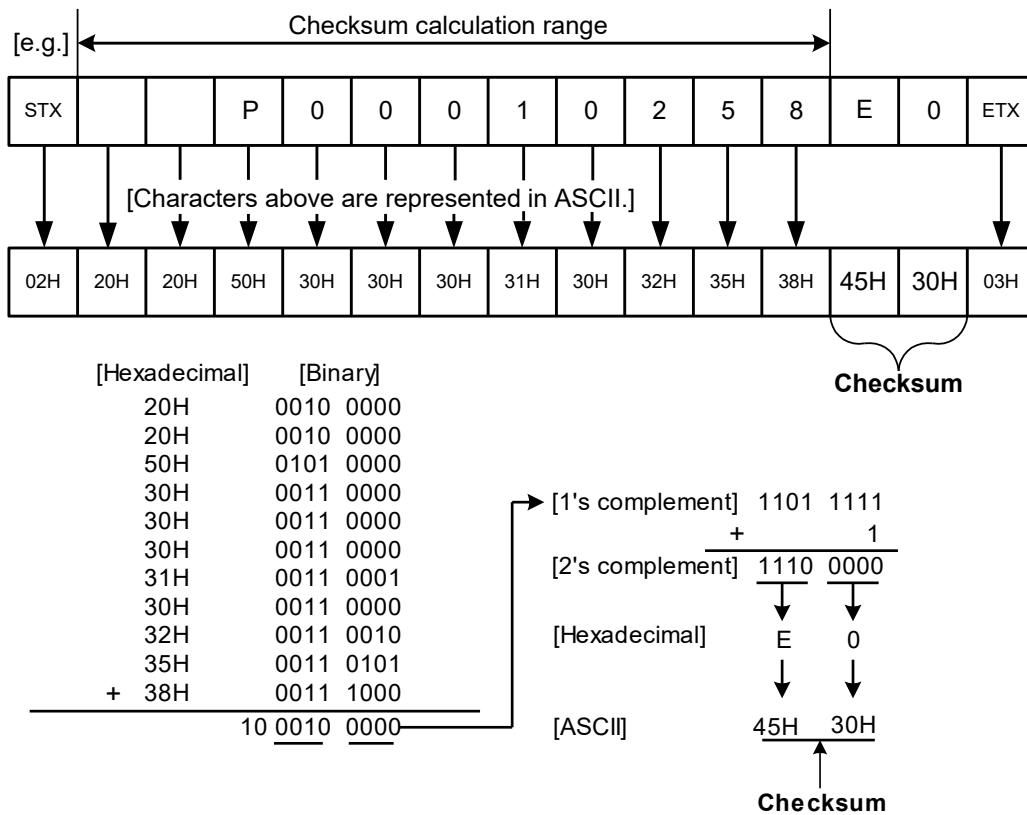

Fig. 5.3-1

## 5.4 Command Example

Numerals written below the command represent number of characters.

### (1) Read [Address 1, PV (03E8H)]

- Read command from the master

Header (02H)	Address (21H)	Sub address (20H)	Command type (20H)	Data item [03E8H] (30H 33H 45H 38H)	Checksum (42H 46H)	Delimiter (03H)
1	1	1	1	4	2	1

- A response from the slave in normal status [When PV=600°C (0258H)]

Header (06H)	Address (21H)	Sub address (20H)	Command type (20H)	Data item [03E8H] (30H 33H 45H 38H)	Data [0258H] (30H 32H 35H 38H)	Checksum (46H 30H)	Delimiter (03H)
1	1	1	1	4	4	2	1

### (2) Write [Address 1, SV1 (0001H)]

- Write command from the master [when writing SV1 to 600°C (0258H)]

Header (02H)	Address (21H)	Sub address (20H)	Command type (50H)	Data item [0001H] (30H 30H 30H 31H)	Data [0258H] (30H 32H 35H 38H)	Checksum (44H 46H)	Delimiter (03H)
1	1	1	1	4	4	2	1

- A response from the slave in normal status

Header (06H)	Address (21H)	Checksum (44H 46H)	Delimiter (03H)
1	1	2	1

### (3) Read [Address 1, SV1 (0001H)]

- Read command from the master

Header (02H)	Address (21H)	Sub address (20H)	Command type (20H)	Data item [0001H] (30H 30H 30H 31H)	Checksum (44H 45H)	Delimiter (03H)
1	1	1	1	4	2	1

- A response from the slave in normal status [When SV1=600°C (0258H)]

Header (06H)	Address (21H)	Sub address (20H)	Command type (20H)	Data item [0001H] (30H 30H 30H 31H)	Data [0258H] (30H 32H 35H 38H)	Checksum (30H 46H)	Delimiter (03H)
1	1	1	1	4	4	2	1

**(4) Write (Address 1, Program pattern data) (Write multiple pieces of data)**

Example of program pattern setting

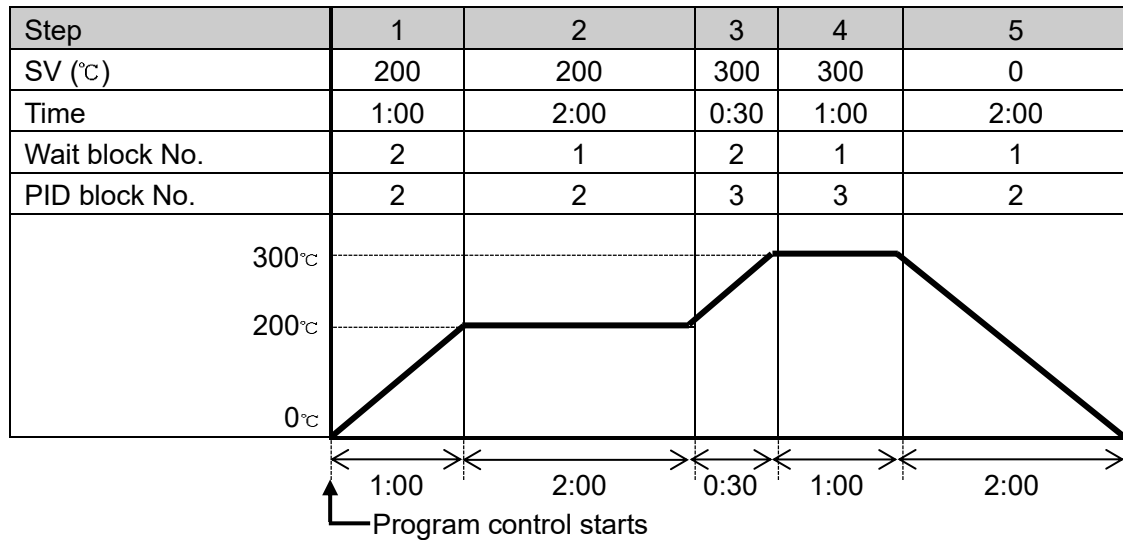

Fig. 5.4-1

When writing the above program pattern, Command data in the message becomes as follows.

Data is converted to hexadecimal.

Data Item		Data	Data (Converted to Hexadecimal)
1000H	Step 1 SV	200 °C	00C8H
1001H	Step 1 time	60 minutes (1:00)	003CH
1002H	Step 1 wait block No.	2	0002H
1003H	Step 1 PID block No.	2	0002H
1004H	Step 2 SV	200 °C	00C8H
1005H	Step 2 time	120 minutes (2:00)	0078H
1006H	Step 2 wait block No.	1	0001H
1007H	Step 2 PID block No.	2	0002H
1008H	Step 3 SV	300 °C	012CH
1009H	Step 3 time	30 minutes (0:30)	001EH
100AH	Step 3 wait block No.	2	0002H
100BH	Step 3 PID block No.	3	0003H
100CH	Step 4 SV	300 °C	012CH
100DH	Step 4 time	60 minutes (1:00)	003CH
100EH	Step 4 wait block No.	1	0001H
100FH	Step 4 PID block No.	3	0003H
1010H	Step 5 SV	0 °C	0000H
1011H	Step 5 time	120 minutes (2:00)	0078H
1012H	Step 5 wait block No.	1	0001H
1013H	Step 5 PID block No.	2	0002H

- Write command from the master (When writing the above program pattern data)

Header (02H)	Address (21H)	Sub address (20H)	Command type (54H)	Data item [1000H] (31H 30H 30H 30H)
1	1	1	1	4

Data
[00C8003C0002000200C8007800010002012C001E00020003012C003C000100030000007800010002H] (30H 30H 43H 38H 30H30H 33H 43H . . . . . 30H 30H 30H 31H 30H 30H 30H 32H)
80 (4 x 15)

Checksum (44H 35H)	Delimiter (03H)
2	1

- Response from the slave in normal status

Header (06H)	Address (21H)	Checksum (44H 46H)	Delimiter (03H)
1	1	2	1

**(5) Read (Address 1, Program pattern data) (Read multiple pieces of data)**

- Read command from the master [Amount of data: 15 (000FH), when reading the program pattern data on p.11]

Header (02H)	Address (21H)	Sub address (20H)	Command type (24H)	Data item [1000H] (31H 30H 30H 30H)	Amount of read data 15 [000FH] (30H 30H 30H 46H)	Checksum (30H 34H)	Delimiter (03H)
1	1	1	1	4	4	2	1

- Response from the slave in normal status

Header (06H)	Address (21H)	Sub address (20H)	Command type (24H)	Data item [1000H] (31H 30H 30H 30H)
1	1	1	1	4

Data
[00C8003C0002000200C8007800010002012C001E00020003012C003C000100030000007800010002H] (30H 30H 43H 38H 30H30H 33H 43H . . . . . 30H 30H 30H 31H 30H 30H 30H 32H)
60 (4 x 15)

Checksum (30H 35H)	Delimiter (03H)
2	1

Response data becomes as follows.

Data Item		Data	Data (Converted to Hexadecimal)
1000H	Step 1 SV	200 °C	00C8H
1001H	Step 1 time	60 minutes (1:00)	003CH
1002H	Step 1 wait block No.	2	0002H
1003H	Step 1 PID block No.	2	0002H
1004H	Step 2 SV	200 °C	00C8H
1005H	Step 2 time	120 minutes (2:00)	0078H
1006H	Step 2 wait block No.	0 °C	0000H
1007H	Step 2 PID block No.	2	0002H
1008H	Step 3 SV	300 °C	012CH
1009H	Step 3 time	30 minutes (0:30)	001EH
100AH	Step 3 wait block No.	10 °C	000AH
100BH	Step 3 PID block No.	3	0003H
100CH	Step 4 SV	300 °C	012CH
100DH	Step 4 time	60 minutes (1:00)	003CH
100EH	Step 4 wait block No.	0 °C	0000H
100FH	Step 4 PID block No.	3	0003H
1010H	Step 5 SV	0 °C	0000H
1011H	Step 5 time	120 minutes (2:00)	0078H
1012H	Step 5 wait block No.	0 °C	0000H
1013H	Step 5 PID block No.	2	0002H

# 6. MODBUS Protocol

## 6.1 Transmission Mode

The MODBUS protocol has one transmission mode (RTU mode). Structurally, RTU mode transmits the 8-bit binary data within the command as-is.

Data format    Start bit:    1 bit  
                  Data bit:    8 bits  
                  Parity:      No parity (Even, Odd) (Selectable)  
                  Stop bit:    1 bit (2 bits) (Selectable)  
Error detection: CRC-16 (Cyclic Redundancy Check)

## 6.2 Data Communication Interval

1.5 character transmission times or less

(Communication speed 9600 bps: 1.5 character transmission times,

Communication speed 19200 bps, 38400 bps, 57600 bps and 115200 bps: 750  $\mu$ s)

To transmit continuously, an interval between characters which consist of one message, must be within 1.5 character transmission times.

If an interval lasts longer than 1.5 character transmission times, from the master is finished, which results in a communication error, and will not return a response.

## 6.3 Message Configuration

RTU mode message is configured to start after idle time is processed for more than 3.5 character transmissions, and end after idle time is processed for more than 3.5 character transmissions.

(Communication speed 9600 bps: 3.5 character transmission times,

Communication speed 19200 bps, 38400 bps, 57600 bps, and 115200 bps: 1.75 ms)

Data section: Max. 252 bytes

3.5 idle characters	Slave address	Function code	Data	Error check CRC-16	3.5 idle characters
---------------------	---------------	---------------	------	-----------------------	---------------------

### (1) Slave Address

Slave address is an individual instrument number on the slave side, and is set within the range 0 to 95 (00H to 5FH). The master identifies slaves by the slave address of the requested message.

The slave informs the master which slave is responding to the master by placing its own address in the response message.

Slave address 0 (00H, Broadcast address) can identify all the slaves connected. However, slaves do not respond.

### (2) Function Code

The function code is the command code for the slave to undertake one of the following actions.

Type	Function Code	Sub-Function Code	Contents
Data access	03 (03H)		Reads a single or multiple piece(s) of data from slave(s).
	06 (06H)		Writes a single piece of data to slave(s).
	16 (10H)		Writes multiple pieces of data to slave(s).

The function code is used to discern whether the response is normal (acknowledgement) or if any error (negative acknowledgement) has occurred when the slave returns the response message to the master.

When acknowledgement is returned, the slave simply returns the original function code.

When negative acknowledgement is returned, the MSB of the original function code is set as 1 for the response.

For example, if the master sends request message setting 13H to the function code by mistake, slave returns 93H by setting the MSB to 1, because the former is an illegal function.

For negative acknowledgement, the exception codes below are set to the data of the response message, and returned to the master in order to inform it of what kind of error has occurred.

Exception Code	Contents
1 (01H)	Illegal function (Non-existent function)
2 (02H)	Illegal data address (Non-existent data address)
3 (03H)	Illegal data value (Value out of the setting range)
17 (11H)	Shinko protocol error code 4 (Status unable to be written. (e.g.) AT is performing.)
18 (12H)	Shinko protocol error code 5 (During setting mode by keypad operation)

### (3) Data

Data differs depending on the function code.

A request message from the master is composed of a data item, amount of data and setting data.

A response message from the slave is composed of the byte count, data and exception codes in negative acknowledgements, corresponding to the request message.

The effective range of data is -32768 to 32767 (8000H to 7FFFH).

Refer to Section "7. Communication Command Table" (p.21 to 36).

#### (4) Error Check

After calculating CRC-16 (Cyclic Redundancy Check) from the slave address to the end of the data, the calculated 16-bit data is appended to the end of message in sequence from low order to high order.

##### How to calculate CRC-16

In the CRC-16 system, the information is divided by the polynomial series. The remainder is added to the end of the information and transmitted. The generation of a polynomial series is as follows.

(Generation of polynomial series:  $X^{16} + X^{15} + X^2 + 1$ )

- ① Initialize the CRC-16 data (assumed as X) (FFFFH).
- ② Calculate exclusive OR (XOR) with the 1st data and X. This is assumed as X.
- ③ Shift X one bit to the right. This is assumed as X.
- ④ When a carry is generated as a result of the shift, XOR is calculated by X of ③ and the fixed value (A001H). This is assumed as X. If a carry is not generated, go to step ⑤.
- ⑤ Repeat steps ③ and ④ until shifting 8 times.
- ⑥ XOR is calculated with the next data and X. This is assumed as X.
- ⑦ Repeat steps ③ to ⑤.
- ⑧ Repeat steps ③ to ⑤ up to the final data.
- ⑨ Set X as CRC-16 to the end of message in sequence from low order to high order.

## 6.4 Message Example

Numerals written below the command represent number of characters.

### (1) Read [Slave address 1, PV (03E8H)]

- A request message from the master

3.5 idle characters	Slave address (01H)	Function code (03H)	Data item (03E8H)	Amount of data (0001H)	Error check CRC-16 (047AH)	3.5 idle characters
	1	1	2	2	2	

- Response message from the slave in normal status [When PV is 600°C (0258H)]

3.5 idle characters	Slave address (01H)	Function code (03H)	Response byte count (02H)	Data (0258H)	Error check CRC-16 (B8DEH)	3.5 idle characters
	1	1	1	2	2	

### (2) Write [Slave address 1, SV1 (0001H)]

- A request message from the master [When SV1 is written to 600°C (0258H)]

3.5 idle characters	Slave address (01H)	Function code (06H)	Data item (0001H)	Data (0258H)	Error check CRC-16 (D890H)	3.5 idle characters
	1	1	2	2	2	

- Response message from the slave in normal status

3.5 idle characters	Slave address (01H)	Function code (06H)	Data item (0001H)	Data (0258H)	Error check CRC-16 (D890H)	3.5 idle characters
	1	1	2	2	2	

- Response message from the slave in exception (error) status (When a value out of the setting range is set)  
The function code MSB is set to 1 for the response message in exception (error) status, and 86H is returned.  
The Exception code 03H (Value out of the setting range) is returned (error).

3.5 idle characters	Slave address (01H)	Function code (86H)	Exception code (03H)	Error check CRC-16 (0261H)	3.5 idle characters
	1	1	1	2	

### (3) Read [Slave address 1, SV1 (0001H)]

- A request message from the master

3.5 idle characters	Slave address (01H)	Function code (03H)	Data item (0001H)	Data (0001H)	Error check CRC-16 (D5CAH)	3.5 idle characters
	1	1	2	2	2	

- Response message from the slave in normal status [When SV1 is 600°C (0258H)]

3.5 idle characters	Slave address (01H)	Function code (03H)	Response byte count (02H)	Data (0258H)	Error check CRC-16 (B8DEH)	3.5 idle characters
	1	1	1	2	2	

- Response message from the slave in exception (error) status (When data item is incorrect)  
The function code MSB is set to 1 for the response message in exception (error) status, and 83H is returned. The Exception code 02H (Non-existent data address) is returned (error).

3.5 idle characters	Slave address (01H)	Function code (83H)	Exception code (02H)	Error check CRC-16 (C0F1H)	3.5 idle characters
	1	1	1	2	

**(4) Write (Slave address 1, Program pattern data) (Write multiple pieces of data)**

Program pattern setting example

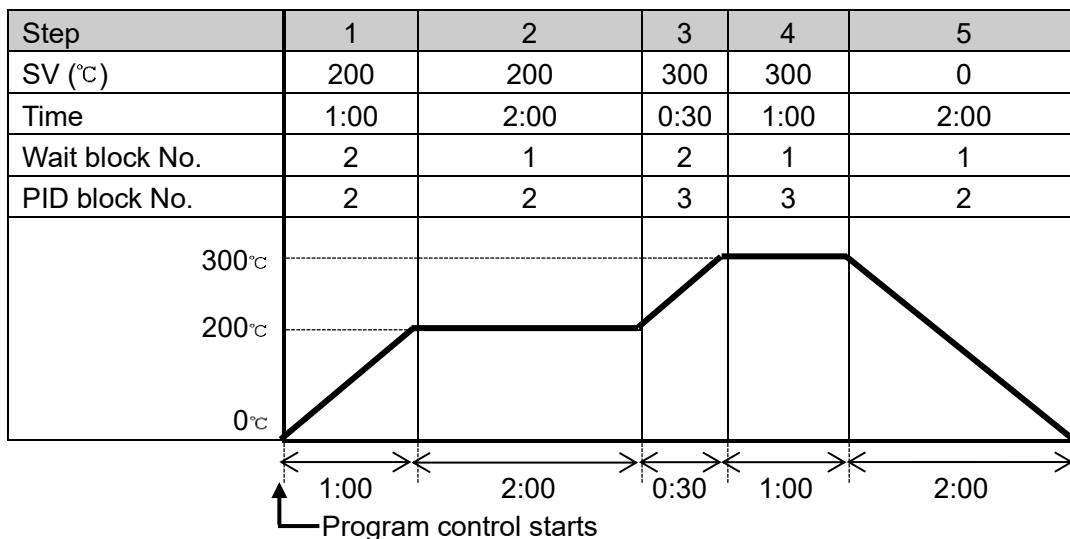

Fig. 6.4.2-1

When writing the above program pattern, Data in the message becomes as follows.

Amount of data: 20 (0014H)

Byte count: 40 (28H)

Data is converted to hexadecimal.

Data Item		Data	Data (Converted to Hexadecimal)
1000H	Step 1 SV	200 °C	00C8H
1001H	Step 1 time	60 minutes (1:00)	003CH
1002H	Step 1 wait block No.	2	0002H
1003H	Step 1 PID block No.	2	0002H
1004H	Step 2 SV	200 °C	00C8H
1005H	Step 2 time	120 minutes (2:00)	0078H
1006H	Step 2 wait block No.	1	0001H
1007H	Step 2 PID block No.	2	0002H
1008H	Step 3 SV	300 °C	012CH
1009H	Step 3 time	30 minutes (0:30)	001EH
100AH	Step 3 wait block No.	2	0002H
100BH	Step 3 PID block No.	3	0003H
100CH	Step 4 SV	300 °C	012CH
100DH	Step 4 time	60 minutes (1:00)	003CH
100EH	Step 4 wait block No.	1	0001H
100FH	Step 4 PID block No.	3	0003H
1010H	Step 5 SV	0 °C	0000H
1011H	Step 5 time	120 minutes (2:00)	0078H
1012H	Step 5 wait block No.	1	0001H
1013H	Step 5 PID block No.	2	0002H

- A request message from the master (When writing the above program pattern data)

3.5 idle characters	Slave address (01H)	Function code (10H)	Data item (1000H)
	1	1	2

Data
(00142800C8003C0002000200C8007800010002012C001E00020003012C003C000100030000007800010002H)
43

Error check CRC-16 (98AAH)	3.5 idle characters
2	

- Response message from the slave in normal status

3.5 idle characters	Slave address (01H)	Function code (10H)	Data item (1000H)	Data (0014H)	Error check CRC-16 (C4C6H)	3.5 idle characters
	1	1	2	2	2	

**(5) Read (Slave address 1, Program pattern data) (Read multiple pieces of data)**

- A request message from the master (When reading the program pattern data on p.20)

3.5 idle characters	Slave address (01H)	Function code (03H)	Data item (1000H)	Amount of data (0014H)	Error check CRC-16 (4105H)	3.5 idle characters
	1	1	2	2	2	

- Response message from the slave in normal status

3.5 idle characters	Slave address (01H)	Function code (03H)	Response byte count (28H)
	1	1	1

Data
(00C8003C0002000200C8007800010002012C001E00020003012C003C000100030000007800010002H)

40

Error check CRC-16 (17A4H)	3.5 idle characters
2	

Data in the response message becomes as follows.

	Data Item	Data	Data (Converted to Hexadecimal)
1000H	Step 1 SV	200 °C	00C8H
1001H	Step 1 time	60 minutes (1:00)	003CH
1002H	Step 1 wait block No.	2	0002H
1003H	Step 1 PID block No.	2	0002H
1004H	Step 2 SV	200 °C	00C8H
1005H	Step 2 time	120 minutes (2:00)	0078H
1006H	Step 2 wait block No.	1	0001H
1007H	Step 2 PID block No.	2	0002H
1008H	Step 3 SV	300 °C	012CH
1009H	Step 3 time	30 minutes (0:30)	001EH
100AH	Step 3 wait block No.	2	0002H
100BH	Step 3 PID block No.	3	0003H
100CH	Step 4 SV	300 °C	012CH
100DH	Step 4 time	60 minutes (1:00)	003CH
100EH	Step 4 wait block No.	1	0001H
100FH	Step 4 PID block No.	3	0003H
1010H	Step 5 SV	0 °C	0000H
1011H	Step 5 time	120 minutes (2:00)	0078H
1012H	Step 5 wait block No.	1	0001H
1013H	Step 5 PID block No.	2	0002H

# 7. Communication Command Table

## 7.1 Shinko Protocol / MODBUS RTU

### 7.1.1 Setting Value Read/Write Command

Shinko Protocol Command Type	MODBUS Function Code	Data Item		Data
20/24/50/54H	03/06/10H	0001H	SV1 setting	Set value (Decimal point ignored)
20/24/50/54H	03/06/10H	0002H	SV2 setting	Set value (Decimal point ignored)
20/24/50/54H	03/06/10H	0003H	SV3 setting	Set value (Decimal point ignored)
20/24/50/54H	03/06/10H	0004H	SV4 setting	Set value (Decimal point ignored)
20/24/50/54H	03/06/10H	0005H	SV5 setting	Set value (Decimal point ignored)
20/24/50/54H	03/06/10H	0006H	SV6 setting	Set value (Decimal point ignored)
20/24/50/54H	03/06/10H	0007H	SV7 setting	Set value (Decimal point ignored)
20/24/50/54H	03/06/10H	0008H	SV8 setting	Set value (Decimal point ignored)
		0009H to 001FH	Reserved (*1)  Reserved (*1)	
20/24/50/54H	03/06/10H	0020H	Input type selection	0000H : K -200 to 1370 °C 0001H : K -200.0 to 800.0 °C 0002H : K -200.0 to 400.0 °C 0003H : J -200 to 1000 °C 0004H : J -200.0 to 400.0 °C 0005H : R 0 to 1760 °C 0006H : S 0 to 1760 °C 0007H : B 0 to 1820 °C 0008H : E -200 to 800 °C 0009H : T -200.0 to 400.0 °C 000AH : N -200 to 1300 °C 000BH : PL-II 0 to 1390 °C 000CH : C(W/Re5-26) 0 to 2315 °C 000DH : Pt100 -200.0 to 850.0 °C 000EH : Pt100 -200 to 850 °C 000FH : Pt100 -100.0 to 100.0 °C 0010H : 4 to 20mA DC -19999 to 19999 Built-in shunt resistor 0011H : 0 to 20mA DC -19999 to 19999 Built-in shunt resistor 0012H : 4 to 20mA DC-19999 to 19999 External shunt resistor 0013H : 0 to 20mA DC -19999 to 19999 External shunt resistor 0014H : 0 to 1V DC -19999 to 19999 0015H : 0 to 5V DC -19999 to 19999 0016H : 1 to 5V DC -19999 to 19999 0017H : 0 to 10V DC -19999 to 19999
20/24/50/54H	03/06/10H	0021H	Temperature unit selection	0000H: Celsius 0001H: Fahrenheit
20/24/50/54H	03/06/10H	0022H	Scaling high limit setting	Set value (Decimal point ignored)
20/24/50/54H	03/06/10H	0023H	Scaling low limit setting	Set value (Decimal point ignored)

Shinko Protocol Command Type	MODBUS Function Code	Data Item		Data
20/24/50/54H	03/06/10H	0024H	Decimal point position selection	0000H: No decimal point 0001H: 1 digit after decimal point 0002H: 2 digits after decimal point 0003H: 3 digits after decimal point 0004H: 4 digits after decimal point
20/24/50/54H	03/06/10H	0025H	Input sampling selection	0000H :125 msec 0001H :50 msec 0002H :10 msec
20/24/50/54H	03/06/10H	0026H	Number of moving average	Set value
20/24/50/54H	03/06/10H	0027H	Sensor correction coefficient setting	Set value (Decimal point ignored)
20/24/50/54H	03/06/10H	0028H	Sensor correction setting	Set value (Decimal point ignored)
20/24/50/54H	03/06/10H	0029H	PV filter time constant setting	Set value (Decimal point ignored)
		002AH to 002FH	Reserved (*1) to Reserved (*1)	
20/24/50/54H	03/06/10H	0030H	OUT1 output type selection	0000H :SSR 0001H : Current output (4-20 mA DC) 0002H : Current output (0-20mA DC)
20/24/50/54H	03/06/10H	0031H	OUT1 proportional cycle setting	Set value (Decimal point ignored)
20/24/50/54H	03/06/10H	0032H	OUT1 ON/OFF hysteresis setting	Set value (Decimal point ignored)
20/24/50/54H	03/06/10H	0033H	OUT1 high limit setting	Set value (Decimal point ignored)
20/24/50/54H	03/06/10H	0034H	OUT1 low limit setting	Set value (Decimal point ignored)
20/24/50/54H	03/06/10H	0035H	OUT1 rate of change limit setting	Set value (Decimal point ignored)
20/24/50/54H	03/06/10H	0036H	OUT2 output type selection	0000H :SSR 0001H : Current output (4-20 mA DC) 0002H : Current output (0-20mA DC)
20/24/50/54H	03/06/10H	0037H	OUT2 cooling method selection	0000H : Air cooling 0001H : Oil cooling 0002H : Water cooling
20/24/50/54H	03/06/10H	0038H	OUT2 proportional cycle setting	Set value (Decimal point ignored)
20/24/50/54H	03/06/10H	0039H	OUT2 ON/OFF hysteresis setting	Set value (Decimal point ignored)
20/24/50/54H	03/06/10H	003AH	OUT2 high limit setting	Set value (Decimal point ignored)
20/24/50/54H	03/06/10H	003BH	OUT2 low limit setting	Set value (Decimal point ignored)
20/24/50/54H	03/06/10H	003CH	Direct/Reverse action selection	0000H : Reverse action 0001H : Direct action
20/24/50/54H	03/06/10H	003DH	Pre-set output setting 1	Set value (Decimal point ignored)
20/24/50/54H	03/06/10H	003EH	Pre-set output setting 2	Set value (Decimal point ignored)
20/24/50/54H	03/06/10H	003FH	Action selection when input errors occur	0000H: Action selection when input errors occur 0001H : Control operation continues
20/24/50/54H	03/06/10H	0040H	Reserved (*1)	
20/24/50/54H	03/06/10H	0041H	OUT1 MV setting when input errors occur	Set value (Decimal point ignored)
20/24/50/54H	03/06/10H	0042H	OUT2 MV setting when input errors occur	Set value (Decimal point ignored)
		0043H to 004FH	Reserved (*1) to Reserved (*1)	
20/24/50/54H	03/06/10H	0050H	Event output EV1 allocation setting (*2)	0000H : No event 0001H : High limit alarm 0002H : Low limit alarm 0003H : High/Low limits alarm

Shinko Protocol Command Type	MODBUS Function Code	Data Item		Data
				0004H : High/Low limits independent alarm 0005H : High/Low limit range alarm 0006H : High/Low limit range independent alarm 0007H : Process high alarm 0008H : Process low alarm 0009H : High limit with standby alarm 000AH : Low limit with standby alarm 000BH : High/Low limits with standby alarm 000CH : High/Low limits with standby independent alarm 000DH : Heater burnout alarm 000EH : Loop break alarm 000FH : Time signal output 0010H : Output during AT 0011H : Pattern end output 0012H : Output by communication command 0013H : Output when error occurs
20/24/50/54H	03/06/10H	0051H	EV1 enabled/disabled selection when alarm sets 0	0000H : Disabled 0001H : Enabled
20/24/50/54H	03/06/10H	0052H	EV1 hysteresis setting	Set value (Decimal point ignored)
20/24/50/54H	03/06/10H	0053H	EV1 action delay timer setting	Set value
20/24/50/54H	03/06/10H	0054H	EV1 action Energized/De-energized setting	0 : Energized 1 : De-energized
20/24/50/54H	03/06/10H	0055H	EV1 output latch selection	0 : Disabled 1 : Enabled
20/24/50/54H	03/06/10H	0056H	TS1 output step number	Set value
20/24/50/54H	03/06/10H	0057H	TS1 OFF time setting	Set value
20/24/50/54H	03/06/10H	0058H	TS1 ON time setting	Set value
20/24/50/54H	03/06/10H	0059H	Event output EV2 allocation setting (*2)	0000H : No event 0001H : High limit alarm 0002H : Low limit alarm 0003H : High/Low limits alarm 0004H : High/Low limits independent alarm 0005H : High/Low limit range alarm 0006H : High/Low limit range independent alarm 0007H : Process high alarm 0008H : Process low alarm 0009H : High limit with standby alarm 000AH : Low limit with standby alarm 000BH : High/Low limits with standby alarm 000CH : High/Low limits with standby independent alarm 000DH : Heater burnout alarm 000EH : Loop break alarm 000FH : Time signal output 0010H : Output during AT 0011H : Pattern end output 0012H : Output by communication command 0013H : Output when error occurs

Shinko Protocol Command Type	MODBUS Function Code	Data Item		Data
				0014H : Main output
				0015H : Cooling output
20/24/50/54H	03/06/10H	005AH	EV2 enabled/disabled selection when alarm sets 0	0000H : Disabled 0001H : Enabled
20/24/50/54H	03/06/10H	005BH	EV2 hysteresis setting	Set value (Decimal point ignored)
20/24/50/54H	03/06/10H	005CH	EV2 action delay timer setting	Set value
20/24/50/54H	03/06/10H	005DH	EV2 action Energized/De-energized setting	0 : Energized 1 : De-energized
20/24/50/54H	03/06/10H	005EH	EV2 output latch selection	0 : Disabled 1 : Enabled
20/24/50/54H	03/06/10H	005FH	TS2 output step number	Set value
20/24/50/54H	03/06/10H	0060H	TS2 OFF time setting	Set value
20/24/50/54H	03/06/10H	0061H	TS2 ON time setting	Set value
20/24/50/54H	03/06/10H	0062H	Event output EV3 allocation setting (*2)	Same as Event output EV1 allocation setting
20/24/50/54H	03/06/10H	0063H	EV3 enabled/disabled selection when alarm sets 0	0000H : Disabled 0001H : Enabled
20/24/50/54H	03/06/10H	0064H	EV3 hysteresis setting	Set value (Decimal point ignored)
20/24/50/54H	03/06/10H	0065H	EV3 action delay timer setting	Set value
20/24/50/54H	03/06/10H	0066H	EV3 action Energized/De-energized setting	0 : Energized 1 : De-energized
20/24/50/54H	03/06/10H	0067H	EV3 output latch selection	0 : Disabled 1 : Enabled
20/24/50/54H	03/06/10H	0068H	TS3 output step number	Set value
20/24/50/54H	03/06/10H	0069H	TS3 OFF time setting	Set value
20/24/50/54H	03/06/10H	006AH	TS3 ON time setting	Set value
		006BH to 007FH	Reserved (*1) to Reserved (*1)	
20/24/50/54H	03/06/10H	0080H	EV1 alarm setting	Set value (Decimal point ignored)
20/24/50/54H	03/06/10H	0081H	EV 1 high limit alarm setting	Set value (Decimal point ignored)
20/24/50/54H	03/06/10H	0082H	EV2 alarm setting	Set value (Decimal point ignored)
20/24/50/54H	03/06/10H	0083H	EV2 high limit alarm setting	Set value (Decimal point ignored)
20/24/50/54H	03/06/10H	0084H	EV3 alarm setting	Set value (Decimal point ignored)
20/24/50/54H	03/06/10H	0085H	EV3 high limit alarm setting	Set value (Decimal point ignored)
20/24/50/54H	03/06/10H	0086H	Heater burnout alarm setting 1	Set value (Decimal point ignored)
20/24/50/54H	03/06/10H	0087H	Heater burnout alarm setting 2	Set value (Decimal point ignored)
20/24/50/54H	03/06/10H	0088H	Loop break alarm time setting	Set value
20/24/50/54H	03/06/10H	0089H	Loop break alarm band setting	Set value (Decimal point ignored)
20/24/50/54H	03/06/10H	008AH	Loop break alarm dead band setting	Set value (Decimal point ignored)
		008BH to 008FH	Reserved (*1) to Reserved (*1)	
20/24/50/54H	03/06/10H	0090H	Fix control/program control selection	0000H : Fix control 0001H : Program control
20/24/50/54H	03/06/10H	0091H	Step time unit selection	0000H : Hours:Minutes 0001H : Minutes:Seconds
20/24/50/54H	03/06/10H	0092H	Power restore action selection	0 : Stops after power is restored. 1 : Continues (resumes) after power is restored. 2 : Suspends (on hold) after power is restored.
20/24/50/54H	03/06/10H	0093H	Program start temperature setting	Set value (Decimal point ignored)

Shinko Protocol Command Type	MODBUS Function Code	Data Item		Data
20/24/50/54H	03/06/10H	0094H	Program control start type selection	0 : PV start 1 : PVR start 2 : SV start
20/24/50/54H	03/06/10H	0095H	Number of repetitions setting	Set value
20/24/50/54H	03/06/10H	0096H	Reserved (*1)	
20/24/50/54H	03/06/10H	0097H	Reserved (*1)	
20/24/50/54H	03/06/10H	0098H	AT perform selection	0000H:AT cancel 0001H:AT perform
20/24/50/54H	03/06/10H	0099H	AT action model selection	0000H : Normal AT 0001H : Startup AT 0002H : FastAT
20/24/50/54H	03/06/10H	009AH	AT bias setting	Set value (Decimal point ignored)
20/24/50/54H	03/06/10H	009BH	AT gain setting	Set value (Decimal point ignored)
20/24/50/54H	03/06/10H	009CH	AT hysteresys setting	Set value (Decimal point ignored)
		009DH to 009FH	Reserved (*1) to Reserved (*1)	
20/24/50/54H	03/06/10H	00A0H	Event input EI1 allocation setting	0000H: No event 0001H: Set value memory 0002H: Control ON/OFF 0003H: Direct/Reverse action 0004H: Preset output 1 ON/OFF 0005H: Preset output 2 ON/OFF 0006H: Auto/Manual control 0007H: Remote/Local 0008H: Program control RUN/STOP 0009H: Program control Holding/Not holding 000AH: Program control Advance function 000BH: Integral action Holding 000CH: EV(x) output latch selection
20/24/50/54H	03/06/10H	00A1H	Event input EI2 allocation setting	Same as Event input EI1 allocation setting
20/24/50/54H	03/06/10H	00A2H	Event input EI3 allocation setting	Same as Event input EI1 allocation setting
20/24/50/54H	03/06/10H	00A3H	Event input EI4 allocation setting	Same as Event input EI1 allocation setting
		00A4H to 00A7H	Reserved (*1) to Reserved (*1)	
20/24/50/54H	03/06/10H	00A8H	Transmission output type selection	0000H : PV transmission 0001H : SV transmission 0002H : MV transmission
20/24/50/54H	03/06/10H	00A9H	Transmission output high limit setting	Set value (Decimal point ignored)
20/24/50/54H	03/06/10H	00AAH	Transmission output low limit setting	Set value (Decimal point ignored)
		00ABH	Reserved (*1)	
20/24/50/54H	03/06/10H	00ACH	Remote/Local selection	0000H : Local 0001H : Remote
20/24/50/54H	03/06/10H	00ADH	External setting input high limit setting	Set value (Decimal point ignored)
20/24/50/54H	03/06/10H	00AEH	External setting input low limit setting	Set value (Decimal point ignored)
20/24/50/54H	03/06/10H	00AFH	Remote bias setting	Set value (Decimal point ignored)

Shinko Protocol Command Type	MODBUS Function Code	Data Item		Data
20/24/50/54H	03/06/10H	00B0H	Control action selection	0000H : 2DOF PID control 0001H : Fast-PID control 0002H : Slow-PID control 0003H : Gap-PID control
20/24/50/54H	03/06/10H	00B1H	Proportional gain 2 DOF coefficient setting	Set value (Decimal point ignored)
20/24/50/54H	03/06/10H	00B2H	Integral 2 DOF coefficient setting	Set value (Decimal point ignored)
20/24/50/54H	03/06/10H	00B3H	Derivative 2 DOF coefficient setting	Set value (Decimal point ignored)
20/24/50/54H	03/06/10H	00B4H	Desired value proportional coefficient	Set value (Decimal point ignored)
20/24/50/54H	03/06/10H	00B5H	Gap width setting item	Set value (Decimal point ignored)
20/24/50/54H	03/06/10H	00B6H	Gap coefficient setting item	Set value (Decimal point ignored)
		00B7H	Reserved (*1)	
20/24/50/54H	03/06/10H	00B8H	Integral/Derivative decimal point position selection	0000H : No decimal point 0001H : With decimal point
		00B9H to 00BFH	Reserved (*1) to Reserved (*1)	
20/24/50/54H	03/06/10H	00C0H	Set value lock selection	0000H : Unlock 0001H : Lock 1 0002H : Lock 2
20/24/50/54H	03/06/10H	00C1H	SV Rise/Fall rate action selection	0 : SV start 1 : PV start
20/24/50/54H	03/06/10H	00C2H	SV Rise/Fall rate time unit selection	0 : Minutes 1 : Seconds
20/24/50/54H	03/06/10H	00C3H	SV rise rate setting	Set value (Decimal point ignored)
20/24/50/54H	03/06/10H	00C4H	SV fall rate setting	Set value (Decimal point ignored)
20/24/50/54H	03/06/10H	00C5H	LCD display part selection	0 : All LCD sections 1 : Lower section (including the operation indicator)
20/24/50/54H	03/06/10H	00C6H	SV display method selection (*3)	0000H : Set target value 0001H : Target value fluctuating during ramp function (Rise rate, fall rate, target values during program operation.)
20/24/50/54H	03/06/10H	00C7H	Indication when control output OFF selection	0000H : OFF indication 0001H : No indication 0002H : PV indication 0003H : PV indication + Any Alarm active
20/24/50/54H	03/06/10H	00C8H	OUT/OFF key function selection	0000H : No function 0001H : Auto/Manual control 0002H : Control output OFF function 0003H : Remote/Local selection 0004H : RUN/STOP function (enabled during program control)
20/24/50/54H	03/06/10H	00C9H	PF key function selection	0000H : No function 0001H : Auto/Manual control 0002H : Control output OFF function 0003H : Remote/Local selection 0004H : RUN/STOP function (enabled during program control)

Shinko Protocol Command Type	MODBUS Function Code	Data Item		Data
20/24/50/54H	03/06/10H	00CAH	Auto/Manual control after power ON selection	0 : Automatic control 1 : Manual control
20/24/50/54H	03/06/10H	00CBH	Indication time setting (*4)	Set value
20/24/50/54H	03/06/10H	00CCH	Non-volatile IC memory saving selection	0000H : Saving
20/24/50/54H	03/06/10H	00CDH	Response delay time setting	Set value
20/24/50/54H	03/06/10H	00CEH	SVTC bias setting	Set value
		00CFH	Reserved (*1)	
20/24/50/54H	03/06/10H	00D0H	Control output ON/OFF setting	0000H : OFF 0001H : ON
20/24/50/54H	03/06/10H	00D1H	Auto/Manual control	0000H : Automatic control 0001H : Manual control
20/24/50/54H	03/06/10H	00D2H	Manual control MV setting (*5)	Set value (Decimal point ignored)
20/24/50/54H	03/06/10H	00D3H	Program control RUN/STOP	0000H : STOP 0001H : RUN
20/24/50/54H	03/06/10H	00D4H	Program control ADVANCE (*6)	0000H : Usual control 0001H : ADVANCE
20/24/50/54H	03/06/10H	00D5H	Program control HOLD/Cancel	0000H : HOLD cancel 0001H : HOLD
20/24/50/54H	03/06/10H	00D6H	EV output by communication command setting	2 <sup>0</sup> : EV1 output 0 : OFF 1:ON 2 <sup>1</sup> : EV2 output 0 : OFF 1:ON 2 <sup>2</sup> : EV3 output 0 : OFF 1:ON 2 <sup>3 to 15</sup> : Undefined
		00D7H	Reserved (*1)	
20/24/50/54H	03/06/10H	00D8H	Date clear setting (*7) (*8)	0000H : Cancel 0001H : Execute
20/24/50/54H	03/06/10H	00D9H	Program clear setting (*8)	0000H : Cancel 0001H : Execute
20/24/50/54H	03/06/10H	00DAH to 00E9H	Reserved (*1) to Reserved (*1)	

### 7.1.2 Read Command

Shinko Protocol Command Type	MODBUS Function Code	Data Item		Data
20/24H	03H	03E8H	PV	Read value (Decimal point ignored)
20/24H	03H	03E9H	OUT1 MV	Read value (Decimal point ignored)
20/24H	03H	03EAH	OUT2 MV	Read value (Decimal point ignored)
20/24H	03H	03EBH	Current SV	Read value (Decimal point ignored)
20/24H	03H	03ECH	Status flag 1	2 <sup>0</sup> digit : OUT1 output 0 : OFF 1 : ON 2 <sup>1</sup> digit : OUT2 output 0 : OFF 1 : ON 2 <sup>2</sup> digit : EV1 output 0 : OFF 1 : ON 2 <sup>3</sup> digit : EV2 output 0 : OFF 1 : ON 2 <sup>4</sup> digit : EV3 output 0 : OFF 1 : ON 2 <sup>5</sup> to 2 <sup>9</sup> digit : Undefined (0) 2 <sup>10</sup> digit : Operating terminal short-circuit alarm 0 : OFF 1 : ON 2 <sup>11</sup> digit : Heater burnout alarm 0 : OFF 1 : ON 2 <sup>12</sup> digit : Loop break alarm 0 : OFF 1 : ON 2 <sup>13</sup> digit : Input high limit alarm 0 : OFF 1 : ON 2 <sup>14</sup> digit : Input low limit alarm 0 : OFF 1 : ON 2 <sup>15</sup> digit : Change in key operation (*9) 0 : No 1 : Yes
20/24H	03H	03EDH	Status flag 2	2 <sup>0</sup> : Warm-up 0: Finished 1: Warm-up 2 <sup>1</sup> : EI input 0 : OFF 1:ON 2 <sup>2</sup> : E2 input 0 : OFF 1:ON 2 <sup>3</sup> : E3 input 0 : OFF 1:ON 2 <sup>4</sup> : E4 input 0 : OFF 1:ON 2 <sup>5</sup> : Power supply 0: Instrument power 1: USB power 2 <sup>6</sup> : Undefined (Always 0) 2 <sup>7</sup> : Control status 0: Prohibited 1: Permitted 2 <sup>8</sup> : AT status 0: Stop 1: During AT 2 <sup>9</sup> : Auto/Manual control 0: Automatic control 1: Manual control 2 <sup>10</sup> : Remote/Local 0: Local 1: Remote 2 <sup>11</sup> : Control mode 0: Fixed value control 1: Program control 2 <sup>12</sup> : Program control 0: Stop 1: Run 2 <sup>13</sup> : Wait function 0: OFF 1: ON 2 <sup>14</sup> : Hold function 0: OFF 1: ON 2 <sup>15</sup> : Pattern end function 0: OFF 1: ON
20/24H	03H	03EEH	CT1 current value	Read value (Decimal point ignored)
20/24H	03H	03EFH	CT2 current value	Read value (Decimal point ignored)
20/24H	03H	03F0H	Ambient temperature	Read value (Decimal point ignored)
20/24H	03H	03F1H	Setting value memory number	Read value (Decimal point ignored)
20/24H	03H	03F2H	Program control operation step number	Read value (Decimal point ignored)
20/24H	03H	03F3H	Program control operation remaining time	Read value (Decimal point ignored)
20/24H	03H	03F4H	Program control operation number of repetitions	Read value (Decimal point ignored)
20/24H	03H	03F5H	Error status flag	2 <sup>0</sup> : Alarm 1 2 <sup>1</sup> : Alarm 2

Shinko Protocol Command Type	MODBUS Function Code	Data Item		Data
				2 <sup>2</sup> : Alarm 3 2 <sup>3</sup> : Undefined (Always 0) 2 <sup>4</sup> : Heater burnout alarm 2 <sup>5</sup> : Operation terminal short-circuit alarm 2 <sup>6</sup> : Loop break alarm 2 <sup>7</sup> : Sensor error 2 <sup>8</sup> : Overscale 2 <sup>9</sup> : Underscale 2 <sup>10</sup> : Cold junction error 2 <sup>11</sup> : Non-volatile IC memory error 0: Normal  1: Error 2 <sup>12</sup> : Hardware error 2 <sup>13</sup> : Undefined (Always 0) 2 <sup>14</sup> : Undefined (Always 0) 2 <sup>15</sup> : Undefined (Always 0)
20/24H	03H	03F6H	Reserved (*1)	
			to	
20/24H	03H	03FBH	Reserved (*1)	
20/24H	03H	03FCH	EVT input display	Read value (Decimal point ignored)
20/24H	03H	03FDH	Key operation change item reading (*9)	Read value (Decimal point ignored)

### 7.1.3 Program Control Command

Shinko Protocol Command Type	MODBUS Function Code	Data Item		Data		
20/24/50/54H	03/06/10H	1000H	Step 1 SV setting	Set value		
		1001H	Step 1 time setting	Set value		
		1002H	Step 1 wait block No. setting	Set value		
		1003H	Step 1 PID block No. setting	Set value		
		1004H	Step 2 SV setting	Set value		
		1005H	Step 2 time setting	Set value		
		1006H	Step 2 wait block No. setting	Set value		
		1007H	Step 2 PID block No. setting	Set value		
		1008H	Step 3 SV setting	Set value		
		1009H	Step 3 time setting	Set value		
		100AH	Step 3 wait block No. setting	Set value		
		100BH	Step 3 PID block No. setting	Set value		
		100CH	Step 4 SV setting	Set value		
		100DH	Step 4 time setting	Set value		
		100EH	Step 4 wait block No. setting	Set value		
		100FH	Step 4 PID block No. setting	Set value		
		1010H	Step 5 SV setting	Set value		
		1011H	Step 5 time setting	Set value		
		1012H	Step 5 wait block No. setting	Set value		
		1013H	Step 5 PID block No. setting	Set value		
		1014H	Step 6 SV setting	Set value		
		1015H	Step 6 time setting	Set value		
		1016H	Step 6 wait block No. setting	Set value		
		1017H	Step 6 PID block No. setting	Set value		
		1018H	Step 7 SV setting	Set value		
				1019H	Step 7 time setting	Set value
				101AH	Step 7 wait block No. setting	Set value
				101BH	Step 7 PID block No. setting	Set value
				101CH	Step 8 SV setting	Set value
				101DH	Step 8 time setting	Set value
				101EH	Step 8 wait block No. setting	Set value
				101FH	Step 8 PID block No. setting	Set value
				1020H	Step 9 SV setting	Set value
				1021H	Step 9 time setting	Set value
				1022H	Step 9 wait block No. setting	Set value
1023H	Step 9 PID block No. setting			Set value		
1024H	Step 10 SV setting			Set value		
1025H	Step 10 time setting			Set value		
1026H	Step 10 wait block No. setting			Set value		
1027H	Step 10 PID block No. setting			Set value		
1028H	Step 11 SV setting			Set value		
1029H	Step 11 time setting			Set value		
102AH	Step 11 wait block No. setting			Set value		
102BH	Step 11 PID block No. setting			Set value		
102CH	Step 12 SV setting			Set value		
102DH	Step 12 time setting			Set value		
102EH	Step 12 wait block No. setting			Set value		
102FH	Step 12 PID block No. setting			Set value		
1030H	Step 13 SV setting			Set value		
1031H	Step 13 time setting			Set value		
1032H	Step 13 wait block No. setting			Set value		
1033H	Step 13 PID block No. setting			Set value		
1034H	Step 14 SV setting			Set value		
1035H	Step 14 time setting			Set value		

Shinko Protocol Command Type	MODBUS Function Code	Data Item		Data
		1036H	Step 14 wait block No. setting	Set value
		1037H	Step 14 PID block No. setting	Set value
		1038H	Step 15 SV setting	Set value
		1039H	Step 15 time setting	Set value
		103AH	Step 15 wait block No. setting	Set value
		103BH	Step 15 PID block No. setting	Set value
		103CH	Step 16 SV setting	Set value
		103DH	Step 16 time setting	Set value
		103EH	Step 16 wait block No. setting	Set value
		103FH	Step 16 PID block No. setting	Set value

### 7.1.4 Wait Block Setting Command

Shinko Protocol Command Type	MODBUS Function Code	Data Item		Data
20/24/50/54H	03/06/10H	1100H	Wait block No.1 wait setting	Set value (Decimal point ignored)
		1101H	Wait block No.2 wait setting	Set value (Decimal point ignored)
		1102H	Wait block No.3 wait setting	Set value (Decimal point ignored)
		1103H	Wait block No.4 wait setting	Set value (Decimal point ignored)
		1104H	Wait block No.5 wait setting	Set value (Decimal point ignored)
		1105H	Wait block No.6 wait setting	Set value (Decimal point ignored)
		1106H	Wait block No.7 wait setting	Set value (Decimal point ignored)
		1107H	Wait block No.8 wait setting	Set value (Decimal point ignored)

### 7.1.5 PID Block Setting Command

Shinko Protocol Command Type	MODBUS Function Code	Data Item		Data
20/24/50/54H	03/06/10H	1120H	Block1 OUT1 proportional band setting	Set value (Decimal point ignored)
		1121H	Block1 OUT1 integral time setting	Set value (Decimal point ignored)
		1122H	Block1 OUT1 derivative time setting	Set value (Decimal point ignored)
		1123H	Block1 OUT2 proportional band setting	Set value (Decimal point ignored)
		1124H	Block1 OUT2 integral time setting	Set value (Decimal point ignored)
		1125H	Block1 OUT2 derivative time setting	Set value (Decimal point ignored)
		1126H	Block1 MV bias setting	Set value (Decimal point ignored)
		1127H	Block1 overlap, deadband setting	Set value (Decimal point ignored)
		1128H	Block2 OUT1 proportional band setting	Set value (Decimal point ignored)
		1129H	Block2 OUT1 integral time setting	Set value (Decimal point ignored)
		112AH	Block2 OUT1 derivative time setting	Set value (Decimal point ignored)
		112BH	Block2 OUT2 proportional band setting	Set value (Decimal point ignored)
		112CH	Block2 OUT2 integral time setting	Set value (Decimal point ignored)
		112DH	Block2 OUT2 derivative time setting	Set value (Decimal point ignored)
		112EH	Block2 MV bias setting	Set value (Decimal point ignored)
		112FH	Block2 overlap, deadband setting	Set value (Decimal point ignored)
		1130H	Block3 OUT1 proportional band setting	Set value (Decimal point ignored)
		1131H	Block3 OUT1 integral time setting	Set value (Decimal point ignored)
		1132H	Block3 OUT1 derivative time setting	Set value (Decimal point ignored)
		1133H	Block3 OUT2 proportional band setting	Set value (Decimal point ignored)
1134H	Block3 OUT2 integral time setting	Set value (Decimal point ignored)		
1135H	Block3 OUT2 derivative time setting	Set value (Decimal point ignored)		
1136H	Block3 MV bias setting	Set value (Decimal point ignored)		
1137H	Block3 overlap, deadband setting	Set value (Decimal point ignored)		
1138H	Block4 OUT1 proportional band setting	Set value (Decimal point ignored)		

Shinko Protocol Command Type	MODBUS Function Code	Data Item	Data	
		1139H	Block4 OUT1 integral time setting	Set value (Decimal point ignored)
		113AH	Block4 OUT1 derivative time setting	Set value (Decimal point ignored)
		113BH	Block4 OUT2 proportional band setting	Set value (Decimal point ignored)
		113CH	Block4 OUT2 integral time setting	Set value (Decimal point ignored)
		113DH	Block4 OUT2 derivative time setting	Set value (Decimal point ignored)
		113EH	Block4 MV bias setting	Set value (Decimal point ignored)
		113FH	Block4 overlap, deadband setting	Set value (Decimal point ignored)
		1140H	Block5 OUT1 proportional band setting	Set value (Decimal point ignored)
		1141H	Block5 OUT1 integral time setting	Set value (Decimal point ignored)
		1142H	Block5 OUT1 derivative time setting	Set value (Decimal point ignored)
		1143H	Block5 OUT2 proportional band setting	Set value (Decimal point ignored)
		1144H	Block5 OUT2 integral time setting	Set value (Decimal point ignored)
		1145H	Block5 OUT2 derivative time setting	Set value (Decimal point ignored)
		1146H	Block5 MV bias setting	Set value (Decimal point ignored)
		1147H	Block5 overlap, deadband setting	Set value (Decimal point ignored)
		1148H	Block6 OUT1 proportional band setting	Set value (Decimal point ignored)
		1149H	Block6 OUT1 integral time setting	Set value (Decimal point ignored)
		114AH	Block6 OUT1 derivative time setting	Set value (Decimal point ignored)
		114BH	Block6 OUT2 proportional band setting	Set value (Decimal point ignored)
		114CH	Block6 OUT2 integral time setting	Set value (Decimal point ignored)
		114DH	Block6 OUT2 derivative time setting	Set value (Decimal point ignored)
		114EH	Block6 MV bias setting	Set value (Decimal point ignored)
		114FH	Block6 overlap, deadband setting	Set value (Decimal point ignored)
		1150H	Block7 OUT1 proportional band setting	Set value (Decimal point ignored)
		1151H	Block7 OUT1 integral time setting	Set value (Decimal point ignored)
		1152H	Block7 OUT1 derivative time setting	Set value (Decimal point ignored)

Shinko Protocol Command Type	MODBUS Function Code	Data Item	Data	
		1153H	Block7 OUT2 proportional band setting	Set value (Decimal point ignored)
		1154H	Block7 OUT2 integral time setting	Set value (Decimal point ignored)
		1155H	Block7 OUT2 derivative time setting	Set value (Decimal point ignored)
		1156H	Block7 MV bias setting	Set value (Decimal point ignored)
		1157H	Block7 overlap, deadband setting	Set value (Decimal point ignored)
		1158H	Block8 OUT1 proportional band setting	Set value (Decimal point ignored)
		1159H	Block8 OUT1 integral time setting	Set value (Decimal point ignored)
		115AH	Block8 OUT1 derivative time setting	Set value (Decimal point ignored)
		115BH	Block8 OUT2 proportional band setting	Set value (Decimal point ignored)
		115CH	Block8 OUT2 integral time setting	Set value (Decimal point ignored)
		115DH	Block8 OUT2 derivative time setting	Set value (Decimal point ignored)
		115EH	Block8 MV bias setting	Set value (Decimal point ignored)
		115FH	Block8 overlap, deadband setting	Set value (Decimal point ignored)

- (\*1): For Reserved items, performing a read/block read operation returns an acknowledgment, and the data returns the default value (0).  
For configuration/block configuration operations, the configuration data is discarded and an acknowledgment is returned.
- (\*2): When changing operation via Event output EV1, Event output EV2, or Event output EV3 output allocation selection, the EV1 and EV2 alarm setting values will be initialized.
- (\*3): The ramp function for the SV display method selection corresponds to the target value during fluctuation (0001H), which represents the target value when setting the SV rise/fall rate and the target value during program operation.
- (\*4): The Indication time setting value is set within the range of 0 to 3600 seconds (0 to 0E10H) for the setting range of 00:00 to 60:00 (minutes:seconds).
- (\*5): When the control action is ON/OFF, setting a value other than the OUT1 low limit setting value or the OUT1 high limit setting value will return error code 3 (33H). For MODBUS, it will return exception code 3 (03H).  
When the cooling control action is set to ON/OFF mode in heating/cooling control, setting values outside the range of OUT1 low limit setting value to OUT1 high limit setting value for heating, or OUT2 low limit setting value to OUT2 high limit setting value for cooling, will return error code 3 (33H) or, in MODBUS, exception code 3 (03H).  
When using heating/cooling control with ON/OFF action, setting values other than the OUT1 low limit setting value and OUT1 high limit setting value for the heating side, or the OUT2 low limit setting value and OUT2 high limit setting value for the cooling side, will return error code 3 (33H) or, for MODBUS, exception code 3 (03H).
- (\*6): Program control advance execution (00D4H) returns error code 1 (31H) when read, and in MODBUS, it returns exception code 2 (02H).

For setting data, sending setting data other than setting data (0001H) will return error code 3 (33H). For MODBUS, it will return exception code 3 (03H).

- (\*7): Executing the data clear execute/cancel selection (00D8H) will restore the device to its factory default settings. Therefore, if communication was established using settings different from the factory defaults, communication will become impossible.
- (\*8): This item returns error code 1 (31H) when read, or MODBUS exception code 2 (02H).  
When setting, sending setting data other than setting data (0001H) returns error code 3 (33H), or MODBUS exception code 3 (03H).
- (\*9): When key operation is performed, the key operation change bit in status flag 1 is set. The operated item can be read via the key operation change item read operation, and reading the operated item clears the key operation change bit.

## 7.2 Data

### 7.2.1 Notes about Write/Read Command

- The data (set value, decimal) is converted to a hexadecimal number. Negative numbers are represented in 2's complement.
- When connecting multiple slaves, the address (instrument number) must not be duplicated.
- Do not use undefined Data items. If they are used, negative acknowledgement will be returned or a random value will be written or read, resulting in malfunction.
- MODBUS protocol uses Holding Register addresses. The Holding Register addresses are created as follows. A Shinko command data item is converted to decimal number, and the offset of 40001 is added. The result is the Holding Register address.  
Using Data item 0001H (SV1) as an example: Data item in the sending message is 0001H, however, MODBUS protocol Holding Register address is 40002 (1 + 40001).

### 7.2.2 Write Command

- Up to about 1 trillion entries can be stored in non-volatile IC memory.  
If the number of settings exceeds the limit, the data will not be saved. So, do not change the set values frequently via software communication. (If a value set via software communication is the same as the value before the setting, the value will not be written in non-volatile IC memory.)
- Setting range of each item is the same as that of keypad operation.
- When data (set value) has a decimal point, a whole number (hexadecimal) without a decimal point is used.
- If any action is changed at 0050H (Event output EV1 allocation), at 0059H (Event output EV2 allocation) or at 0062H (Event output EV3 allocation), the following values will revert to the factory default value: EV1 alarm value (0012H), EV2 alarm value (0014H), EV3 alarm value (0084H), etc.  
For the items to be initialized, refer to Section "7.6 Items to Be Initialized by Changing Settings" (p.40).
- Writings via software communication are possible while in Set value lock status.
- Even if options are not ordered, writing or reading via software communication will be possible. However, their command contents will not function.
- Communication parameters such as Instrument Number, Communication Speed of the slave cannot be set by software communication. They can only be set via the keypad. See pages 4, 5.
- When Write is executed using the Global address [95 (7FH), Shinko protocol] command or Broadcast address [(00H) MODBUS protocol] command, the command is sent to all the connected slaves. However, a response is not returned.

### 7.2.3 Read Command

- When the data (set value) has a decimal point, a whole number (hexadecimal) without a decimal point is used for a response.

## 7.3 Negative Acknowledgement

### 7.3.1 Error code 1 (31H) (Shinko protocol) or Exception code 2 (02H) (MODBUS protocol)

The slave will return Error code 1 (31H) (Shinko protocol) or Exception code 2 (02H) (MODBUS protocol) in the following case.

- When non-existent data item is read or written.

### 7.3.2 Error code 3 (33H) (Shinko protocol) or Exception code 3 (03H) (MODBUS protocol)

The slave will return Error code 3 (33H) (Shinko protocol) or Exception code 3 (03H) (MODBUS protocol) in the following case.

- When a value out of the setting range is written.

### 7.3.3 Error code 4 (34H) (Shinko protocol) or Exception code 17 (11H) (MODBUS protocol)

The slave will return Error code 4 (34H) (Shinko protocol) or Exception code 17 (11H) (MODBUS protocol) in the following cases.

- When 0001H (AT perform) is written at 0098H (AT perform selection) during PI control or ON/OFF control action.
- While AT is performing during Fixed value control, if 0001H (AT perform) is written at 0098H (AT perform selection).  
While AT is performing in Fixed value control, and if 00C8H (OUT/OFF key function) is written.
- While AT is performing during Program control, if 0001H (AT/Auto-reset Perform) is written at 0001H (AT/Auto-reset Perform/Cancel).  
While AT is performing during Program control, and if 00C8H (OUT/OFF key function) is written.
- When 0002H (Manual control MV) is written during automatic control

### 7.3.4 Error code 5 (35H) (Shinko protocol) or Exception code 18 (12H) (MODBUS protocol)

The slave will return Error code 5 (35H) (Shinko protocol) or Exception code 18 (12H) (MODBUS protocol) in the following case.

- During setting mode by keypad operation

## 7.4 Notes on Programming Monitoring Software

### 7.4.1 How to Speed up the Scan Time

When monitoring multiple units of the controller, set the program so that the requisite minimum pieces of data such as Data item 03E8H (PV), Data item 03E9H (OUT1 MV), Data item 03ECH (Status flag 1), can be read.

For other data, set the program so that they can be read only when their set value has changed.

This will speed up the scan time.

### 7.4.2 How to Read the Set Value Changes Made by Front Keypad Operation

If any set value is changed by the keypad operation, the controller sets the [03ECH (Status flag 1) B15: Change in key operation] to 1 (Yes).

When the key operation is executed, the key operation change bit in Status flag 1 is set. The operated item can be read using the key operation change item read function. Reading the operated item clears the key operation change bit.

### 7.4.3 How to Read PID Parameters after Normal AT, 'AT on Startup' or Fast AT

This instrument sets "Running (1)" in the B8: AT state field of Status flag 2 (03EDH) during Normal AT, 'AT on Startup', or Fast AT.

After completing Normal AT, 'AT on Startup', or Fast AT, update the PID parameters.

When the monitor software detects that the AT status (B8) in Status flag 2 (03EDH) is set to "Stop (0)", read the P, I, and D values.

### 7.4.4 Note When Sending All Set Values Simultaneously

- When changing alarm types at 0050H (Event output EV1 allocation), at 0059H (Event output EV2 allocation) or at 0062H (Event output EV3 allocation), the following values will revert to 0 (zero).

EV1 alarm value (0080H), EV2 alarm value (0082H) , EV3 alarm value (0084H)

First, send the selected alarm type, then send each alarm value.

Refer to Section '7.6 Items to be Initialized by Changing Settings'. (p.40)

- When changing input types 0002H (Input type) or temperature unit 0021H (Temperature unit selection), values such as SV1, OUT1 proportional band, EV1 Alarm value, etc. will be initialized.

First, send the selected input type, then send other set values.

## 7.5 Items to Be Initialized by Changing Settings

If settings are changed, the following items will be initialized.

- : Initialized
- : Not initialized

Setting item to be changed Item to be initialized	Input type (0020H)	Event output EV1 allocation (0050H)	Event output EV2 allocation (0059H)	Event output EV3 allocation (0062H)	Transmission output (00A8H)
SV1 to SV8 setting (1000 to 103CH)	○	—	—		—
Steps 1 to 16 SV setting (1000 to 103CH)	○	—	—	—	—
Steps 1 to 16 time setting (1001 to 103DH)	○	—	—	—	—
Steps 1 to 16 wait block number setting (1002 to 103EH)	○	—	—		—
Steps 1 to 16 PID block number setting (1003 to 103FH)	○	—	—	—	—
AT bias setting (009AH)	○	—	—		—
AT hysteresys setting (009CH)	○	—	—	—	—
Block 1 to 8 OUT1 proportional band setting (1120 to 1158H)	○	—	—		—
Block 1 to 8 OUT1 integral time setting (1121 to 1159H)	○	—	—	—	—
Block 1 to 8 OUT1 derivative time setting (1122 to 115AH)	○	—	—	—	—
Block 1 to 8 OUT2 proportional band setting (1123 to 115BH)	○	—	—	—	—
Block 1 to 8 OUT2 integral time setting (1124 to 115CH)	○	—	—	—	—
Block 1 to 8 OUT2 derivative time setting (1125 to 115DH)	○	—	—	—	—
Block 1 to 8 MV bias setting (1126 to 115EH)	○	—	—	—	—
Block 1 to 8 Overlap/deadband setting (1127 to 115FH)	○	—	—	—	—
EV1 alarm setting (0080H)	○	○	—	—	—
EV1 high limit alarm setting (0081H)	○	○	—	—	—
EV2 alarm setting (0082H)	○	—	○	—	—
EV2 high limit alarm setting (0083H)	○	—	○	—	—
EV3 alarm setting (0084H)	○	—	—	○	—
EV3 high limit alarm setting	○	—	—	○	—

Setting item to be changed Item to be initialized	Input type (0020H)	Event output EV1 allocation (0050H)	Event output EV2 allocation (0059H)	Event output EV3 allocation (0062H)	Transmission output (00A8H)
(0085H)					
Loop break alarm time setting (0088H)	○	—	—	—	—
Loop break alarm dead band setting (0089H)	○	—	—	—	—
Loop break alarm deadband setting (008AH)	○	—	—	—	—
Scaling high limit setting (0022H)	○	—	—	—	—
Scaling low limit setting (0023H)	○	—	—	—	—
Sensor correction coefficient setting (0027H)	○	—	—	—	—
Sensor correction setting (0028H)	○	—	—	—	—
OUT1 ON/OFF hysteresis setting (0032H)	○	—	—	—	—
OUT2 ON/OFF hysteresis setting (0039H)	○	—	—	—	—
EV1 hysteresis setting (0052H)	○	—	—	—	—
EV2 hysteresis setting (005BH)	○	—	—	—	—
EV3 hysteresis setting (0064H)	○	—	—	—	—
SVTC bias setting (00CEH)	○	—	—	—	—
Transmission output high limit setting (Except MV transmission) (00A9H)	○	—	—	—	○
Transmission output low limit setting (Except MV transmission) (00AAH)	○	—	—	—	○
External setting input high limit setting (00ADH)	○	—	—	—	—
External setting input low limit setting (00AEH)	○	—	—	—	—
Remote bias setting (00AFH)	○	—	—	—	—
Program start temperature setting (0093H)	○	—	—	—	—
Block 1 to 8 wait setting (1100 to 1107H)	○	—	—	—	—
SV rise rate setting (00C3H)	○	—	—	—	—
SV fall rate setting (00C4H)	○	—	—	—	—

## 8. PLC Link Function

The PLC Link function establishes a serial connection with Mitsubishi Electric Corporation's PLC Q Series and uses the PLC's communication protocol to read and write various data to PLC registers.

It supports the following communication protocols and communication commands.

Communication Protocol	Format 4
Communication Command	A-compatible 1C Frame AnA/AnU Common Command (QR/QW)

For the console software (SWC-ACS201M), configure specifications by selecting the starting number for PLC registers, as well as the monitor items and setting items linked to the PLC register addresses.

Program-free communication operation

Configuration example of PLC and ACS2

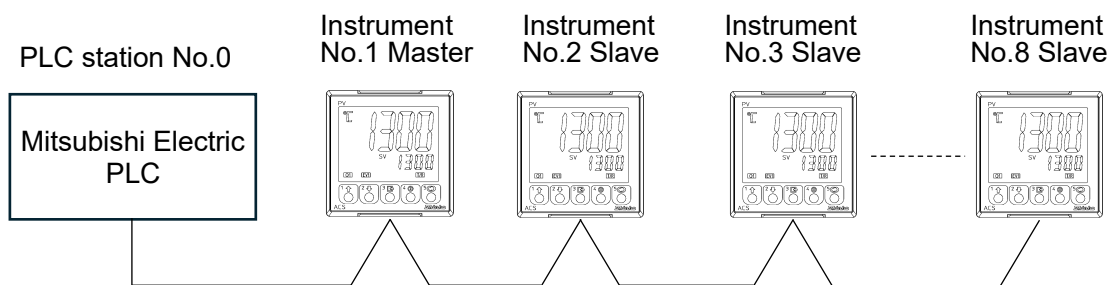

Maximum of 8 units on the one communication line

Program-free communication designates the device with ACS2 instrument number 1 as the master.

The instrument number 1 master communicates with the instrument number 2 slave, instrument number 3 slave, and so on up to the instrument number maximum setting value slave in sequence to acquire data for the selected monitor items. Upon acquiring data, the instrument number 1 master uses the QW command to write to the PLC register, updating the PLC register value.

Master (Instrument No.1)→Slave (Instrument No.2)→……→Slave (Maximum Instrument No. setting value)

Master (Instrument No.1)→PLC (Station No.0)

Instrument No. 1 Master reads the selected setting items from the PLC registers via a setting request using a QR command. If the read data has been modified, it updates the ACS2 setting value.

PLC (Station No.0)→Master (Instrument No.1)→Slave (Requested Instrument No.)

## 8.1 Operation Flow

The steps to start operation when connecting and using the PLC and ACS2 are shown below.

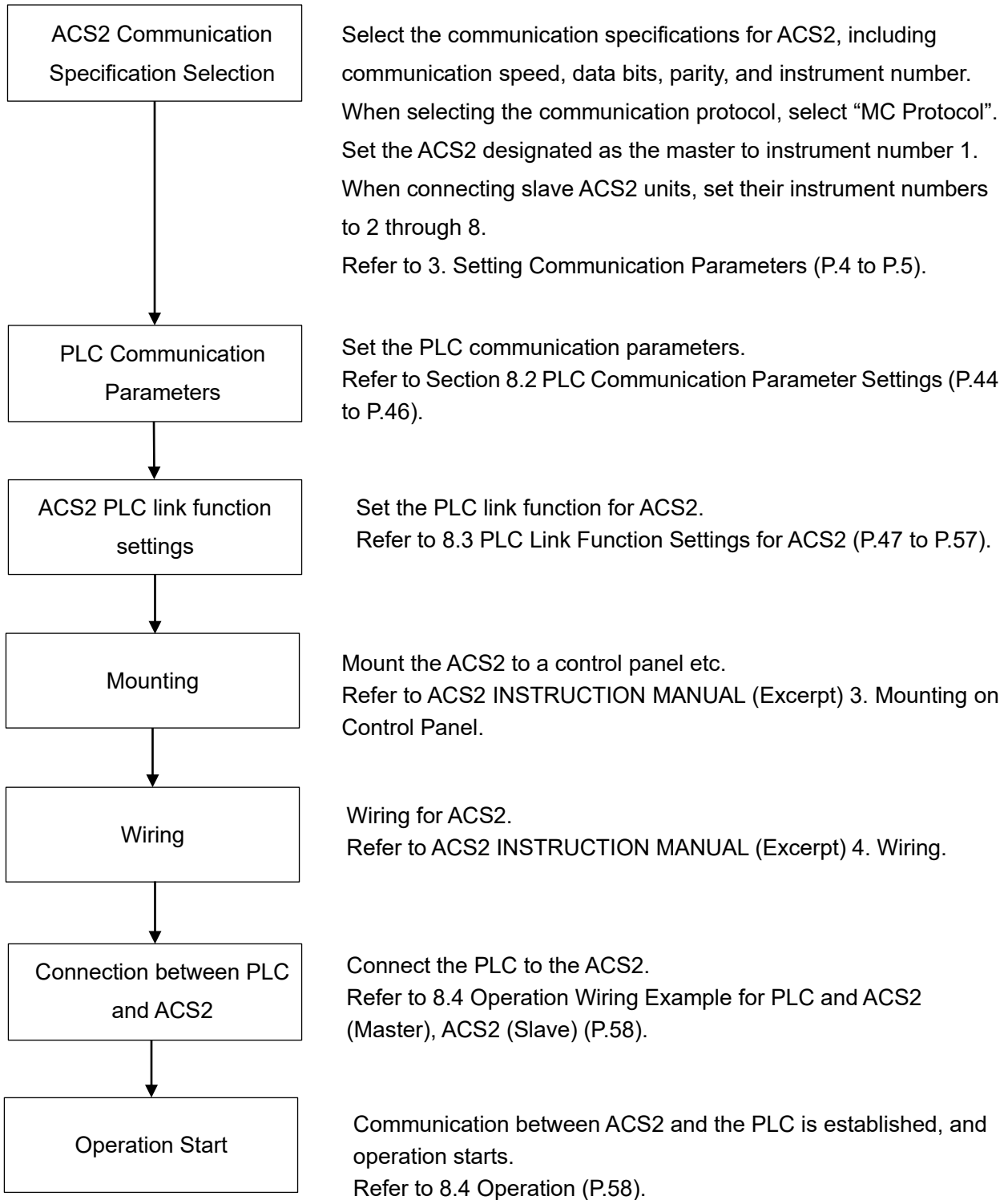

(Fig. 8.1-1)

## 8.2 PLC Communication Parameter Settings

Sets the PLC communication parameters.

This section explains the setting method using GX Works3.

Connect the computer with GX Works3 installed, set the communication speed, transmission specifications, and communication protocol, then set the communication parameters using the PC write function.

For details, refer to the Serial Communication Unit User's Manual (Basic Edition).

### (1) I/O Allocation Settings

Double click the Project Data List - Parameter - PC parameter.

The Parameter Settings screen will appear.

Click the I/O Assignment tab and set "Type", "Model Name" and "Points".

Q Parameter Setting

PLC Name | PLC System | PLC File | PLC RAS | Program | SFC | Device | **I/O Assignment** | Multiple CPU Setting | Serial Communication

I/O Assignment(\*1)

No.	Slot	Type	Model Name	Points	Start XY
0	PLC	PLC			
1	0(0-0)	Intelligent	QJ71C24N	32Points	
2	1(0-1)				
3	2(0-2)				
4	3(0-3)				
5	4(0-4)				
6	5(0-5)				
7	6(0-6)				

Assigning the I/O address is not necessary as the CPU does it automatically.  
Leaving this setting blank will not cause an error to occur.

Base Setting(\*1)

	Base Model Name	Power Model Name	Extension Cable	Slots
Main				8
Ext.Base1				
Ext.Base2				
Ext.Base3				
Ext.Base4				

Base Mode  
 Auto  
 Detail  
 8 Slot Default  
 12 Slot Default  
 Select module name

Export to CSV File | Import Multiple CPU Parameter | Read PLC Data

(\*1)Setting should be set as same when using multiple CPU.

Print Window... | Print Window Preview | Acknowledge XY Assignment | Default | Check | End | Cancel

(Fig. 8.2-1)

[Setting Example]

Setting Item	Settings
Type	Intelligent
Model Name	Unit model name to be installed (e.g., QJ71C24N)
Number of Points	32 points

(2) Switch Settings

Click the [Switch Setting] button to the right of the I/O Assignment.

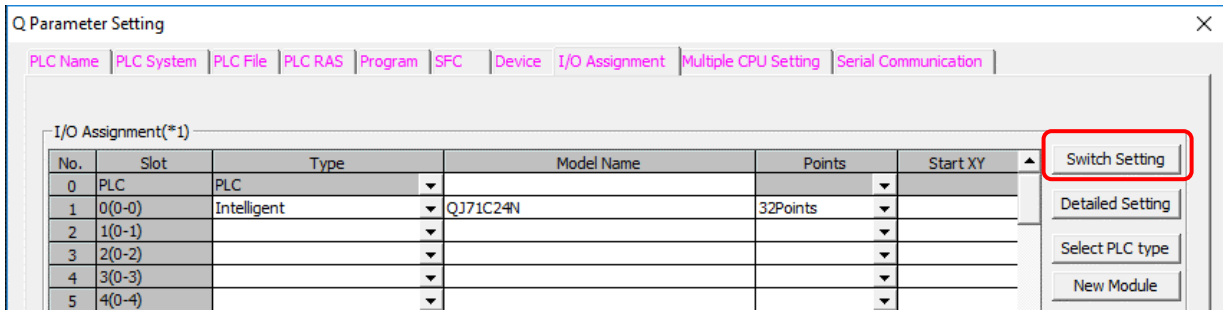

(Fig. 8.2-2)

Display the I/O unit and intelligent function unit switch settings screen.

Set the data bits, parity bits, stop bits, communication speed, and communication protocol settings.

[Setting Example]

Setting Item	Settings
Operation Settings	Independent
Data bits	8 bits
Parity bits	Even
Stop bits	1 bit
Samcheck code	Available
Writing during RUN	Permitted
Setting Changes	Prohibited
Communication speed settings	Set the same communication speed as ACS2 ( setting example: 57600 bps)
Communication protocol settings	Format 4

After setting, click the [ End ] button.

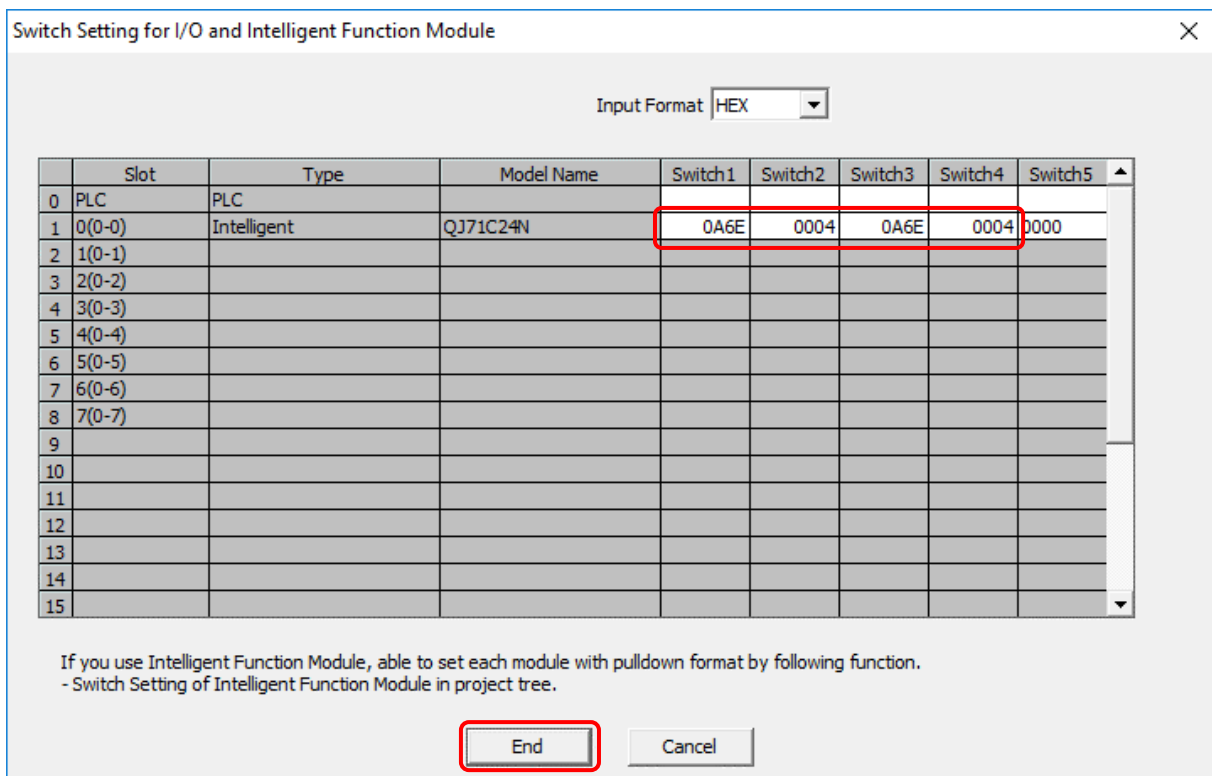

(Fig. 8.2-3)

### (3) PC Writing

Click Menu Bar - Online - Write to PLC.

The PC Write screen will appear.

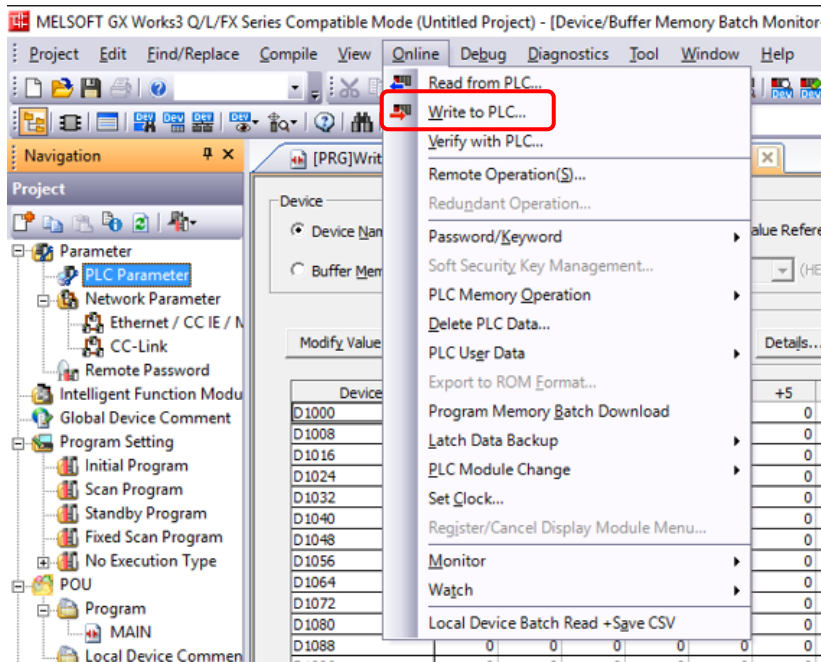

(Fig. 8.2-4)

Click the [Select All] button - [Execute] button.

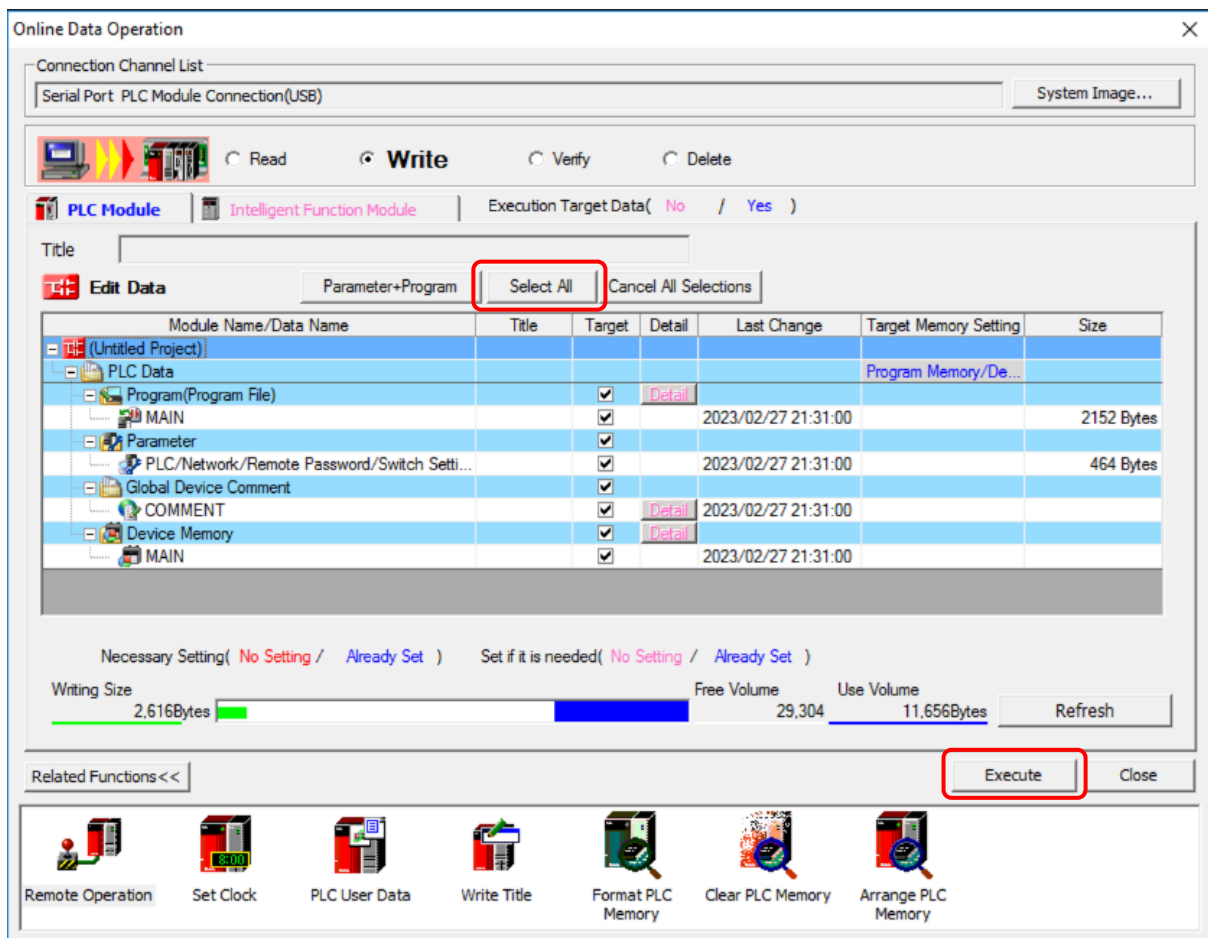

(Fig. 8.2-5)

The PLC communication parameter settings are now complete.

### 8.3 PLC Link Function Settings for ACS2

To communicate with the PLC, set the specifications for the ACS2.

This section explains how to set specifications using the console software (SWC-ACS201M).

Tool cable and console software preparation

Please prepare the tool cable and console software.

- Tool cable

CMD-001

- Console software (SWC-ACS201M)

Please download and install it from our website.

<https://shinko-technos.co.jp/> → Support/Download → Downloads → Click Software

Connection to the host computer

## Caution

When connecting a tool cable for communication, do not use the logging function of the console software.

- (1) Connect the tool cable CMD-001 to the console connector on this instrument.
- (2) Connect the USB plug of the USB cable to the USB port on the host computer.

Example of Host Computer and ACS2 Connection

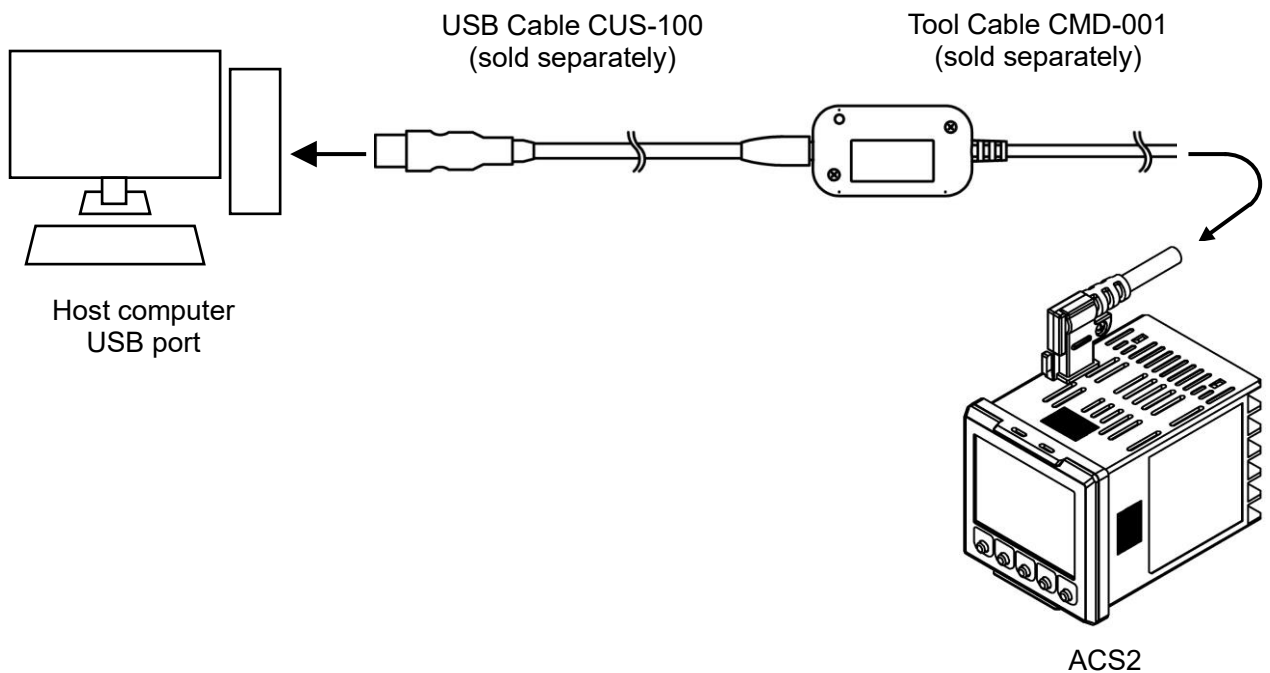

(Fig. 8.3-1)

### (3) Checking the COM Port Number

Follow the steps below to check the COM port number.

- ① Right-click the “Start” button - Click “Device Manager”.
- ② If “USB Serial Port (COM3)” is displayed under “Ports (COM and LPT)”, the COM port has been allocated as port number 3.

After checking the COM port number, close “Device Manager”.



(Fig. 8.3-2)

- (4) Launch the Console Software (SWC-ACS201M)
- ① Launch the console software (SWC-ACS201M).



(Fig. 8.3-3)

- ② Click User (U) - Communication Conditions (C) in the menu bar.  
The Communication Conditions Settings screen will appear.

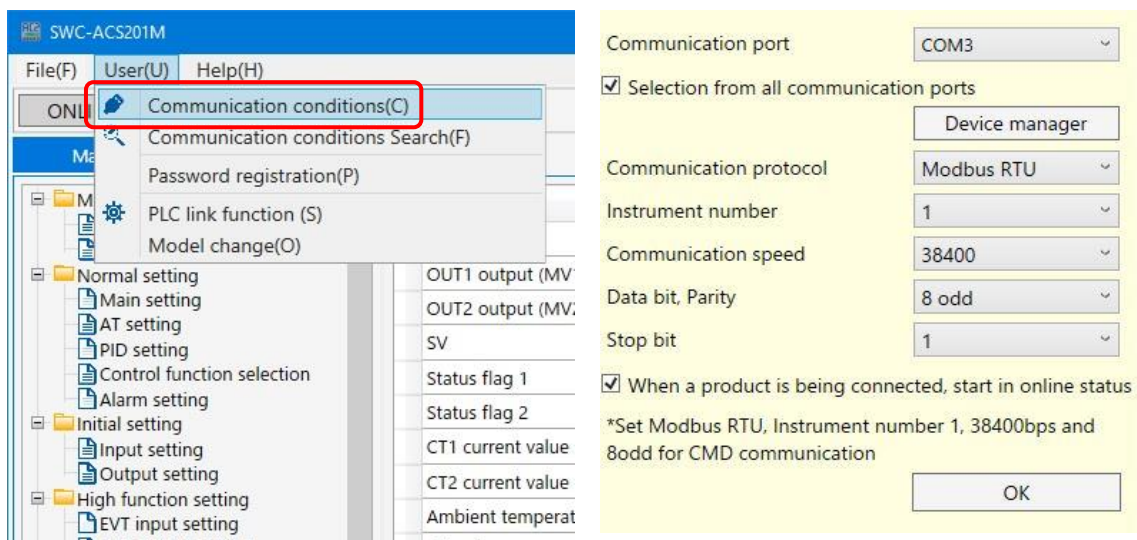

(Fig. 8.3-4)

- ③ Set the communication conditions as follows.

Setting Item	Settings
Communication port	Select the COM port number confirmed in (3)-②.
Communication protocol	MODBUS RTU

- ④ Click the OK button.

- ⑤ Click User (U) – PLC Link Function (S) in the menu bar.

The PLC Link Function Initial Settings screen will appear.

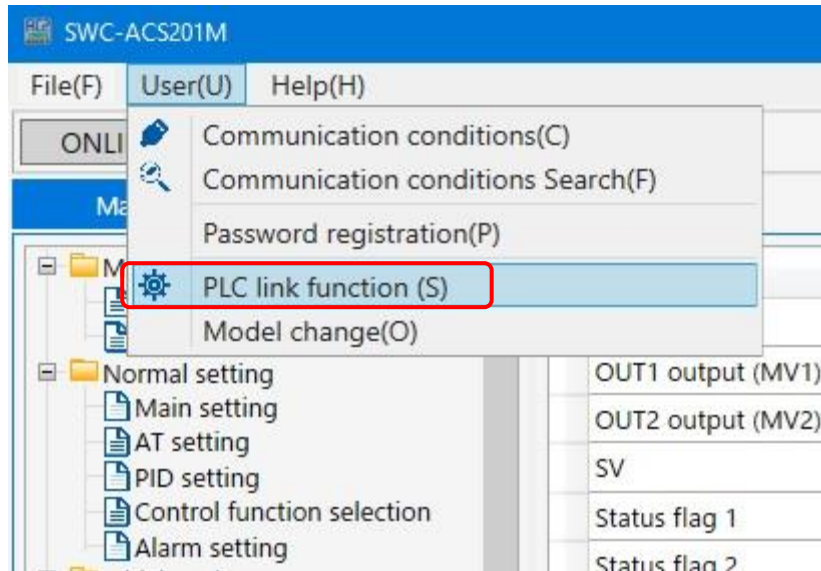

(Fig. 8.3-5)

- ⑥ Select Module 1 and click the System tab.

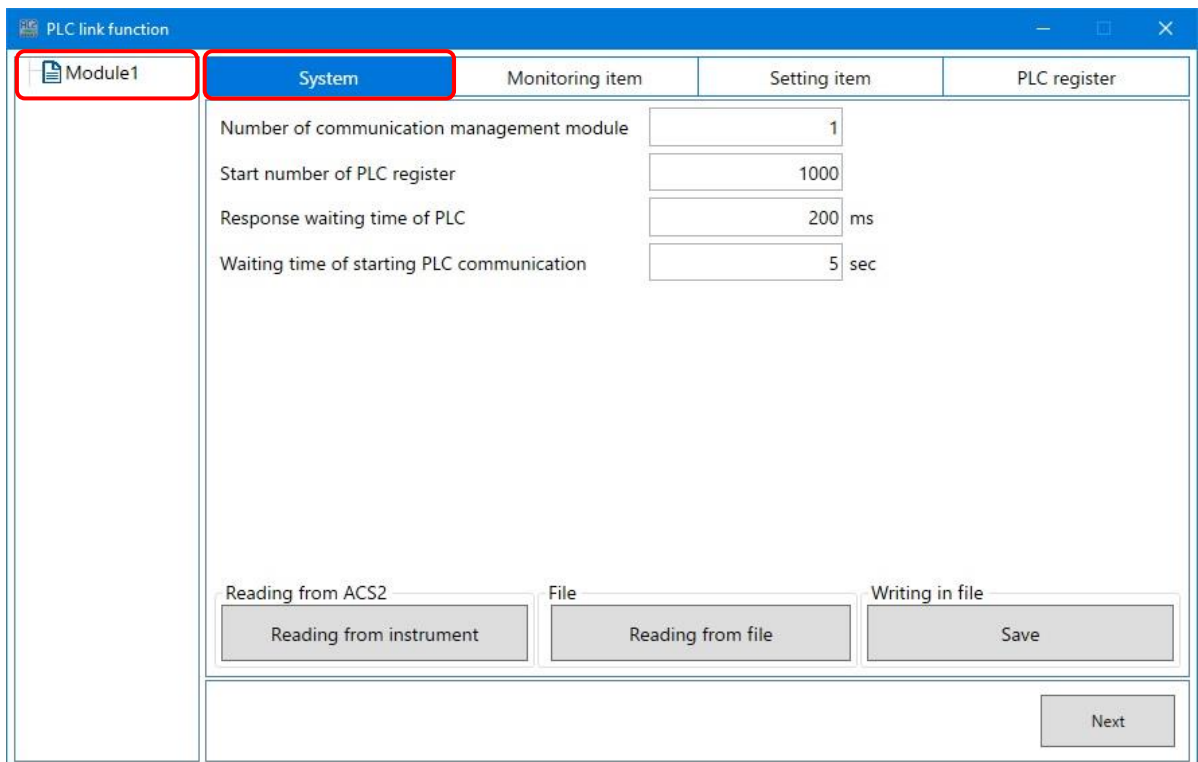

(Fig. 8.3-6)

(5) PLC Communication Parameter Specification Settings

PLC Link Initial Setup screen

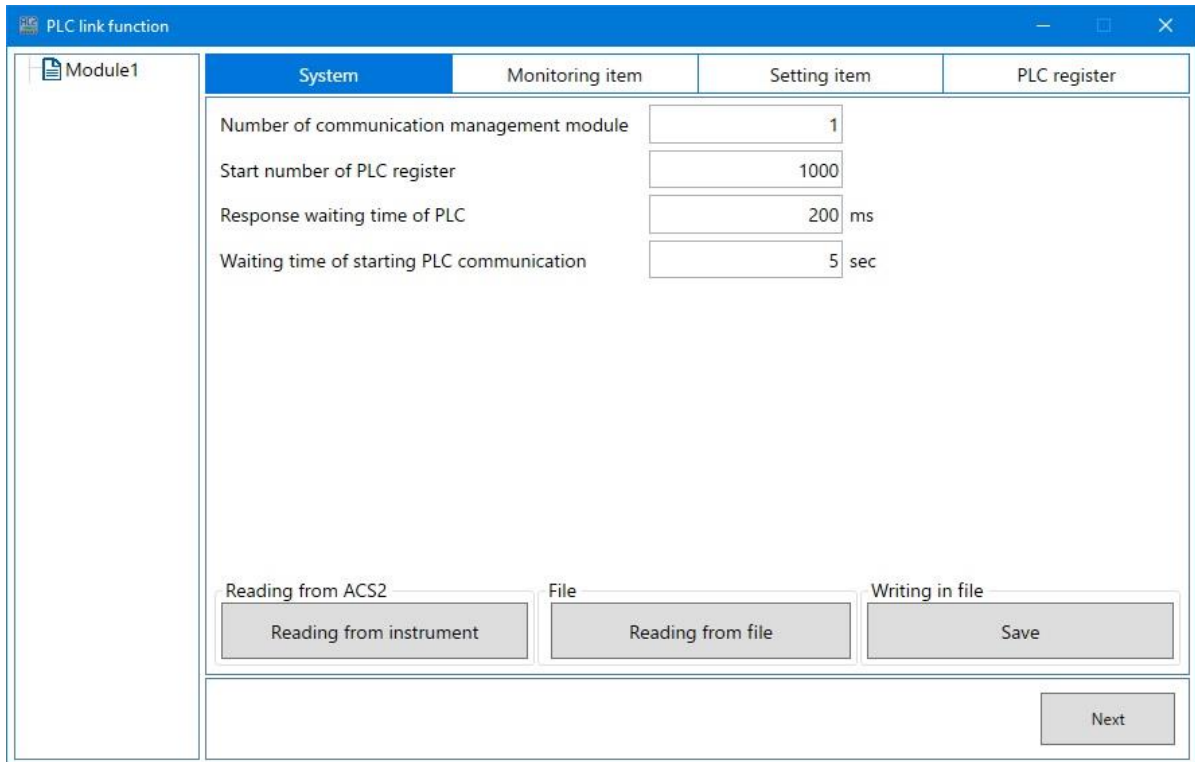

(Fig. 8.3-7)

Set the specifications by referring to the PLC Link initial setup items.

PLC Link initial setup items

Item	Settings/Selection Range	Initial value	Remarks (*)
Number of communication management module	1 to 8	1	0
Start number of PLC register	0 to 65535	1000	0
Response waiting time of PLC	100 to 3000 ms	250	1
Waiting time of starting PLC communication	1 to 255 sec	5	1
Reserved (Unused)		0	0
Monitor item 1 selection	Monitor item 1 table (P.52)	31	0
Monitor item 2 selection	Monitor item 2 table (P.53)	0	0
Reserved (Unused)		0	0
Setting item 1 selection	Setting item 1 table (P.53)	1	0
Setting item 2 selection	Setting item 2 table (P.54)	0	0
Setting item 3 selection	Setting item 3 table (P.54)	0	0
Setting item 4 selection	Setting item 4 table (P.55)	0	0
Setting item 5 selection	Setting item 5 table (P.55)	7	0
Setting item 6 selection	Setting item 6 table (P.56)	0	0
Setting item 7 selection	Setting item 7 table (P.56)	0	0
Setting item 8 selection	Setting item 8 table (P.57)	0	0
Reserved (Unused)			

(\*) 0: The values set for each ACS2 are valid items.

1: The values set for ACS2 instrument number 1 (Master) are the valid items.

- ① Number of communication management module  
Set the number of units managed by the master.  
Set the total number of units, including the master.
- ② Start number of PLC register  
Set the start number for register used in PLC communication. Fixed to D register.  
Set within the range 0 to 65535.  
For A-compatible 1C frame AnA/AnU, set within the range 0 to 8191.  
Each ACS2 unit uses a maximum of 30 registers.  
[System area: 10 registers, Monitor items: 10 registers, Setting items: 10 registers]  
When using multiple slaves, ensure register numbers do not duplicate.
- ③ Response waiting time of PLC  
Set the retransmission interval time when no response is received from the PLC.  
Set within the range of 100 to 3000 ms.
- ④ Waiting time of starting PLC communication  
After ACS2 (Master) power-on, this setting determines the time until communication with the PLC starts.  
Set within the range of 1 to 255 seconds.
- ⑤ Monitor item 1 to 2 selection  
Click the Monitor item tab or the Next button.  
The Monitor item selection screen will appear.  
Select any items from Monitor items 1 to 2. The maximum number of valid items selected is 10.  
Any items exceeding this limit will be invalid.

Monitor item 1 selection (Initial value: 31)

Bit	Selection	Description
0	1	PV reading (including differential)
1	1	MV reading
2	1	SV reading
3	1	Status flag 1
4	1	Status flag 2
5	0	Heater 1 current value reading
6	0	Heater 2 current value reading
7	0	Ambient temperature reading
8	0	Setting value memory number
9	0	Program operation run step
10	0	Program operation remaining time
11	0	Program operation number of repetitions
12	0	Error status flag
13	0	Unused
14	0	Unused
15	0	Unused

Monitor item 2 selection (Initial value: 0)

Bit	Selection	Description
0	0	Unused
1	0	Unused
2	0	Unused
3	0	Unused
4	0	Unused
5	0	Unused
6	0	Unused
7	0	Unused
8	0	Unused
9	0	Unused
10	0	Unused
11	0	Unused
12	0	Unused
13	0	Unused
14	0	Unused
15	0	Unused

⑥ Setting Item 1 to 8 selection

Click the setting item tab or the Next button.

The setting item selection screen will appear.

Select any items from setting items 1 to 8. The maximum number of valid selections is 10 items.

Any selections exceeding this limit will be invalid.

Setting Item 1 selection (Initial value: 1)

Bit	Setting Request Item No.	Selection	Description
0	1	1	SV1 setting
1	2	0	SV2 setting
2	3	0	SV3 setting
3	4	0	SV4 setting
4	5	0	Unused
5	6	0	Unused
6	7	0	Unused
7	8	0	Unused
8	9	0	Unused
9	10	0	Unused
10	11	0	Unused
11	12	0	Unused
12	13	0	Unused
13	14	0	Unused
14	15	0	Unused
15	16	0	Unused

Setting Item 2 selection (Initial value: 0)

Bit	Setting Request Item No.	Selection	Description
0	17	0	Unused
1	18	0	Unused
2	19	0	Unused
3	20	0	Unused
4	21	0	Unused
5	22	0	Unused
6	23	0	Unused
7	24	0	Unused
8	25	0	Unused
9	26	0	Unused
10	27	0	Unused
11	28	0	Unused
12	29	0	Unused
13	30	0	Unused
14	31	0	Unused
15	32	0	Unused

Setting Item 3 selection (Initial value: 0)

Bit	Setting Request Item No.	Selection	Description
0	33	0	EV1 alarm setting
1	34	0	EV1 high limit alarm setting
2	35	0	EV2 alarm setting
3	36	0	EV2 high limit alarm setting
4	37	0	EV3 alarm setting
5	38	0	EV3 high limit alarm setting
6	39	0	Heater burnout alarm setting 1
7	40	0	Heater burnout alarm setting 2
8	41	0	Loop break alarm time setting
9	42	0	Loop break alarm band setting
10	43	0	Loop break alarm dead band setting
11	44	0	Unused
12	45	0	Unused
13	46	0	Unused
14	47	0	Unused
15	48	0	Unused

Setting Item 4 selection (Initial value: 0)

Bit	Setting Request Item No.	Selection	Description
0	49	0	Fix control/program control selection
1	50	0	Step time unit selection
2	51	0	Power restore action selection
3	52	0	Program start temperature setting
4	53	0	Program control start type selection
5	54	0	Number of repetitions setting
6	55	0	Unused
7	56	0	Unused
8	57	0	AT perform selection
9	58	0	AT action model selection
10	59	0	AT bias setting
11	60	0	AT gain setting
12	61	0	AT hysteresys setting
13	62	0	Unused
14	63	0	Unused
15	64	0	Unused

Setting Item 5 selection (Initial value: 7)

Bit	Setting Request Item No.	Selection	Description
0	65	1	Block1 OUT1 proportional band setting
1	66	1	Block1 OUT1 integral time setting
2	67	1	Block1 OUT1 derivative time setting
3	68	0	Block1 OUT2 proportional band setting
4	69	0	Block1 OUT2 integral time setting
5	70	0	Block1 OUT2 derivative time setting
6	71	0	Block1 MV bias setting
7	72	0	Block1 overlap/deadband setting
8	73	0	Block2 OUT1 proportional band setting
9	74	0	Block2 OUT1 integral time setting
10	75	0	Block2 OUT1 derivative time setting
11	76	0	Block2 OUT2 proportional band setting
12	77	0	Block2 OUT2 integral time setting
13	78	0	Block2 OUT2 derivative time setting
14	79	0	Block2 MV bias setting
15	80	0	Block2 overlap/deadband setting

Setting Item 6 selection (Initial value: 0)

Bit	Setting Request Item No.	Selection	Description
0	81	0	Block3 OUT1 proportional band setting
1	82	0	Block3 OUT1 integral time setting
2	83	0	Block3 OUT1 derivative time setting
3	84	0	Block3 OUT2 proportional band setting
4	85	0	Block3 OUT2 integral time setting
5	86	0	Block3 OUT2 derivative time setting
6	87	0	Block3 MV bias setting
7	88	0	Block3 overlap/deadband setting
8	89	0	Block4 OUT1 proportional band setting
9	90	0	Block4 OUT1 integral time setting
10	91	0	Block4 OUT1 derivative time setting
11	92	0	Block4 OUT2 proportional band setting
12	93	0	Block4 OUT2 integral time setting
13	94	0	Block4 OUT2 derivative time setting
14	95	0	Block4 MV bias setting
15	96	0	Block4 overlap/deadband setting

Setting Item 7 selection (Initial value: 0)

Bit	Setting Request Item No.	Selection	Description
0	97	0	Block5 OUT1 proportional band setting
1	98	0	Block5 OUT1 integral time setting
2	99	0	Block5 OUT1 derivative time setting
3	100	0	Block5 OUT2 proportional band setting
4	101	0	Block5 OUT2 integral time setting
5	102	0	Block5 OUT2 derivative time setting
6	103	0	Block5 MV bias setting
7	104	0	Block5 overlap/deadband setting
8	105	0	Block6 OUT1 proportional band setting
9	106	0	Block6 OUT1 integral time setting
10	107	0	Block6 OUT1 derivative time setting
11	108	0	Block6 OUT2 proportional band setting
12	109	0	Block6 OUT2 integral time setting
13	110	0	Block6 OUT2 derivative time setting
14	111	0	Block6 MV bias setting
15	112	0	Block6 overlap/deadband setting

Setting Item 8 selection (Initial value: 0)

Bit	Setting Request Item No.	Selection	Description
0	113	0	Block7 OUT1 proportional band setting
1	114	0	Block7 OUT1 integral time setting
2	115	0	Block7 OUT1 derivative time setting
3	116	0	Block7 OUT2 proportional band setting
4	117	0	Block7 OUT2 integral time setting
5	118	0	Block7 OUT2 derivative time setting
6	119	0	Block7 MV bias setting
7	120	0	Block7 overlap/deadband setting
8	121	0	Block8 OUT1 proportional band setting
9	122	0	Block8 OUT1 integral time setting
10	123	0	Block8 OUT1 derivative time setting
11	124	0	Block8 OUT2 proportional band setting
12	125	0	Block8 OUT2 integral time setting
13	126	0	Block8 OUT2 derivative time setting
14	127	0	Block8 MV bias setting
15	128	0	Block8 overlap/deadband setting

⑦ ACS2 Power OFF → ON

Turn the ACS2 power OFF → ON. The set value will take effect.

The specification settings are now complete.

When connecting multiple ACS2 units, connect the tool cable to the next ACS2.

Select the connected module number (e.g., Module 2) and click the System tab.

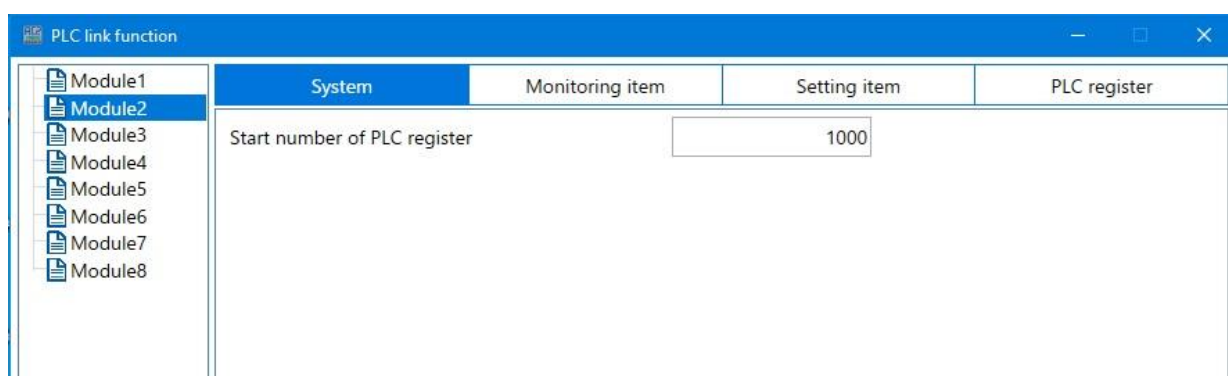

(Fig. 8.3-8)

② set the starting number for the PLC register, ⑤ select monitor items 1 to 2, and ⑥ select setting items 1 to 8. Then, ⑦ turn the ACS2 power OFF → ON.

## 8.4 Operation

This section explains the case where two ACS2 units are connected to the PLC.

Connection Example for PLC and ACS2 (Master), ACS2 (Slave)

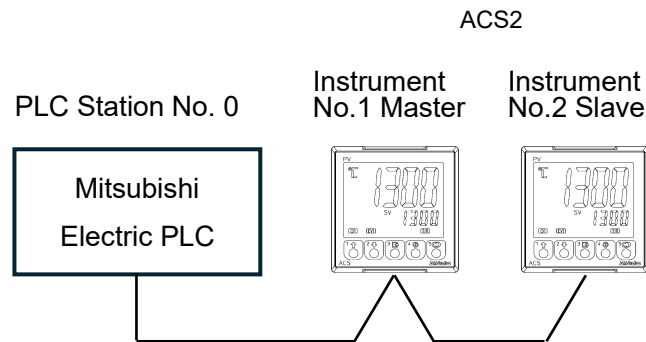

(Fig. 8.4-1)

Wiring Example for PLC and ACS2 (Master), ACS2 (Slave)

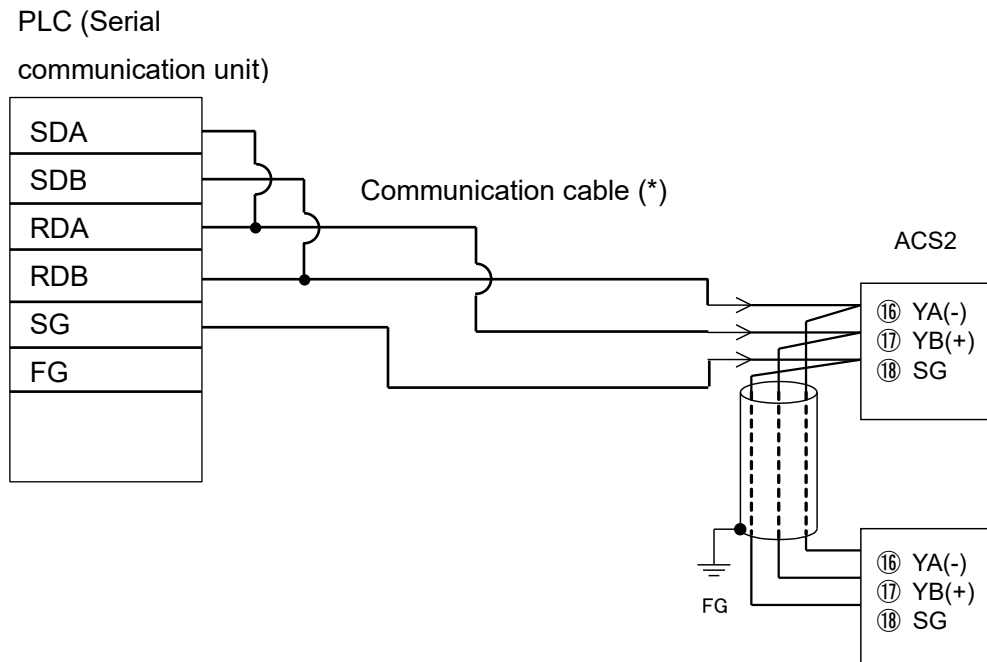

(\*): For communication cables, please contact the retailer where you made your purchase or our sales office.

(Fig. 8.4-2)

### 8.4.1 Communication Procedure

- (1) ACS2 (Instrument No. 1) acts as the master and collects valid monitor items and setting items from ACS2 (Instrument No. 2) as the slave.
- (2) After the PLC communication start wait time elapses, the ACS2 (Instrument No. 1) master writes to the PLC register when it can acquire data from the slave for the items selected in the monitor items. Additionally, it reads the items selected in the setting items from the PLC register via a setting request.

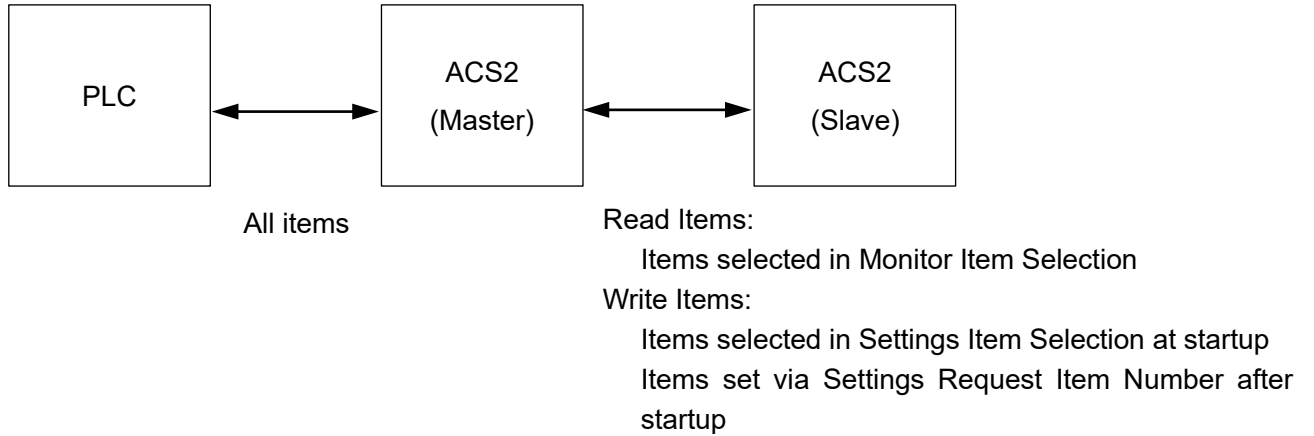

(Fig. 8.4.1-1)

### 8.4.2 Handshake between ACS2 (Master) and PLC

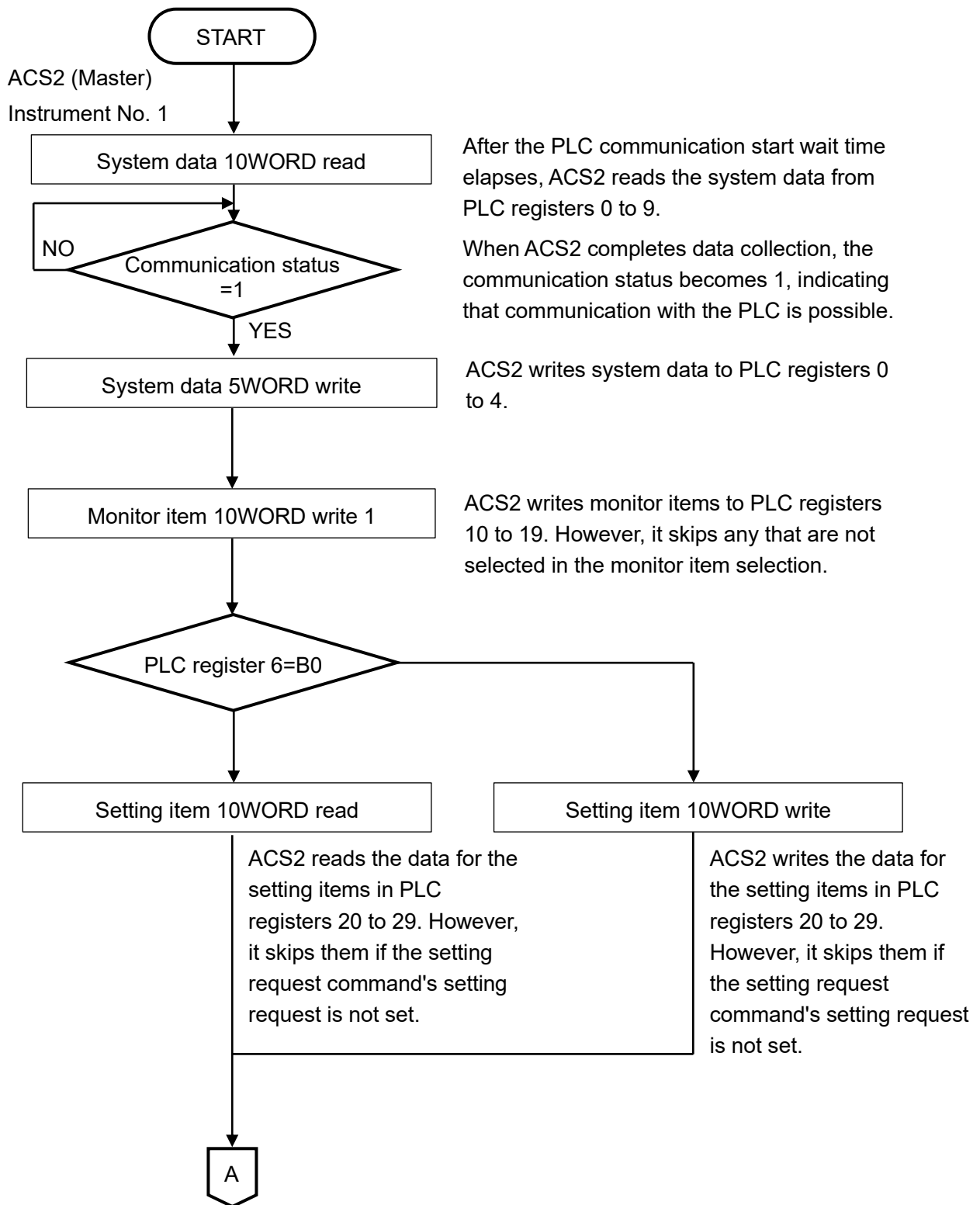

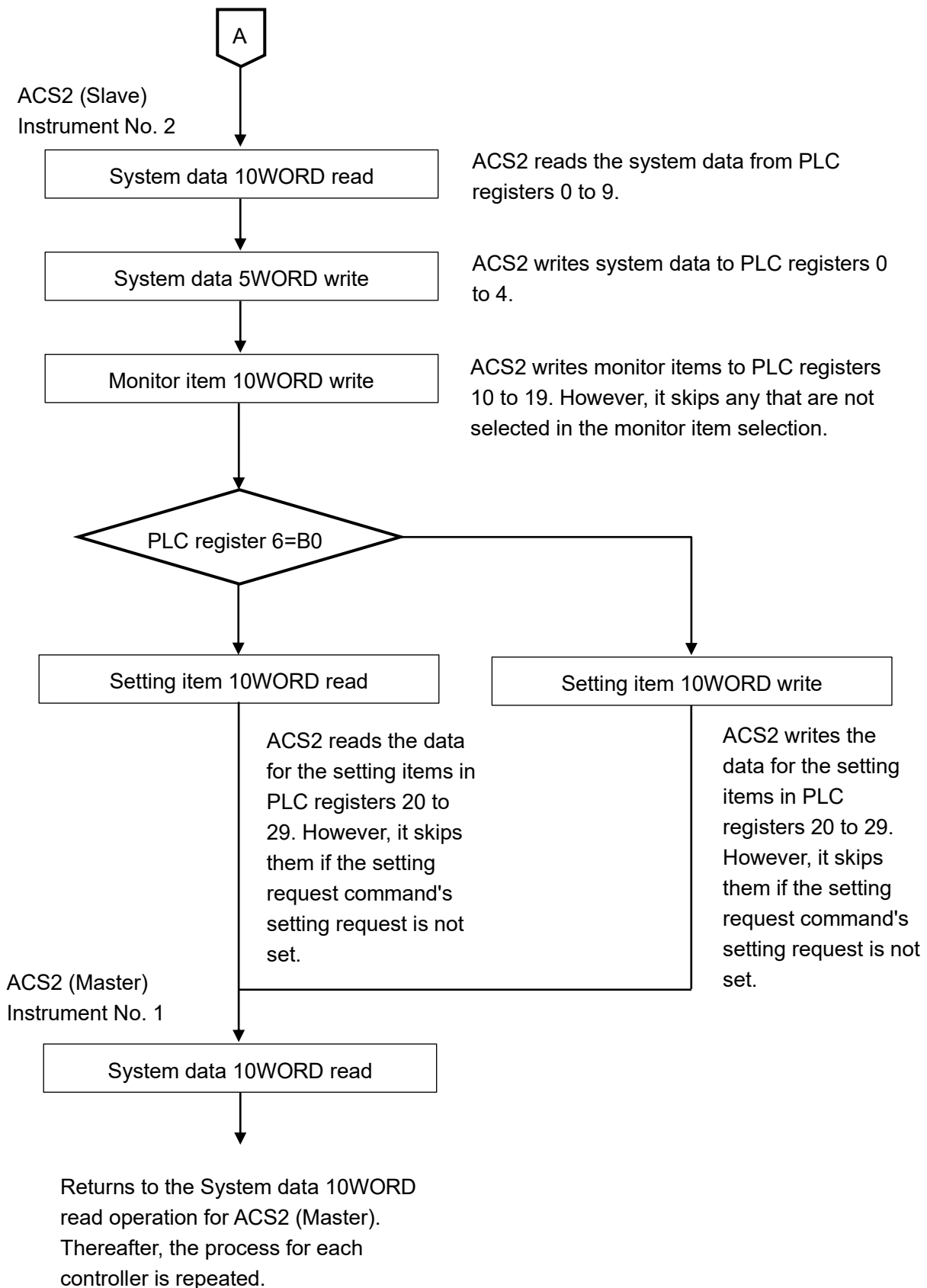

### 8.4.3 PLC Communication Data Map

The following shows the PLC communication data map when set using the initial settings example for PLC communication.

Initial Settings Example for PLC Communication

Communication Data Item		Name	ACS2 (Master) Settings	ACS2 (Slave) Settings
HEX	DEC			
012C	300	Register start number	1000	1100
012D	301	PLC response wait time	200	200
012E	302	PLC communication start wait time	5	5
012F	303	Number of communication management units	2	1
0130	304	Reserved (Unused)	0	0
0131	305	Monitor item 1 selection	31	31
0132	306	Monitor item 2 selection	0	0
0133	307	Reserved (Unused)	0	0
0134	308	Setting item 1 selection	1	1
0135	309	Setting item 2 selection	0	0
0136	310	Setting item 3 selection	0	0
0137	311	Setting item 4 selection	0	0
0138	312	Setting item 5 selection	7	7
0139	313	Setting item 6 selection	0	0
013A	314	Setting item 7 selection	0	0
013B	315	Setting item 8 selection	0	0
013C	316	Reserved (Unused)	0	0

PLC Data Register Layout

	ACS2 (Master)	ACS2 (Slave)
Information (system data) between ACS2 and PLC	1000 to 1009	1100 to 1109
Monitor items	1010 to 1014	1110 to 1114
Setting items	1015 to 1018	1115 to 1118

Detailed Information (System Data) Between ACS2 and PLC

ACS2 (Master)

Data	PLC Data Register	PLC Register Attributes	Description
Communication status	1000	RO	0: ACS2 (Master) data collection in progress 1: ACS2 (Master) data collection complete (At startup: Initial settings for each slave)
ACS2 - PLC Normal communication monitor	1001	RO	Increment counter (*1) Repeats 0 to 65535 → 0 to 65535.
ACS2 Error code	1002	RO	B0: PLC register R/W error 0: Normal 1: Abnormal B1: ACS2 (Master) communication error 0: Normal 1: Abnormal B2: ACS2 (Master) Negative acknowledgement during setting 0: Normal 1: Abnormal (Clears when clearing B0 in 1006.)
Setting request monitor	1003	RO	B0: During setting (Reflects and sets to B0 of 1006.) B1: During monitoring (Reflects and sets until B1 of 1006 is cleared.)
Reserved	1004	RO	
Setting request item number	1005	R/W	0: All items selected from settings 1 to 7 1 to 128: Selected items from settings 1 to 7 (1 data) Only the data for the selected items (1 data) will be read or written. However, since communication with the PLC is batch-processed, reading or writing will be performed for all selected items.
Setting request command (*2)	1006	R/W	B0: Set Request [PLC → ACS2(Master)] ACS2(Master) requests to read the data of the set item from the PLC register. B1: Monitor Request [ACS2(Master) → PLC] ACS2(Master) requests to write the data of the set item to the PLC register. After completing a Set Request or Monitor Request, ACS2(Master) clears each bit.
Reserved	1007	R/W	
Reserved	1008	R/W	
Reserved	1009	R/W	

(\*1): The increment counter is incremented by +1 when the ACS2 (master) sends a command. The increment value varies based on the number of active monitor items and setting items, the number of connected units, and whether a setting request is present.  
(Example) If the number of active monitor items is the initial value of 31 and only monitor units are connected:

- For 1 connected unit, the count value increases by +3.
- For 2 connected units, the count value increases by +6.

(\*2): When the setting request and monitor request are set simultaneously, processing proceeds in the following order: first the setting request [ACS2 (Master) reads PLC register data], then the monitor request (writes data to the PLC register).

If a setting request is set during a monitor request, the monitor request is discarded, and the monitor request is performed again after the setting request.

## ACS2 (Slave)

Data	PLC Data Register	PLC Register Attributes	Description
Communication status	1100	RO	0: ACS2 (Master) collecting data from ACS2 (Slave) 1: ACS2 (Master) completed collecting data from ACS2 (Slave) (At startup: Each slave's initial settings)
ACS2- PLC Normal communication monitor	1101	RO	Increment counter (*1) Repeats 0 to 65535 → 0 to 65535.
ACS2 Error code	1102	RO	B0: PLC register R/W error 0: Normal 1: Abnormal B1: Communication error between ACS2 (Master) and ACS2 (Slave) 0: Normal 1: Abnormal B2: Negative acknowledgement during setting from ACS2 (Master) to ACS2 (Slave) (Clears when clearing B0 in 1006.) 0: Normal 1: Abnormal
Setting request monitor	1103	RO	B0: During setting (Reflects and sets to B0 of 1106.) B1: During monitoring (Reflects and sets until B1 of 1106 is cleared.)
Reserved	1104	RO	
Setting request item number	1105	R/W	0: All items selected from settings 1 to 7 1 to 112: Selected items from settings 1 to 7 (1 data) Only the data for the selected items (1 data) will be read or written. However, since communication with the PLC is batch-processed, reading or writing will be performed for all selected items.
Setting request command (*2)	1106	R/W	B0: Set Request [PLC → ACS2(Master)] ACS2(Master) requests to read the data of the set item from the PLC register. B1: Monitor Request [ACS2(Master) → PLC] ACS2(Master) requests to write the data of the set item to the PLC register. After completing a Set Request or Monitor Request, ACS2(Master) clears each bit.
Reserved	1107	R/W	
Reserved	1108	R/W	
Reserved	1109	R/W	

(\*1): The increment counter is incremented by +1 when the ACS2 (master) sends a command of the ACS2 (slave).

The increment value varies based on the number of active monitor items and setting items, the number of connected units, and whether a setting request is present.

(Example) If the number of active monitor items is the initial value of 31 and only monitor units are connected:

- For 1 connected unit, the count value increases by +3.
- For 2 connected units, the count value increases by +6.

(\*2): When the setting request and monitor request are set simultaneously, processing proceeds in the following order: first the setting request [ACS2 (Master) reads PLC register data of the ACS2 (slave)], then the monitor request (writes data to the PLC register).

If a setting request is set during a monitor request, the monitor request is discarded, and the monitor request is performed again after the setting request.

Detailed Monitoring and Setting Items Between ACS2 and PLC

ACS2 (Master)

Data Item	PLC Data Register	PLC Register Attributes	Description
PV reading	1010	RO	Value within the control range [Refer to ACS2 INSTRUCTION MANUAL 5.3 Basic Operation after Power-ON (P.28)]
MV reading	1011	RO	Output low limit to Output high limit
SV reading	1012	RO	Scaling low limit to Scaling high limit
Status flag 1	1013	RO	B0: OUT1 output 0 : OFF  1 : ON B1: OUT2 output 0 : OFF  1 : ON B2: EV1 output 0 : OFF  1 : ON B3: EV2 output 0 : OFF  1 : ON B4: EV3 output 0 : OFF  1 : ON B5: Undefined (Indeterminate) B6: Undefined (Indeterminate) B7: Undefined (Indeterminate) B8: Undefined (Indeterminate) B9: Undefined (Indeterminate) B10: Control terminal short-circuit alarm 0 : OFF  1 : ON B11: Heater burnout alarm 0 : OFF  1 : ON B12: Loop break alarm 0 : OFF  1 : ON B13: Input high limit error 0: Normal  1: Abnormal B14: Input low limit error 0: Normal  1: Abnormal B15: Key operation change 0: Disabled  1: Enabled

Data Item	PLC Data Register	PLC Register Attributes	Description
Status flag 2	1014	RO	B0: Warm-up 0: Completed 1: Running B1: EI1 input 0 : OFF 1 : ON B2: EI2 input 0 : OFF 1 : ON B3: EI3 input 0 : OFF 1 : ON B4: EI4 input 0 : OFF 1 : ON B5: Power Supply 0: Instrument Power 1: USB Power B6: Undefined (Always 0) B7: Control status 0: Prohibited 1: Permitted B8: AT status 0: Stop 1: Run B9: Auto/Manual control 0: Auto control 1: Manual control B10: Remote/Local 0: Local 1: Remote B11: Control mode 0: Fixed-value control 1: Program control B12: Program control 0: Stop 1: Run B13: Wait function 0 : OFF 1 : ON B14: Hold function 0 : OFF 1 : ON B15: Pattern end output 0 : OFF 1 : ON
SV1 setting	1015	R/W	Scaling low limit to Scaling high limit

Data Item	PLC Data Register	PLC Register Attributes	Description
Block1 OUT1 Proportional band setting	1016	R/W	Except when Fast-PID control is selected When input is without decimal points: 1 to input span When input is with decimal points: 0.1 to input span For current/voltage input: 0.1 to 1000.0% When Fast-PID control is selected When input is without decimal points: 0 to input span When input is with decimal points: 0.0 to input span For current/voltage input: 0.0 to 1000.0%
Block1 OUT1 Integral time setting	1017	R/W	Except when Slow-PID control is selected 0 to 10000 sec or 0.0 to 1999.9 sec When Slow-PID control is selected 1 to 10000 sec or 0.1 to 1999.9 sec
Block1 OUT1 Derivative time setting	1018	R/W	0 to 10000 sec or 0.0 to 1999.9 sec

Control module ACS2 (Slave)

Data Item	PLC Data Register	PLC Register Attributes	Description
PV reading	1110	RO	Same as ACS2 (Master).
MV reading	1111	RO	
SV reading	1112	RO	
Status flag 1	1113	RO	
Status flag 2	1114	RO	
SV1 setting	1115	R/W	
OUT1 Proportional band setting	1116	R/W	
OUT1 Integral time setting	1117	R/W	
OUT1 Derivative time setting	1118	R/W	

#### 8.4.4 Data Exchange Between ACS2 and PLC

Data exchange between the ACS2 and the PLC is performed using the setting request item number and the setting request command.

##### (1) Setting request item number

Sets whether to transfer data for all selected items from setting items 1 to 7, or only for the selected item(s) (1 data).

0: Transfers data for all items selected in setting items 1 to 7.

1 to 112: Transfers data only for the item selected in setting items 1 to 7 (1 data).

##### (2) Setting request command

The setting request commands include setting requests and monitor requests.

B0: Setting request (PLC → ACS2)

This command instructs ACS2 to read data from the setting items in the PLC registers.

B1: Monitor request (ACS2 → PLC)

This command instructs ACS2 to write data for setting items to the PLC registers.

When the setting request and monitor request are set simultaneously, processing proceeds in the following order: first the setting request (ACS2 reads the data of the setting item from the PLC register), then the monitor request (writes the data of the setting item to the PLC register).

If the setting request is set during the monitor request, the monitor request is discarded, and the monitor request is performed again after the setting request.



### Caution

When the data is being set, first write all the data for the setting items to the PLC register.

If you change the setting items of the ACS2 without writing all the data for the setting items, they may be overwritten with undefined values, potentially causing malfunctions. Please be careful.

#### Data setting procedure

Assume that setting item 4, B8 (AT Run/Stop selection), has been set from its default value in the initial setting.

When selecting the AT Run in the ACS2 AT Run/Stop selection

- (1) Set the setting request item number to 0

To write all setting data to the PLC register, set 0 to 1005 (setting request item number).

- (2) Set B1 (monitor request) in the setting request command

Set 1 (decimal: 2) to B1 (monitor request) in 1006 (setting request command).

ACS2 will begin writing the setting item data to the PLC register.

- (3) Check B1 (monitor request) in the setting request command

Once the data for the setting items has been written to the PLC register, the B1 (monitor request) of 1006 (setting request command) is cleared.

- (4) Data Settings

Set 1 (AT Run) to PLC register 1016.

- (5) Set 1 to the setting request item number

To read the data for the AT Run/Stop selection in the PLC register, set 57 to 1005 (setting request item number).

- (6) Set the B0 (setting request) command

Set 1 (decimal: 1) to B0 (setting request) in 1006 (setting request command).

ACS2 will begin reading the data for the PLC register setting items.

- (7) Check the B0 (setting request) command

Once the data for the setting items has been read into the PLC register, the B0 (setting request) of 1006 (setting request command) is cleared.

## Operation Examples for Reading PV and Writing SV

### Explanation Conditions:

This example involves reading and writing the PV and target value (SV1) setting 1 for ACS2 (Master) and ACS2 (Slave).

PLC registers shall be assigned as follows: 1000: ACS2 (Master), 1100: ACS2 (Slave).

(1) Data flow and flag operations to synchronize PLC registers with ACS2 set values when power is ON

- ① Write 0 to D1005. [Select all setting items set via the PLC link function (in this case, only target value (SV1) setting 1)]
- ② Write 1 to D1006. [Specify data transfer from PLC to ACS2 (Master)]
- ③ Write the target value (SV1) setting 1 for ACS2 (Master) to D1012.
- ④ ACS2 (Master) writes 0 to D1006.
- ⑤ Write 0 to D1105. [Select all setting items set via the PLC link function (in this case, only target value (SV1) setting 1)]
- ⑥ Write 1 to D1106. [Specify data transfer from PLC to ACS2 (Master)]
- ⑦ ACS2 (Master) reads the SV from ACS2 (Slave) and writes it to D1112.
- ⑧ ACS2 (Master) writes 0 to D1106.

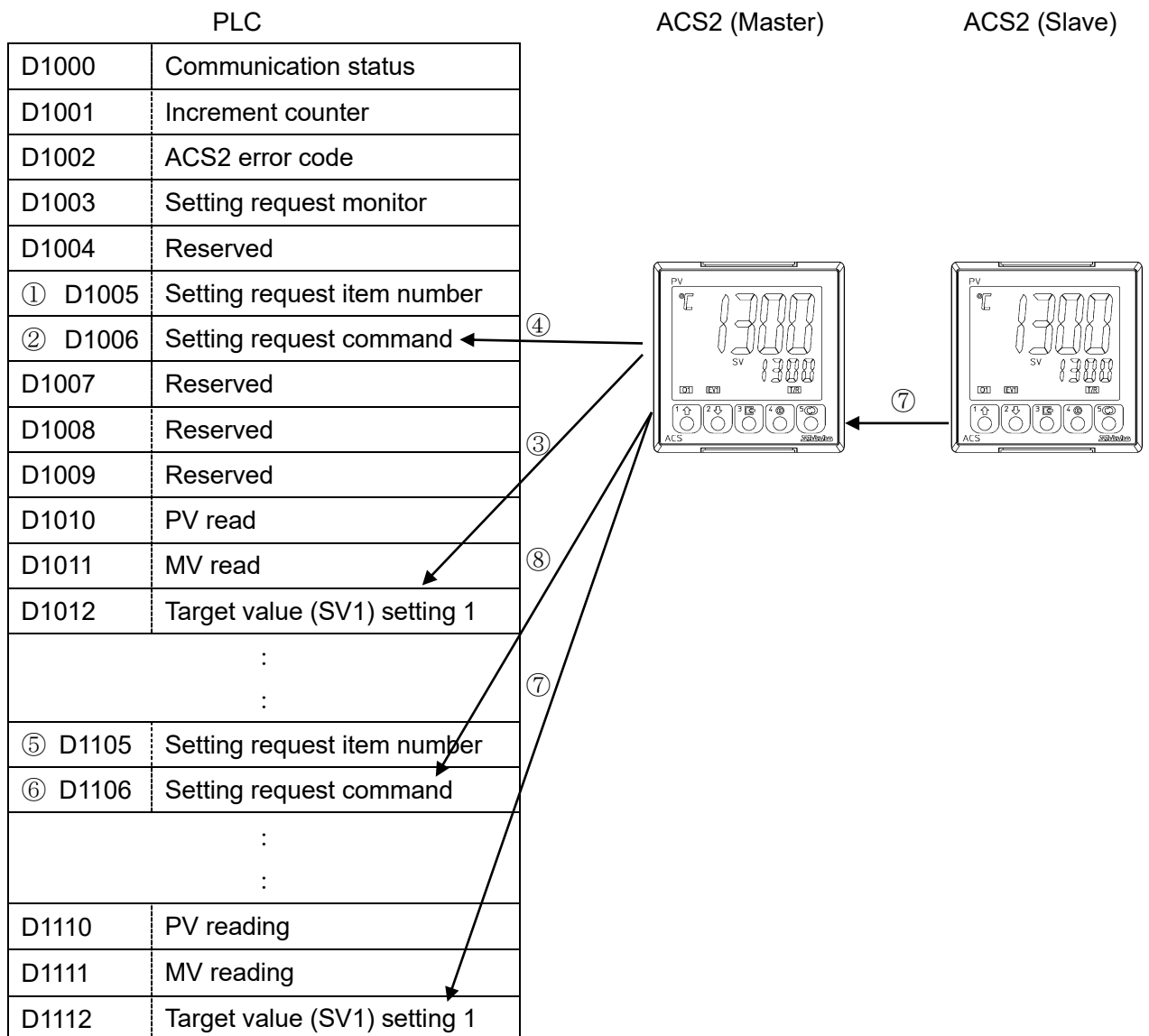

(Fig. 8.4.5-1)

(2) Data flow and flag operations during PV reading

- ① ACS2 (Master) reads the system data from PLC registers D1000 to D1009.
- ② ACS2 (Master) writes the system data to PLC registers D1000 to D1004.
- ③ ACS2 (Master) writes the PV to PLC register D1010.
- ④ ACS2 (Master) reads the system data from PLC registers D1100 to D1109.
- ⑤ ACS2 (Master) writes the system data to PLC registers D1100 to D1104.
- ⑥ ACS2 (Master) reads the PV from ACS2 (Slave) and writes the PV to PLC register D1110.

※ Only the PLC link function settings via the console software are required; flag operations are not necessary.

The PV of each register is updated at the timings indicated above in ① to ⑥.

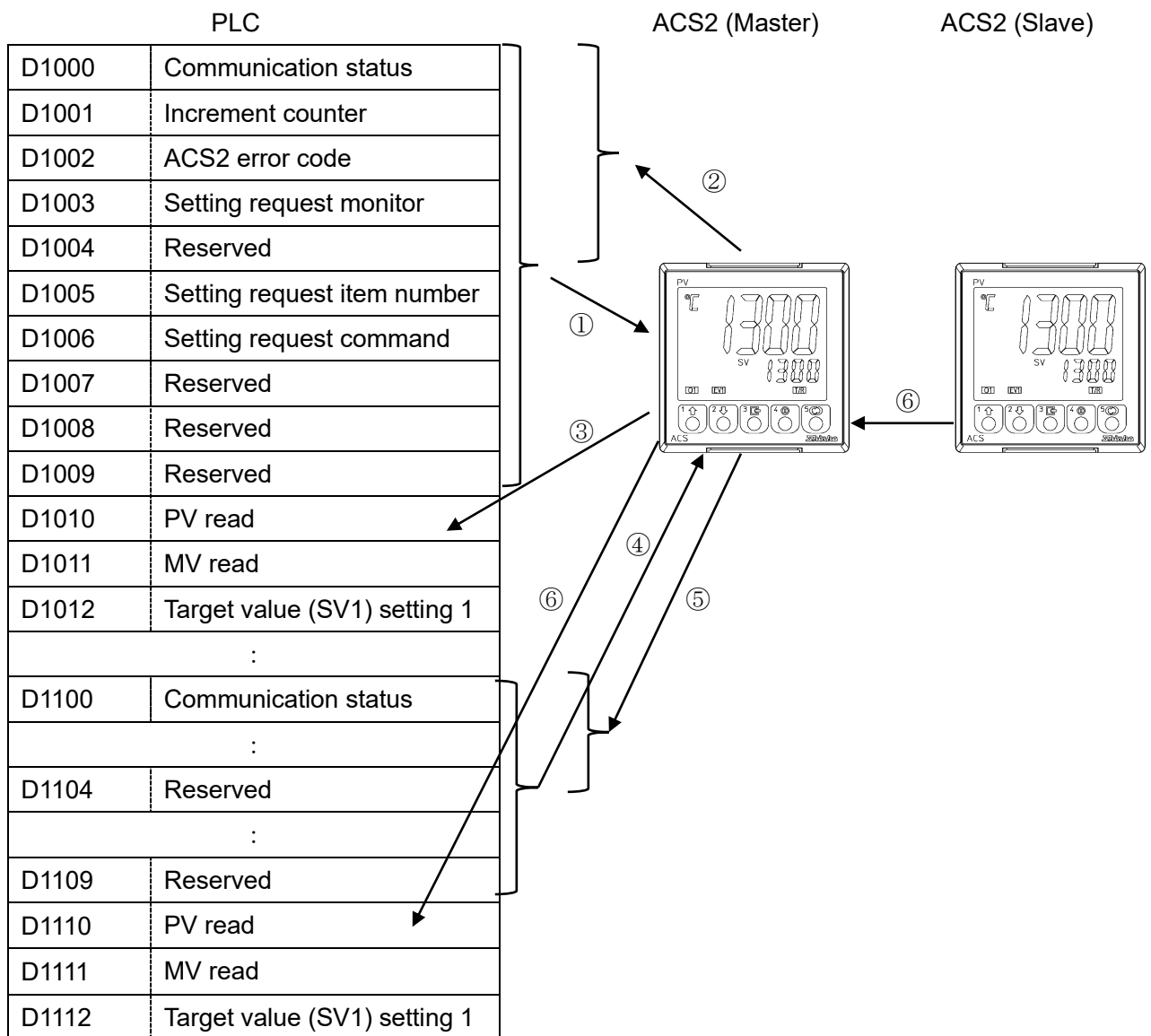

(Fig. 8.4.5-2)

(3) Data flow and flag operations during SV writing

- ① Change D1012 [SV of ACS2 (Master)].
- ② Write 0 or 1 to D1005.  
0: Select all setting items set via the PLC link function [In this case, only target value (SV1) setting 1]  
1: Only target value (SV1) setting 1 (see P.53)
- ③ Write 1 to D1006. [Specify data transfer from PLC → ACS2 (Master)]
- ④ ACS2 (Master) writes the data from D1012 to SV of ACS2 (Master).
- ⑤ ACS2 (Master) writes 0 to D1006.
- ⑥ Change D1112 [SV of ACS2 (Master)].
- ⑦ Write 0 or 6 to D1105.
- ⑧ Write 1 to D1106. [Specify data transfer from PLC → ACS2 (Master)]
- ⑨ ACS2 (Master) writes the data from D1112 to SV of ACS2 (Slave).
- ⑩ ACS2 (Master) writes 0 to D1106.

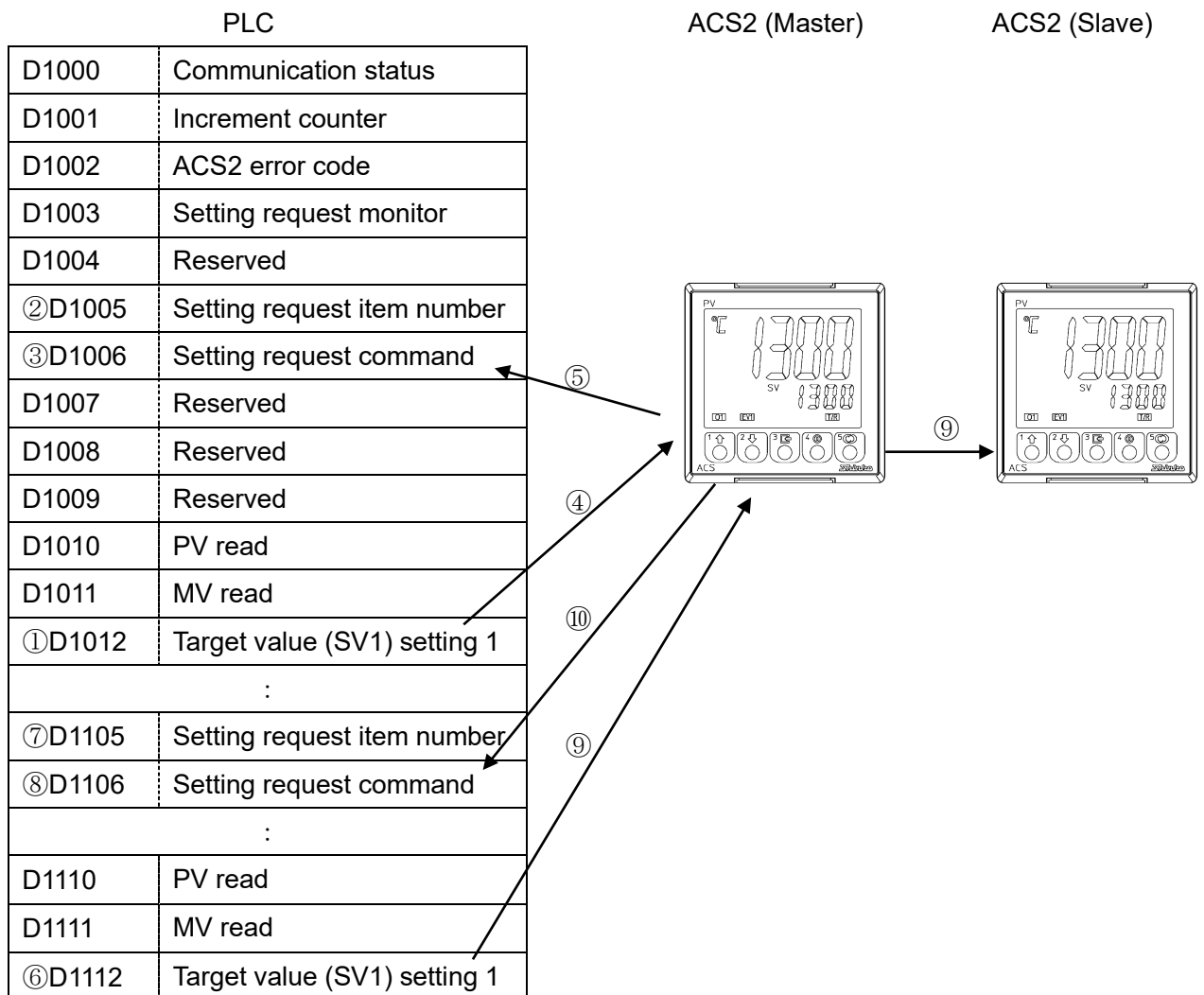

(Fig. 8.4.5-3)

# 9. SVTC (Setting Value Digital Transmission)

When select SVTC in the serial communication protocol selection for serial communication, it can combine it with our digital indicating controller with communication function [with serial communication (OP: C5, C5W)] to digitally transmit the setting value.

Also, when select Shinko Protocol in the communication protocol selection, it can receive the step SV in combination with our programmable controller [PCA1 or PCB1 (select setting value digital transmission in communication protocol selection)].

Update cycle: 250 ms

## 9.1 When Selecting SVTC in Communication Protocol Selection

### 9.1.1 Wiring

Connect the communication function controller to the SG and YA(-), YB(+) terminals of this instrument.

Up to 31 units can be connected.

An example of connecting the communication function controller to this instrument is shown in Fig. 9.1.1-1.

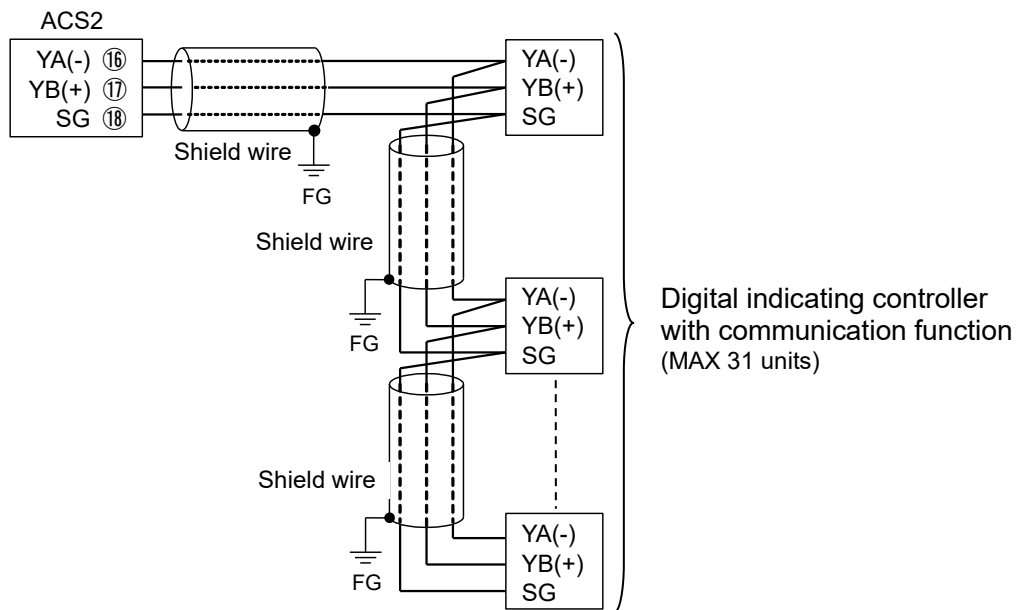

Fig. 9.1.1-1

### 9.1.2 Setting Method of Instrument

(1) This instrument's settings

Select the following items within the communication settings group.

Refer to "3. Setting Communication Parameters (P.4 to 5)".

- Select SVTC in the communication protocol selection.
- Select the communication speed, data bits/parity, and stop bits.

(2) Checking the settings for the digital indicating controller with communication function

- Ensure the communication protocol selection is set to the Shinko Protocol.
- Ensure the communication speed, data bits/parity, and stop bits match those of this instrument.

(3) Start of setting value digital transmission

Input the program setting value and assign the program mode RUN/STOP function to either the OUT/OFF key, PF key, or EVT input to this instrument.

When executing the program using either the OUT/OFF key, PF key, or EVT input, the step SV of this instrument is sent to the digital indicating controller with communication function.

During program control stop (standby), "0" is sent to the digital indicating controller with communication function.

## 9.2 When Selecting Shinko Protocol in Communication Protocol Selection

### 9.2.1 Wiring

For PCA1 or PCB1, connect YA(-) to YA(-), YB(+) to YB(+), and SG to SG respectively.

A maximum of 31 units can be connected.

Connection example between PCB1 and this instrument is shown in Fig. 9.2.1-1.

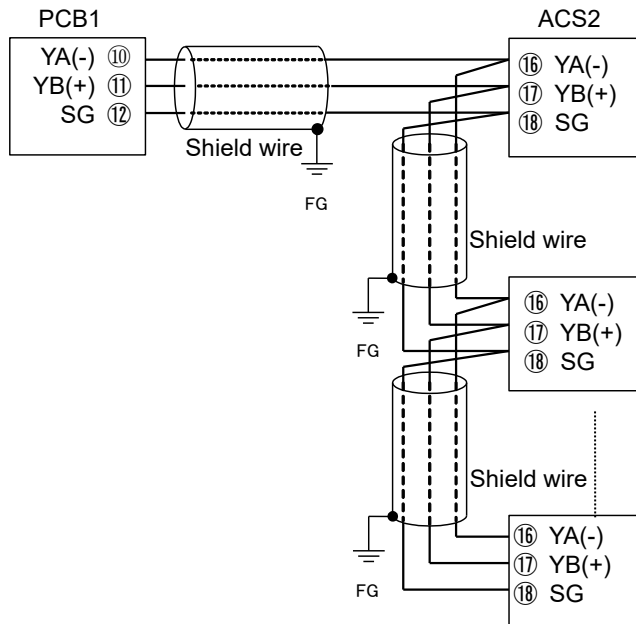

(Fig. 9.2.1-1)

### 9.2.2 Setting Method of Instrument

(1) PCA1 or PCB1 settings

- Select setting value digital transmission in the communication protocol selection.
- Select the communication speed, data bits/parity, and stop bits.

(2) This instrument's settings

Setting (Select) the following items within the communication settings group.

Refer to "3. Setting Communication Parameters (P.4 to 5)".

- Ensure the communication protocol selection is set to the Shinko Protocol.
- Ensure the communication speed, data bits/parity, and stop bits match those of PCA1 or PCB1.

(3) Start of setting value digital transmission

Enter the program setting value into PCA1 or PCB1.

Pressing the RUN key to execute the program sends the step SV from PCA1 or PCB1 to this instrument.

If SVTC bias setting is set, the SV value becomes the value received via the SVTC command (the step SV from PCA1 or PCB1) plus the SVTC bias value.

During program control stop (standby), "0" is sent to this instrument.

# 10. Specifications

Cable length	1.2 km (Max.), Cable resistance: Within 50 $\Omega$ (Terminators are not necessary, but if used, use 120 $\Omega$ minimum on both sides.)		
Communication line	EIA RS-485		
Communication method	Half-duplex communication		
Communication speed	9600, 19200, 38400, 56800, 115200bps (Selectable by keypad)		
Synchronization method	Start-stop synchronization		
Code form	ASCII, binary		
Data bit/Parity	7, 8 / Even, Odd, No parity (Selectable by keypad)		
Stop bit	1, 2 (Selectable by keypad)		
Communication protocol	Shinko protocol/MODBUS RTU/MC protocol/SVTC (Selectable by keypad)		
Data format	Data format varies depending on the communication protocol as follows.		
	Communication Protocol	Shinko Protocol	MODBUS RTU
	Start bit	1	1
	Data bit	7 (8) Selectable	8
	Parity	Even (No parity, Odd) Selectable	No parity (Even, Odd) Selectable
	Stop bit	1 (2) Selectable	1 (2) Selectable
Number of connectable units	Max 31 units to 1 host computer		
Error correction	Command request repeat system		
Error detection	Checksum (Shinko protocol), CRC-16 (MODBUS RTU)		
Response delay time setting	After receiving a command from the host, the response can be delayed. Setting range: 0 to 1000 ms		
SV digital transmission	<p>Selecting SV digital transmission in the serial communication protocol selection allows digital transmission of setting values when combined with a digital indicating controller (with serial communication (optional: C5, C5W)).</p> <p>If the sending side of the SV digital transmission exceeds the scaling range of the digital indicating controller, it is limited to the scale range of the digital indicating controller.</p> <p>Update cycle: 250 ms</p>		
SVTC bias setting	<p>ACS2 digital external setting (active when Shinko protocol is selected)</p> <p>Receives digital setting values from the SVTC program controller option.</p> <p>The control target value is the value received via the SVTC command plus the SVTC bias value.</p> <p>The control target value is the value received via the SVTC command plus the SVTC bias value, constrained within the range defined by the scaling lower limit setting to scaling upper limit setting.</p> <p>Setting range: Equivalent to <math>\pm 20\%</math> of the input span</p>		
PLC link function	<p>When MC Protocol is selected in the communication protocol selection, the PLC link function (programless communication function) can be used.</p> <p>This function establishes a serial communication connection with Mitsubishi Electric's "Q Series" PLC and uses the PLC's communication protocol to write and read various data to/from PLC registers.</p> <p>The communication protocol uses "QW" and "QR" commands. It is intended for PLCs that can use A-compatible 1C frame AnA/AnU common commands (QR/QW).</p> <p>Initial setup is performed in the console software by specifying the PLC register</p>		

	<p>address, the monitor item linked to the register address, and the setting items. ACS2 periodically writes to the PLC registers using the QW command for the specified monitor items, constantly updating the register values.</p> <p>Additionally, it reads the specified setting items from the PLC registers using the QR command in response to a setting request. If the read data changes, ACS2 updates the setting value.</p> <p>Set the master device number to 1 and the slave device numbers to 2 through 8.</p> <p>Set the PLC station number to 0 and the PC number to 255 (fixed).</p>
--	---

# 11. Troubleshooting

Check that power is being supplied to the master and slave that customers use. If communication failure still occurs, check the following.

Problem	Possible Cause	Solution
Communication failure	Communication cable is not securely connected, or is disconnected/defective.	Check the communication cable and connector.
	Incorrect wiring of the communication cable and/or connector	Check the communication cable and connector. Refer to Section '2. Wiring' (p. 2, 3).
	Imperfect contact between the communication cable and the connector, or between the communication connector and instrument port	Check the communication cable and connector.
	Communication speed of the slave does not match that of the master.	Set the same communication speed on the master and the slave. Refer to Section '3. Setting Communication Parameters' (p. 4, 5).
	The data bit, parity and stop bit of the master do not correspond to those of the slave.	Set the same data bit, parity and stop bit on the master and the slave. Refer to Section '3. Setting Communication Parameters' (p. 4, 5).
	The instrument number (address) of the slave does not correspond to that of the command.	Check the instrument number (address) of the slave and the command. Refer to Section '3. Setting Communication Parameters' (p. 4, 5).
	The instrument numbers (addresses) are duplicated in multiple slaves.	Check that each slave has a different instrument number (address). Refer to Section '3. Setting Communication Parameters' (p. 4, 5).
	Make sure that the program is appropriate for the transmission timing.	Check the program. Refer to Section '4. Communication Procedure' (p.6).
Although communication is occurring, the response is negative acknowledgement.	A non-existent command code has been sent.	Check the command code.
	The Write command data exceeds the setting range of the slave.	Check the setting range of the slave.
	The controller cannot be written when functions such as AT are performing.	Check the slave status.
	The ACS2 is in front keypad operation setting mode.	Return the controller to RUN mode.

**SHINKO TECHNOS CO., LTD.**  
**OVERSEAS DIVISION**

Head Office: 2-5-1, Senbahigashi, Minoo, Osaka, 562-0035, Japan

[URL] <https://shinko-technos.co.jp/e/>

Tel: +81-72-727-6100

[E-mail] [overseas@shinko-technos.co.jp](mailto:overseas@shinko-technos.co.jp)

Fax: +81-72-727-7006