

This manual contains instructions for communication functions of the AER-101-TU.

To prevent accidents arising from the misuse of this instrument, please ensure the operator receives this manual.

Warning

Turn the power supply to the instrument off before wiring or checking. Working on or touching the terminal with the power switched on may result in severe injury or death due to electrical shock.

1. System Configuration

System configuration example using Communication converter IF-400 and USB communication cable CMC-001-1

When using Communication converter IF-400

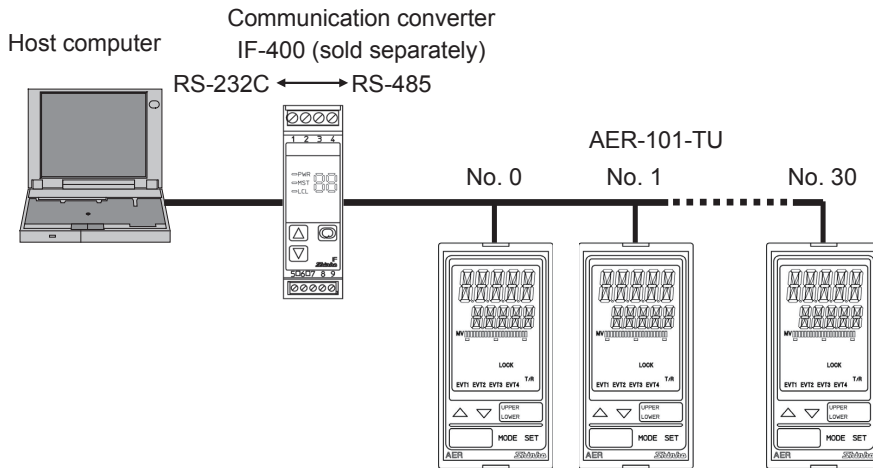

(Fig. 1-1)

When using USB communication cable CMC-001-1

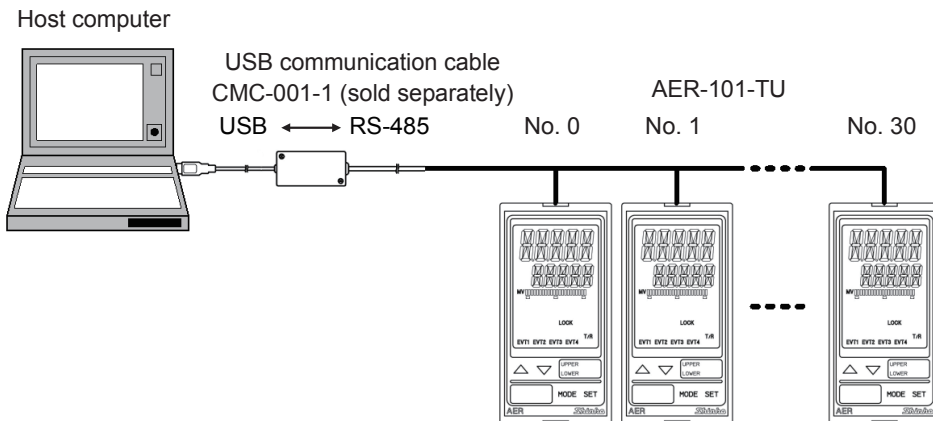

(Fig. 1-2)

2. Wiring

The following shows a connection example using Communication Converter IF-400 (sold separately) and USB communication cable CMC-001-1.

Connection between IF-400 and AER-101-TU

Use a communication cable CDM (sold separately).

Connect the modular jack and (Y-type terminal 4) of IF-400 to (13 YA) of AER-101-TU.

Connect (Y-type terminal 3) of IF-400 to (14 YB) of AER-101-TU.

Connect (Y-type terminals 1 and 6) of IF-400 to (15 SG) of AER-101-TU.

Connection between CMC-001-1 and AER-101-TU

Use a USB communication cable CMC-001-1 (sold separately).

Connect USB port of the host computer and [Y-type terminal YA (-)] to (13 YA) of AER-101-TU.

Connect [Y-type terminal YB (+)] of CMC-001-1 to (14 YB) of AER-101-TU.

Connect (Y-type terminals COM) to (15 SG) of AER-101-TU.

Connection between AER-101-TU and AER-101-TU

Using a shield wire, connect terminals (13 YA) to (13 YA), (14 YB) to (14 YB), (15 SG) to (15 SG) respectively.

• When using communication converter IF-400

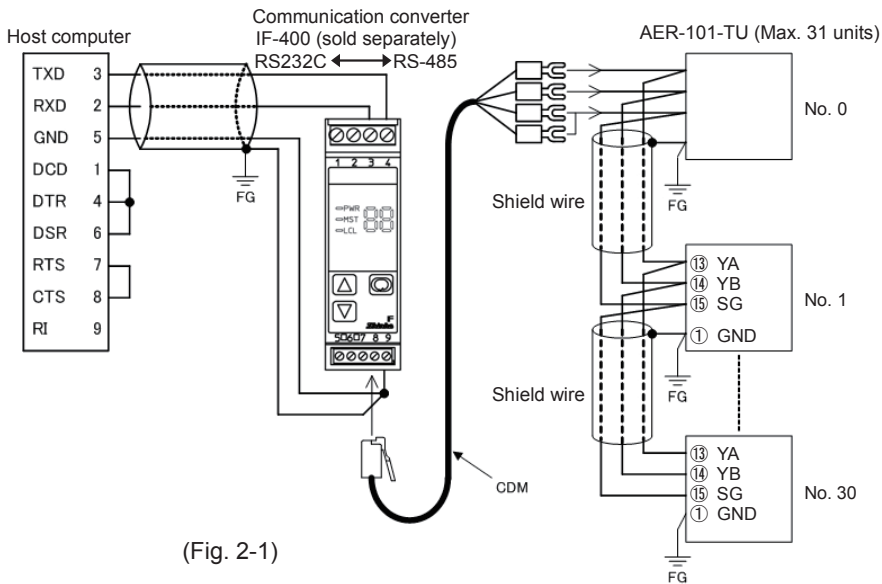

(Fig. 2-1)

• When using USB communication cable CMC-001-1

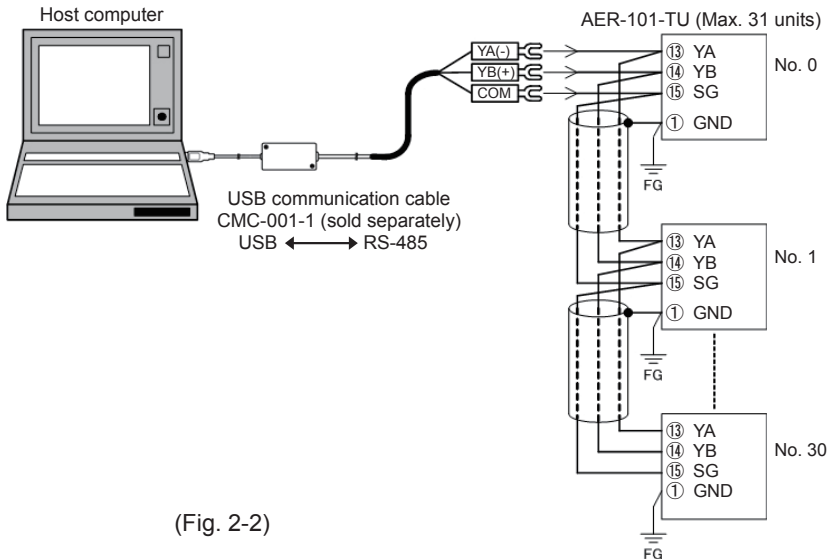

(Fig. 2-2)

Shield Wire

Connect only one end of the shield to the FG or GND terminal to avoid a ground loop. If both ends of the shield wire are connected to the FG or GND terminal, the circuit will be closed, resulting in a ground loop. This may cause noise. Be sure to ground the FG or GND terminal.

Recommended cable: OTSC-VB 2PX0.5SQ (made by Onamba Co., Ltd.) or equivalent (use a twisted pair cable.)

Terminator (Terminal Resistor)

Communication converter IF-400 (sold separately) has a built-in terminator.

The terminator is mounted at the end of the wire when connecting multiple peripheral devices to a personal computer. The terminator prevents signal reflection and disturbance.

Do not connect a terminator to the communication line because each AER-101-TU has built-in pull-up and pull-down resistors.

3. Setting Communication Parameters

Communication parameters can be set in the Communication Group.

To enter the Communication Group, follow the procedure below.

- (1) *COMM* Press the **MODE** key 4 times in Turbidity/SS Display Mode.
- (2) *CMHL* Press the **SET** key. The unit enters Communication Group, and “Communication protocol” will appear.
- (3) Make a selection using the **△** or **▽** key, and register the selection by pressing the **SET** key.

| Character | Setting Item, Function, Setting Range | Factory Default |
|----------------------------|--|-----------------|
| <i>CMHL</i> <i>NaML</i> | Communication protocol • Selects communication protocol. • <i>NaML</i> : Shinko protocol <i>ModR</i> : MODBUS ASCII mode <i>ModR</i> : MODBUS RTU mode | Shinko protocol |
| <i>CMNo</i> □□□□ | Instrument number • Sets the instrument number of this unit. (The instrument numbers should be set one by one when multiple instruments are connected in Serial communication, otherwise communication is impossible.) • Setting range: 0 to 95 | 0 |
| <i>CMSP</i> □□□□ | Communication speed • Selects a communication speed equal to that of the host computer. • □□□□96: 9600 bps □□□□192: 19200 bps □□□□384: 38400 bps | 9600 bps |
| <i>CMFP</i> <i>7EVN</i> | Data bit/Parity • Selects data bit and parity. • <i>8NoN</i> : 8 bits/No parity <i>7NoN</i> : 7 bits/No parity <i>8EVN</i> : 8 bits/Even <i>7EVN</i> : 7 bits/Even <i>8odd</i> : 8 bits/Odd <i>7odd</i> : 7 bits/Odd | 7 bits/Even |
| <i>CMSP</i> □□□□ | Stop bit • Selects the stop bit. • □□□□1: 1 bit □□□□2: 2 bits | 1 bit |

- (4) Press the **SET** key. The unit will revert to Turbidity/SS Display Mode.

4. Communication Procedure

Communication starts with command transmission from the host computer (hereafter Master) and ends with the response of the AER-101-TU (hereafter Slave).

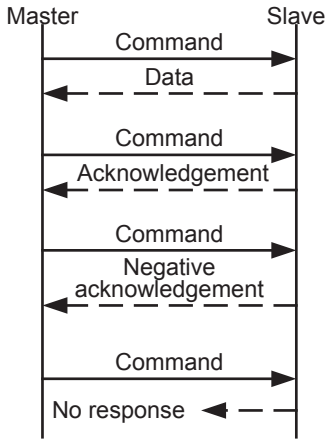

(Fig.4-1)

- **Response with data**

When the master sends the reading command, the slave responds with the corresponding set value or current status.

- **Acknowledgement**

When the master sends the setting command, the slave responds by sending acknowledgement after the processing is terminated.

- **Negative acknowledgement**

When the master sends a non-existent command or value out of the setting range, the slave returns a negative acknowledgement.

- **No response**

The slave will not respond to the master in the following cases:

- Global address (Shinko protocol) is set.
- Broadcast address (MODBUS protocol) is set.
- Communication error (framing error, parity error)
- Checksum error (Shinko protocol), LRC discrepancy (MODBUS ASCII mode), CRC-16 discrepancy (MODBUS RTU mode)

Communication Timing of the RS-485

Master Side (Take note while programming)

When the master starts transmission through the RS-485 communication line, the master is arranged so as to provide an idle status (mark status) transmission period of 1 or more characters before sending the command to ensure synchronization on the receiving side.

Set the program so that the master can disconnect the transmitter from the communication line within a 1 character transmission period after sending the command in preparation for reception of the response from the slave.

To avoid collision of transmissions between the master and the slave, send the next command after carefully checking that the master has received the response.

If a response to the command is not returned due to communication errors, set the Retry Processing to send the command again. (It is recommended to execute Retry twice or more.)

Slave Side

When the slave starts transmission through the RS-485 communication line, the slave is arranged so as to provide an idle status (mark status) transmission period of 1 or more characters before sending the response to ensure synchronization on the receiving side.

The slave is arranged so as to disconnect the transmitter from the communication line within a 1 character transmission period after sending the response.

5. Shinko Protocol

5.1 Transmission Mode

Shinko protocol is composed of ASCII codes.

Hexadecimal (0 to 9, A to F), which is divided into high order (4-bit) and low order (4-bit) out of 8-bit binary data in command is transmitted as ASCII characters.

Data format Start bit: 1 bit
 Data bit: 7 bits
 Parity: Even
 Stop bit: 1 bit

Error detection: Checksum

5.2 Command Configuration

All commands are composed of ASCII.

The data (set value, decimal number) is represented by hexadecimal numbers.

Negative numbers are represented in 2's complement.

Numerals written below the command represent number of characters.

(1) Setting Command

| | | | | | | | |
|--------------|---------|-------------------|--------------------|-----------|------|----------|-----------------|
| Header (02H) | Address | Sub address (20H) | Command type (50H) | Data item | Data | Checksum | Delimiter (03H) |
| 1 | 1 | 1 | 1 | 4 | 4 | 2 | 1 |

(2) Reading Command

| | | | | | | |
|--------------|---------|-------------------|--------------------|-----------|----------|-----------------|
| Header (02H) | Address | Sub address (20H) | Command type (20H) | Data item | Checksum | Delimiter (03H) |
| 1 | 1 | 1 | 1 | 4 | 2 | 1 |

(3) Response with Data

| | | | | | | | |
|--------------|---------|-------------------|--------------------|-----------|------|----------|-----------------|
| Header (06H) | Address | Sub address (20H) | Command type (20H) | Data item | Data | Checksum | Delimiter (03H) |
| 1 | 1 | 1 | 1 | 4 | 4 | 2 | 1 |

(4) Acknowledgement

| | | | |
|--------------|---------|----------|-----------------|
| Header (06H) | Address | Checksum | Delimiter (03H) |
| 1 | 1 | 2 | 1 |

(5) Negative Acknowledgement

| | | | | |
|--------------|---------|------------|----------|-----------------|
| Header (15H) | Address | Error code | Checksum | Delimiter (03H) |
| 1 | 1 | 1 | 2 | 1 |

Header: Control code to represent the beginning of the command or the response. ASCII codes are used.

Setting command, Reading command: STX (02H) fixed

Response with data, Acknowledgement: ACK (06H) fixed

Negative acknowledgement: NAK (15H) fixed

Instrument number (Address): Numbers by which the master discerns each slave.

Instrument numbers 0 to 94 and Global address 95.

ASCII codes (20H to 7FH) are used by adding 20H to instrument numbers 0 to 95 (00H to 5FH).

95 (7FH) is called the Global address, which is used when the same command is sent to all the slaves connected. However, a response is not returned.

Sub address: 20H fixed

Command type: Code to discern Setting command (50H) and Reading command (20H)

- Data item:** Classification of the command object.
Composed of 4-digit hexadecimal numbers, using ASCII.
[Refer to “7. Communication Command Table” (pp.11 to 16).]
- Data:** The contents of data (set value) differ depending on the setting command.
Composed of 4-digit hexadecimal numbers, using ASCII.
[Refer to “7. Communication Command Table” (pp.11 to 16).]
- Checksum:** 2-character data to detect communication errors. (Refer to “5.3 Checksum Calculation”).
- Delimiter:** Control code to represent the end of command.
ASCII code ETX (03H) fixed.
- Error code:** Represents an error type using ASCII.

| Error Code | Contents |
|------------|--|
| 1 (31H) | Non-existent command |
| 2 (32H) | Not used |
| 3 (33H) | Setting outside the setting range |
| 4 (34H) | Status unable to be set (e.g. During Turbidity/SS sensor calibration mode, or Zero/Span output signal adjustment mode) |
| 5 (35H) | During setting mode by keypad operation |

5.3 Checksum Calculation

Checksum is used to detect receiving errors in the command or data.

Set the program for the master side as well to calculate the checksum of the response data from the slaves so that communication errors can be checked.

The ASCII code (hexadecimal) corresponding to the characters which range from the address (instrument number) to that before the checksum is converted to binary notation, and the total value is calculated.

The lower one byte of the total value is converted to 2's complement, and then to hexadecimal numbers, that is, ASCII code for the checksum.

- 1's complement: Reverse each binary bit. 0 will become 1 and vice versa.
- 2's complement: Add 1 to 1's complement.

Checksum Calculation Example

Data item 0008H (EVT ON delay time): 100 seconds (0064H)

Address (instrument number): 0 (20H)

[e.g.]

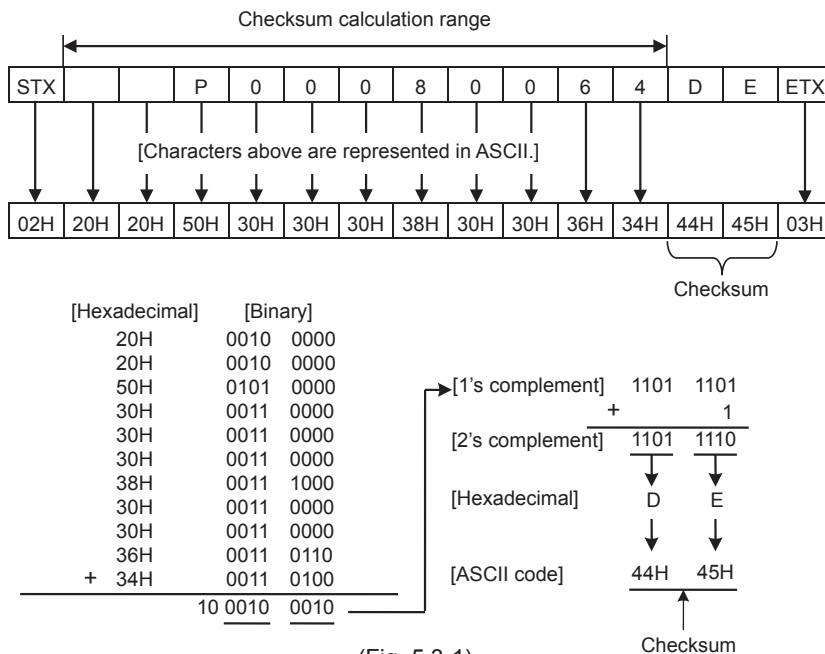

(Fig. 5.3-1)

6. MODBUS Protocol

6.1 Transmission Mode

There are 2 transmission modes (ASCII and RTU) in MODBUS protocol.

ASCII Mode

Hexadecimal (0 to 9, A to F), which is divided into high order (4-bit) and low order (4-bit) out of 8-bit binary data in command is transmitted as ASCII characters.

Data format Start bit: 1 bit
 Data bit: 7 bits (8 bits) (Selectable)
 Parity: Even (No parity, Odd) (Selectable)
 Stop bit: 1 bit (2 bits) (Selectable)

Error detection: LRC (Longitudinal Redundancy Check)

RTU Mode

8-bit binary data in command is transmitted as it is.

Data format Start bit: 1 bit
 Data bit: 8 bits
 Parity: No parity (Even, Odd) (Selectable)
 Stop bit: 1 bit (2 bits) (Selectable)

Error detection: CRC-16 (Cyclic Redundancy Check)

6.2 Data Communication Interval

ASCII Mode

Max.1 second of interval between characters

RTU Mode

Communication speed 9600 bps, 19200 bps:

To transmit continuously, an interval between characters which consist of one message, must be within 1.5-character transmission times.

Communication speed 38400 bps:

To transmit continuously, an interval between characters which consist of one message, must be within 750 μ s.

If an interval lasts longer than 1.5-character transmission times or 750 μ s, the AER-101-TU assumes that transmission from the master is finished, which results in a communication error, and will not return a response.

6.3 Message Configuration

ASCII Mode

ASCII mode message is configured to start by Header [: (colon) (3AH)] and end by Delimiter [CR (carriage return) (0DH) + LF (Line feed) (0AH)].

| | | | | | | |
|---------------|------------------|------------------|------|--------------------|-------------------|-------------------|
| Header (:) | Slave address | Function code | Data | Error check LRC | Delimiter (CR) | Delimiter (LF) |
|---------------|------------------|------------------|------|--------------------|-------------------|-------------------|

RTU Mode

Communication speed 9600 bps, 19200 bps: RTU mode is configured to start after idle time is processed for more than 3.5-character transmissions, and end after idle time is processed for more than 3.5-character transmissions.

Communication speed 38400 bps: RTU mode is configured to start after idle time is processed for more than 1.75 ms, and end after idle time is processed for more than 1.75 ms.

| | | | | | |
|------------------------|------------------|------------------|------|-----------------------|------------------------|
| 3.5 idle characters | Slave address | Function code | Data | Error check CRC-16 | 3.5 idle characters |
|------------------------|------------------|------------------|------|-----------------------|------------------------|

6.3.1 Slave Address

Slave address is an individual instrument number on the slave side, and is set within the range 0 to 95 (00H to 5FH).

The master identifies slaves by the slave address of the requested message.

The slave informs the master which slave is responding to the master by placing its own address in the response message.

Slave address 00H (Broadcast address) can identify all the slaves connected. However, slaves do not respond.

6.3.2 Function Code

The function code is the command code for the slave to undertake one of the following actions.

(Table 6.3.2-1)

| Function Code | Contents |
|---------------|---|
| 03 (03H) | Reading the set value and information from slaves |
| 06 (06H) | Setting to slaves |

The Function code is used to discern whether the response is normal (acknowledgement) or if any error (negative acknowledgement) has occurred when the slave returns the response message to the master.

When acknowledgement is returned, the slave simply returns the original function code.

When negative acknowledgement is returned, the MSB of the original function code is set as 1 for the response.

(For example, if the master sends request message setting 10H to the function code by mistake, slave returns 90H by setting the MSB to 1, because the former is an illegal function.)

For negative acknowledgement, the exception codes below are set to the data of the response message, and returned to the master in order to inform it of what kind of error has occurred. (Table 6.3.2-2)

(Table 6.3.2-2)

| Exception Code | Contents |
|----------------|---|
| 1 (01H) | Illegal function (Non-existent function) |
| 2 (02H) | Illegal data address (Non-existent data address) |
| 3 (03H) | Illegal data value (Value out of the setting range) |
| 17 (11H) | Shinko protocol error code 4 [Status unable to be set (During Turbidity/SS sensor calibration mode, or Zero/Span output signal adjustment mode)] |
| 18 (12H) | Shinko protocol error code 5 (During setting mode by keypad operation) |

6.3.3 Data

Data differs depending on the function code.

A request message from the master is composed of a data item, amount of data and setting data.

A response message from the slave is composed of the byte count, data and exception codes in negative acknowledgements.

The effective range of data is -32768 to 32767 (8000H to 7FFFH).

6.3.4 Error Check

ASCII Mode

After calculating LRC (Longitudinal Redundancy Check) from the slave address to the end of data, the calculated 8-bit data is converted to two ASCII characters, and are appended to the end of message.

How to calculate LRC

- ① Create a message in RTU mode.
- ② Add all the values from the slave address to the end of data. This is assumed as X.
- ③ Make a complement for X (bit reverse). This is assumed as X.
- ④ Add a value of 1 to X. This is assumed as X.
- ⑤ Set X as an LRC to the end of the message.
- ⑥ Convert the whole message to ASCII characters.

RTU Mode

After calculating CRC-16 (Cyclic Redundancy Check) from the slave address to the end of the data, the calculated 16-bit data is appended to the end of message in sequence from low order to high order.

How to calculate CRC-16

In the CRC-16 system, the information is divided by the polynomial series. The remainder is added to the end of the information and transmitted. The generation of a polynomial series is as follows.

(Generation of polynomial series: $X^{16} + X^{15} + X^2 + 1$)

- ① Initialize the CRC-16 data (assumed as X) (FFFFH).
- ② Calculate exclusive OR (XOR) with the 1st data and X. This is assumed as X.
- ③ Shift X one bit to the right. This is assumed as X.
- ④ When a carry is generated as a result of the shift, XOR is calculated by X of ③ and the fixed value (A001H). This is assumed as X. If a carry is not generated, go to step ⑤.
- ⑤ Repeat steps ③ and ④ until shifting 8 times.

- ⑥ XOR is calculated with the next data and X. This is assumed as X.
- ⑦ Repeat steps ③ to ⑤.
- ⑧ Repeat steps ③ to ⑤ up to the final data.
- ⑨ Set X as CRC-16 to the end of message in sequence from low order to high order.

6.4 Message Example

ASCII Mode

Numerals written below the command represent the number of characters.

① Reading [Slave address 1, Data item 0080H (Turbidity/SS input value)]

- A request message from the master

Amount of data means how many data items are to be read. It is fixed as (30H 30H 30H 31H).

| Header | Slave address | Function code | Data item | Amount of data | Error check LRC | Delimiter |
|--------|---------------|---------------|------------------------------|------------------------------|-----------------|-----------|
| (3AH) | (30H 31H) | (30H 33H) | [0080H] (30H 30H 38H 30H) | [0001H] (30H 30H 30H 31H) | (37H 42H) | (0DH 0AH) |
| 1 | 2 | 2 | 4 | 4 | 2 | 2 |

- Response message from the slave in normal status [When 10.0 (Formazin) (0064H)]

The response byte count means the byte count of data which have been read. It is fixed as (30H 32H).

| Header | Slave address | Function code | Response byte count | Data | Error check LRC | Delimiter |
|--------|---------------|---------------|---------------------|------------------------------|-----------------|-----------|
| (3AH) | (30H 31H) | (30H 33H) | [02H] (30H 32H) | [0064H] (30H 30H 36H 34H) | (39H 36H) | (0DH 0AH) |
| 1 | 2 | 2 | 2 | 4 | 2 | 2 |

- Response message from the slave in exception (error) status (When a data item is incorrect)

The function code MSB is set to 1 for the response message in exception (error) status. (83H is returned)
The exception code 02H (Non-existent data address) is returned (error).

| Header | Slave address | Function code | Exception code | Error check LRC | Delimiter |
|--------|---------------|---------------|--------------------|-----------------|-----------|
| (3AH) | (30H 31H) | (38H 33H) | [02H] (30H 32H) | (37H 41H) | (0DH 0AH) |
| 1 | 2 | 2 | 2 | 2 | 2 |

② Setting [Slave address 1, Data item 0008H (EVT ON delay time)]

- A request message from the master [When EVT ON delay time is set to 100 seconds (0064H)]

| Header | Slave address | Function code | Data item | Data | Error check LRC | Delimiter |
|--------|---------------|---------------|------------------------------|------------------------------|-----------------|-----------|
| (3AH) | (30H 31H) | (30H 36H) | [0008H] (30H 30H 30H 38H) | [0064H] (30H 30H 36H 34H) | (38H 44H) | (0DH 0AH) |
| 1 | 2 | 2 | 4 | 4 | 2 | 2 |

- Response message from the slave in normal status

| Header | Slave address | Function code | Data item | Data | Error check LRC | Delimiter |
|--------|---------------|---------------|------------------------------|------------------------------|-----------------|-----------|
| (3AH) | (30H 31H) | (30H 36H) | [0008H] (30H 30H 30H 38H) | [0064H] (30H 30H 36H 34H) | (38H 44H) | (0DH 0AH) |
| 1 | 2 | 2 | 4 | 4 | 2 | 2 |

- Response message from the slave in exception (error) status (When a value out of the setting range is set.)

The function code MSB is set to 1 for the response message in exception (error) status (86H is returned).
The exception code 03H (Value out of the setting range) is returned (error).

| Header | Slave address | Function code | Exception code | Error check LRC | Delimiter |
|--------|---------------|---------------|--------------------|-----------------|-----------|
| (3AH) | (30H 31H) | (38H 36H) | [03H] (30H 33H) | (37H 36H) | (0DH 0AH) |
| 1 | 2 | 2 | 2 | 2 | 2 |

RTU Mode

① Reading [Slave address 1, Data item 0080H (Turbidity/SS input value)]

- A request message from the master

Amount of data means how many data items are to be read. It is fixed as (0001H).

| | | | | | | |
|---------------------|---------------------|---------------------|-------------------|------------------------|----------------------------|---------------------|
| 3.5 idle characters | Slave address (01H) | Function code (03H) | Data item (0080H) | Amount of data (0001H) | Error check CRC-16 (85E2H) | 3.5 idle characters |
| | 1 | 1 | 2 | 2 | 2 | |

- Response message from the slave in normal status [When 10.0 (Formazin) (0064H)]

The response byte count means the byte count of data which has been read. It is fixed as (02H).

| | | | | | | |
|---------------------|---------------------|---------------------|---------------------------|--------------|----------------------------|---------------------|
| 3.5 idle characters | Slave address (01H) | Function code (03H) | Response byte count (02H) | Data (0064H) | Error check CRC-16 (B9AFH) | 3.5 idle characters |
| | 1 | 1 | 1 | 2 | 2 | |

- Response message from the slave in exception (error) status (When a data item is incorrect)

The function code MSB is set to 1 for the response message in exception (error) status (83H is returned.).

The exception code (02H: Non-existent data address) is returned (error).

| | | | | | |
|---------------------|---------------------|---------------------|----------------------|----------------------------|---------------------|
| 3.5 idle characters | Slave address (01H) | Function code (83H) | Exception code (02H) | Error check CRC-16 (C0F1H) | 3.5 idle characters |
| | 1 | 1 | 1 | 2 | |

② Setting [Slave address 1, Data item 0008H (EVT ON delay time)]

- A request message from the master [When EVT ON delay time is set to 100 seconds (0064H)]

| | | | | | | |
|---------------------|---------------------|---------------------|-------------------|--------------|----------------------------|---------------------|
| 3.5 idle characters | Slave address (01H) | Function code (06H) | Data item (0008H) | Data (0064H) | Error check CRC-16 (D9E3H) | 3.5 idle characters |
| | 1 | 1 | 2 | 2 | 2 | |

- Response message from the slave in normal status

| | | | | | | |
|---------------------|---------------------|---------------------|-------------------|--------------|----------------------------|---------------------|
| 3.5 idle characters | Slave address (01H) | Function code (06H) | Data item (0008H) | Data (0064H) | Error check CRC-16 (D9E3H) | 3.5 idle characters |
| | 1 | 1 | 2 | 2 | 2 | |

- Response message from the slave in exception (error) status (When a value out of the setting range is set)
The function code MSB is set to 1 for the response message in exception (error) status. (86H is returned.)

The exception code (03H: Value out of the setting range) is returned (error).

| | | | | | |
|---------------------|---------------------|---------------------|----------------------|----------------------------|---------------------|
| 3.5 idle characters | Slave address (01H) | Function code (86H) | Exception code (03H) | Error check CRC-16 (0261H) | 3.5 idle characters |
| | 1 | 1 | 1 | 2 | |

7. Communication Command Table

7.1 Note on Setting/Reading Command

- The data (set value, decimal) is converted to hexadecimal numbers.
A negative number is represented in 2's complement.
- When connecting multiple slaves, the address (instrument number) must not be duplicated.
- Data items 0200H to 0209H (User save area 1 to 10) can be read or set in 1 word units.
Effective range of data is -32768 to 32767 (8000H to 7FFFH).
- MODBUS protocol uses Holding Register addresses. The Holding Register addresses are created as follows. A Shinko command data item is converted to decimal number, and the offset of 40001 is added. The result is the Holding Register address.
Using Data item 0008H (EVT ON delay time) as an example: Data item in the sending message is 0008H, however, MODBUS protocol Holding Register address is 40009 (8 + 40001).
- Even if options are not ordered, setting or reading via software communication will be possible.

(1) Setting Command

- Up to 1,000,000 (one million) entries can be stored in non-volatile IC memory.
If the number of settings exceeds the limit, the data will not be saved. So, do not change the set values frequently via communication. (If a value set via software communication is the same as the value before the setting, the value will not be written in non-volatile IC memory.)
- Be sure to select Lock 3 when changing the set value frequently via software communication. If Lock 3 is selected, all set values – except Measurement range, Measurement unit, Span setting, Zero and Span output signals, Turbidity/SS sensor calibration, Transmission output Zero and Span adjustments – can be temporarily changed. However, they revert to their previous value after the power is turned off because they are not saved in the non-volatile IC memory.
Do not change the setting item 'EVT type'. If it is changed, it will affect other setting items.
- Setting range of each item is the same as that of keypad operation.
- When the data (set value) has a decimal point, a whole number (hexadecimal) without a decimal point is used.
- If EVT type is changed at Data item 0005H (EVT type), EVT value will default to "0".
EVT output status will also be initialized.
- Settings via software communication are possible while in Set value lock status.
- Communication parameters such as Instrument Number, Communication Speed of the slave cannot be set by software communication. They can only be set via the keypad. (p.3)
- When sending a command by Global address [95 (7FH), Shinko protocol] or Broadcast address [(00H), MODBUS protocol], the same command is sent to all the slaves connected. However, the response is not returned.

(2) Reading Command

- When the data (set value) has a decimal point, a whole number (hexadecimal) without a decimal point is used for a response.

7.2 Setting/Reading Command

| Shinko Command Type | MODBUS Function Code | Data Item | | Data | | | | | | | | | | | | | | | | | | |
|---------------------|--------------------------|--------------------------|---|--|------|-------------------|-------|-------|-------------------------|-------------------------|-------|---------------------|-------------------------|-------|----------------------|--------------------------|-------|-------------------------|-----------------------|-------|--------------------------|--------------------|
| 50H/20H | 06H/03H | 0004H | Measurement range | | | | | | | | | | | | | | | | | | | |
| | | | | | | | | | | | | | | | | | | | | | | |
| | | | | | | | | | | | | | | | | | | | | | | |
| | | | | | | | | | | | | | | | | | | | | | | |
| | | | | | | | | | | | | | | | | | | | | | | |
| | | | | | | | | | | | | | | | | | | | | | | |
| | | | | <table border="1"> <thead> <tr> <th>Data</th> <th>Measurement Range</th> <th>Model</th> </tr> </thead> <tbody> <tr> <td>0000H</td> <td>0.0 to 100.0 (Formazin)</td> <td>Turbidity sensor TC-100</td> </tr> <tr> <td>0001H</td> <td>0 to 500 (Formazin)</td> <td>Turbidity sensor TC-500</td> </tr> <tr> <td>0002H</td> <td>0 to 3000 (Formazin)</td> <td>Turbidity sensor TC-3000</td> </tr> <tr> <td>0003H</td> <td>0 to 1000 mg/L (Kaolin)</td> <td>SS sensor TCS-1000(E)</td> </tr> <tr> <td>0004H</td> <td>0 to 50000 mg/L (Kaolin)</td> <td>SS sensor TS-MxS-A</td> </tr> </tbody> </table> | Data | Measurement Range | Model | 0000H | 0.0 to 100.0 (Formazin) | Turbidity sensor TC-100 | 0001H | 0 to 500 (Formazin) | Turbidity sensor TC-500 | 0002H | 0 to 3000 (Formazin) | Turbidity sensor TC-3000 | 0003H | 0 to 1000 mg/L (Kaolin) | SS sensor TCS-1000(E) | 0004H | 0 to 50000 mg/L (Kaolin) | SS sensor TS-MxS-A |
| Data | Measurement Range | Model | | | | | | | | | | | | | | | | | | | | |
| 0000H | 0.0 to 100.0 (Formazin) | Turbidity sensor TC-100 | | | | | | | | | | | | | | | | | | | | |
| 0001H | 0 to 500 (Formazin) | Turbidity sensor TC-500 | | | | | | | | | | | | | | | | | | | | |
| 0002H | 0 to 3000 (Formazin) | Turbidity sensor TC-3000 | | | | | | | | | | | | | | | | | | | | |
| 0003H | 0 to 1000 mg/L (Kaolin) | SS sensor TCS-1000(E) | | | | | | | | | | | | | | | | | | | | |
| 0004H | 0 to 50000 mg/L (Kaolin) | SS sensor TS-MxS-A | | | | | | | | | | | | | | | | | | | | |
| 50H/20H | 06H/03H | 0005H | EVT type | 0000H: No action 0001H: Turbidity/SS input low limit action 0002H: Turbidity/SS input high limit action 0003H: Error output 0004H: Fail output 0005H: Turbidity/SS input High/Low limits independent action | | | | | | | | | | | | | | | | | | |
| 50H/20H | 06H/03H | 0006H | EVT value | Set value (Decimal point ignored.) | | | | | | | | | | | | | | | | | | |
| 50H/20H | 06H/03H | 0007H | EVT ON side | Set value (Decimal point ignored.) | | | | | | | | | | | | | | | | | | |
| 50H/20H | 06H/03H | 0008H | EVT ON delay time | Set value | | | | | | | | | | | | | | | | | | |
| 50H/20H | 06H/03H | 0009H | EVT OFF delay time | Set value | | | | | | | | | | | | | | | | | | |
| 50H/20H | 06H/03H | 000AH | Turbidity/SS input filter time constant | Set value (Decimal point ignored.) | | | | | | | | | | | | | | | | | | |
| 50H/20H | 06H/03H | 000CH | Turbidity/SS inputs for moving average | Set value | | | | | | | | | | | | | | | | | | |
| 50H/20H | 06H/03H | 000DH | Calibration wait time | Set value | | | | | | | | | | | | | | | | | | |
| 50H/20H | 06H/03H | 0010H | EVT proportional band | Set value (Decimal point ignored.) | | | | | | | | | | | | | | | | | | |
| 50H/20H | 06H/03H | 0011H | EVT reset | Set value (Decimal point ignored.) | | | | | | | | | | | | | | | | | | |
| 50H/20H | 06H/03H | 0012H | EVT proportional cycle | Set value | | | | | | | | | | | | | | | | | | |
| 50H/20H | 06H/03H | 0030H | Set value lock | 0000H: Unlock 0001H: Lock 1 0002H: Lock 2 0003H: Lock 3 | | | | | | | | | | | | | | | | | | |
| 50H/20H | 06H/03H | 0031H | Transmission output type | 0000H: Turbidity/SS transmission 0001H: EVT MV transmission | | | | | | | | | | | | | | | | | | |
| 50H/20H | 06H/03H | 0032H | Transmission output high limit | Set value (Decimal point ignored.) | | | | | | | | | | | | | | | | | | |
| 50H/20H | 06H/03H | 0033H | Transmission output low limit | Set value (Decimal point ignored.) | | | | | | | | | | | | | | | | | | |
| 50H/20H | 06H/03H | 0035H | Setting Display indication | 0000H: No indication 0001H: EVT value | | | | | | | | | | | | | | | | | | |
| 50H/20H | 06H/03H | 0037H | Backlight time | Set value | | | | | | | | | | | | | | | | | | |
| 50H | 06H | 0040H | Turbidity/SS sensor calibration mode | 0000H: Turbidity/SS Display Mode 0001H: Turbidity/SS sensor calibration mode | | | | | | | | | | | | | | | | | | |
| 50H | 06H | 0041H | Calibration signal output | 0001H: Calibration signal output | | | | | | | | | | | | | | | | | | |
| 50H | 06H | 0042H | Zero/Span output signal adjustment mode | 0000H: Turbidity/SS Display Mode 0001H: Zero output signal adjustment mode 0002H: Span output signal adjustment mode | | | | | | | | | | | | | | | | | | |
| 50H/20H | 06H/03H | 0043H | Zero output signal adjustment value | Set value (Decimal point ignored.) | | | | | | | | | | | | | | | | | | |

| Shinko Command Type | MODBUS Function Code | Data Item | | Data |
|---------------------|----------------------|-----------|---|--|
| 50H/20H | 06H/03H | 0044H | Span output signal adjustment value | Set value (Decimal point ignored.) |
| 50H/20H | 06H/03H | 0045H | EVT output when input errors occur | 0000H: Enabled 0001H: Disabled |
| 50H/20H | 06H/03H | 0048H | Output ON time when EVT output ON | Set value |
| 50H/20H | 06H/03H | 0049H | Output OFF time when EVT output ON | Set value |
| 50H/20H | 06H/03H | 0063H | Backlight selection | 0000H: All are backlit. 0001H: Turbidity/SS Display is backlit. 0002H: Setting Display is backlit. 0003H: Action indicator is backlit. 0004H: Turbidity/SS Display + Setting Display are backlit. 0005H: Turbidity/SS Display + Action indicator are backlit. 0006H: Setting Display + Action indicator are backlit. |
| 50H/20H | 06H/03H | 0064H | Turbidity/SS color | 0000H: Green 0001H: Red 0002H: Orange 0003H: Turbidity/SS color changes continuously. |
| 50H/20H | 06H/03H | 0065H | Turbidity/SS color range | Set value (Decimal point ignored.) |
| 50H/20H | 06H/03H | 0066H | Bar graph indication | 0000H: No indication 0001H: Transmission output |
| 50H/20H | 06H/03H | 0067H | Turbidity/SS color reference value | Set value (Decimal point ignored.) |
| 50H/20H | 06H/03H | 0068H | Turbidity/SS input sensor correction | Set value (Decimal point ignored.) |
| 50H/20H | 06H/03H | 0070H | EVT output high limit | Set value |
| 50H/20H | 06H/03H | 0071H | EVT output low limit | Set value |
| 50H | 06H | 007FH | Key operation change flag clearing | 0001H: Clear change flag. |
| 50H/20H | 06H/03H | 0100H | EVT hysteresis type | 0000H: Medium Value 0001H: Reference Value |
| 50H/20H | 06H/03H | 0104H | EVT OFF side | Set value (Decimal point ignored.) |
| 50H/20H | 06H/03H | 0108H | Measurement unit | 0000H: Formazin 0001H: Kaolin (mg/L) |
| 50H/20H | 06H/03H | 0109H | Span setting | Set value (Decimal point ignored.) |
| 50H/20H | 06H/03H | 010FH | Transmission output status when calibrating | 0000H: Last value HOLD 0001H: Set value HOLD 0002H: Measured value |
| 50H/20H | 06H/03H | 0110H | Transmission output value HOLD when calibrating | Set value (Decimal point ignored.) |

| Shinko Command Type | MODBUS Function Code | Data Item | | Data |
|---------------------|----------------------|-----------|---|--|
| 50H/20H | 06H/03H | 0111H | Transmission output status when adjusting output signal | 0000H: Last value HOLD 0001H: Set value HOLD 0002H: Measured value |
| 50H/20H | 06H/03H | 0112H | Transmission output value HOLD when adjusting output signal | Set value (Decimal point ignored.) |
| 50H | 06H | 0126H | Transmission output adjustment mode | 0000H: Turbidity/SS Display Mode 0001H: Transmission output Zero adjustment mode 0002H: Transmission output Span adjustment mode |
| 50H/20H | 06H/03H | 0127H | Transmission output Zero adjustment value | Set value (Decimal point ignored.) |
| 50H/20H | 06H/03H | 0128H | Transmission output Span adjustment value | Set value (Decimal point ignored.) |
| 50H/20H | 06H/03H | 0139H | EVT High/Low limits independent lower side value | Set value (Decimal point ignored.) |
| 50H/20H | 06H/03H | 013DH | EVT High/Low limits independent upper side value | Set value (Decimal point ignored.) |
| 50H/20H | 06H/03H | 0141H | EVT hysteresis | Set value (Decimal point ignored.) |
| 50H/20H | 06H/03H | 0200H | User save area 1 | -32768 to 32767 (8000H to 7FFFH) |
| 50H/20H | 06H/03H | 0201H | User save area 2 | -32768 to 32767 (8000H to 7FFFH) |
| 50H/20H | 06H/03H | 0202H | User save area 3 | -32768 to 32767 (8000H to 7FFFH) |
| 50H/20H | 06H/03H | 0203H | User save area 4 | -32768 to 32767 (8000H to 7FFFH) |
| 50H/20H | 06H/03H | 0204H | User save area 5 | -32768 to 32767 (8000H to 7FFFH) |
| 50H/20H | 06H/03H | 0205H | User save area 6 | -32768 to 32767 (8000H to 7FFFH) |
| 50H/20H | 06H/03H | 0206H | User save area 7 | -32768 to 32767 (8000H to 7FFFH) |
| 50H/20H | 06H/03H | 0207H | User save area 8 | -32768 to 32767 (8000H to 7FFFH) |
| 50H/20H | 06H/03H | 0208H | User save area 9 | -32768 to 32767 (8000H to 7FFFH) |
| 50H/20H | 06H/03H | 0209H | User save area 10 | -32768 to 32767 (8000H to 7FFFH) |

7.3 Read Only Command

| Shinko Command Type | MODBUS Function Code | Data Item | Data | | | | | | | | | | | | |
|---------------------|----------------------|------------------------------------|--|----------|----------|--------|---|---|---------------------------|---|---|------------------------------------|---|---|------------------------------------|
| 20H | 03H | 0080H | Turbidity/SS input value Turbidity/SS input value (Decimal point ignored.) | | | | | | | | | | | | |
| 20H | 03H | 0081H | <p>Status flag 1 0000 0000 0000 0000 2^{15} to 2^0 2^0 digit: Not used (Always 0) 2^1 digit: When Turbidity/SS input value has exceeded the value equivalent to 20.5 mA DC. 0: Normal 1: Error 2^2 digit: When Turbidity/SS input value has dropped below the value equivalent to 3.5 mA DC. 0: Normal 1: Error 2^3 digit: When Analog signal (+, White) (-, Black) cable of Turbidity/SS sensor is disconnected or short-circuited. 0: Normal 1: Error 2^4 digit: When receiving Self-check output from Turbidity/SS sensor 0: Normal 1: Error 2^5 digit: Not used (Always 0) 2^6 digit: EVT output flag 0: OFF 1: ON 2^7 digit: Self-check output flag 0: OFF 1: ON 2^8 to 2^9 digits: Not used (Always 0) 2^{10} digit: Unit status flag 0: Turbidity/SS Display Mode 1: Setting mode 2^{11} digit: Turbidity/SS sensor calibration status flag 0: Turbidity/SS Display Mode 1: Turbidity/SS sensor calibration mode 2^{12}, 2^{13} digits: Zero/Span output signal adjustment status flag</p> <table border="1"> <thead> <tr> <th>2^{13}</th> <th>2^{12}</th> <th>Status</th> </tr> </thead> <tbody> <tr> <td>0</td> <td>0</td> <td>Turbidity/SS Display Mode</td> </tr> <tr> <td>0</td> <td>1</td> <td>Zero output signal adjustment mode</td> </tr> <tr> <td>1</td> <td>0</td> <td>Span output signal adjustment mode</td> </tr> </tbody> </table> <p>2^{14} digit: EVT output 0: OFF 1: ON 2^{15} digit: Change in key operation 0: No 1: Yes</p> | 2^{13} | 2^{12} | Status | 0 | 0 | Turbidity/SS Display Mode | 0 | 1 | Zero output signal adjustment mode | 1 | 0 | Span output signal adjustment mode |
| 2^{13} | 2^{12} | Status | | | | | | | | | | | | | |
| 0 | 0 | Turbidity/SS Display Mode | | | | | | | | | | | | | |
| 0 | 1 | Zero output signal adjustment mode | | | | | | | | | | | | | |
| 1 | 0 | Span output signal adjustment mode | | | | | | | | | | | | | |

| Shinko Command Type | MODBUS Function Code | Data Item | Data | | | | | | | | | | | | |
|---------------------|----------------------|---|--|-------|-------|--------|---|---|---------------------------|---|---|---|---|---|---|
| 20H | 03H | 0091H | <p>Status flag 2 0000 0000 0000 0000 2^{15} to 2^0</p> <p>2^0 digit: During Span output signal adjustment, if Turbidity/SS input value has exceeded the value equivalent to 20.5 mA DC. 0: Normal 1: Error</p> <p>2^1 digit: During Zero output signal adjustment, if Turbidity/SS input value has dropped below the value equivalent to 3.5 mA DC. 0: Normal 1: Error</p> <p>2^2 digit: During calibration, if the output signal from Turbidity/SS sensor has not reached 2 mA DC. 0: Normal 1: Error</p> <p>2^3 digit: After calibration is complete, if the output signal from the Turbidity/SS sensor has not returned to 4 mA DC. 0: Normal 1: Error</p> <p>2^4 digit: Turbidity/SS sensor calibration end status flag 0: During Turbidity/SS sensor calibration or Turbidity/SS Display Mode 1: Turbidity/SS sensor calibration is complete</p> <p>$2^5, 2^6$ digits: Transmission output adjustment status flag</p> <table border="1"> <thead> <tr> <th>2^6</th> <th>2^5</th> <th>Status</th> </tr> </thead> <tbody> <tr> <td>0</td> <td>0</td> <td>Turbidity/SS Display Mode</td> </tr> <tr> <td>0</td> <td>1</td> <td>During Transmission output Zero adjustment in Transmission output adjustment mode</td> </tr> <tr> <td>1</td> <td>0</td> <td>During Transmission output Span adjustment in Transmission output adjustment mode</td> </tr> </tbody> </table> <p>2^7 to 2^{15} digits: Not used (Always 0)</p> | 2^6 | 2^5 | Status | 0 | 0 | Turbidity/SS Display Mode | 0 | 1 | During Transmission output Zero adjustment in Transmission output adjustment mode | 1 | 0 | During Transmission output Span adjustment in Transmission output adjustment mode |
| 2^6 | 2^5 | Status | | | | | | | | | | | | | |
| 0 | 0 | Turbidity/SS Display Mode | | | | | | | | | | | | | |
| 0 | 1 | During Transmission output Zero adjustment in Transmission output adjustment mode | | | | | | | | | | | | | |
| 1 | 0 | During Transmission output Span adjustment in Transmission output adjustment mode | | | | | | | | | | | | | |

7.4 Calibration via Communication Command

Turbidity/SS Sensor Calibration mode, Zero and Span output signal adjustment modes, Transmission Output Adjustment mode are described below.

7.4.1 Turbidity/SS Sensor Calibration Mode

The following outlines the procedure for Turbidity/SS Sensor calibration.

| Step | Operation |
|------|--|
| ① | Clean the body of Turbidity/SS sensor, particularly its lens(es). |
| ② | Immerse the Turbidity/SS sensor in the distilled water or ion-exchanged water. |
| ③ | Set Data item 0040H (Turbidity/SS sensor calibration mode) to 0001H (Turbidity/SS sensor calibration mode). The unit will proceed to Turbidity/SS Sensor calibration mode. (*) During the time set in [Calibration wait time], if 2 ¹¹ digit (Turbidity/SS sensor calibration status flag) is read at Data item 0081H (Status flag 1), 1 (Turbidity/SS sensor calibration mode) will be returned. Adjust the Turbidity/SS sensor to the ambient water temperature during the time set in [Calibration wait time]. |
| ④ | After the time set in [Calibration wait time] has elapsed, calibration automatically starts. During calibration, calibration signal output is turned ON for 3 seconds. When the calibration signal output switches from OFF to ON, the Turbidity/SS sensor will output approx. 2 mA DC of analog signal. |
| ⑤ | After the calibration is complete, the calibration signal output is turned OFF. If 2 ⁴ digit (Turbidity/SS sensor calibration end status flag) is read at Data item 0091H (Status flag 2), 1 (Turbidity/SS sensor calibration is complete) will be returned. When the calibration signal output switches from ON to OFF, the Turbidity/SS sensor returns to 4 mA DC of analog signal. |
| ⑥ | Set Data item 0040H (Turbidity/SS sensor calibration mode) to 0000H (Turbidity/SS Display Mode). The unit will return to Turbidity/SS Display Mode. If 2 ⁴ digit (Turbidity/SS sensor calibration end status flag) is read at Data item 0091H (Status flag 2), 0 (During Turbidity/SS sensor calibration or Turbidity/SS Display Mode) will be returned. If 2 ¹¹ digit (Turbidity/SS sensor calibration status flag) is read at Data item 0081H (Status flag 1), 0 (Turbidity/SS Display Mode) will be returned. |

(*) If Calibration wait time is set to 0 (zero) minutes, adjust the Turbidity/SS sensor to the ambient water temperature for approx. 5 minutes, then set Data item 0040H (Turbidity/SS Sensor calibration mode) to 0001H (Turbidity/SS sensor calibration mode).

After the unit enters Turbidity/SS Sensor calibration mode, set Data item 0041H (Calibration signal output) to 0001H (Calibration signal output), then refer to Step ④ and all following steps.

Error Codes when Calibrating Turbidity/SS Sensor

- During calibration, if the output signal from the Turbidity/SS sensor does not reach approx. 2 mA DC (*), and if 2² digit (During calibration, if the output signal from Turbidity/SS sensor has not reached 2 mA DC.) is read at Data item 0091H (Status flag 2), 1 (Error) will be returned.

(*) Before the calibration signal output switches from ON to OFF, and if the output signal from the Turbidity/SS sensor is between 1 and 3 mA DC, it is regarded as normal. If the output signal is outside of this range, it is regarded as an error.

- After calibration is completed, if the output signal from the Turbidity/SS sensor does not return to 4 mA DC (*), and if 2³ digit (After calibration is complete, if the output signal from the Turbidity/SS sensor has not returned to 4 mA DC.) is read at Data item 0091H (Status flag 2), 1 (Error) will be returned.

(*) Approximately 5 seconds after the calibration signal output switches from ON to OFF, and if the output signal from the Turbidity/SS sensor is between 3.5 and 4.5 mA DC, it is regarded as normal. If the output signal is outside of this range, it is regarded as an error.

To release the error code, set Data item 0040H (Turbidity/SS sensor calibration mode) to 0000H (Turbidity/SS Display Mode).

The unit returns to Turbidity/SS Display Mode.

Error codes in Turbidity/SS Display Mode are shown below.

- In Turbidity/SS Display Mode, if Data item 0041H (Calibration signal output) is set to 0001H (Calibration signal output), Shinko Error code 4 (34H, Shinko protocol) or MODBUS Exception code 17 (11H, MODBUS protocol) will be returned.
- If 0001H (Lock 1), 0002H (Lock 2) or 0003H (Lock 3) is selected at Data item 0030H (Set value lock), and if Data item 0040H (Turbidity/SS Sensor calibration mode) is set to 0001H (Turbidity/SS sensor calibration mode), or if Data item 0041H (Calibration signal output) is set to 0001H (Calibration signal output), Shinko Error code 4 (34H, Shinko protocol) or MODBUS Exception code 17 (11H, MODBUS protocol) will be returned.

7.4.2 Zero and Span Output Signal Adjustments



Caution

- Be sure to perform turbidity/SS sensor calibration before adjusting Zero and Span output signals.
- Be sure to adjust Span output signal after Zero output signal is adjusted.

Adjust Zero and Span output signals following the procedure below.

| Step | Operation |
|------|--|
| ① | Clean the body of Turbidity/SS sensor, particularly its lens(es). |
| ② | Immerse the Turbidity/SS sensor in the distilled water or ion-exchanged water. |
| ③ | Set Data item 0042H (Zero/Span output signal adjustment mode) to 0001H (Zero output signal adjustment mode). The unit will proceed to Zero output signal adjustment mode. During Zero output signal adjustment, if 2^{13} , 2^{12} digits (Zero/Span output signal adjustment status flag) are read at Data item 0081H, [01: Zero output signal adjustment mode] will be returned. |
| ④ | After the Turbidity/SS sensor has adjusted to the ambient water temperature for approx. 5 minutes, check Turbidity/SS input value at Data item 0080H (Turbidity/SS input value). |
| ⑤ | If Turbidity/SS input value is not 0 (zero), set the Zero output signal adjustment value at Data item 0043H (Zero output signal adjustment value). Setting range of Zero output signal adjustment value: $\pm 5\%$ of measurement span |
| ⑥ | Check Turbidity/SS input value at Data item 0080H (Turbidity/SS input value) again. If Turbidity/SS input value is not 0 (zero), return to Step ⑤. If Turbidity/SS input value is 0 (zero), the Zero output signal adjustment will be completed. |
| ⑦ | Set Data item 0042H (Zero/Span output signal adjustment mode) to 0002H (Span output signal adjustment mode). The unit will proceed to Span output signal adjustment mode. During Span output signal adjustment, if 2^{13} , 2^{12} digits (Zero/Span output signal adjustment status flag) are read at Data item 0081H, [10: Span output signal adjustment mode] will be returned. |
| ⑧ | Block the light beam between the lenses of the sensor for more than 30 seconds. [Be careful not to touch the lens(es).] Check Turbidity/SS input value at Data item 0080H (Turbidity/SS input value). |
| ⑨ | If Turbidity/SS input value is not the Measurement range high limit value, set the Span output signal adjustment value at Data item 0044H (Span output signal adjustment value). Setting range of Span output signal adjustment value: $\pm 5\%$ of measurement span |
| ⑩ | Check Turbidity/SS input value at Data item 0080H (Turbidity/SS input value) again. If Turbidity/SS input value is not the Measurement range high limit value, return to Step ⑨. If Turbidity/SS input value is the Measurement range high limit value, Span output signal adjustment will be completed. |

| | |
|---|--|
| ⑪ | <p>Set Data item 0042H (Zero/Span output signal adjustment mode) to 0000H (Turbidity/SS Display mode).</p> <p>The unit will return to Turbidity/SS Display Mode.</p> <p>If 2¹³, 2¹² digits (Zero/Span output signal adjustment status flag) are read at Data item 0081H (Status flag 1), [00: Turbidity/SS Display Mode] will be returned.</p> |
|---|--|

Error codes during Zero and Span output signal adjustments are shown below.

- During Zero output signal adjustment, when turbidity/SS input value has dropped below the value equivalent to 3.5 mA DC, and if 2¹ digit (During Zero output signal adjustment, if Turbidity/SS input value has dropped below the value equivalent to 3.5 mA DC.) is read at Data item 0091H (Status flag 2), 1 (Error) will be returned.
To release the error code, set Data item 0042H (Zero/Span output signal adjustment mode) to 0000H (Turbidity/SS Display Mode) or 0002H (Span output signal adjustment mode).
The unit will return to Turbidity/SS Display Mode.
- During Span output signal adjustment, when turbidity/SS input value has exceeded the value equivalent to 20.5 mA DC, and if 2⁰ digit (During Span output signal adjustment, if Turbidity/SS input value has exceeded the value equivalent to 20.5 mA DC.) is read at Data item 0091H (Status flag 2), 1 (Error) will be returned.
To release the error code, set Data item 0042H (Zero/Span output signal adjustment mode) to 0000H (Turbidity/SS Display Mode).
The unit will return to Turbidity/SS Display Mode.

Error codes in Turbidity/SS Display Mode are shown below.

- In Turbidity/SS Display Mode, if Zero or Span output signal adjustment value is set at Data items 0043H (Zero output signal adjustment value) or 0044H (Span output signal adjustment value), Shinko Error code 4 (34H, Shinko protocol) or MODBUS Exception code 17 (11H, MODBUS protocol) will be returned.
- If 0001H (Lock 1), 0002H (Lock 2) or 0003H (Lock 3) is selected at Data item 0030H (Set value lock), and if Zero or Span output signal adjustment value is set at Data item 0043H (Zero output signal adjustment value) or 0044H (Span output signal adjustment value), Shinko Error code 4 (34H, Shinko protocol) or MODBUS Exception code 17 (11H, MODBUS protocol) will be returned.

7.4.3 Transmission Output Adjustment

Fine adjustment of Transmission output is performed.

The AER-101-TU is adjusted at the factory, however, differences may occur between the indication value of the connected equipment (recorders, etc.) and output value of this instrument.

In this case, perform Transmission output Zero adjustment and Span adjustment.

| Step | Operation |
|------|---|
| ① | <p>Set Data item 0126H (Transmission output adjustment mode) to 0001H (Transmission output Zero adjustment mode).</p> <p>The unit will proceed to Transmission output Zero Adjustment mode.</p> <p>If 2⁶, 2⁵ digits (Transmission output adjustment status flag) are read at Data item 0091H (Status flag 2), [01: During Transmission output Zero adjustment in Transmission output adjustment mode] will be returned.</p> |
| ② | <p>Set the Transmission output Zero adjustment value at Data item 0127H (Transmission output Zero adjustment value), while checking the value indicated on the connected equipment (recorders, etc.)</p> <p>Setting range: $\pm 5.00\%$ of Transmission output span</p> |
| ③ | <p>Set Data item 0126H (Transmission output adjustment mode) to 0002H (Transmission output Span adjustment mode).</p> <p>The unit will proceed to Transmission output Span Adjustment mode.</p> <p>If 2⁶, 2⁵ digits (Transmission output adjustment status flag) are read at Data item 0091H (Status flag 2), [10: During Transmission output Span adjustment in Transmission output adjustment mode] will be returned.</p> |
| ④ | <p>Set the Transmission output Span adjustment value at Data item 0128H (Transmission output Span adjustment value), while checking the value indicated on the connected equipment (recorders, etc.)</p> <p>Setting range: $\pm 5.00\%$ of Transmission output span</p> |
| ⑤ | <p>Repeat steps ① to ④ if necessary.</p> |
| ⑥ | <p>To finish Transmission output adjustment, set Data item 0126H (Transmission output adjustment mode) to 0000H (Turbidity/SS Display Mode).</p> <p>The unit reverts to the Turbidity/SS Display Mode.</p> |

7.5 Notes on Programming Monitoring Software

(1) How to speed up the scan time

When monitoring multiple units of AER-101-TU, set the program so that the requisite minimum pieces of data such as Data item 0080H (Turbidity/SS input value), Data item 0081H (Status flag 1), Data item 0091H (Status flag 2), can be read. For other data, set the program so that they can be read only when their set value has been changed. This will speed up the scan time.

(2) How to read the set value changes made by the front keypad operation

If any set value is changed by keypad operation, the AER-101-TU will set [0081H (Status flag 1) 2¹⁵: Change in key operation] to 1 (Yes).

There are 2 methods of reading the set value changes made by the front keypad.

Reading method 1

- ① On the monitoring software side, check that [0081H (Status flag 1) 2¹⁵: Change in key operation] has been set to 1 (Yes), then read all set values.
- ② Clear [0081H (Status flag 1) 2¹⁵: Change in key operation], by setting Data item 007FH (Key operation change flag clearing) to 0001H (Clear change flag).
If 007FH (Key operation change flag clearing) is set to 0001H (Clear change flag) during the setting mode of the instrument, Error code 5 (35H, Shinko protocol) or Exception Code 18 (12H, MODBUS protocol) will be returned as a negative acknowledgement. And [0081H (Status flag 1) 2¹⁵: Change in key operation] cannot be cleared.
Set a program so that all set values can be read when a negative acknowledgement is returned.
- ③ Read all set values again after acknowledgement is returned.

Reading method 2

- ① On the monitoring software side, check that [0081H (Status flag 1) 2¹⁵: Change in key operation] has been set to 1 (Yes), then set 007FH (Key operation change flag clearing) to 0001H (Clear change flag).
- ② Set the program depending on the acknowledgement or negative acknowledgement as follows.
When acknowledgement is returned:
Consider it as settings completed, and read all set values.

When Error code 5 (35H, Shinko protocol) or Exception code 18 (12H, MODBUS protocol) is returned as a negative acknowledgement:
Consider it as still in setting mode, and read the requisite minimum pieces of data such as 0080H (Turbidity/SS input value), 0081H (Status flag 1), 0091H (Status flag 2), then return to step ①.

Thus, programs which do not affect the scan time can be created using the methods described above, even if set values on the monitoring software will not be updated until settings are complete.

(3) Note when sending all set values at one time

- When changing EVT type at Data item 0005H (EVT type), EVT value will default to 0 (zero).
First, send the EVT type, then send the EVT value at Data item 0006H (EVT value).

8. Specifications

| | | | | |
|------------------------|---|------------------------|--|--|
| Serial communication | The following operations can be carried out from an external computer. (1) Reading and setting of various set values (2) Reading of the Turbidity/SS input value and status (3) Function change, adjustment (4) Reading and setting of user save area | | | |
| Cable length | 1.2 km (Max.), Cable resistance: Within 50 Ω (Terminators are not necessary, but if used, use 120 Ω minimum on one side.) | | | |
| Communication line | EIA RS-485 | | | |
| Communication method | Half-duplex communication | | | |
| Communication speed | 9600, 19200, 38400 bps (Selectable by keypad) | | | |
| Synchronization | Start-stop synchronization | | | |
| Code form | ASCII, Binary | | | |
| Communication protocol | Shinko protocol, MODBUS ASCII, MODBUS RTU (Selectable by keypad) | | | |
| Data bit/Parity | 8-bits/No parity, 7-bits/No parity, 8-bits/Even, 7-bits/Even, 8-bits/Odd, 7-bits/Odd (Selectable by keypad) | | | |
| Stop bit | 1 bit, 2 bits (Selectable by keypad) | | | |
| Error correction | Command request repeat system | | | |
| Error detection | Parity check Checksum (Shinko protocol) LRC (MODBUS protocol ASCII) CRC-16 (MODBUS protocol RTU) | | | |
| Data format | Communication Protocol | Shinko Protocol | MODBUS ASCII | MODBUS RTU |
| | Start bit | 1 | 1 | 1 |
| | Data bit | 7 | 7 (8) Selectable | 8 |
| | Parity | Even | Even (No parity, Odd) Selectable | No parity (Even, Odd) Selectable |
| | Stop bit | 1 | 1 (2) Selectable | 1 (2) Selectable |

9. Troubleshooting

Check that power is being supplied to the master and slave that customers use. If communication failure still occurs, check the following.

| Problem | Possible Cause | Solution |
|--|--|--|
| Communication failure | Communication cable is not securely connected, or is disconnected/defective. | Check the communication cable and connector. |
| | Incorrect wiring of the communication cable and/or connector | Check the communication cable and connector. |
| | Imperfect contact between the communication cable and the connector, or between the communication connector and instrument port | Check the communication cable and connector. |
| | Communication speed of the slave does not match that of the master. | Check the communication speed of the slave and master. |
| | The data bit, parity and stop bit of the master do not correspond to those of the slave. | Check the data bit, parity and stop bit of the master and the slave. |
| | The instrument number (address) of the slave does not correspond to that of the command. | Check the instrument number (address) of the slave and command. |
| | The instrument numbers (addresses) are duplicated in multiple slaves. | Check the instrument numbers (addresses) of the slave. |
| | Make sure that the program is appropriate for the transmission timing. | Check the program. |
| Although communication is occurring, the response is a negative acknowledgement. | A non-existent command code has been sent. | Check the command code. |
| | The setting command data exceeds the setting range of the slave. | Check the setting range of the slave. |
| | The AER-101-TU cannot be set during calibration or adjustment mode (during Turbidity/SS sensor calibration mode, Zero/Span output signal adjustment mode). | Check the slave status. |
| | The AER-101-TU is in front keypad operation setting mode. | Return the unit to Turbidity/SS Display Mode. |

For all other malfunctions, please contact our main office or dealers.

SHINKO TECHNOS CO., LTD.
OVERSEAS DIVISION

Head Office : 2-5-1, Senbahigashi, Minoo, Osaka, Japan

URL: <http://www.shinko-technos.co.jp/e/>

E-mail: overseas@shinko-technos.co.jp

Tel : +81-72-727-6100

Fax: +81-72-727-7006