

DIN RAIL MOUNTED INDICATING CONTROLLER

DCL-33A

INSTRUCTION MANUAL

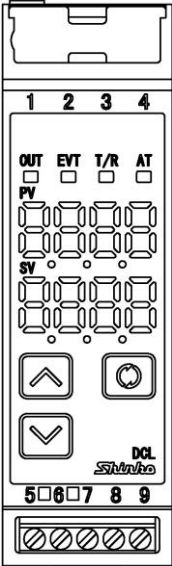

Shinko

Preface

Thank you for purchasing our DIN Rail Mounted Indicating Controller DCL-33A. This manual contains instructions for the mounting, functions, operations and notes when operating the DCL-33A. To ensure safe and correct use, thoroughly read and understand this manual before using this controller. To prevent accidents arising from the misuse of this controller, please ensure the operator receives this manual.

Notes

- This instrument should be used in accordance with the specifications described in the manual. If it is not used according to the specifications, it may malfunction or cause a fire.
- Be sure to follow the warnings, cautions and notices. If they are not observed, serious injury or malfunction may occur.
- The contents of this instruction manual are subject to change without notice.
- Care has been taken to ensure that the contents of this instruction manual are correct, but if there are any doubts, mistakes or questions, please inform our sales department.
- This instrument is designed to be installed on a DIN rail within a control panel indoors. If it is not, measures must be taken to ensure that the operator cannot touch power terminals or other high voltage sections.
- Any unauthorized transfer or copying of this document, in part or in whole, is prohibited.
- Shinko Technos Co., Ltd. is not liable for any damage or secondary damage(s) incurred as a result of using this product, including any indirect damage.

Safety Precautions (Be sure to read these precautions before using our products.)

The safety precautions are classified into categories: "Warning" and "Caution". Depending on circumstances, procedures indicated by Caution may result in serious consequences, so be sure to follow the directions for usage.

Warning Procedures which may lead to dangerous conditions and cause death or serious injury, if not carried out properly.

Caution Procedures which may lead to dangerous conditions and cause superficial to medium injury or physical damage or may degrade or damage the product, if not carried out properly.

Warning

- To prevent an electrical shock or fire, only Shinko or other qualified service personnel may handle the inner assembly.
- To prevent an electrical shock, fire or damage to the instrument, parts replacement may only be undertaken by Shinko or other qualified service personnel.

SAFETY PRECAUTIONS

- To ensure safe and correct use, thoroughly read and understand this manual before using this instrument.
- This instrument is intended to be used for industrial machinery, machine tools and measuring equipment.. Verify correct usage after purpose-of-use consultation with our agency or main office. (Never use this instrument for medical purposes with which human lives are involved.)
- External protection devices such as protective equipment against excessive temperature rise, etc. must be installed, as malfunction of this product could result in serious damage to the system or injury to personnel. Proper periodic maintenance is also required.
- This instrument must be used under the conditions and environment described in this manual. Shinko Technos Co., Ltd. does not accept liability for any injury, loss of life or damage occurring due to the instrument being used under conditions not otherwise stated in this manual.

Warning on Model Label

Caution

Failure to handle this instrument properly may result in minor or moderate injury or property damage due to fire, malfunction, malfunction, or electric shock. Please read this manual before using the product to ensure that you fully understand the product.

Caution with Respect to Export Trade Control Ordinance

To avoid this instrument from being used as a component in, or as being utilized in the manufacture of weapons of mass destruction (i.e. military applications, military equipment, etc.), please investigate the end users and the final use of this instrument. In the case of resale, ensure that this instrument is not illegally exported.

1. Installation Precautions

Caution

This instrument is intended to be used under the following environmental conditions (IEC61010-1): Overvoltage category , Pollution degree 2

Ensure the mounting location corresponds to the following conditions:

- A minimum of dust, and an absence of corrosive gases
- No flammable, explosive gases
- No mechanical vibrations or shocks
- No exposure to direct sunlight, an ambient temperature of 0 to 50 (32 to 122) that does not change rapidly, and no icing
- An ambient non-condensing humidity of 35 to 85 %RH
- No large capacity electromagnetic switches or cables through which large current is flowing.
- No water, oil, chemicals or the vapors of these substances can come into direct contact with the unit.
- Please note that the ambient temperature of this unit – not the ambient temperature of the control panel – must not exceed 50 (122) if mounted within a control panel, otherwise the life of electronic components (especially electrolytic capacitors) may be shortened.

Note: Avoid setting this instrument directly on or near flammable material even though the case of this instrument is made of flame-resistant resin.

2. Wiring Precautions

Caution

- Do not leave wire remnants in the instrument, because they could cause a fire or malfunction.
- Use correct fitting ferrules with an insulation sleeve for the terminal screw when wiring the DCL-33A.
- Tighten the terminal screw using the specified torque. If excessive force is applied to the screw when tightening, the terminal screw or case may be damaged.
- Do not apply a commercial power source to the sensor which is connected to the input terminal nor allow the power source to come into contact with the sensor.
- This instrument does not have a power switch, circuit breaker and fuse. Therefore it is necessary to install a power switch, circuit breaker and fuse externally near the controller.
(Recommended fuse: Time-lag fuse, rated voltage 250 V AC, rated current 2 A)
- For a 24 V AC/DC power source, do not confuse polarity when using direct current (DC).

3. Operation and Maintenance Precautions

Caution

- It is recommended that auto-tuning be performed during the trial run.
- Do not touch live terminals. This may cause an electric shock or problems in operation.
- Turn the power supply to the instrument OFF before retightening the terminal or cleaning.
Working on or touching the terminal with the power switched ON may result in severe injury or death due to electrical shock.
- Use a soft, dry cloth when cleaning the instrument.
(Alcohol based substances may tarnish or deface the unit.)
- As the display section is vulnerable, be careful not to put pressure on, scratch or strike it with a hard object.

4. Compliance with Safety Standards

Caution

- Always install the recommended fuse described in this manual externally.
- If the instrument is used in a manner not specified by the manufacturer, the protection provided by the instrument may be impaired.
- Use a device with reinforced insulation or double insulation for the external circuit connected to this product.
- When using this product as a UL certified product, use a power supply conforming to Class 2 or LIM for the external circuit connected to the product.

Characters used in this manual

Indication														
Number, /	-1	0	1	2	3	4	5	6	7	8	9			
Indication														
Alphabet	A	B	C	D	E	F	G	H	I	J	K	L	M	
Indication														
Alphabet	N	O	P	Q	R	S	T	U	V	W	X	Y	Z	

Contents

1. Model.....	6
1.1 Model.....	6
1.2 How to Read the Model Label.....	6
2. Names and Functions of Controller.....	7
3. Mounting to the Control Panel.....	8
3.1 Site Selection.....	8
3.2 External Dimensions (Scale: mm).....	8
3.3 CT (Current transformer) External Dimensions (Scale: mm).....	8
3.4 Mounting to and Removal from the DIN Rail.....	9
4. Wiring.....	10
4.1 Terminal Arrangement.....	11
4.2 Heater Burnout Alarm Output (W option).....	11
5. Setup.....	12
5.1 Main Setting Mode.....	13
5.2 Sub Setting Mode.....	13
5.3 Auxiliary Function Setting Mode 1.....	15
5.4 Auxiliary Function Setting Mode 2.....	16
5.5 Auxiliary Function Setting Mode 3.....	20
5.6 Output MV (manipulated variable) Indication.....	27
6. Simplified Converter Function.....	28
6.1 Fine Adjustment of Converter Output (4 to 20 mA DC).....	29
6.2 Converter Setting Example.....	30
7. Operation.....	31
8. Action Explanations.....	32
8.1 OUT1 Action.....	32
8.2 OUT1 ON/OFF Control Action.....	32
8.3 Heater Burnout Alarm Action.....	33
8.4 Alarm Action.....	33
8.5 OUT2 (Heating/Cooling Control) Action.....	35
8.6 OUT2 Action (When Setting Overlap Band).....	36
8.7 OUT2 Action (When Setting Dead Band).....	37
9. AT (Auto-tuning).....	38
10. Specifications.....	39
10.1 Standard Specifications.....	39
10.2 Optional Specifications.....	42
11. Troubleshooting.....	45
11.1 Indication.....	45
11.2 Key Operation.....	46
11.3 Control.....	47
12. Character Table.....	48
12.1 Main Setting Mode.....	48
12.2 Sub Setting Mode.....	48
12.3 Auxiliary Function Setting Mode 1.....	49
12.4 Auxiliary Function Setting Mode 2.....	50
12.5 Auxiliary Function Setting Mode 3.....	52
Key Operation Flowchart.....	56

1. Model

1.1 Model

DCL - 3 3 A - □ / □ □ , □ □ □		Series name: DCL-300 (W22.5 x H75 x D100mm)
Control action	3	PID
Alarm	A	Selectable by keypad *1
Control output OUT1	R	Relay contact: 1a
	S	Non-contact voltage (for SSR drive): 12 V DC 15%
	A	Direct current: 4 to 20 mA DC
Input	M	Multi-range *2
Power supply voltage		100 to 240 V AC (standard)
	1	24 V AC/DC *3
Option *4	W (5A)	Heater burnout alarm output (5 A)
	W (10A)	Heater burnout alarm output (10 A)
	W (20A)	Heater burnout alarm output (20 A)
	W (50A)	Heater burnout alarm output (50 A)
	DC	Heating/Cooling control output OUT2
	C5	Serial communication EIA RS-485
	EA	External setting input
EI	Set value memory external selection	

*1: Alarm type (12 types and No alarm action) and status Energized/De-energized can be selected by keypad.

*2: Thermocouple, RTD, Direct current and DC voltage can be selected by keypad.

*3: Standard supply voltage is 100 to 240 V AC. Enter "1" after the input code only when ordering 24 V AC/DC.

*4: W, EA, and EI cannot be equipped at the same time as option combinations.

1.2 How to Read the Model Label

The model label is attached to the right side of the case.

(e.g.) DCL-33A-R/M, C5, W (20A)

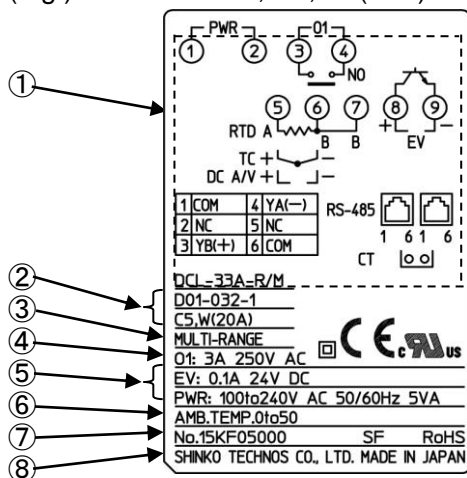

No.	Description	Example
①	Terminal arrangement	DCL-33A-R/M, C5, W(20A) (*1)
②	Model	DCL-33A-R/M, C5, W(20A)
③	Option	C5: Serial communication W(20A): Heater burnout alarm (20 A) (*2)
④	Input	MULTI-RANGE (Multi-range input)
⑤	Control output, Event output	O1: 3 A 250 V AC (Control output OUT1) EV: 0.1 A 24 V DC (Event output EV)
⑥	Power supply, Power consumption	100 to 240 V AC, 50/60 Hz 5 VA
⑦	Recommended ambient temperature	0 to 50
⑧	Serial number	No. 15KF05000

(*1) Terminal arrangement differs depending on the model.

(*2) For Heater burnout alarm output (W option), CT rated current is entered in bracket ().

2. Names and Functions of Controller

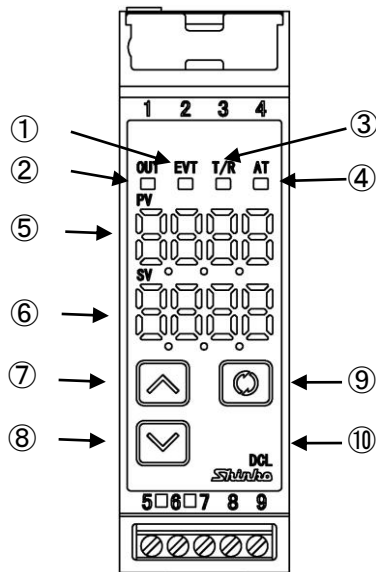

(Fig. 2-1)

No.	Name	Description
①	EVT indicator	The red LED lights up when Event output [Alarm, Loop break alarm or Heater burnout alarm (W option)] is ON. The red LED also lights when control output OUT2 (DC option) is ON.
②	OUT indicator	The green LED lights up when control output OUT1 is ON. For direct current output, flashes in 125 ms cycles corresponding to the output MV.
③	T/R indicator	The yellow LED flashes during serial communication (C5 option) TX output (transmitting).
④	AT indicator	The yellow LED flashes while auto-tuning (AT) is performing.
⑤	PV Display	Indicates the PV (process variable), or setting characters in setting mode with a red LED.
⑥	SV Display	Indicates the SV (desired value), output MV (manipulated variable) or the set value in each setting mode with a green LED.
⑦	UP key	Increases the numeric value.
⑧	DOWN key	Decreases the numeric value.
⑨	MODE key	Switches the setting mode or registers the set data. (Registers the set data by pressing the MODE key.)
⑩	SUB-MODE key	Enters Auxiliary function setting mode 2 in combination with the MODE key. If 'Control output OFF' is selected in [SUB-MODE key function]: Turns all outputs OFF as if the power were turned OFF. If 'Auto/Manual control' is selected in [SUB-MODE key function]: Switches Auto/Manual control. If 'Alarm HOLD cancel' is selected in [SUB-MODE key function]: Cancels Alarm HOLD.

Caution

When setting the specifications and functions of this controller, connect mains power cable to terminals 1 and 2 first, then set them referring to "5. Setup" before performing "3. Mounting to the Control Panel" and "4. Wiring".

3. Mounting to the Control Panel

3.1 Site Selection

This instrument is intended to be used under the following environmental conditions (IEC61010-1): **Overtoltage category** , **Pollution degree 2**

Ensure the mounting location corresponds to the following conditions:

- A minimum of dust, and an absence of corrosive gases
- No flammable, explosive gases
- Few mechanical vibrations or shocks
- No exposure to direct sunlight, an ambient temperature of 0 to 50 (32 to 122) without rapid change, and no icing
- An ambient non-condensing humidity of 35 to 85 %RH
- No large capacity electromagnetic switches or cables through which large current is flowing
- No water, oil, chemicals or the vapors of these substances can come into direct contact with the controller.
- Please note that the ambient temperature of this unit – not the ambient temperature of the control panel – must not exceed 50 (122) if mounted within a control panel, otherwise the life of the electronic components (especially electrolytic capacitors) may be shortened.

3.2 External Dimensions (Scale: mm)

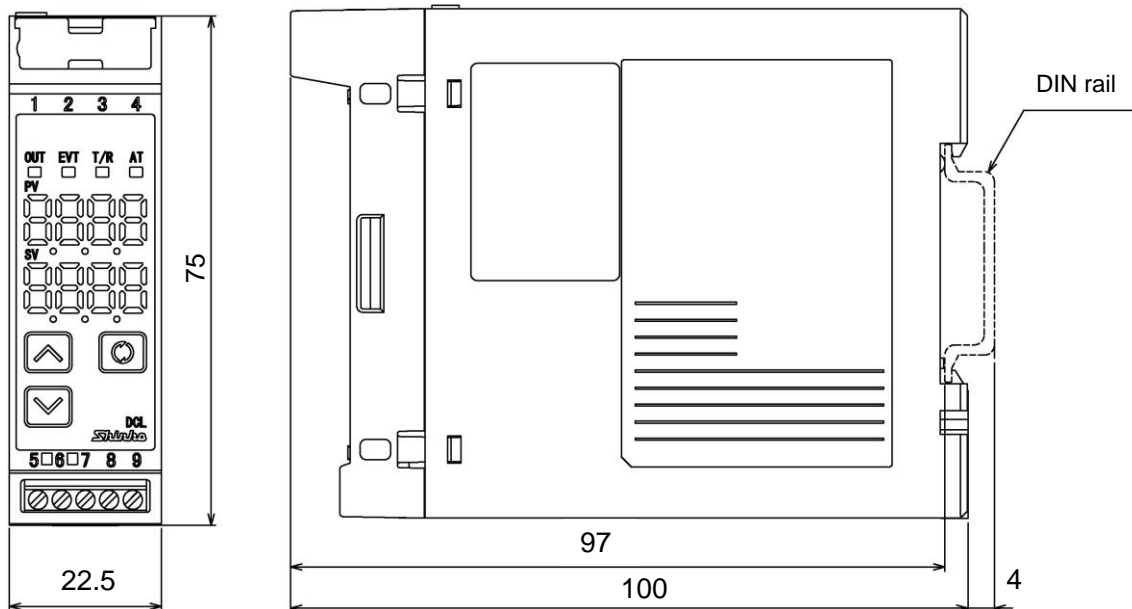

(Fig. 3.2-1)

3.3 CT (Current transformer) External Dimensions (Scale: mm)

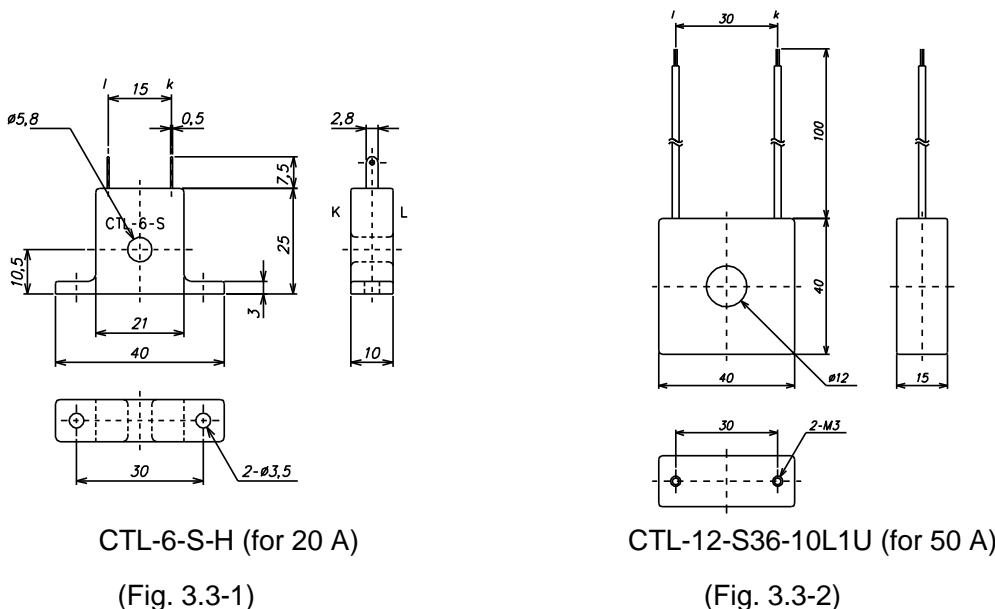

CTL-6-S-H (for 20 A)

(Fig. 3.3-1)

CTL-12-S36-10L1U (for 50 A)

(Fig. 3.3-2)

3.4 Mounting to and Removal from the DIN Rail

Caution

- Mount the DIN rail horizontally.
When the DIN rail is mounted vertically, be sure to use commercially available fastening plates at both ends of the DCL-33A series.
However, if the DIN rail is mounted horizontally in a position susceptible to vibration or shock, the fastening plates must be used as well.
- To remove this instrument, a flat blade screwdriver is required for pulling down the lever.
Never turn the screwdriver when inserting it into the release lever.
If excessive power is applied to the lever, it may break.

• Recommended fastening plate

Manufacturer	Model	
Omron Corporation	End plate	PFP-M
IDEC Corporation	Fastening plate	BNL6
Panasonic Electric Works Co., Ltd.	Fastening plate	ATA4806

Mounting to the DIN rail (Fig. 3.4-1)

First, hook of the DCL-33A on the upper side of the DIN rail.

Second, making part of the DCL-33A as a support, fit the lower part of the DCL-33A to the DIN rail. DCL-33A will be completely fixed to DIN rail with a “Click” sound.

Removal from the DIN rail (Fig. 3.4-2)

Insert a flat blade screwdriver into the release lever, and pull it down.

The lock to the DIN rail will be released, then remove the unit from the DIN rail.

Be sure to hold onto the unit firmly, or it may drop to the ground.

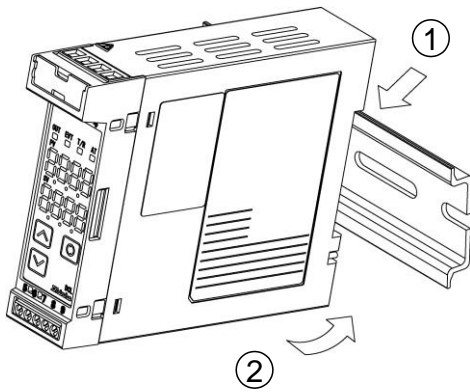

(Fig. 3.4-1) Mounting

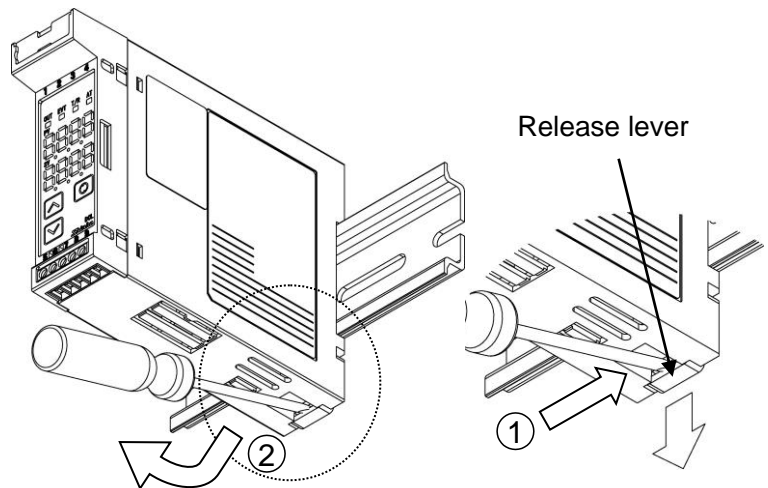

(Fig. 3.4-2) Removal

4. Wiring

Warning

Turn the power supply to the instrument OFF before wiring or checking.
Working on or touching the terminal with the power switched ON may result in severe injury or death due to electrical shock.

Caution

- Do not leave wire remnants in the DCL-33A when wiring, because they could cause a fire or malfunction.
- Insert the connecting cable into the designated connector securely. Not doing so could cause malfunction due to imperfect contact.
- Connect the AC power to the designated terminal as is written in this instruction manual. Otherwise it may burn and damage the DCL-33A.
- Tighten the terminal screw using the specified torque. Excessive force could damage the terminal screw and deface the case.
- Use a thermocouple and compensating lead wire that corresponds to the sensor input specification of this unit.
- Use the 3-wire RTD that corresponds to the sensor input specification of this unit.
- When using DC voltage and current inputs, be careful not to confuse polarity when wiring.
- For a 24 V DC power source, ensure polarity is correct.
- Keep input wires (Thermocouple, RTD, etc.) away from power source and load wires when wiring.
- Do not apply a commercial power source to the sensor connected to the input terminal nor allow the power source to come into contact with the sensor.
- To prevent the unit from harmful effects of unexpected level noise, it is recommended that a surge absorber be installed between the electromagnetic switch coils.
- This unit does not have a built-in power switch, circuit breaker and fuse. Therefore it is necessary to install a power switch, circuit breaker and fuse externally near the controller.
(Recommended fuse: Time-lag fuse, Rated voltage 250 V AC, Rated current 2 A)

When using ferrules, use the following ferrules and crimping pliers made by Phoenix Contact GMBH & CO.

• Recommended ferrules and tightening torque

Terminal number	Terminal screw	Ferrules with insulation sleeve	Conductor cross sections	Tightening torque	Crimping pliers
1 to 4	M2.6	AI 0.25-8 YE	0.2 to 0.25 mm ²	0.5 to 0.6 N•m	CRIMPFOX ZA3 CRIMPFOX UD6
		AI 0.34-8 TQ	0.25 to 0.34 mm ²		
		AI 0.5-8 WH	0.34 to 0.5 mm ²		
		AI 0.75-8 GY	0.5 to 0.75 mm ²		
		AI 1.0-8 RD	0.75 to 1.0 mm ²		
		AI 1.5-8 BK	1.0 to 1.5 mm ²		
5 to 9	M2.0	AI 0.25-8 YE	0.2 to 0.25 mm ²	0.22 to 0.25 N•m	
		AI 0.34-8 TQ	0.25 to 0.34 mm ²		
		AI 0.5-8 WH	0.34 to 0.5 mm ²		

4.1 Terminal Arrangement

(Fig. 4.1-1)

Name	Description
PWR	Power supply: 100 to 240 V AC or 24 V AC/DC For 24 V DC, ensure polarity is correct.
O1	Control output OUT1
TC	Thermocouple input
RTD	Resistance temperature detector input
DC	Direct current input, DC voltage input (*1)
EV	Event output Outputs when Alarm, Loop break alarm or Heater burnout alarm output (W option) is ON.
O2	Control output OUT2 [Heating/Cooling control output (DC option)]
RS-485	Serial communication (C5 option)
CT	Current transformer input [Heater burnout alarm output (W option)]
EA	External setting input (EA option)
EI	Event input DI [Set value memory external selection (EI option)]

(*1) If direct current input (Externally mounted 50 Ω shunt resistor) is designated, connect a 50 Ω shunt resistor (sold separately) between input terminals.

4.2 Heater Burnout Alarm Output (W option)

This alarm is not available for detecting current under phase control.

Use the current transformer (CT) provided, and pass one lead wire of the heater circuit into the hole of the CT. When wiring, keep the CT wire away from any AC source or load wires to avoid the external interference.

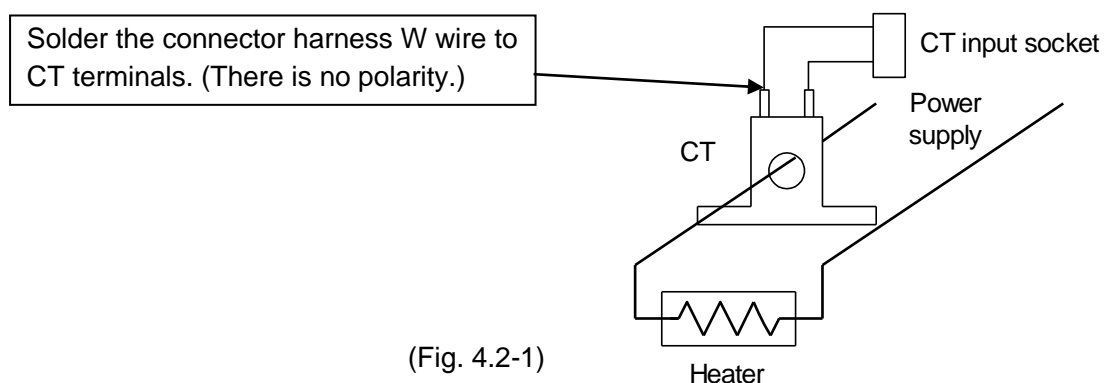

(Fig. 4.2-1)

5. Setup

Connect mains power cable to terminals 1 and 2, and turn the power ON.

The PV Display indicates sensor input characters and temperature unit, and the SV Display indicates the input range high limit value for approx. 3 seconds. (Table 5-1)

(If any other value is set in [Scaling high limit], the SV Display indicates the value.)

During this time all outputs and the LED indicators are in OFF status.

After that, the control starts, indicating PV (process variable) on the PV Display, and SV (desired value) on the SV Display.

(Table 5-1)

Input Type	Input Range		Resolution
K	-200 to 1370	-320 to 2500	1 ()
	-199.9 to 400.0	-199.9 to 750.0	0.1 ()
J	-200 to 1000	-320 to 1800	1 ()
R	0 to 1760	0 to 3200	1 ()
S	0 to 1760	0 to 3200	1 ()
B	0 to 1820	0 to 3300	1 ()
E	-200 to 800	-320 to 1500	1 ()
T	-199.9 to 400.0	-199.9 to 750.0	0.1 ()
N	-200 to 1300	-320 to 2300	1 ()
PL-	0 to 1390	0 to 2500	1 ()
C (W/Re5-26)	0 to 2315	0 to 4200	1 ()
Pt100	-199.9 to 850.0	-199.9 to 999.9	0.1 ()
	-200 to 850	-300 to 1500	1 ()
JPt100	-199.9 to 500.0	-199.9 to 900.0	0.1 ()
	-200 to 500	-300 to 900	1 ()
4 to 20 mA DC	-1999 to 9999 (*1), (*2)		1
0 to 20 mA DC	-1999 to 9999 (*1), (*2)		1
0 to 1 V DC	-1999 to 9999 (*1)		1
0 to 5 V DC	-1999 to 9999 (*1)		1
1 to 5 V DC	-1999 to 9999 (*1)		1
0 to 10 V DC	-1999 to 9999 (*1)		1
4 to 20 mA DC	-1999 to 9999 (*1), (*3)		1
0 to 20 mA DC	-1999 to 9999 (*1), (*3)		1

(*1) Input range and decimal point place can be changed.

(*2) Connect a 50 Ω shunt resistor (sold separately) between input terminals.

(*3) This input type has a built-in shunt resistor (50 Ω).

5.1 Main Setting Mode

Character	Setting Item, Description, Setting Range	Factory Default
	SV1 <ul style="list-style-type: none"> • Sets the SV1 (desired value) for control target. • Setting range: Scaling low limit to scaling high limit (For DC voltage and current inputs, the placement of the decimal point follows the selection.) 	0

5.2 Sub Setting Mode

Character	Setting Item, Description, Setting Range	Factory Default
	AT Perform/Cancel <ul style="list-style-type: none"> • Selects AT (auto-tuning) Perform/Cancel. AT will be forced to stop if it has not been completed within 4 hours. • AT will stop in the following cases. <ul style="list-style-type: none"> - Direct/Reverse action in Event input DI is changed. - Control ON/OFF in Event input DI is changed. - Preset output 2 in Event input DI is turned ON. - Auto/Manual control in Event input DI is changed. - 'Integral action Holding (Stop)' is selected in Event input DI - For DC input and direct current output: When 'Output ON' is selected in [Output status when input errors occur], and if input errors occur. • : AT Cancel, : AT Perform 	AT Cancel
	OUT1 proportional band <ul style="list-style-type: none"> • Sets OUT1 proportional band. • ON/OFF control when set to 0.0. • Setting range: 0.0 to 110.0% 	2.5%
	OUT2 proportional band <ul style="list-style-type: none"> • Sets OUT2 proportional band. • OUT2 proportional band: Multiplied value of OUT1 proportional band. ON/OFF control when set to 0.0. • Available only when Heating/Cooling control output (DC option) is ordered. Not available if OUT1 is in ON/OFF control • Setting range: 0.0 to 10.0 times 	1.0 times
	Integral time <ul style="list-style-type: none"> • Sets the integral time. • Setting the value to 0 disables this function. • Not available if OUT1 is in ON/OFF control. • Setting range: 0 to 3600 seconds 	200 seconds
	Derivative time <ul style="list-style-type: none"> • Sets the derivative time. • Setting the value to 0 disables this function. • Not available if OUT1 is in ON/OFF control. • Setting range: 0 to 1800 seconds 	50 seconds
	ARW (Anti-reset windup) <ul style="list-style-type: none"> • Sets anti-reset windup. • Available only for PID control. • Setting range: 0 to 100% 	50%
	OUT1 proportional cycle <ul style="list-style-type: none"> • Sets the OUT1 proportional cycle. • Not available if OUT1 is in ON/OFF control. Not available for direct current output. • Setting range: 1 to 120 seconds 	Relay contact output: 30 seconds Non-contact voltage output: 3 seconds
	OUT2 proportional cycle <ul style="list-style-type: none"> • Sets the OUT2 proportional cycle. • Available only when Heating/Cooling control output (DC option) is ordered. Not available if OUT2 is in ON/OFF control. • Setting range: 1 to 120 seconds 	3 seconds
	Manual reset <ul style="list-style-type: none"> • Sets the reset value manually. • Available only for P or PD control. • Setting range: Proportional band converted value (For DC voltage and current inputs, the placement of the decimal point follows the selection.) 	0.0

Character	Setting Item, Description, Setting Range	Factory Default
	Alarm 1 value <ul style="list-style-type: none"> • Sets Alarm 1 action point. • Alarm 1 value matches Alarm 1 low limit alarm value in the following cases: When 'High/Low limits independent alarm', 'High/Low limit range independent alarm' or 'High/Low limits with standby independent alarm' is selected in [Alarm 1 type]. • When Alarm, Loop break alarm and Heater burnout alarm (W option) are used together, they utilize common output terminals. • Not available if No alarm action is selected in [Alarm 1 type]. • Setting range: See (Table 5.2-1). (For DC voltage and current inputs, the placement of the decimal point follows the selection.) 	0
. and XX.X alternating display	Heater burnout alarm value <ul style="list-style-type: none"> • Sets the heater current value for Heater burnout alarm. • Setting the value to 0.0 disables Heater burnout alarm action. • Upon returning to set limits, the alarm will stop. When Heater burnout alarm, Alarm and Loop break alarm are used together, they utilize common output terminals. • Available only when Heater burnout alarm (W option) is ordered. • Rated current 5 A: 0.0 to 5.0 A Rated current 10A: 0.0 to 10.0 A Rated current 20A: 0.0 to 20.0 A Rated current 50A: 0.0 to 50.0 A 	0.0 A
	Loop break alarm time <ul style="list-style-type: none"> • Sets the time to assess the Loop break alarm. (See "Loop break alarm" on p.18.) • Setting the value to 0 disables Loop break alarm. • When Loop break alarm, Alarm and Heater burnout alarm are used together, they utilize common output terminals. • Setting range: 0 to 200 minutes 	0 minutes
	Loop break alarm band <ul style="list-style-type: none"> • Sets the band to assess the Loop break alarm. (See "Loop break alarm" on p.18.) • Setting the value to 0 disables Loop break alarm. • When Loop break alarm, Alarm and Heater burnout alarm are used together, they utilize common output terminals. • Setting range: Thermocouple, RTD inputs: 0 to 150 () or 0.0 to 150.0 () DC voltage, current inputs: 0 to 1500 (The placement of the decimal point follows the selection.) 	0

(Table 5.2-1)

Alarm Type	Setting Range	
High limit alarm	-(Scaling span) to scaling span	If the scaling span exceeds 199.9 or 1999, the lower limit of the - side setting is -199.9 or 1999.
Low limit alarm	-(Scaling span) to scaling span	
High/Low limits alarm	0 to scaling span	
High/Low limit range alarm	0 to scaling span	
Process high alarm	Scaling low limit value to scaling high limit value	
Process low alarm	Scaling low limit value to scaling high limit value	If the scaling span exceeds 999.9 or 9999, the upper limit of the + side setting is 999.9 or 9999.
High limit with standby alarm	-(Scaling span) to scaling span	
Low limit with standby alarm	-(Scaling span) to scaling span	
High/Low limits with standby alarm	0 to scaling span	
High/Low limits independent alarm	0 to scaling span	
High/Low limit range independent alarm	0 to scaling span	
High/Low limits with standby independent alarm	0 to scaling span	

5.3 Auxiliary Function Setting Mode 1

Character	Setting Item, Description, Setting Range	Factory Default
	<p>Set value lock</p> <ul style="list-style-type: none"> Locks the set values to prevent setting errors. The setting item to be locked depends on the selection. Auto-tuning (AT) cannot be carried out if Lock 1 or Lock 2 is selected. <ul style="list-style-type: none"> (Unlock): All set values can be changed. (Lock 1): None of the set values can be changed. (Lock 2): Only main setting mode can be changed. (Lock 3): All set values – except input type and Controller/Converter – can be changed. However, changed values revert to their previous values after power is turned off because they are not saved in the non-volatile IC memory. <p>Do not change any setting item in Auxiliary function setting mode 2. If any item in Auxiliary function setting mode 2 is changed, it will affect other setting items such as the SV and Alarm value. Be sure to select Lock 3 when changing the set value frequently via software communication. (If a value set by the software communication is the same as the value before the setting, the value will not be written in non-volatile IC memory.)</p>	Unlock
	<p>Sensor correction</p> <ul style="list-style-type: none"> Sets the sensor correction value. (For details, see ‘Sensor correction function’ on p.18.) Setting range: Thermocouple, RTD inputs: –100.0 to 100.0 () DC voltage, current inputs: –1000 to 1000 (The placement of the decimal point follows the selection.) 	0.0°C
	<p>Communication protocol</p> <ul style="list-style-type: none"> Selects communication protocol. Available only when serial communication (C5 option) is ordered. <ul style="list-style-type: none"> : Shinko protocol : MODBUS ASCII mode : MODBUS RTU mode : Shinko protocol (Block Read/Write available) : MODBUS ASCII mode (Block Read/Write available) : MODBUS RTU mode (Block Read/Write available) 	Shinko protocol
	<p>Instrument number</p> <ul style="list-style-type: none"> Sets an individual instrument number for each DCL-33A when connecting multiple DCL-33A units in serial communication. Available only when serial communication (C5 option) is ordered. Setting range: 0 to 95 	0
	<p>Communication speed</p> <ul style="list-style-type: none"> Selects the speed in accordance with the host computer. Available only when serial communication (C5 option) is ordered. <ul style="list-style-type: none"> : 2400 bps : 4800 bps : 9600 bps : 19200 bps : 38400 bps 	9600 bps
	<p>Parity</p> <ul style="list-style-type: none"> Selects the parity. Available only when serial communication (C5 option) is ordered. Not available if Shinko protocol is selected in [Communication protocol]. <ul style="list-style-type: none"> : No parity : Even : Odd 	Even
	<p>Stop bit</p> <ul style="list-style-type: none"> Selects the stop bit. Available only when serial communication (C5 option) is ordered. Not available if Shinko protocol is selected in [Communication protocol]. Selection: 1 bit or 2 bits 	1 bit

5.4 Auxiliary Function Setting Mode 2

Character	Setting Item, Description, Setting Range	Factory Default																																																												
	Input type • Selects a sensor type and temperature unit from thermocouple (10 types), RTD (2 types), Direct current (4 types) and DC voltage (4 types) and / . • When changing input from DC voltage to other inputs, detach the sensor connected to this controller, then change the input. The input circuit may break if the input is changed with the sensor connected.	K (-200 to 1370)																																																												
	<table border="1"> <tbody> <tr> <td>K</td> <td>-200 to 1370</td> <td>K</td> <td>-320 to 2500</td> </tr> <tr> <td></td> <td>-199.9 to 400.0</td> <td></td> <td>-199.9 to 750.0</td> </tr> <tr> <td>J</td> <td>-200 to 1000</td> <td>J</td> <td>-320 to 1800</td> </tr> <tr> <td>R</td> <td>0 to 1760</td> <td>R</td> <td>0 to 3200</td> </tr> <tr> <td>S</td> <td>0 to 1760</td> <td>S</td> <td>0 to 3200</td> </tr> <tr> <td>B</td> <td>0 to 1820</td> <td>B</td> <td>0 to 3300</td> </tr> <tr> <td>E</td> <td>-200 to 800</td> <td>E</td> <td>-320 to 1500</td> </tr> <tr> <td>T</td> <td>-199.9 to 400.0</td> <td>T</td> <td>-199.9 to 750.0</td> </tr> <tr> <td>N</td> <td>-200 to 1300</td> <td>N</td> <td>-320 to 2300</td> </tr> <tr> <td>PL-</td> <td>0 to 1390</td> <td>PL-</td> <td>0 to 2500</td> </tr> <tr> <td>C (W/Re5-26)</td> <td>0 to 2315</td> <td>C (W/Re5-26)</td> <td>0 to 4200</td> </tr> <tr> <td>Pt100</td> <td>-199.9 to 850.0</td> <td>Pt100</td> <td>-199.9 to 999.9</td> </tr> <tr> <td>JPt100</td> <td>-199.9 to 500.0</td> <td>JPt100</td> <td>-199.9 to 900.0</td> </tr> <tr> <td>Pt100</td> <td>-200 to 850</td> <td>Pt100</td> <td>-300 to 1500</td> </tr> <tr> <td>JPt100</td> <td>-200 to 500</td> <td>JPt100</td> <td>-300 to 900</td> </tr> </tbody> </table>	K	-200 to 1370	K	-320 to 2500		-199.9 to 400.0		-199.9 to 750.0	J	-200 to 1000	J	-320 to 1800	R	0 to 1760	R	0 to 3200	S	0 to 1760	S	0 to 3200	B	0 to 1820	B	0 to 3300	E	-200 to 800	E	-320 to 1500	T	-199.9 to 400.0	T	-199.9 to 750.0	N	-200 to 1300	N	-320 to 2300	PL-	0 to 1390	PL-	0 to 2500	C (W/Re5-26)	0 to 2315	C (W/Re5-26)	0 to 4200	Pt100	-199.9 to 850.0	Pt100	-199.9 to 999.9	JPt100	-199.9 to 500.0	JPt100	-199.9 to 900.0	Pt100	-200 to 850	Pt100	-300 to 1500	JPt100	-200 to 500	JPt100	-300 to 900	
K	-200 to 1370	K	-320 to 2500																																																											
	-199.9 to 400.0		-199.9 to 750.0																																																											
J	-200 to 1000	J	-320 to 1800																																																											
R	0 to 1760	R	0 to 3200																																																											
S	0 to 1760	S	0 to 3200																																																											
B	0 to 1820	B	0 to 3300																																																											
E	-200 to 800	E	-320 to 1500																																																											
T	-199.9 to 400.0	T	-199.9 to 750.0																																																											
N	-200 to 1300	N	-320 to 2300																																																											
PL-	0 to 1390	PL-	0 to 2500																																																											
C (W/Re5-26)	0 to 2315	C (W/Re5-26)	0 to 4200																																																											
Pt100	-199.9 to 850.0	Pt100	-199.9 to 999.9																																																											
JPt100	-199.9 to 500.0	JPt100	-199.9 to 900.0																																																											
Pt100	-200 to 850	Pt100	-300 to 1500																																																											
JPt100	-200 to 500	JPt100	-300 to 900																																																											
	4 to 20 mA -1999 to 9999 (Externally mounted 50 shunt resistor) 0 to 20 mA -1999 to 9999 (Externally mounted 50 shunt resistor) 0 to 1 V -1999 to 9999 0 to 5 V -1999 to 9999 1 to 5 V -1999 to 9999 0 to 10 V -1999 to 9999 4 to 20 mA -1999 to 9999 (Built-in 50 shunt resistor) 0 to 20 mA -1999 to 9999 (Built-in 50 shunt resistor)																																																													
	Scaling high limit • Sets the scaling high limit value. • Setting range: Scaling low limit to input range high limit (For DC voltage, current inputs, the placement of the decimal point follows the selection.)	1370																																																												
	Scaling low limit • Sets the scaling low limit value. • Setting range: Input range low limit to scaling high limit (For DC voltage, current inputs, the placement of the decimal point follows the selection.)	-200																																																												
	Decimal point place • Selects the decimal point place. Not available if thermocouple or RTD is selected in [input type]. • : No decimal point : 1 digit after decimal point : 2 digits after decimal point : 3 digits after decimal point	No decimal point																																																												
	PV filter time constant • Sets the PV filter time constant. If the set value is too large, it affects control results due to the response delay. • Setting range: 0.0 to 10.0 seconds	0.0 seconds																																																												
	OUT1 high limit • Sets the OUT1 high limit value. • Available for direct current output. Not available if OUT1 is in ON/OFF control. • Setting range: OUT1 low limit value to 100% (Direct current output type: OUT1 low limit value to 105%)	100%																																																												

Character	Setting Item, Description, Setting Range	Factory Default
	OUT1 low limit • Sets the OUT1 low limit value. • Available for direct current output. Not available if OUT1 is in ON/OFF control. • Setting range: 0% to OUT1 high limit value (Direct current output type: -5% to OUT1 high limit value)	0%
	OUT1 ON/OFF hysteresis • Sets the ON/OFF hysteresis for the OUT1. • Available only for ON/OFF control (P=0). • Setting range: Thermocouple, RTD inputs: 0.1 to 100.0 () DC voltage, current inputs: 1 to 1000 (The placement of the decimal point follows the selection.)	1.0
	OUT2 cooling method • Selects air, oil or water cooling for OUT2 action. • Available only when Heating/Cooling control (DC option) is ordered. Not available if OUT2 is in ON/OFF control action • : Air cooling : Oil cooling : Water cooling	Air cooling
	OUT2 high limit • Sets OUT2 high limit value. • Available only when Heating/Cooling control (DC option) is ordered. Not available if OUT2 is in ON/OFF control action • Setting range: OUT2 low limit value to 100%	100%
	OUT2 low limit • Sets OUT2 low limit value. • Available only when Heating/Cooling control (DC option) is ordered. Not available if OUT2 is in ON/OFF control action • Setting range: 0% to OUT2 high limit value	0%
	Overlap/Dead band • Sets Overlap/Dead band. • Available only when Heating/Cooling control (DC option) is ordered. Not available if OUT2 is in ON/OFF control action • Setting range: Thermocouple, RTD inputs: -100.0 to 100.0 () DC voltage, current inputs: 1 to 1000 (The placement of the decimal point follows the selection.)	0.0
	OUT2 ON/OFF hysteresis • Sets the ON/OFF action hysteresis for the OUT2. • Available only when Heating/Cooling control (DC option) is ordered. Available only when OUT2 is in ON/OFF control action (P=0). • Setting range: Thermocouple, RTD inputs: 0.1 to 100.0 () DC voltage, current inputs: 1 to 1000 (The placement of the decimal point follows the selection)	1.0
	Alarm 1 type • Selects an Alarm 1 type. Note: If Alarm 1 type is changed, Alarm 1 value defaults to 0 (0.0). • : No alarm action : High limit alarm : Low limit alarm : High/Low limits alarm : High/Low limit range alarm : Process high alarm : Process low alarm : High limit with standby alarm : Low limit with standby alarm : High/Low limits with standby alarm : High/Low limits independent alarm : High/Low limit range independent alarm : High/Low limits with standby independent alarm	No alarm action

Character	Setting Item, Description, Setting Range	Factory Default
	Alarm 1 Energized/De-energized • Selects Alarm 1 action Energized/De-energized. (For details, see p.18.) • Not available if No alarm action is selected in [Alarm 1 type]. • : Energized : De-energized	Energized
	Alarm 1 HOLD function • Selects either Holding or Not holding in Alarm 1. If “Holding” is set, once alarm is activated, the alarm output remains ON until the power is turned off. • Not available if No alarm action is selected in [Alarm 1 type]. • : Not holding : Holding	Not holding
	Alarm 1 hysteresis • Sets Alarm 1 hysteresis. • Not available if No alarm action is selected in [Alarm 1 type]. • Setting range: Thermocouple, RTD inputs: 0.1 to 100.0 () DC voltage, current inputs: 1 to 1000 (The placement of the decimal point follows the selection.)	1.0
	Alarm 1 delay time • Sets Alarm 1 action delay time. When the setting time has elapsed after the input enters the alarm output range, the alarm is activated. • Not available if No alarm action is selected in [Alarm 1 type]. • Setting range: 0 to 9999 seconds	0 seconds
	Direct/Reverse action • Selects either Reverse (Heating) or Direct (Cooling) control action. • : Reverse (Heating) action : Direct (Cooling) action	Reverse (Heating) action
	AT bias • Set the AT (auto-tuning) bias value. • Not available if DC voltage or current input is selected in [Input type]. Available only for PID control action • Setting range: 0 to 50 (0 to 100) or 0.0 to 50.0 (0.0 to 100.0)	20
	SVTC bias • Control desired value adds SVTC bias value to the value received by the SVTC command. • Available only when serial communication (C5 option) is ordered. • Setting range: 20% of the scaling span	0
	Output status when input errors occur • Selects the output status of OUT1 when DC input is in overscale or underscale. (See “Output status when input errors occur” on p.18.) • Available only for DC input and direct current output. • : Output OFF: Outputs OFF (4 mA) or OUT1 low limit value. : Output ON: Outputs a value between OFF (4 mA) and ON (20 mA) or between OUT1 low limit value and OUT1 high limit value, depending on deviation.	Output OFF
	Controller/Converter • Selects either controller or converter function. (See “6. Simplified Converter Function” on pages 27 to 29.) • Available only for direct current output type. • : Controller, : Converter	Controller

Sensor correction function

This corrects the input value from the sensor. When a sensor cannot be set at the exact location where control is desired, the sensor-measured temperature may deviate from the temperature in the controlled location.

When using multiple controllers, sometimes the measured temperatures (input value) do not match (even if SV is the same value) due to differences in sensor accuracy or dispersion of load capacities. In such a case, the control can be set at the desired temperature by adjusting the input value of sensors. However, it is effective within the input rated range regardless of the sensor correction value.
 PV after sensor correction = Current PV + (Sensor correction value)

Loop break alarm

The alarm will be activated if the PV (process variable) does not **reach** the Loop break alarm band setting within the time allotted to assess the Loop break alarm after the MV (manipulated variable) has reached 100% or the control output high limit value. The alarm will also be activated if the PV (process variable) does not **drop to** the Loop break alarm band setting within the time allotted to assess the Loop break alarm after the MV has reached 0% or the control output low limit value. When the control action is Direct (Cooling), read “**drop to**” for “**reach**” and vice versa.

Energized/De-energized

[If alarm action Energized is selected]

When the alarm output indicator is lit, the alarm output (between terminals 8 and 9) is conducted (ON). When the alarm output indicator is unlit, the alarm output is not conducted (OFF).

[If alarm action De-energized is selected]

When the alarm output indicator is lit, the alarm output (between terminals 8 and 9) is not conducted (OFF). When the alarm output indicator is unlit, the alarm output is conducted (ON).

High limit alarm (Energized setting)

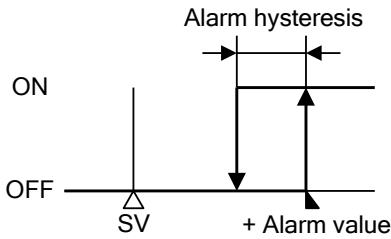

(Fig. 5.4-1)

High limit alarm (De-energized setting)

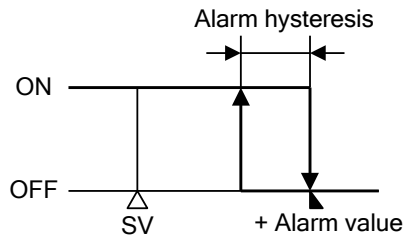

(Fig. 5.4-2)

Output status when input errors occur

Control output status differs depending on the selection in [Output status when input errors occur] as follows.

Output status when input errors occur (*1)	Contents and Indication	Output status					
		Controller/Converter					
		Controller				Converter	
		OUT1		OUT2		OUT1	
		Direct action	Reverse action	Direct	Reverse	Direct	Reverse
	When [] flashes.	ON (20 mA) or OUT1 high limit value (*2)	OFF (4 mA) or OUT1 low limit value	OUT2 low limit value		20 mA or OUT1 high limit value	4 mA or OUT1 low limit value
	When [] flashes.	OFF (4 mA) or OUT1 low limit value	ON (20 mA) or OUT1 high limit value (*2)	OUT2 low limit value		4 mA or OUT1 low limit value	20 mA or OUT1 high limit value

(*1) [Output status when input errors occur] can be used only for controllers using direct current and voltage inputs, and direct current output.

If OUT1 is not Direct current output, the output status will be the same as when [] is selected in [Output status when input errors occur].

For manual control, the preset MV is output.

(*2) Outputs a value between OFF (4 mA) and ON (20 mA) or between OUT1 low limit value and OUT1 high limit value, depending on deviation.

5.5 Auxiliary Function Setting Mode 3

Character	Setting Item, Description, Setting Range			Factory Default
	Event input DI allocation • Selects Event input DI function from the following. • Available only when Set value memory external selection (EI option) is selected.			No event
	Event Input Function	Input ON (Closed)	Input OFF (Open)	Remarks
	No event			
	Set value memory	SV2	SV1	SV1/SV2 selectable
	Control ON/OFF (*1)	Control OFF	Control ON	Control ON/OFF selectable
	Direct/Reverse action	Direct	Reverse	Direct/Reverse control selectable
	Preset output 1 ON/OFF	Preset output	Usual control	If sensor is burnt out, the unit maintains control with the preset MV.
	Preset output 2 ON/OFF	Preset output	Usual control	The unit maintains control with the preset MV.
	Auto/Manual control (*2)	Manual	Automatic	Auto/Manual control selectable
	Integral action Holding (Stop)/Usual integral action	Integral action Holding(Stop)	Usual integral action	Control continues with the integral value being held.
	Set value memory	SV1	SV2	
	Control ON/OFF (*1)	Control ON	Control OFF	
	Direct/Reverse action	Reverse	Direct	
	Preset output 1 ON/OFF	Usual control	Preset output	
	Preset output 2 ON/OFF	Usual control	Preset output	
	Auto/Manual control (*2)	Automatic	Manual	
	Integral action Holding (Stop)/Usual integral action	Usual integral action	Integral action Holding (Stop)	
	to : Selected functions work when Event input DI is closed. to : Selected functions work when Event input DI is open. (*1) When selecting Control ON/OFF, if 'Control output OFF' has not been selected in [SUB-MODE key function], Event input DI allocation will return to No event. (*2) When selecting Auto/Manual control, if 'Auto/Manual control' has not been selected in [SUB-MODE key function], Event input DI allocation will return to No event.			
	SV2 • Sets SV2 (the 2 nd desired value). • Available when Set value memory external selection (EI option) is ordered. • Available when 001 or 008 is selected in [Event input DI allocation]. • Setting range: Scaling low limit to Scaling high limit			0

Character	Setting Item, Description, Setting Range	Factory Default
	<p>Alarm 1 value 0 Enabled/Disabled</p> <ul style="list-style-type: none"> • Selects Alarm 1 action Enabled or Disabled when Alarm 1 value is 0 (zero). • Not available if No alarm action is selected in [Alarm 1 type]. • Invalidated for Process alarm • : Disabled • : Enabled 	Disabled
	<p>Alarm 1 high limit alarm value</p> <ul style="list-style-type: none"> • Sets Alarm 1 high limit alarm value. • Available when 'High/Low limits independent alarm', 'High/Low limit range independent alarm' or 'High/Low limits with standby independent alarm' is selected in [Alarm 1 type]. • Setting range: See (Table 5.2-1) on p.13. (For DC voltage and current inputs, the placement of the decimal point follows the selection) 	0
	<p>Alarm 2 type</p> <ul style="list-style-type: none"> • Selects an Alarm 2 type. <p>Note: If Alarm 2 type is changed, Alarm 2 value defaults to 0 (0.0).</p> <ul style="list-style-type: none"> • : No alarm action • : High limit alarm • : Low limit alarm • : High/Low limits alarm • : High/Low limit range alarm • : Process high alarm • : Process low alarm • : High limit with standby alarm • : Low limit with standby alarm • : High/Low limits with standby alarm • : High/Low limits independent alarm • : High/Low limit range independent alarm • : High/Low limits with standby independent alarm 	No alarm action
	<p>Alarm 2 value 0 Enabled/Disabled</p> <ul style="list-style-type: none"> • Selects Alarm 2 action Enabled or Disabled when Alarm 2 value is 0 (zero). • Not available if No alarm action is selected in [Alarm 2 type]. • Invalidated for Process alarm • : Disabled • : Enabled 	Disabled
	<p>Alarm 2 value</p> <ul style="list-style-type: none"> • Sets Alarm 2 action point. • Alarm 2 value matches Alarm 2 low limit alarm value in the following cases: When 'High/Low limits independent alarm', 'High/Low limit range independent alarm' or 'High/Low limits with standby independent alarm' is selected in [Alarm 2 type]. • When Alarm, Loop break alarm and Heater burnout alarm are used together, they utilize common output terminals. • Not available if No alarm action is selected in [Alarm 2 type]. • Setting range: See (Table 5.2-1) on p.13. (For DC voltage and current inputs, the placement of the decimal point follows the selection.) 	0
	<p>Alarm 2 high limit alarm value</p> <ul style="list-style-type: none"> • Sets Alarm 2 high limit alarm value. • Available when 'High/Low limits independent alarm', 'High/Low limit range independent alarm' or 'High/Low limits with standby independent alarm' is selected in [Alarm 2 type]. • Setting range: See (Table 5.2-1) on p.13. (For DC voltage and current inputs, the placement of the decimal point follows the selection) 	0

Character	Setting Item, Description, Setting Range	Factory Default
<i>A2Lā</i>	Alarm 2 Energized/De-energized <ul style="list-style-type: none"> • Selects Alarm 2 action Energized/De-energized. (For details, see p.18.) • Not available if No alarm action is selected in [Alarm 2 type]. • <i>noāL</i> : Energized • <i>rĒBĦ</i>: De-energized 	Energized
<i>A2Hd</i>	Alarm 2 HOLD function <ul style="list-style-type: none"> • Selects either Holding or Not holding in Alarm 2. When "Holding" is set, once alarm is activated, the alarm output remains ON until the power is turned off. • Not available if No alarm action is selected in [Alarm 2 type]. • <i>nonĒ</i> : Not holding • <i>Hold</i>: Holding 	Not holding
<i>A2HŸ</i>	Alarm 2 hysteresis <ul style="list-style-type: none"> • Sets Alarm 2 hysteresis. • Not available if No alarm action is selected in [Alarm 2 type]. • Setting range: Thermocouple, RTD inputs: 0.1 to 100.0°C (°F) DC voltage, current inputs: 1 to 1000 (The placement of the decimal point follows the selection.) 	1.0°C
<i>A2dŸ</i>	Alarm 2 delay time <ul style="list-style-type: none"> • Sets Alarm 2 action delay time. When the setting time has elapsed after the input enters the alarm output range, the alarm is activated. • Not available if No alarm action is selected in [Alarm 2 type]. • Setting range: 0 to 9999 seconds 	0 seconds
<i>AL3F</i>	Alarm 3 type <ul style="list-style-type: none"> • Selects an Alarm 3 type. Note: If Alarm 3 type is changed, Alarm 3 value defaults to 0 (0.0). • <i>----</i> : No alarm action • <i>H□□□</i>: High limit alarm • <i>L□□□</i>: Low limit alarm • <i>HL□□</i>: High/Low limits alarm • <i>Ÿl d□</i>: High/Low limit range alarm • <i>AŸ□□</i>: Process high alarm • <i>rAŸ□</i>: Process low alarm • <i>H□□Ÿ</i>: High limit with standby alarm • <i>L□□Ÿ</i>: Low limit with standby alarm • <i>HL□□Ÿ</i>: High/Low limits with standby alarm • <i>l HL□□</i>: High/Low limits independent alarm • <i>l Ÿl d□</i>: High/Low limit range independent alarm • <i>l HL□□Ÿ</i>: High/Low limits with standby independent alarm 	No alarm action
<i>A3ĒA</i>	Alarm 3 value 0 Enabled/Disabled <ul style="list-style-type: none"> • Selects Alarm 3 action Enabled or Disabled when Alarm 3 value is 0 (zero). • Not available if No alarm action is selected in [Alarm 3 type]. • Invalidated for Process alarm • <i>no□□</i>: Disabled • <i>ŸĒ□□</i>: Enabled 	Disabled

Character	Setting Item, Description, Setting Range	Factory Default
A3	Alarm 3 value <ul style="list-style-type: none"> • Sets Alarm 3 action point. • Alarm 3 value matches Alarm 3 low limit alarm value in the following cases: When ‘High/Low limits independent alarm’, ‘High/Low limit range independent alarm’ or ‘High/Low limits with standby independent alarm’ is selected in [Alarm 3 type]. • When Alarm, Loop break alarm and Heater burnout alarm are used together, they utilize common output terminals. • Not available if No alarm action is selected in [Alarm 3 type]. • Setting range: See (Table 5.2-1) on p.13. (For DC voltage and current inputs, the placement of the decimal point follows the selection.) 	0°C
A3H	Alarm 3 high limit alarm value <ul style="list-style-type: none"> • Sets Alarm 3 high limit alarm value. • Available when ‘High/Low limits independent alarm’, ‘High/Low limit range independent alarm’ or ‘High/Low limits with standby independent alarm’ is selected in [Alarm 3 type]. • Setting range: See (Table 5.2-1) on p.13. (For DC voltage and current inputs, the placement of the decimal point follows the selection) 	0°C
A3L	Alarm 3 Energized/De-energized <ul style="list-style-type: none"> • Selects Alarm 3 action Energized/De-energized. (For details, see p.18.) • Not available if No alarm action is selected in [Alarm 3 type]. • <i>noNL</i>: Energized <i>rEB4</i>: De-energized 	Energized
A3Hd	Alarm 3 HOLD function <ul style="list-style-type: none"> • Selects either Holding or Not holding in Alarm 3. When “Holding” is set, once alarm is activated, the alarm output remains ON until the power is turned off. • Not available if No alarm action is selected in [Alarm 3 type]. • <i>nonE</i>: Not holding <i>HoLd</i>: Holding 	Not holding
A3HY	Alarm 3 hysteresis <ul style="list-style-type: none"> • Sets Alarm 3 hysteresis. • Not available if No alarm action is selected in [Alarm 3 type]. • Setting range: Thermocouple, RTD inputs: 0.1 to 100.0°C (°F) DC voltage, current inputs: 1 to 1000 (The placement of the decimal point follows the selection.) 	1.0°C
A3dY	Alarm 3 delay time <ul style="list-style-type: none"> • Sets Alarm 3 action delay time. When the setting time has elapsed after the input enters the alarm output range, the alarm is activated. • Not available if No alarm action is selected in [Alarm 3 type]. • Setting range: 0 to 9999 seconds 	0 seconds



Character	Setting Item, Description, Setting Range	Factory Default
<i>AL4F</i>	Alarm 4 type <ul style="list-style-type: none"> Selects an Alarm 4 type. Note: If Alarm 4 type is changed, Alarm 4 value defaults to 0 (0.0). ---- : No alarm action H□□□: High limit alarm L□□□: Low limit alarm HL□□: High/Low limits alarm □□ d□: High/Low limit range alarm R4□□: Process high alarm rR4□: Process low alarm H□□□: High limit with standby alarm L□□□: Low limit with standby alarm HL□□: High/Low limits with standby alarm I HL□□: High/Low limits independent alarm I □□ d□: High/Low limit range independent alarm I HL□□: High/Low limits with standby independent alarm 	No alarm action
<i>R4EA</i>	Alarm 4 value 0 Enabled/Disabled <ul style="list-style-type: none"> Selects Alarm 4 action Enabled or Disabled when Alarm 4 value is 0 (zero). Not available if No alarm action is selected in [Alarm 4 type]. Invalidated for Process alarm no□□: Disabled YE4□: Enabled 	Disabled
<i>R4□□</i>	Alarm 4 value <ul style="list-style-type: none"> Sets Alarm 4 action point. Alarm 4 value matches Alarm 4 low limit alarm value in the following cases: When 'High/Low limits independent alarm', 'High/Low limit range independent alarm' or 'High/Low limits with standby independent alarm' is selected in [Alarm 4 type]. When Alarm, Loop break alarm and Heater burnout alarm are used together, they utilize common output terminals. Not available if No alarm action is selected in [Alarm 4 type]. Setting range: See (Table 5.2-1) on p.13. (For DC voltage and current inputs, the placement of the decimal point follows the selection.) 	0°C
<i>R4H□</i>	Alarm 4 high limit alarm value <ul style="list-style-type: none"> Sets Alarm 4 high limit alarm value. Available when 'High/Low limits independent alarm', 'High/Low limit range independent alarm' or 'High/Low limits with standby independent alarm' is selected in [Alarm 4 type]. Setting range: See (Table 5.2-1) on p.13. (For DC voltage and current inputs, the placement of the decimal point follows the selection) 	0°C
<i>R4Lā</i>	Alarm 4 Energized/De-energized <ul style="list-style-type: none"> Selects Alarm 4 action Energized/De-energized. (For details, see p.18.) Not available if No alarm action is selected in [Alarm 4 type]. noāL : Energized rĒB4 : De-energized 	Energized
<i>R4Hd</i>	Alarm 4 HOLD function <ul style="list-style-type: none"> Selects either Holding or Not holding in Alarm 4. When "Holding" is set, once alarm is activated, the alarm output remains ON until the power is turned off. Not available if No alarm action is selected in [Alarm 4 type]. noāĒ : Not holding Hold : Holding 	Not holding

Character	Setting Item, Description, Setting Range	Factory Default
<i>R4HY</i>	Alarm 4 hysteresis <ul style="list-style-type: none"> • Sets Alarm 4 hysteresis. • Not available if No alarm action is selected in [Alarm 4 type]. • Setting range: Thermocouple, RTD inputs: 0.1 to 100.0°C (°F) DC voltage, current inputs: 1 to 1000 (The placement of the decimal point follows the selection.) 	1.0°C
<i>R4DY</i>	Alarm 4 delay time <ul style="list-style-type: none"> • Sets Alarm 4 action delay time. When the setting time has elapsed after the input enters the alarm output range, the alarm is activated. • Not available if No alarm action is selected in [Alarm 4 type]. • Setting range: 0 to 9999 seconds 	0 seconds
<i>rEAL</i>	Remote/Local <ul style="list-style-type: none"> • Selects Remote (Remote operation) or Local (keypad operation) setting of the SV. • Available only when External setting input (EA option) is ordered. • <i>LoCL</i>: Local <i>rEAL</i>: Remote 	Local
<i>rF_b</i>	Remote bias <ul style="list-style-type: none"> • Sets the remote bias value. During remote action, the remote bias value is added to control desired value. • Available only when External setting input (EA option) is ordered. • Setting range: ±20% of input span 	0°C
<i>rFLH</i>	External setting input high limit <ul style="list-style-type: none"> • Sets External setting input high limit value. • Available only when External setting input (EA option) is ordered. • Setting range: External setting input low limit to Scaling high limit 	1370°C
<i>rFLl</i>	External setting input low limit <ul style="list-style-type: none"> • Sets External setting input low limit value. • Available only when External setting input (EA option) is ordered. • Setting range: Scaling low limit to External setting input high limit 	-200°C
<i>rR44</i>	SV Rise/Fall rate start type <ul style="list-style-type: none"> • When control output is turned from OFF to ON, or switched from Manual to Automatic control, SV start or PV start can be selected for SV rise rate or SV fall rate action. • When power is turned ON, PV start is adopted for SV Rise/Fall rate action, regardless of the selected type. • <i>4B4F</i>: SV start <i>PB4F</i>: PV start 	SV start
<i>rRFU</i>	SV rise rate <ul style="list-style-type: none"> • Sets SV rise rate (rising value for 1 minute). When the SV is adjusted, it approaches the new SV by the preset rate-of-change (°C/min., °F/min.). When the power is turned on, the control starts from the PV, and approaches the SV by the rate-of-change (°C/min., °F/min.). • Setting to 0 (zero) disables this function. • Setting range: 0 to 9999 °C/min. (°F/min.) (The placement of the decimal point follows the selection.) Thermocouple, RTD inputs: 0.0 to 999.9 °C/min. (°F/min.) DC voltage, current inputs: 0 to 9999/min. 	0 °C/minute

Character	Setting Item, Description, Setting Range	Factory Default
<i>rArd</i>	SV fall rate <ul style="list-style-type: none"> Sets SV fall rate (falling value for 1 minute). When the SV is adjusted, it approaches the new SV by the preset rate-of-change (°C/min., °F/min.). When the power is turned on, the control starts from the PV, and approaches the SV by the rate-of-change (°C/min., °F/min.). Setting to 0 (zero) disables this function. Setting range: 0 to 9999 °C/min. (°F/min.) (The placement of the decimal point follows the selection.) Thermocouple, RTD inputs: 0.0 to 999.9 °C/min. (°F/min.) DC voltage, current inputs: 0 to 9999/min. 	0 °C/minute
<i>PoUf</i>	Control output OUT1/EVT <ul style="list-style-type: none"> O1 terminals and EV terminals can be used for control output OUT1. If OUT1 is selected, O1 terminals will be used for control output OUT1 as follows. Control output OUT1: O1 terminals (③-④) Event output: EV terminals (⑧-⑨) If EVT is selected, EV terminals will be used for control output OUT1 as follows. Control output OUT1: EV terminals (⑧-⑨) Event output: O1 terminals (③-④) Select 'EVT' (EVT) if control output OUT1 is used as Open collector output. Not available for direct current output. <i>oUf</i>: OUT1 <i>EVT</i>: EVT 	OUT1
<i>Ho4L</i>	Heater burnout alarm output Enabled/Disabled <ul style="list-style-type: none"> Selects whether Event output is used for Heater burnout alarm output. If Heater burnout alarm, Loop break alarm and Alarm 1 to Alarm 4 output are set to "Enabled", they utilize common output terminals. Available only when Heater burnout alarm (W option) is ordered. <i>no</i>: Disabled <i>YE4</i>: Enabled 	Enabled
<i>LP4L</i>	Loop break alarm output Enabled/Disabled <ul style="list-style-type: none"> Selects whether Event output is used for Loop break alarm output. If Loop break alarm, Heater burnout alarm and Alarm 1 to Alarm 4 output are set to "Enabled", they utilize common output terminals. Not available if Heating/Cooling control (DC option) is ordered. <i>no</i>: Disabled <i>YE4</i>: Enabled 	Enabled
<i>A14L</i>	Alarm 1 output Enabled/Disabled <ul style="list-style-type: none"> Selects whether Event output is used for Alarm 1 output. If Loop break alarm, Heater burnout alarm, Alarm 2, Alarm 3 and Alarm 4 output are set to "Enabled", they utilize common output terminals. Not available if Heating/Cooling control (DC option) is ordered. <i>no</i>: Disabled <i>YE4</i>: Enabled 	Enabled
<i>A24L</i>	Alarm 2 output Enabled/Disabled <ul style="list-style-type: none"> Selects whether Event output is used for Alarm 2 output. If Loop break alarm, Heater burnout alarm, Alarm 1, Alarm 3 and Alarm 4 output are set to "Enabled", they utilize common output terminals. Not available if Heating/Cooling control (DC option) is ordered. <i>no</i>: Disabled <i>YE4</i>: Enabled 	Disabled
<i>A34L</i>	Alarm 3 output Enabled/Disabled <ul style="list-style-type: none"> Selects whether Event output is used for Alarm 3 output. If Loop break alarm, Heater burnout alarm, Alarm 1, Alarm 2 and Alarm 4 output are set to "Enabled", they utilize common output terminals. Not available if Heating/Cooling control (DC option) is ordered. <i>no</i>: Disabled <i>YE4</i>: Enabled 	Disabled

Character	Setting Item, Description, Setting Range	Factory Default
<i>P44L</i>	Alarm 4 output Enabled/Disabled <ul style="list-style-type: none"> • Selects whether Event output is used for Alarm 4 output. If Loop break alarm, Heater burnout alarm, Alarm 1, Alarm 2 and Alarm 3 output are set to “Enabled”, they utilize common output terminals. • Not available if Heating/Cooling control (DC option) is ordered. • <i>no</i>□□: Disabled <i>YE4</i>□□: Enabled 	Disabled
<i>P4F1</i>	OUT1 MV Preset value <ul style="list-style-type: none"> • Sets OUT1 MV preset value when Preset output 1 or 2 is selected in [Event input DI allocation]. Function 1: Outputs OUT1 MV preset value when Event input DI is closed and sensor is burnt out. Function 2: Outputs OUT1 MV preset value when Event input DI is closed. • Available only when Set value memory external selection (EI option) is ordered. • 0.0% or 100.0% for ON/OFF control • Setting range: OUT1 low limit to OUT1 high limit 	0.0%
<i>P4F2</i>	OUT2 MV Preset value <ul style="list-style-type: none"> • Sets OUT2 MV preset value when Preset output 1 or 2 is selected in [Event input DI allocation]. Function 1: Outputs OUT2 MV preset value when Event input DI is closed and sensor is burnt out. Function 2: Outputs OUT2 MV preset value when Event input DI is closed. • Available when Set value memory external selection (EI option) or Heating/Cooling control (DC option) is ordered. 0.0% or 100.0% for ON/OFF control action • Setting range: OUT2 low limit to OUT2 high limit 	0.0%
<i>̄ARRU</i>	SUB-MODE key function <ul style="list-style-type: none"> • Selects a function of the SUB-MODE key from the following: Control output OFF, Auto/Manual control, Alarm HOLD cancel • <i>OFF</i>□□: Control output OFF <i>̄ARRU</i>: Auto/Manual control <i>ALOF</i>: Alarm HOLD cancel 	Control output OFF
<i>̄ARR4</i>	Auto/Manual control after power ON <ul style="list-style-type: none"> • When the power is turned ON, Automatic control or Manual control can be selected for starting control. • Available only when ‘Auto/Manual control’ is selected in [SUB-MODE key function]. • <i>AUF</i>□: Automatic control <i>̄ARRU</i>: Manual control 	Automatic control

5.6 Output MV (manipulated variable) Indication

Description
Output MV (manipulated variable) indication Press the  key for approx. 3 seconds in PV/SV Display Mode. Keep pressing the  key until the output manipulated variable appears, though the main setting mode appears during the process. The output MV is indicated on the SV Display, and the 1st dot from the right flashes in 500 ms cycles on the SV Display. If the  key is pressed again, the instrument reverts to PV/SV Display Mode.



6. Simplified Converter Function

Caution

- The converter function is selectable only for the Direct current output type.
- When using this controller as a converter, take 1 second into consideration since input/output response time is approx. 1 second.
- When switching from converter to controller function, the control parameters and values set by converter function are retained even if the function is switched to controller function. So, after switching to the controller function, correct the converter parameters to the controller parameters.

The converter function of this instrument converts each input (thermocouple, RTD, DC voltage and direct current inputs) value to “4 to 20 mA DC”, using the control parameters of the controller, and outputs it.

When this instrument is used as a converter, follow steps (1) to (7) described below.
After steps (1) to (7) are finished, this instrument can be used as a converter.

- (1) Wire this unit (Power supply, Input and Output).
- (2) Turn the power supply of this unit ON.
- (3) Enter ‘Auxiliary function setting mode 2’ by pressing the  and  key (for approx. 3 seconds).
- (4) Select a sensor type in [Input type] (4E n4).
- (5) Set the high limit of the value to be converted in [Scaling high limit] (4F L H).
- (6) Set the low limit of the value to be converted in [Scaling low limit] (4F L L).
- (7) Select Converter (c n H F) in [Controller/Converter] (F U n c).

- To activate the alarm action by Converter function, set the alarm type to Process alarm.

If ‘Converter’ is selected in [Controller/Converter] in Auxiliary function setting mode 2, parameters below are automatically set. (Table 6-1)

(Table 6-1)

Setting Item	Setting Value
SV1	Scaling low limit
SV2	Scaling low limit
Integral time	0
Derivative time	0
OUT1 proportional band	100.0%
OUT2 proportional band	1.0
Manual reset	0.0
Alarm 1 value 0 Enabled/Disabled	Disabled
Alarm 1 value	0
Alarm 1 high limit alarm value	0
Alarm 2 value 0 Enabled/Disabled	Disabled
Alarm 2 value	0
Alarm 2 high limit alarm value	0
Alarm 3 value 0 Enabled/Disabled	Disabled
Alarm 3 value	0
Alarm 3 high limit alarm value	0
Alarm 4 value 0 Enabled/Disabled	Disabled
Alarm 4 value	0
Alarm 4 high limit alarm value	0
Loop break alarm time	0
Loop break alarm band	0
Direct/Reverse action	Direct action
Event input DI allocation	000

Setting Item	Setting Value
Remote/Local (EA-option)	Local
SV rise rate	0
SV fall rate	0
OUT1 high limit	100
OUT1 low limit	0
Alarm 1 to Alarm 4 types	No alarm action
Alarm 1 hysteresis	1.0
Alarm 1 delay time	0
Alarm 1 Energized/De-energized	Energized
Alarm 2 hysteresis	1.0
Alarm 2 delay time	0
Alarm 2 Energized/De-energized	Energized
Alarm 3 hysteresis	1.0
Alarm 3 delay time	0
Alarm 3 Energized/De-energized	Energized
Alarm 4 hysteresis	1.0
Alarm 4 delay time	0
Alarm 4 Energized/De-energized	Energized

6.1 Fine Adjustment of Converter Output (4 to 20 mA DC)









Outputs “4 to 20 mA DC” corresponding to the input from scaling low limit to high limit value.
Fine adjustment rate is 1/1000 of the scaling span.

Fine adjustment method









Be sure to adjust the zero side first. Then adjust the span side.

Adjust zero in [Manual reset (r L E F)], and adjust span in [Proportional band (P□□□)].

(1) Zero adjustment

- ① Enter the value so that the PV Display can indicate the same value as the scaling low limit value.
- ② Press the  and  key (in that order) together. The unit proceeds to Sub setting mode.
- ③ Press the  key several times until [Manual reset (r L E F)] appears.
- ④ Adjust the converter output value so that it can become 4 mA DC by increasing and decreasing the value with the  and  keys.
Pressing the  key decreases the value, and the  key increases it.
- ⑤ Revert to the PV/SV Display Mode by pressing the  key several times.

(2) Span adjustment

- ① Enter the value so that the PV Display can indicate the same value as the scaling high limit value.
- ② Press the  and  key (in that order) together. The unit proceeds to Sub setting mode.
- ③ Proceed to [Proportional band (P□□□)] by pressing the  key.
- ④ Adjust the converter output value so that it can become 20 mA DC by increasing and decreasing the value with the  and  keys.
Pressing the  key decreases the value, and the  key increases it.
- ⑤ Revert to the PV/SV Display Mode by pressing the  key several times.

(3) Repeat steps (1) and (2) several times.

6.2 Converter Setting Example

[Other Inputs except 4 to 20 mA DC]

Input, output conditions

Input: 6 to 14 mA DC (Indication: 30.0 to 130.0)

Output: 4 to 20 mA DC

Setting method

(1) Calculating Scaling high and low limit value of 4 to 20 mA DC

Indication value per mA DC: $(130.0 - 30.0) \div (14 - 6) = 100 \div 8 = 12.5$

Scaling high limit value: $130.0 + (20 - 14) \times 12.5 = 205.0$

Scaling low limit value: $30.0 - (6 - 4) \times 12.5 = 5.0$

(2) Calculating OUT proportional band of 6 to 14 mA DC

OUT proportional band (P) = $\{(14 - 6) \div (20 - 4)\} \times 100 = 0.5 \times 100 = 50(\%)$

(3) Calculating SV so that output can become 4 mA DC from 6 mA DC input (Parallel shift setting)

SV = $\{(6 - 4) \times 12.5\} + 5.0$ (Scaling low limit) = 30.0

Input, output and indication

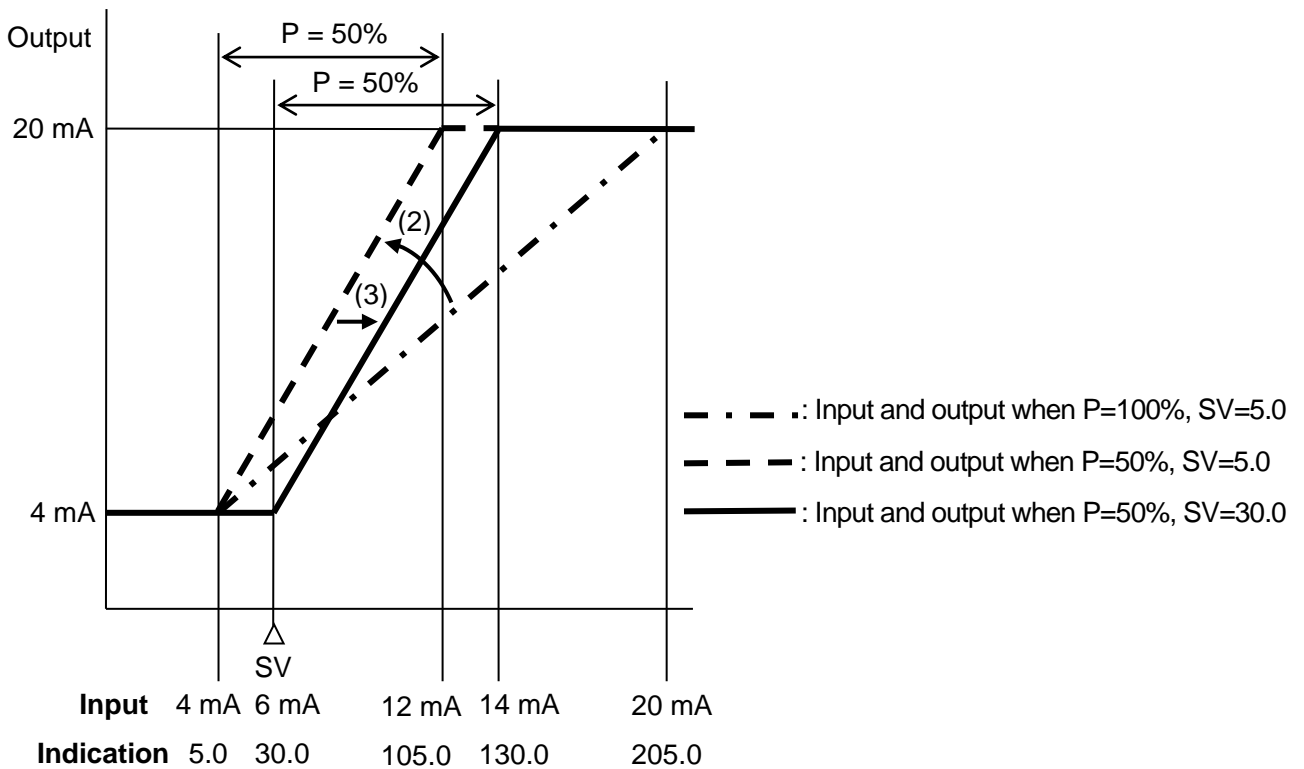

(Fig. 6.2-1)

7. Operation

After the unit is mounted within the control panel (DIN rail) and wiring is completed, operate the unit following the procedure below.

(1) Turn the power supply to the DCL-33A ON.

For approx. 3 seconds after power is turned on, sensor input characters and temperature unit are indicated on the PV Display, and the input range high limit value is indicated on the SV Display.

See (Table 5-1) on p.11. During this time, all outputs and LED indicators are in OFF status.

(If any other value is set in [Scaling high limit], the SV Display indicates it.)

After that, the PV Display indicates PV (process variable), and the SV Display indicates SV (desired value).

(2) Enter each set value.

Enter each set value, referring to "5. Setup".

(3) Turn the load circuit power ON.

Control action starts so as to keep the control target at the SV (desired value).

SUB-MODE Key Function

The SUB-MODE key function differs depending on the selection in [SUB-MODE key function].

• If 'Control output OFF' is selected:

The control action and output of an instrument (or instruments) can be turned OFF without turning OFF their power supplies using this function.

If the control output OFF function is enabled, the PV Display will indicate $\square FF \square$, turning all outputs OFF.

To enable the control output OFF function in PV/SV Display Mode, press the SUB-MODE key for approximately 1 second.

To enable the control output OFF function in setting mode, press the SUB-MODE key for approximately 3 seconds.

To cancel the control output OFF function, press the SUB-MODE key for approximately 1 second again. The unit will return to PV/SV Display Mode.

• If 'Auto/Manual control' is selected:

Auto/Manual control can be switched.

Each time the SUB-MODE key is pressed for approximately 1 second in PV/SV Display Mode, Automatic or Manual control can be switched.

• If 'Alarm HOLD cancel' is selected:

Alarm Hold can be cancelled for the Alarm with Hold function.

To enable the Alarm HOLD cancel function in PV/SV Display Mode, press the SUB-MODE key for approximately 1 second.

To enable the Alarm HOLD cancel function in setting mode, press the SUB-MODE key for approximately 3 seconds.

Event Input

Event Input DI action has priority over key operation.

Set value memory external selection (EI option)

By closing or opening the Event Input DI contact, SV1 and SV2 can be selected.

Depending on the selection in [Event input DI allocation], the following differences result in:

If 001 (Set value memory) is selected in [Event input DI allocation]:

Event input DI Open: SV1

Event input DI Closed: SV2

If 008 (Set value memory) is selected in [Event input DI allocation]:

Event input DI Open: SV2

Event input DI Closed: SV1

8. Action Explanations

8.1 OUT1 Action

	Heating (Reverse) action	Cooling (Direct) action
Control action		
Relay contact output		
Non-contact voltage output		
Direct current output		
Indicator (OUT) Green		

: Turns ON or OFF.

8.2 OUT1 ON/OFF Control Action

	Heating (Reverse) action	Cooling (Direct) action
Control action		
Relay contact output		
Non-contact voltage output		
Direct current output		
Indicator (OUT) Green		

: Turns ON or OFF.

8.3 Heater Burnout Alarm Action

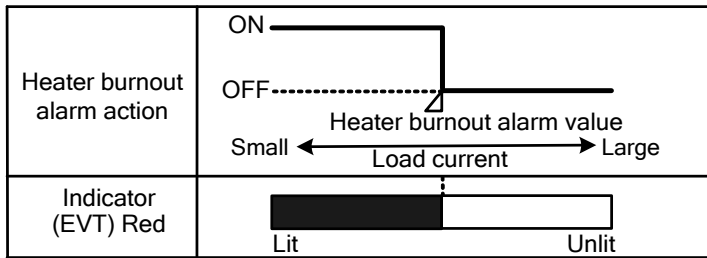

: Event output EV terminals 8 and 9 are ON.

: Event output EV terminals 8 and 9 are OFF.

The Event output EVT indicator lights up when Event output EV terminals 8 and 9 are ON, and turns off when they are OFF.

8.4 Alarm Action

	High limit alarm	Low limit alarm
Alarm action		
Alarm output	+side -side	+side -side
	High/Low limits alarm	High/Low limits independent alarm
Alarm action		
Alarm output		
	High/Low limit range alarm	High/Low limit range independent alarm
Alarm action		
Alarm output		

	Process high alarm	Process low alarm
Alarm action		
Alarm output		
	High limit with standby alarm	Low limit with standby alarm
Alarm action		
Alarm output	+side: -side:	+side: -side:
	High/Low limits with standby alarm	High/Low limits with standby independent alarm
Alarm action		
Alarm output		

- : Event output EV terminals 8 and 9 are ON.
- : Event output EV terminals 8 and 9 are ON or OFF.
- : Event output EV terminals 8 and 9 are OFF.
- : Alarm output is in Standby.

The Event output EVT indicator lights up when Event output EV terminals 8 and 9 are ON, and turns off when they are OFF.

8.5 OUT2 (Heating/Cooling Control) Action

Control action			
Relay contact output	<p>Cycle action is performed according to deviation.</p>		
Non-contact voltage output	<p>Cycle action is performed according to deviation.</p>		
Direct current output	<p>Changes continuously according to deviation.</p>		
Open collector output	<p>Cycle action is performed according to deviation.</p>		
Indicator (OUT) Green	<p>Lit Unlit</p>		
Indicator (EVT) Red	<p>Unlit Lit</p>		

: Turns ON (lit) or OFF (unlit).

———— : Represents Heating control action.

----- : Represents Cooling control action.

8.6 OUT2 Action (When Setting Overlap Band)

Control action	
Relay contact output	<p style="text-align: center;">Cycle action is performed according to deviation.</p>
Non-contact voltage output	<p style="text-align: center;">Cycle action is performed according to deviation.</p>
Direct current output	<p style="text-align: center;">Changes continuously according to deviation.</p>
Open collector output	<p style="text-align: center;">Cycle action is performed according to deviation.</p>
Indicator (OUT) Green	
Indicator (EVT) Red	

: Turns ON (lit) or OFF (unlit).

———— : Represents Heating control action.

----- : Represents Cooling control action.

8.7 OUT2 Action (When Setting Dead Band)

Control action	
Relay contact output	<p>Cycle action is performed according to deviation.</p>
Non-contact voltage output	<p>Cycle action is performed according to deviation.</p>
Direct current output	<p>Changes continuously according to deviation.</p>
Open collector output	<p>Cycle action is performed according to deviation.</p>
Indicator (OUT) Green	
Indicator (EVT) Red	

: Turns ON (lit) or OFF (unlit).

———— : Represents Heating control action.

----- : Represents Cooling control action.

9. AT (Auto-tuning)

In order to decide each value of P, I, D and ARW automatically, the auto-tuning process should be made to fluctuate to obtain an optimal value.

One of 3 types of fluctuation below is automatically selected.

For DC input, the AT process will fluctuate around the SV for conditions of (A), (B) and (C).

Sometimes the auto-tuning process will not fluctuate if auto-tuning is performed at or near room temperature. Therefore auto-tuning might not finish normally.

(A) In the case of a large difference between the SV and processing temperature as the temperature is rising

When AT bias is set to 20°C, the AT process will fluctuate at temperatures 20°C lower than the SV.

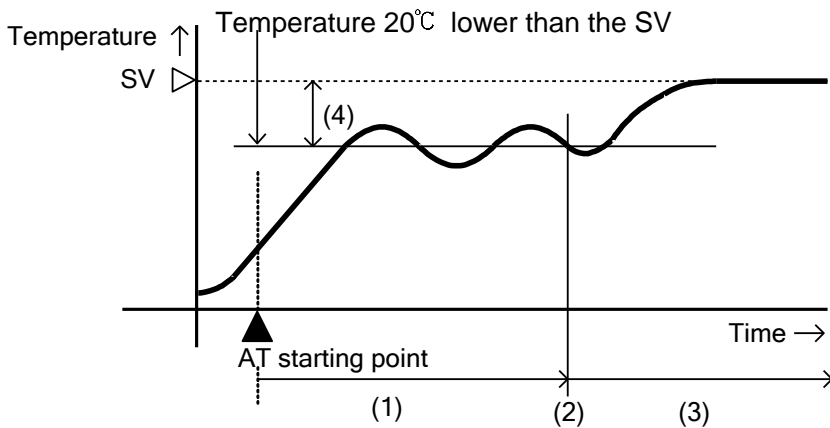

- (1) Calculates PID constant.
- (2) PID constant calculated
- (3) Controlled by the PID constant set by auto-tuning.
- (4) AT bias value

(B) When control is stable

The AT process will fluctuate around the SV.

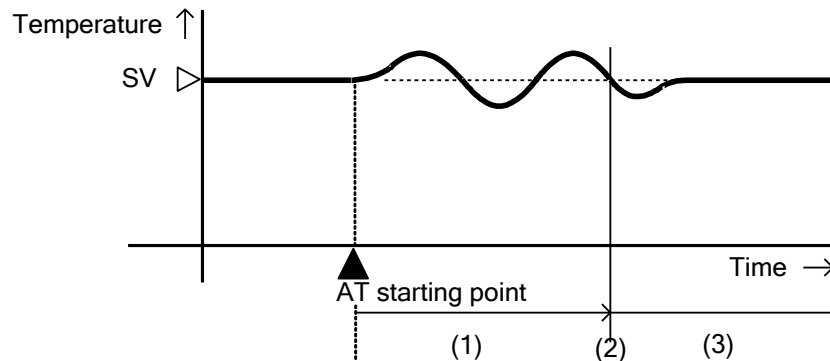

- (1) Calculates PID constant.
- (2) PID constant calculated
- (3) Controlled by the PID constant set by auto-tuning.

(C) In the case of a large difference between the SV and processing temperature as the temperature is falling

When AT bias is set to 20°C, the AT process will fluctuate at temperatures 20°C higher than the SV.

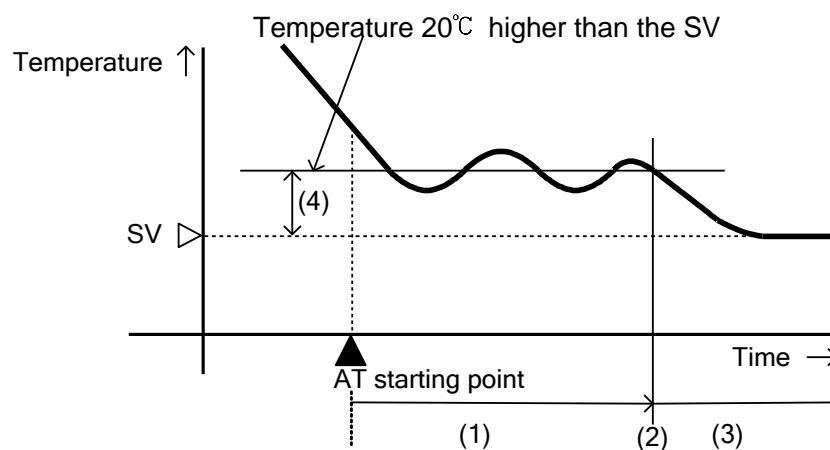

- (1) Calculates PID constant.
- (2) PID constant calculated
- (3) Controlled by the PID constant set by auto-tuning.
- (4) AT bias value

10. Specifications

10.1 Standard Specifications

Model: DIN rail mounted indicating controller

Mounting: DIN rail

Setting: Input system using membrane sheet key

Display:

PV Display: Red LED 4 digits, character size 7.4 x 4.0 mm (H x W)

SV Display: Green LED 4 digits, character size 7.4 x 4.0 mm (H x W)

Input:

Thermocouple: K, J, R, S, B, E, T, N, PL-II, C (W/Re5-26) External resistance: 100 Ω max.
However, for thermocouple B, external resistance: 40 Ω max.

RTD: Pt100, JPt100, 3-wire type

Allowable input lead wire resistance (10 Ω max. per wire)

Direct current: 0 to 20 mA DC, 4 to 20 mA DC, input impedance 50 Ω

If direct current input (Externally mounted 50 Ω shunt resistor) is designated, connect a 50 Ω shunt resistor (sold separately) between input terminals.

Allowable input current: 50 mA max.

DC voltage:

	0 to 1 V DC	0 to 5 V DC, 1 to 5 V DC, 0 to 10 V DC
Input impedance	1 MΩ minimum	100 kΩ minimum
Allowable input voltage	5 V max.	15 V max.
Allowable signal source resistance	2 kΩ max.	100 Ω max.

Indication performance:

Base accuracy (at ambient temperature 23°C, for a single unit mounting):

Thermocouple: Within ±0.2% of input span ±1 digit, or within ±2°C (4°F), whichever is greater

R, S inputs, 0 to 200°C (32 to 392°F): Within ±6°C (12°F)

B input, 0 to 300°C (32 to 572°F): Accuracy is not guaranteed.

K, J, E, T, N input, less than 0°C (32°F):

Within ±0.4% of input span ±1 digit, or ±4°C (8°F), whichever is greater

RTD: Within ±0.1% of input span ±1 digit, or within ±1°C (2°F), whichever is greater

DC voltage: Within ±0.2% of input span ±1 digit

Direct current: Within ±0.2% of input span ±1 digit

Input sampling period: 125 ms

Control performance: Same as setting accuracy and base accuracy

Control action:

- PID control [with auto-tuning (AT) function]
- PI control: When derivative time is set to 0
- PD control (with manual reset function): When integral time is set to 0
- P control (with manual reset function): When derivative and integral time are set to 0
- ON/OFF control: When OUT1 proportional band is set to 0.0

OUT1 proportional band: 0.0 to 110.0% (ON/OFF control when set to 0.0)

Integral time: 0 to 3600 seconds (Disabled when set to 0)

Derivative time: 0 to 1800 seconds (Disabled when set to 0)

OUT1 proportional cycle: 1 to 120 seconds

ARW: 0 to 100%

Manual reset: ±Proportional band converted value

OUT1 high, OUT1 low limit: 0 to 100% (Direct current output type: -5 to 105%)
(Not available for ON/OFF control)

OUT1 ON/OFF hysteresis: Thermocouple, RTD inputs: 0.1 to 100.0°C (°F)

DC voltage, current inputs: 1 to 1000 (The placement of the decimal point follows the selection.)

Control output (OUT):

- Relay contact: 1a, Control capacity: 3 A 250 V AC (Resistive load)

1 A 250 V AC (Inductive load $\cos\phi = 0.4$)

Electrical life: 100,000 cycles

- Non-contact voltage (for SSR drive): 12 V DC ±15% Max. 40 mA DC (Short circuit protected)

- Direct current: 4 to 20 mA DC, Load resistance: Max. 550 Ω

Output accuracy: Within ±0.3% of the output span

Resolution: 12000

Event output:

• **Alarm output**

[Alarm, Loop break alarm and Heater burnout alarm (W option) utilize common output terminals.]

The alarm action point is set by \pm deviation from the SV (excluding Process alarm), and when input goes outside the range, alarm output is turned ON or OFF (High/Low limit range alarm). When De-energized is selected in [Alarm Energized/De-energized], alarm output is activated conversely.

Setting accuracy: Same as base accuracy

Action: ON/OFF action

Hysteresis: Thermocouple, RTD inputs: 0.1 to 100.0°C (°F)
DC voltage, current inputs: 1 to 1000 (The placement of the decimal point follows the selection.)

Output: Open collector, Control capacity: 0.1 A 24 V DC

Alarm type: One alarm action can be selected from below by front keypad operation:
High limit, Low limit, High/Low limits, High/Low limits independent, High/Low limit range, High/Low limit range independent, Process high, Process low, High limit with standby, Low limit with standby, High/Low limits with standby, High/Low limits with standby independent alarm, and No alarm action

The above 12 alarm types and No alarm action can be selected.

Energized/De-energized: Alarm (EVT) output Energized/De-energized can be selected.

	Energized	De-energized
EVT indicator (Red)	Lights up	Lights up
Event output	ON	OFF

Alarm HOLD function: Once the alarm is activated, alarm output is maintained until the power is turned off.

• **Loop break alarm output**

[Loop break alarm, Alarm and Heater burnout alarm (W option) utilize common output terminals.]

Detects heater burnout, sensor burnout and actuator trouble.

Setting range: Loop break alarm time: 0 to 200 minutes

Loop break alarm band:

Thermocouple, RTD inputs : 0 to 150°C (°F) or 0.0 to 150.0°C (°F)
DC voltage, current inputs: 0 to 1500 (The placement of the decimal point follows the selection.)

Output: Open collector, Control capacity: 0.1 A 24 V DC

Converter function: See “6. Simplified Converter Function”.

Attached function:

[Set value lock]

[Sensor correction]

[Power failure countermeasure]

The setting data is backed up in non-volatile IC memory.

[Self diagnosis]

The CPU is monitored by a watchdog timer, and if an abnormal status occurs, the controller is switched to warm-up status, turning all outputs off.

[Automatic cold junction temperature compensation] (Only thermocouple input)

Detects the temperature at the connection terminal (between the thermocouple and the instrument), and maintains it at the same status as if the reference junction location temperature were at 0°C (32°F).

[Burnout]

When the thermocouple or RTD input is burnt out, OUT is turned OFF (for direct current output, OUT low limit value), and the PV Display flashes [- - -].

[Input error indication]

Output status when input errors occur (*1)	Contents and Indication	Output status					
		Controller/Converter					
		Controller				Converter	
		OUT1		OUT2		OUT1	
		Direct action	Reverse action	Direct	Reverse	Direct	Reverse
ON []	[- - - -] flashes.	ON (20 mA) or OUT1 high limit value (*2)	OFF (4 mA) or OUT1 low limit value	OUT2 low limit value		20 mA or OUT1 high limit value	4 mA or OUT1 low limit value
OFF []		OFF (4 mA) or OUT1 low limit value					
ON []	[- - - -] flashes.	OFF (4 mA) or OUT1 low limit value	ON (20 mA) or OUT1 high limit value (*2)	OUT2 low limit value		4 mA or OUT1 low limit value	20 mA or OUT1 high limit value
OFF []			OFF(4 mA) or OUT1 low limit value				

(*1) [Output status when input errors occur] can be used only for controllers using direct current and voltage inputs, and direct current output. If OUT is not Direct current output, the output status will be the same as when OFF [] is selected in [Output status when input errors occur]. For manual control, the preset MV is output.

(*2) Outputs a value between OFF (4 mA) and ON (20 mA) or between OUT1 low limit value and OUT1 high limit value, depending on deviation.

Thermocouple, RTD inputs

Input	Input range	Indication range	Control range
K, T	-199.9 to 400.0°C	-199.9 to 450.0°C	-205.0 to 450.0°C
	-199.9 to 750.0°F	-199.9 to 850.0°F	-209.0 to 850.0°F
Pt100	-199.9 to 850.0°C	-199.9 to 900.0°C	-210.0 to 900.0°C
	-200 to 850°C	-210 to 900°C	-210 to 900°C
	-199.9 to 999.9°F	-199.9 to 999.9°F	-211.0 to 1099.9°F
	-300 to 1500°F	-318 to 1600°F	-318 to 1600°F
JPt100	-199.9 to 500.0°C	-199.9 to 550.0°C	-206.0 to 550.0°C
	-200 to 500°C	-207 to 550°C	-207 to 550°C
	-199.9 to 900.0°F	-199.9 to 999.9°F	-211.0 to 999.9°F
	-300 to 900°F	-312 to 1000°F	-312 to 1000°F

Indication range and Control range for thermocouple inputs except above:

[Input range low limit value - 50°C (100°F)] to [Input range high limit value + 50°C (100°F)]

DC input

Indication range: [Scaling low limit value - Scaling span x 1%] to [Scaling high limit value + Scaling span x 10%]

However, if the input value is out of the range -1999 to 9999, the PV Display flashes [- - - -] or [- - - -].

Control range: [Scaling low limit value - Scaling span x 1%] to [Scaling high limit value + Scaling span x 10%]

DC input disconnection

When DC input is disconnected, the PV Display flashes [- - - -] for 1 to 5 V DC and 4 to 20 mA DC inputs, and [- - - -] for 0 to 1 V DC input.

For 0 to 5 V DC, 0 to 10 V DC and 0 to 20 mA DC inputs, the PV Display indicates the value corresponding with 0 V or 0 mA input.

Insulation/Dielectric strength: Circuit insulation configuration

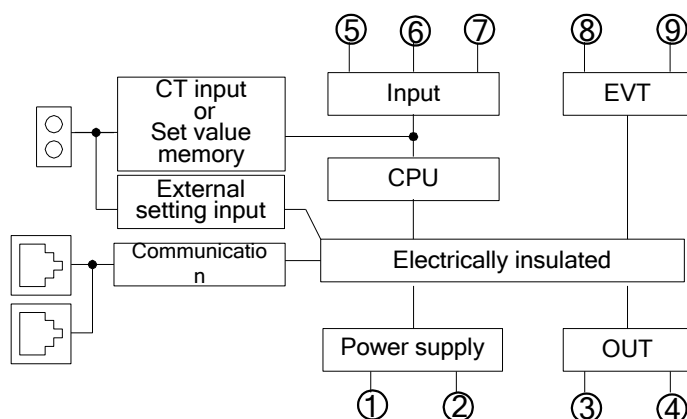

Insulation resistance: 10 M Ω minimum, at 500 V DC

Dielectric strength: 1.5 kV AC for 1 minute

Power supply: 100 to 240 V AC 50/60 Hz, 24 V AC/DC 50/60 Hz

Allowable voltage fluctuation range: 100 to 240 V AC: 85 to 264 V AC, 24 V AC/DC: 20 to 28 V AC/DC

Power consumption: 100 to 240 V AC: Approx. 5 VA max.

24 V AC: Approx. 4 VA max.

24 V DC: Approx. 4 W max.

Ambient temperature: 0 to 50°C (32 to 122°F)

Ambient humidity: 35 to 85 %RH (non-condensing)

Altitude: 2,000 m or less

Weight: Approx. 100 g

External dimension: 22.5 x 75 x 100 mm (W x H x D)

Material: Flame-resistant resin (Case)

Color: Black (Case)

Accessories included:

Instruction manual excerpt: 1 copy

When Heater burnout alarm output (W option) is ordered: Connector harness W 3 m: 1 length

When Heater burnout alarm output (W option) is ordered:

For rated current 5A, 10A, 20A: CT (CTL-6-S-H): 1 piece

For rated current 50A: CT (CTL-12-S36-10L1U): 1 piece

When Set value memory external selection (EI option) is ordered:

Connector harness AOJ 3 m: 1 length

When External setting input (EA option) is ordered: Connector harness AOJ 3 m: 1 length

Accessories sold separately: 50 Ω shunt resistor for direct current input

10.2 Optional Specifications

Heater burnout alarm output (W option)

Watches the heater current with CT (Current transformer), and detects the burnout.

This alarm is also activated when sensor is burnt out, or when indication is overscale or underscale.

Heater burnout alarm, Alarm and Loop break alarm utilize common output terminals.

This option cannot be used for direct current output type.

Rating: 5 A [W (5 A)], 10 A [W (10 A)], 20 A [W (20 A)], 50 A [W (50 A)] (Must be specified)

Setting range: 5 A [W (5 A)]: 0.0 to 5.0 A (OFF when set to 0.0)

10 A [W (10 A)]: 0.0 to 10.0 A (OFF when set to 0.0)

20 A [W (20 A)]: 0.0 to 20.0 A (OFF when set to 0.0)

50 A [W (50 A)]: 0.0 to 50.0 A (OFF when set to 0.0)

Setting accuracy: $\pm 5\%$ of the heater rated current

Action point: Setting value

Action: ON/OFF action

Output: Open collector, Control capacity: 0.1 A 24 V DC

Serial communication (C5 option)

The following operations are performed from an external computer.

- (1) Reading and writing of the SV, PID and other various set values
- (2) Reading of the PV and action status
- (3) Function change

Cable length : Max. 1.2 km, Cable resistance: Within 50 Ω (Terminators are not necessary, but if used, use 120 Ω minimum on both sides.)

Communication line: EIA RS-485

Communication method: Half-duplex communication

Communication speed: 2400/4800/9600/19200/38400 bps (Default: 9600bps)(Selectable by keypad)

Synchronization method: Start-stop synchronization

Parity: Even/Odd/No parity (Default: Even) (Selectable by keypad)

Stop bit: 1, 2 (Default: 1)(Selectable by keypad)

Communication protocol: Shinko protocol/MODBUS ASCII/MODBUS RTU (Selectable by keypad)
(Default: Shinko protocol)

Data format:

Communication protocol	Shinko protocol	MODBUS ASCII	MODBUS RTU
Start bit	1	1	1
Data bit	7	7	8
Parity	Even	Even (No parity, Odd) Selectable	No parity (Even, Odd) Selectable
Stop bit	1	1 (2) Selectable	1 (2) Selectable

The data bits are automatically switched according to the selected communication protocol.

Error correction: Command request repeat system

Error detection: Parity check, checksum (Shinko protocol), LRC (MODBUS ASCII), CRC-16 (MODBUS RTU)

Digital external setting:

Step SV can be received from the connected Shinko programmable controllers PCA1 or PCB1.

(‘SV digital transmission’ should be selected in [Communication protocol] on the PCA1 or PCB1.)

When data from the programmable controller is larger than SV high limit or smaller than SV low limit, DCL-33A ignores the value and controls with the previous value. The control desired value adds SVTC bias value to the value received by the SVTC command.

Heating/Cooling control output (DC option)

OUT2 proportional band: 0.0 to 10.0 times OUT1 proportional band (ON/OFF control when set to 0.0)

Integral time: Same as that of OUT1

Derivative time: Same as that of OUT1

OUT2 proportional cycle: 1 to 120 seconds

Overlap/Dead band: Thermocouple, RTD inputs: -100.0 to 100.0°C ($^{\circ}\text{F}$)

DC voltage, current inputs: -1000 to 1000 (The placement of the decimal point follows the selection)

OUT2 ON/OFF hysteresis: Thermocouple, RTD inputs: 0.1 to 100.0°C ($^{\circ}\text{F}$)

DC voltage, current inputs: 1 to 1000 (The placement of the decimal point follows the selection.)

OUT2 high limit, OUT2 low limit: 0 to 100%

OUT2 cooling method: Air cooling (Linear characteristics), Oil cooling (1.5th power of the linear characteristics), Water cooling (2nd power of the linear characteristics)

Output: Open collector, control capacity: 0.1 A 24 V DC

Set value memory external selection (EI option)

Switches SV1 and SV2 by external contact.

If 001 is selected in [Event input DI allocation]:

DI input Open: SV1

DI input Closed: SV2

If 008 is selected in [Event input DI allocation]:

DI input Open: SV2

DI input Closed: SV1

Circuit current when closed: Approx. 2 mA

External setting input (EA option)

If 'Remote' is selected in [Remote/Local], external analog signal will become SV.

Remote bias value is added to the control desired value.

Setting signal: Direct current 4 to 20 mA

Allowable input: 50 mA DC max.

Input impedance: 50 Ω max.

Input sampling period: 125 msec

Option combination (●: Can be used together.)

Option Code	W	DC	C5	EA	EI
W		●	●	-	-
DC	●		●	●	●
C5	●	●		●	●
EA	-	●	●		-
EI	-	●	●	-	

W, EA and EI options cannot be used together.

11. Troubleshooting





If any malfunctions occur, refer to the following after checking that power is being supplied to the controller.

11.1 Indication

Problem	Possible Cause	Solution
<p>[- - - -] is flashing on the PV Display.</p>	<p>Burnout of thermocouple, RTD or disconnection of DC voltage (0 to 1 V DC)</p>	<p>Replace each sensor. How to check whether the sensor is burnt out [Thermocouple] If the input terminals of the instrument are shorted, and if a value around room temperature is indicated, the instrument is likely to be operating normally, however, the sensor may be burnt out. [RTD] If approx. 100 Ω resistance is connected to the input terminals between A-B of the instrument and between B-B is shorted, and if a value around 0°C (32°F) is indicated, the instrument is likely to be operating normally, however, the sensor may be burnt out. [DC voltage (0 to 1 V DC)] If the input terminals of the instrument are shorted, and if a scaling low limit value is indicated, the instrument is likely to be operating normally, however, the signal wire may be disconnected.</p>
	<p>Check whether the input terminals of thermocouple, RTD or DC voltage (0 to 1 V DC) are securely mounted to the instrument input terminals.</p>	<p>Connect the sensor terminals to the instrument terminals securely.</p>
<p>[- - - -] is flashing on the PV Display.</p>	<p>The input signal wire for DC voltage (1 to 5 V DC) or direct current (4 to 20 mA DC) may be disconnected.</p>	<p>How to check whether the input signal wire is disconnected [DC voltage (1 to 5 V DC)] If the input to the input terminals of this controller is 1 V DC, and if a scaling low limit value is indicated, the controller is likely to be operating normally, however, the signal wire may be disconnected. [Direct current (4 to 20 mA DC)] If the input to the input terminals of this controller is 4 mA DC, and if a scaling low limit value is indicated, the controller is likely to be operating normally, however, the signal wire may be disconnected.</p>
	<p>Check whether the input signal wire for DC voltage (1 to 5 V DC) or Direct current (4 to 20 mA DC) is securely connected to the controller input terminals.</p>	<p>Connect the signal wire to the controller input terminals securely.</p>
	<p>Check whether the polarity of thermocouple or compensating lead wire is correct. Check whether codes (A, B, B) of the RTD match with the controller input terminals</p>	<p>Wire them correctly.</p>

Problem	Possible Cause	Solution
The value set in [Scaling low limit] remains on the PV Display.	Check whether the input signal wire for DC voltage (0 to 5 V DC, 0 to 10 V DC) or direct current (0 to 20 mA DC) is disconnected.	<p>How to check whether the input signal wire is disconnected [DC voltage (0 to 5 V DC, 0 to 10 V DC)]</p> <p>If the input to the input terminal of this controller is 1 V DC, and if a value (converted value from Scaling high, low limit setting) corresponding to 1 V DC is indicated, the controller is likely to be operating normally, however, the signal wire may be disconnected.</p> <p>[Direct current (0 to 20 mA DC)]</p> <p>If the input to the input terminal of this controller is 4 mA DC, and if a value (converted value from Scaling high, low limit setting) corresponding to 4 mA DC is indicated, the controller is likely to be operating normally, however, the signal wire may be disconnected.</p>
	Check whether the input signal wire for DC voltage (0 to 5 V DC, 0 to 10 V DC) or direct current (0 to 20 mA DC) is securely connected to the controller input terminals.	Connect the signal wire to the controller input terminals securely.
The indication of the PV Display is irregular or unstable.	Check whether the sensor input or temperature unit (°C, °F) is correct.	Set the sensor input and the temperature unit (°C, °F) correctly.
	Sensor correction value is not suitable.	Set it to a suitable value.
	Check whether the sensor specification is correct.	Set the sensor specification properly.
	AC leaks into the sensor circuit.	Use an ungrounded type sensor.
	There may be equipment that interferes with or makes noise near the instrument.	Keep the instrument clear of any potentially disruptive equipment.
[Err 1] is indicated on the PV Display.	The internal memory is defective.	Please contact our main office or dealers.

11.2 Key Operation

Problem	Possible Cause	Solution
<ul style="list-style-type: none"> Settings (SV, P, I, D, proportional cycle, alarm value, etc.) are impossible. The values do not change by the  or  key. 	Set value lock (Lock 1 or Lock 2) is selected.	Release the lock selection.
	Auto-tuning (AT) is performing.	Cancel auto-tuning (AT) if required.
The setting indication does not change within the rated input range even if the  or  key is pressed, and new values are unable to be set.	Scaling high limit or low limit (in Auxiliary function setting mode 2) may be set at the point where the value does not change.	Set it to a suitable value while in Auxiliary function setting mode 2.

11.3 Control

Problem	Possible Cause	Solution
The PV (temperature) does not rise.	The sensor is out of order.	Replace the sensor.
	Check whether the sensor is securely mounted to the instrument input terminals, or control output terminals are securely mounted to the actuator input terminals.	Mount the sensor or control output terminals securely.
	Ensure that wiring of sensor terminals or control output terminals is correct.	Wire them correctly.
The control output remains in an ON status.	OUT low limit value is set to 100% or higher in Auxiliary function setting mode 2.	Set it to a suitable value.
The control output remains in an OFF status.	OUT high limit value is set to 0% or less in Auxiliary function setting mode 2.	Set it to a suitable value.

For all other malfunctions, please contact our main office or dealers.

12. Character Table

12.1 Main Setting Mode

Character	Setting Item, Description, Setting Range	Factory Default
4□□□	SV1 Scaling low limit to scaling high limit (For DC voltage and current inputs, the placement of the decimal point follows the selection.)	0°C

12.2 Sub Setting Mode

Character	Setting Item, Description, Setting Range	Factory Default
AT□□	AT Perform/Cancel ----: AT Cancel AT□□: AT Perform	AT Cancel
P□□□	OUT1 proportional band Setting range: 0.0 to 110.0%	2.5%
P_b□□	OUT2 proportional band Setting range: 0.0 to 10.0 times	1.0 times
I□□□	Integral time Setting range: 0 to 3600 seconds	200 seconds
d□□□	Derivative time Setting range: 0 to 1800 seconds	50 seconds
M□□□	ARW (Anti-reset windup) Setting range: 0 to 100%	50%
c□□□	OUT1 proportional cycle Setting range: 1 to 120 seconds	Relay contact output: 30 seconds Non-contact voltage output: 3 seconds
c_b□□	OUT2 proportional cycle Setting range: 1 to 120 seconds	3 seconds
r4EF	Manual reset ±Proportional band converted value (For DC voltage and current inputs, the placement of the decimal point follows the selection.)	0.0
R1□□	Alarm 1 value See (Table 12.2-1)(p.48). (For DC voltage and current inputs, the placement of the decimal point follows the selection.)	0°C
H□□□と □XX.X alternating display	Heater burnout alarm value Rated current 5 A: 0.0 to 5.0 A Rated current 10 A: 0.0 to 10.0 A Rated current 20 A: 0.0 to 20.0 A Rated current 50 A: 0.0 to 50.0 A	0.0 A
LP_Γ	Loop break alarm time Setting range: 0 to 200 minutes	0 minutes
LP_H	Loop break alarm band Setting range: Thermocouple, RTD inputs: 0 to 150°C (°F) or 0.0 to 150.0°C (°F) DC voltage, current inputs: 0 to 1500 (The placement of the decimal point follows the selection.)	0°C

(Table 12.2-1)

Alarm Type	Setting Range	
High limit alarm	–(Scaling span) to scaling span	Minimum negative value: –199.9 or –1999
Low limit alarm	–(Scaling span) to scaling span	
High/Low limits alarm	0 to scaling span	
High/Low limit range alarm	0 to scaling span	Maximum positive value: 999.9 or 9999
Process high alarm	Scaling low limit value to scaling high limit value	
Process low alarm	Scaling low limit value to scaling high limit value	
High limit with standby alarm	–(Scaling span) to scaling span	
Low limit with standby alarm	–(Scaling span) to scaling span	
High/Low limits with standby alarm	0 to scaling span	
High/Low limits independent alarm	0 to scaling span	
High/Low limit range independent alarm	0 to scaling span	
High/Low limits with standby independent alarm	0 to scaling span	

12.3 Auxiliary Function Setting Mode 1

Character	Setting Item, Setting Range	Factory Default
<i>LocE</i>	Set value lock ---- (Unlock): All set values can be changed. <i>Loc 1</i> (Lock 1): None of the set values can be changed. <i>Loc 2</i> (Lock 2): Only main setting mode can be changed. <i>Loc 3</i> (Lock 3): All set values – except [input type] and [Controller/Converter] – can be changed. However, changed values revert to their previous values after power is turned off because they are not saved in the non-volatile IC memory. Do not change any setting item in Auxiliary function setting mode 2. If any item in Auxiliary function setting mode 2 is changed, it will affect other setting items such as the SV and Alarm value. Be sure to select Lock 3 when changing the set value frequently via software communication. (If a value set by the software communication is the same as the value before the setting, the value will not be written in non-volatile IC memory.)	Unlock
<i>Lo□□</i>	Sensor correction Setting range: Thermocouple, RTD inputs: –100.0 to 100.0°C (°F) DC voltage, current inputs: –1000 to 1000 (The placement of the decimal point follows the selection.)	0.0°C
<i>cn4L</i>	Communication protocol <i>nonL</i> : Shinko protocol <i>nodA</i> : MODBUS ASCII mode <i>nodr</i> : MODBUS RTU mode <i>bn4L</i> : Shinko protocol (Block Read/Write available) <i>bn4A</i> : MODBUS ASCII mode (Block Read/Write available) <i>bn4r</i> : MODBUS RTU mode (Block Read/Write available)	Shinko protocol
<i>cnno</i>	Instrument number Setting range: 0 to 95	0
<i>cn4P</i>	Communication speed <input type="checkbox"/> 24: 2400 bps <input type="checkbox"/> 48: 4800 bps <input type="checkbox"/> 96: 9600 bps <input type="checkbox"/> 192: 19200 bps <input type="checkbox"/> 384: 38400 bps	9600 bps
<i>cnPr</i>	Parity <i>nonE</i> : No parity <i>EbEn</i> : Even <i>odd□</i> : Odd	Even
<i>cn4f</i>	Stop bit 1 bit, 2 bits	1 bit

12.4 Auxiliary Function Setting Mode 2

Character	Setting Item, Setting Range	Factory Default
4En4	Input type E□□C: K -200 to 1370°C E□□F: K -320 to 2500°F E□□C: -199.9 to 400.0°C E□□F: -199.9 to 750.0°F J□□C: J -200 to 1000°C J□□F: J -320 to 1800°F r□□C: R 0 to 1760°C r□□F: R 0 to 3200°F 4□□C: S 0 to 1760°C 4□□F: S 0 to 3200°F b□□C: B 0 to 1820°C b□□F: B 0 to 3300°F E□□C: E -200 to 800°C E□□F: E -320 to 1500°F T□□C: T -199.9 to 400.0°C T□□F: T -199.9 to 750.0°F n□□C: N -200 to 1300°C n□□F: N -320 to 2300°F PL2C: PL-II 0 to 1390°C PL2F: PL-II 0 to 2500°F c□□C: C(W/Re5-26) 0 to 2315°C c□□F: C(W/Re5-26) 0 to 4200°F Pt1C: Pt100 -199.9 to 850.0°C Pt1F: Pt100 -199.9 to 999.9°F JPt1C: JPt100 -199.9 to 500.0°C JPt1F: JPt100 -199.9 to 900.0°F Pt1C: Pt100 -200 to 850°C Pt1F: Pt100 -300 to 1500°F JPt1C: JPt100 -200 to 500°C JPt1F: JPt100 -300 to 900°F 420A: 4 to 20 mA DC -1999 to 9999 (Externally mounted 50 Ω shunt resistor) 020A: 0 to 20 mA DC -1999 to 9999 (Externally mounted 50 Ω shunt resistor) 0□1B: 0 to 1 V DC -1999 to 9999 0□5B: 0 to 5 V DC -1999 to 9999 1□5B: 1 to 5 V DC -1999 to 9999 0□10B: 0 to 10 V DC -1999 to 9999 420I : 4 to 20 mA DC -1999 to 9999 (Built-in 50 Ω shunt resistor) 020I : 0 to 20 mA DC -1999 to 9999 (Built-in 50 Ω shunt resistor)	K(-200 to 1370°C)
4FLH	Scaling high limit Setting range: Scaling low limit to input range high limit (For DC voltage and current inputs, the placement of the decimal point follows the selection.)	1370°C
4FLI	Scaling low limit Setting range: Input range low limit to scaling high limit (For DC voltage and current inputs, the placement of the decimal point follows the selection.)	-200°C
dP□□	Decimal point place □□□0: No decimal point □□□0: 1 digit after decimal point □□□0: 2 digits after decimal point □□□0: 3 digits after decimal point	No decimal point
F1LF	PV filter time constant Setting range: 0.0 to 10.0 seconds	0.0 seconds
oLH□	OUT1 high limit Setting range: OUT1 low limit value to 100% (Direct current output type: OUT1 low limit value to 105%)	100%
oLL□	OUT1 low limit Setting range: 0% to OUT1 high limit value (Direct current output type: -5% to OUT1 high limit value)	0%
H44□	OUT1 ON/OFF hysteresis Thermocouple, RTD inputs: 0.1 to 100.0°C (°F) DC voltage, current inputs: 1 to 1000 (The placement of the decimal point follows the selection.)	1.0°C
cRcF	OUT2 cooling method Air□□: Air cooling Oil□□: Oil cooling Water□□: Water cooling	Air cooling

Character	Setting Item, Setting Range	Factory Default
<i>oLHb</i>	OUT2 high limit Setting range: OUT2 low limit value to 100%	100%
<i>oLLb</i>	OUT2 low limit Setting range: 0% to OUT2 high limit value	0%
<i>db□□</i>	Overlap/Dead band Thermocouple, RTD inputs: -100.0 to 100.0°C (°F) DC voltage, current inputs: 1 to 1000 (The placement of the decimal point follows the selection.)	0.0°C
<i>HhYb</i>	OUT2 ON/OFF hysteresis Thermocouple, RTD inputs: 0.1 to 100.0°C (°F) DC voltage, current inputs: 1 to 1000 (The placement of the decimal point follows the selection)	1.0°C
<i>ALIF</i>	Alarm 1 type ---- : No alarm action <i>H□□□</i> : High limit alarm <i>L□□□</i> : Low limit alarm <i>HL□□</i> : High/Low limits alarm <i>□□ d□</i> : High/Low limit range alarm <i>AL□□</i> : Process high alarm <i>rAL□</i> : Process low alarm <i>H□□□</i> : High limit with standby alarm <i>L□□□</i> : Low limit with standby alarm <i>HL□□</i> : High/Low limits with standby alarm <i>!HL□□</i> : High/Low limits independent alarm <i>!□□ d</i> : High/Low limit range independent alarm <i>!HL□□</i> : High/Low limits with standby independent alarm	No alarm action
<i>ALn</i>	Alarm 1 Energized/De-energized <i>noñL</i> : Energized <i>rEBh</i> : De-energized	Energized
<i>ALhd</i>	Alarm 1 HOLD function <i>noñE</i> : Not holding <i>HoLd</i> : Holding	Not holding
<i>ALHy</i>	Alarm 1 hysteresis Setting range: Thermocouple, RTD inputs: 0.1 to 100.0°C (°F) DC voltage, current inputs: 1 to 1000 (The placement of the decimal point follows the selection.)	1.0°C
<i>ALdy</i>	Alarm 1 delay time Setting range: 0 to 9999 seconds	0 seconds
<i>conf</i>	Direct/Reverse action <i>HEAT</i> : Reverse (Heating) action <i>cool</i> : Direct (Cooling) action	Reverse (Heating) action
<i>AT_b</i>	AT bias Setting range: 0 to 50°C (0 to 100°F), or 0.0 to 50.0°C (0.0 to 100.0°F)	20°C
<i>VB_b</i>	SVTC bias Setting range: ±20% of the scaling span	0
<i>EOUF</i>	Output status when input errors occur <i>oFF□</i> : Output OFF: Outputs OFF(4mA) or OUT1 low limit value. <i>oN□□</i> : Output ON: Outputs a value between OFF (4 mA) and ON (20 mA) or between OUT1 low limit value and OUT1 high limit value, depending on deviation.	Output OFF
<i>Func</i>	Controller/Converter <i>conf</i> : Controller <i>cnbf</i> : Converter	Controller

12.5 Auxiliary Function Setting Mode 3

Character	Setting Item, Setting Range	Factory Default			
E1 n□	Event input DI allocation	No event			
			Event Input Function	Input ON (Closed)	Input OFF (Open)
	□000		No event		
	□001		Set value memory	SV2	SV1
	□002		Control ON/OFF	Control OFF	Control ON
	□003		Direct/Reverse action	Direct	Reverse
	□004		Preset output 1 ON/OFF	Preset output	Usual control
	□005		Preset output 2 ON/OFF	Preset output	Usual control
	□006		Auto/Manual control	Manual	Automatic
	□007		Integral action Holding (Stop)/Usual integral action	Integral action Holding (Stop)	Usual integral action
	□008		Set value memory	SV1	SV2
	□009		Control ON/OFF	Control ON	Control OFF
	□010		Direct/Reverse action	Reverse	Direct
	□011		Preset output 1 ON/OFF	Usual control	Preset output
	□012		Preset output 2 ON/OFF	Usual control	Preset output
	□013		Auto/Manual control	Automatic	Manual
	□014		Integral action Holding (Stop)/Usual integral action	Usual integral action	Integral action Holding (Stop)
□001 to □007: Functions work when Event input DI is closed. □008 to □014: Functions work when Event input DI is open.					
42□□	SV2 Setting range: Scaling low limit to Scaling high limit	0°C			
R12R	Alarm 1 value 0 Enabled/Disabled n0□□: Disabled 4E4□: Enabled	Disabled			
R1H□	Alarm 1 high limit alarm value See (Table 12.2-1) on p.48. (For DC voltage and current inputs, the placement of the decimal point follows the selection)	0°C			
RL2F	Alarm 2 type ---- : No alarm action H□□□: High limit alarm L□□□: Low limit alarm HL□□: High/Low limits alarm □1 d□: High/Low limit range alarm R4□□: Process high alarm rR4□: Process low alarm H□□□: High limit with standby alarm L□□□: Low limit with standby alarm HL□□: High/Low limits with standby alarm 1HL□: High/Low limits independent alarm 1□1 d□: High/Low limit range independent alarm 1HL□: High/Low limits with standby independent alarm	No alarm action			

Character	Setting Item, Setting Range	Factory Default
<i>R2E</i>	Alarm 2 value 0 Enabled/Disabled <i>no</i> : Disabled <i>YE</i> : Enabled	Disabled
<i>R2</i>	Alarm 2 value See (Table 12.2-1) on p.48. (For DC voltage and current inputs, the placement of the decimal point follows the selection.)	0°C
<i>R2H</i>	Alarm 2 high limit alarm value See (Table 12.2-1) on p.48. (For DC voltage and current inputs, the placement of the decimal point follows the selection.)	0°C
<i>R2L</i>	Alarm 2 Energized/De-energized <i>no</i> : Energized <i>rE</i> : De-energized	Energized
<i>R2Hd</i>	Alarm 2 HOLD function <i>no</i> : Not holding <i>HoLd</i> : Holding	Not holding
<i>R2HY</i>	Alarm 2 hysteresis Setting range: Thermocouple, RTD inputs: 0.1 to 100.0°C (°F) DC voltage, current inputs: 1 to 1000 (The placement of the decimal point follows the selection.)	1.0°C
<i>R2dy</i>	Alarm 2 delay time Setting range: 0 to 9999 seconds	0 seconds
<i>AL3F</i>	Alarm 3 type ---- : No alarm action <i>H</i> : High limit alarm <i>L</i> : Low limit alarm <i>HL</i> : High/Low limits alarm <i>o</i> <i>d</i> : High/Low limit range alarm <i>R</i> : Process high alarm <i>rR</i> : Process low alarm <i>H</i> <i>o</i> : High limit with standby alarm <i>L</i> <i>o</i> : Low limit with standby alarm <i>HL</i> <i>o</i> : High/Low limits with standby alarm <i>I</i> <i>HL</i> : High/Low limits independent alarm <i>I</i> <i>o</i> <i>d</i> : High/Low limit range independent alarm <i>I</i> <i>HL</i> <i>o</i> : High/Low limits with standby independent alarm	No alarm action
<i>R3E</i>	Alarm 3 value 0 Enabled/Disabled <i>no</i> : Disabled <i>YE</i> : Enabled	Disabled
<i>R3</i>	Alarm 3 value See (Table 12.2-1) on p.48. (For DC voltage and current inputs, the placement of the decimal point follows the selection.)	0°C
<i>R3H</i>	Alarm 3 high limit alarm value See (Table 12.2-1) on p.48. (For DC voltage and current inputs, the placement of the decimal point follows the selection.)	0°C
<i>R3L</i>	Alarm 3 Energized/De-energized <i>no</i> : Energized <i>rE</i> : De-energized	Energized

Character	Setting Item, Setting Range	Factory Default
<i>R3Hd</i>	Alarm 3 HOLD function <i>nonE</i> : Not holding <i>HoLd</i> : Holding	Not holding
<i>R3HY</i>	Alarm 3 hysteresis Setting range: Thermocouple, RTD inputs: 0.1 to 100.0°C (°F) DC voltage, current inputs: 1 to 1000 (The placement of the decimal point follows the selection.)	1.0°C
<i>R3dY</i>	Alarm 3 delay time Setting range: 0 to 9999 seconds	0 seconds
<i>AL4F</i>	Alarm 4 type ---- : No alarm action <i>H</i> □□□: High limit alarm <i>L</i> □□□: Low limit alarm <i>HL</i> □□: High/Low limits alarm <i>ū d</i> □□: High/Low limit range alarm <i>A4</i> □□: Process high alarm <i>rA4</i> □□: Process low alarm <i>H</i> □□ <i>ū</i> : High limit with standby alarm <i>L</i> □□ <i>ū</i> : Low limit with standby alarm <i>HL</i> □□ <i>ū</i> : High/Low limits with standby alarm <i>IHL</i> □□: High/Low limits independent alarm <i>I ū d</i> □□: High/Low limit range independent alarm <i>IHL ū</i> : High/Low limits with standby independent alarm	No alarm action
<i>R4EA</i>	Alarm 4 value 0 Enabled/Disabled <i>no</i> □□: Disabled <i>YE4</i> □□: Enabled	Disabled
<i>R4</i> □□	Alarm 4 value See (Table 12.2-1) on p.48. (For DC voltage and current inputs, the placement of the decimal point follows the selection.)	0°C
<i>R4H</i> □□	Alarm 4 high limit alarm value See (Table 12.2-1) on p.48. (For DC voltage and current inputs, the placement of the decimal point follows the selection.)	0°C
<i>R4Lā</i>	Alarm 4 Energized/De-energized <i>noāL</i> : Energized <i>rEB4</i> : De-energized	Energized
<i>R4Hd</i>	Alarm 4 HOLD function <i>nonE</i> : Not holding <i>HoLd</i> : Holding	Not holding
<i>R4HY</i>	Alarm 4 hysteresis Thermocouple, RTD inputs: 0.1 to 100.0°C (°F) DC voltage, current inputs: 1 to 1000 (The placement of the decimal point follows the selection.)	1.0°C
<i>R4dY</i>	Alarm 4 delay time Setting range: 0 to 9999 seconds	0 seconds
<i>rEāF</i>	Remote/Local <i>LoCL</i> : Local <i>rEāF</i> : Remote	Local
<i>rF_b</i>	Remote bias Setting range: ±20% of input span	0°C

Character	Setting Item, Setting Range	Factory Default
rFLH	External setting input high limit Setting range: External setting input low limit to Scaling high limit	1370°C
rFLl	External setting input low limit Setting range: Scaling low limit to External setting input high limit	-200°C
rR44	SV Rise/Fall rate start type 484F: SV start P84F: PV start	SV start
rRFU	SV rise rate Setting range: 0 to 9999 °C/min. (°F/min.) (The placement of the decimal point follows the selection.) Thermocouple, RTD inputs: 0.0 to 999.9 °C/min. (°F/min.) DC voltage, current inputs: 0 to 9999/min.	0 °C/minute
rRFd	SV fall rate Setting range: 0 to 9999 °C/min. (°F/min.) (The placement of the decimal point follows the selection.) Thermocouple, RTD inputs: 0.0 to 999.9 °C/min. (°F/min.) DC voltage, current inputs: 0 to 9999/min.	0 °C/minute
PoUF	Control output OUT1/EVT oUF 1: OUT1 E8F: EVT	OUT1
Ho4L	Heater burnout alarm output Enabled/Disabled no: Disabled 4E4: Enabled	Enabled
LP4L	Loop break alarm output Enabled/Disabled no: Disabled 4E4: Enabled	Enabled
R14L	Alarm 1 output Enabled/Disabled no: Disabled 4E4: Enabled	Enabled
R24L	Alarm 2 output Enabled/Disabled no: Disabled 4E4: Enabled	Disabled
R34L	Alarm 3 output Enabled/Disabled no: Disabled 4E4: Enabled	Disabled
R44L	Alarm 4 output Enabled/Disabled no: Disabled 4E4: Enabled	Disabled
P4F1	OUT1 MV Preset value Setting range: OUT1 low limit to OUT1 high limit	0.0%
P4F2	OUT2 MV Preset value Setting range: OUT2 low limit to OUT2 high limit	0.0%
rRnU	SUB-MODE key function oFF: Control output OFF rRnU: Auto/Manual control ALoF: Alarm HOLD cancel	Control output OFF
rRr4	Auto/Manual control after power ON RUFo: Automatic control rRnU: Manual control	Automatic control

Key Operation Flowchart

Basic Operation Procedure

Set the input type, Alarm 1 type and SV1 (desired value), following the procedure below. Setting item numbers (1), (2), (3), (4), (5), (6), (7) and (8) are indicated on the flowchart.

[Step 1] Operation before RUN	Turn the load circuit power OFF, and turn the power to the DCL-33A ON.
[Step 2] Auxiliary function setting mode 2	Select an input type and Alarm 1 type, etc. in Auxiliary function setting mode 2. (1) Select an input type in [Input type]. (2) Select Alarm 1 type in [Alarm 1 type]. If any Alarm 1 type except ("----") is selected, (3) to (6) will be indicated. Set them if necessary. Note: If Alarm 1 type is changed, the Alarm 1 value will default to 0 (0.0). Therefore, set the alarm value again. (3) Select either Energized or De-energized in [Alarm 1 Energized/De-energized]. (4) Select either Holding or Not holding in [Alarm 1 HOLD function]. (5) Set Alarm 1 hysteresis in [Alarm 1 hysteresis]. (6) Set Alarm 1 delay time in [Alarm 1 delay time]. (7) Set Alarm 1 value in [Alarm 1 value].
[Step 3] Sub setting mode	(8) Set SV1 (desired value) in [SV1 (desired value)].
[Step 4] Main setting mode	Turn the load circuit power ON. Control action starts so as to keep the control target at SV1 (desired value).
[Step 5] RUN	

Alarm Type

High limit alarm	The alarm action is \pm deviation setting from the SV. The alarm is activated if the input value reaches the high limit set value.
Low limit alarm	The alarm action is \pm deviation setting from the SV. The alarm is activated if the input value drops below the low limit set value.
High/Low limits alarm	Combines High limit and Low limit alarm actions. When input value reaches the high limit set value or drops below the low limit set value, the alarm is activated.
High/Low limit range alarm	When input value is between the low limit and high limit set values, the alarm is activated.
Process alarm	Within the scale range of the controller, alarm action points can be set at random and if the input reaches the randomly set action point, the alarm is activated.
High/Low limits independent	High limit and low limit set values can be set respectively. The alarm is activated when the input value exceeds the high limit set value or drops below the low limit set value.
High/Low limit range independent	High limit and low limit set values can be set respectively. The alarm is activated when the input value is between the low limit and high limit set values.
High limit with standby, Low limit with standby, H/L limits with standby	After the power supply to the instrument is turned on, even if the input enters the alarm action range, the alarm is not activated. If SV is changed while the controller is running, the alarm is not activated even if the input is in the alarm action range. (If the controller is allowed to keep running, the standby function will be released once the input exceeds the alarm action point.)

Character Indication

AT Perform/Cancel	Input Type	C	C(W/Re5-26)	H/L	H/L limits alarm	cnhf	Converter	SV Rise/Fall rate start type
---- AT Cancel	K -200 -1370°C	PF	PT100 -199.9 -999.9°F	ul	H/L limit range	000	No event	484r SV start
AT Perform	-199.9 -400.0°C	JP	JP100 -199.9 -900.0°F	Rh	Process high alarm	001	Set value memory	PH4r PV start
Set value lock	J -200 -1000°C	PL	PL100 -300 -1500°F	Rl	Process low alarm	002	Control ON/OFF	Control output OUT1/EVT
---- Unlock	R 0 -1760°C	PL2	PL100 -300 -900°F	Hl	High limit with standby	003	Direct/Reverse action	OUT1
Loc1 Lock 1	S 0 -1760°C	PL3	PL100 -300 -900°F	Ll	Low limit with standby	004	Preset output 1 ON/OFF	EVT
Loc2 Lock 2	B 0 -1820°C	E	0 -1 V -1999 -9999	Hl	H/L limits with standby	005	Preset output 2 ON/OFF	Heater burnout alarm output Enabled/Disabled
Loc3 Lock 3	E -200 -800°C	T	-199.9 -400.0°C	il	H/L limits independent	006	Auto/Manual control	Disabled
Communication protocol	N -200 -1300°C	PL	PL-II 0 -1390°C	HL	H/L limits independent alarm	007	Integral action Holding	Enabled/Disabled
Shinko protocol	Modbus ASCII mode	C	C(W/Re5-26) 0 -2315°C	HL	H/L limits with standby independent alarm	008	Set value memory	Disabled
Modbus ASCII mode	Modbus RTU mode	PL	PL100 -199.9 -850.0°C	HL	H/L limits with standby independent alarm	009	Control ON/OFF	Enabled
Modbus RTU mode	Shinko protocol (Block Read/Write)	PL	PL100 -199.9 -500.0°C	A1 - A4	Energized/De-energized	010	Direct/Reverse action	A1 - A4 output Enabled/Disabled
Modbus ASCII mode (Block Read/Write)	Modbus ASCII mode (Block Read/Write)	PL	PL100 -200 -850.0°C	RE	De-energized	011	Preset output 1 ON/OFF	Disabled
Modbus RTU mode (Block Read/Write)	Modbus RTU mode (Block Read/Write)	PL	PL100 -200 -500.0°C	A1 - A4	HOLD function	012	Preset output 2 ON/OFF	Enabled
Communication speed	Parity	K	-199.9 -750.0°F	Hold	Holding	013	Auto/Manual control	Control output OFF
24 2400 bps	No parity	J	-320 -1800°F	HE	Reverse action	014	Integral action Holding	Auto/Manual control
48 4800 bps	Even	R	0 -3200°F	CO	Direct action	A1 - A4	A1 - A4 value 0 Enabled/Disabled	Alarm HOLD cancel
96 9600 bps	Odd	S	0 -3200°F	Output status when input errors occur	Output OFF	000	Disabled	Auto/Manual control after power ON
192 19200 bps		B	0 -3300°F	OFF	Output ON	4E4	Enabled	Automatic control
384 38400 bps		E	-320 -1500°F	ON	Output ON	LocL	Local	Manual control
		T	-199.9 -750.0°F	HL	High limit alarm	cnf	Controller	
		N	-320 -2300°F	Ll	Low limit alarm			
		PL-II	0 -2500°F					

About Setting Item

- Upper left** : PV Display: Indicates setting characters. **Lower left**: SV Display: Indicates the factory default.
- Right side** : Indicates the setting item.
- []** : This setting item is optional, and appears only when the option is ordered.

Key Operation

- [] + []** : Press and hold the [] key and [] key (in that order).
- [] + []** (For 3 sec): Press and hold the [] key and [] key (in that order) together for approx. 3 seconds.
- [] + []** (For 3 sec): Press and hold the [] key and [] key (in that order) together for approx. 3 seconds.
- [] + []** (For 3 sec): Press and hold the [] key and [] key (in that order) together for approx. 3 seconds.
- []** : If the [] key is pressed, the unit proceeds to the next item, illustrated by an arrow.
- To revert to the PV/SV Display, press the [] key for approx. 3 seconds in any mode.

(*1) Externally mounted 50Ω shunt resistor (*2) Built-in 50Ω shunt resistor
(*3) 001 to 007: Works when contacts are closed (Input ON).
008 to 014: Works when contacts are open (Input OFF).

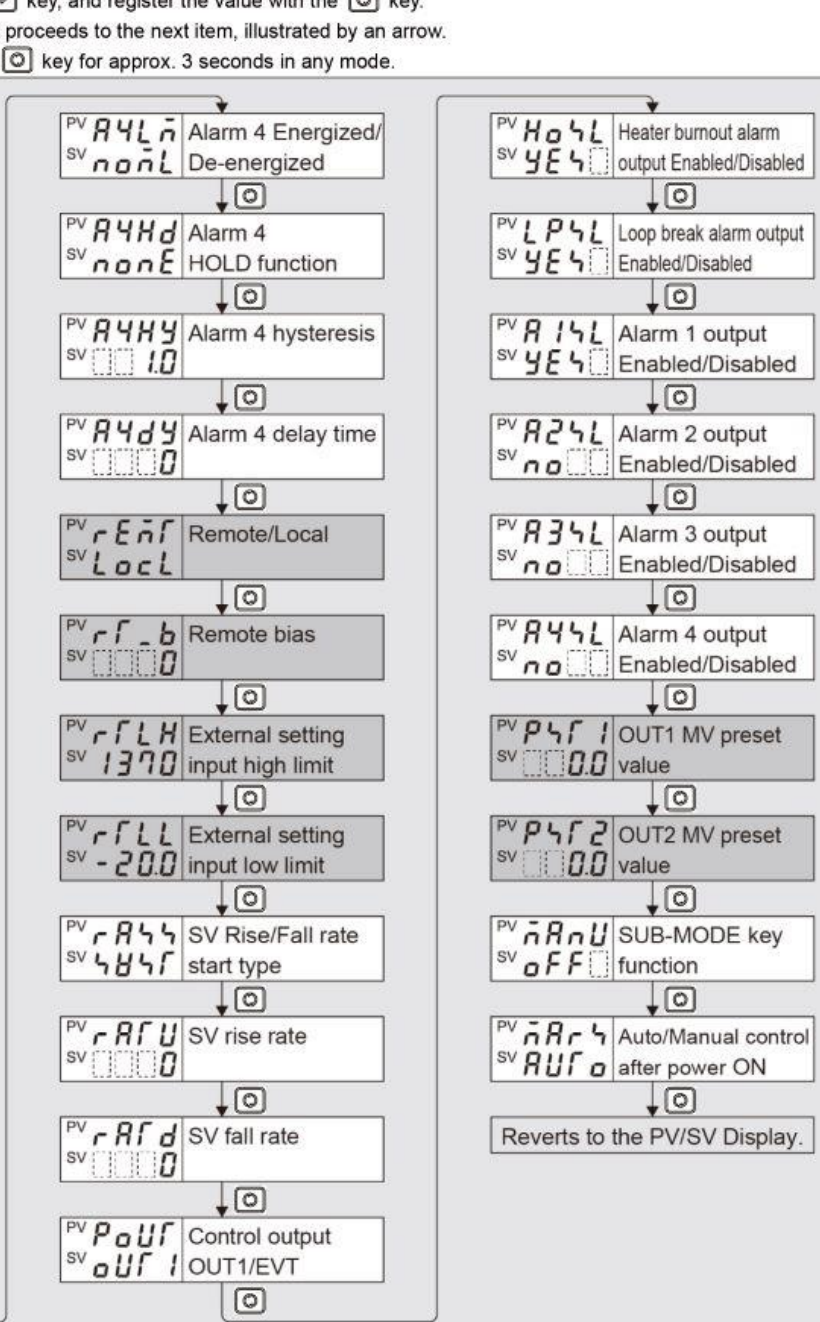
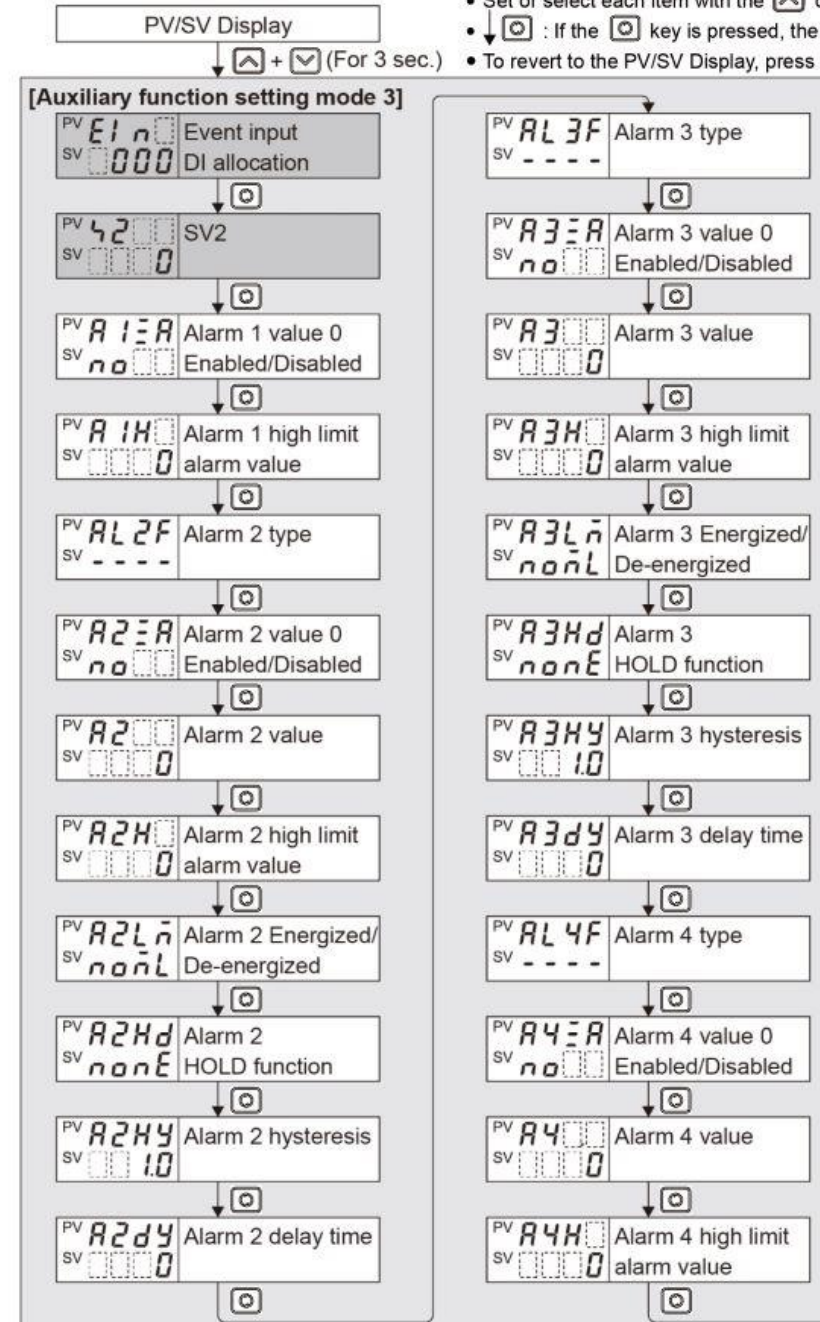
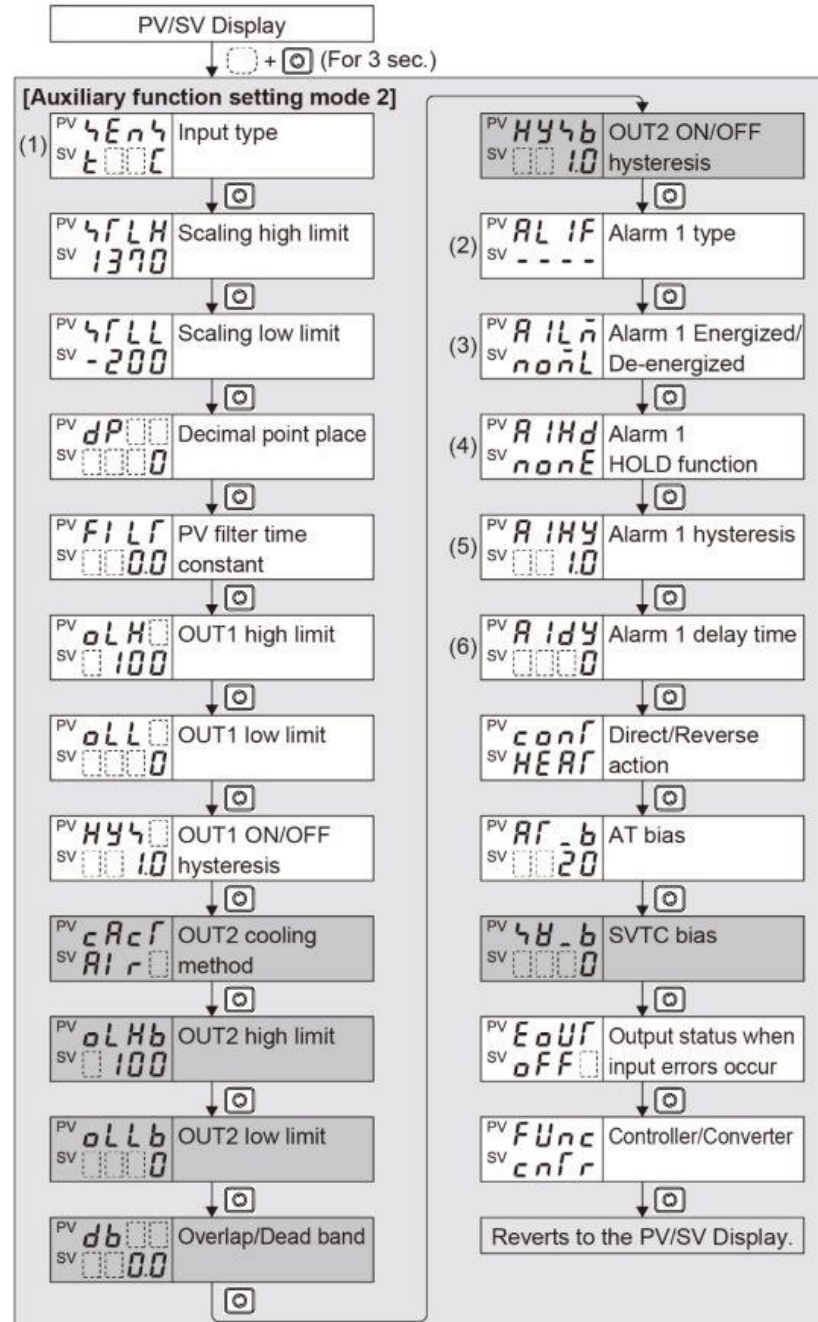
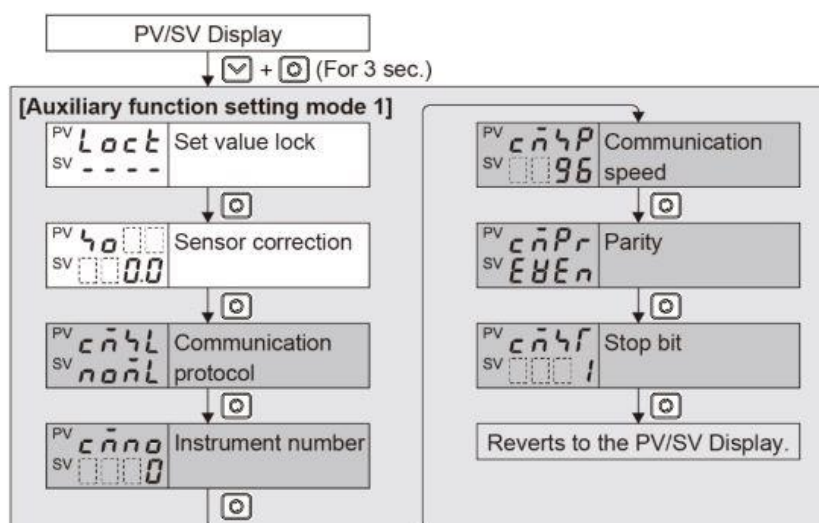
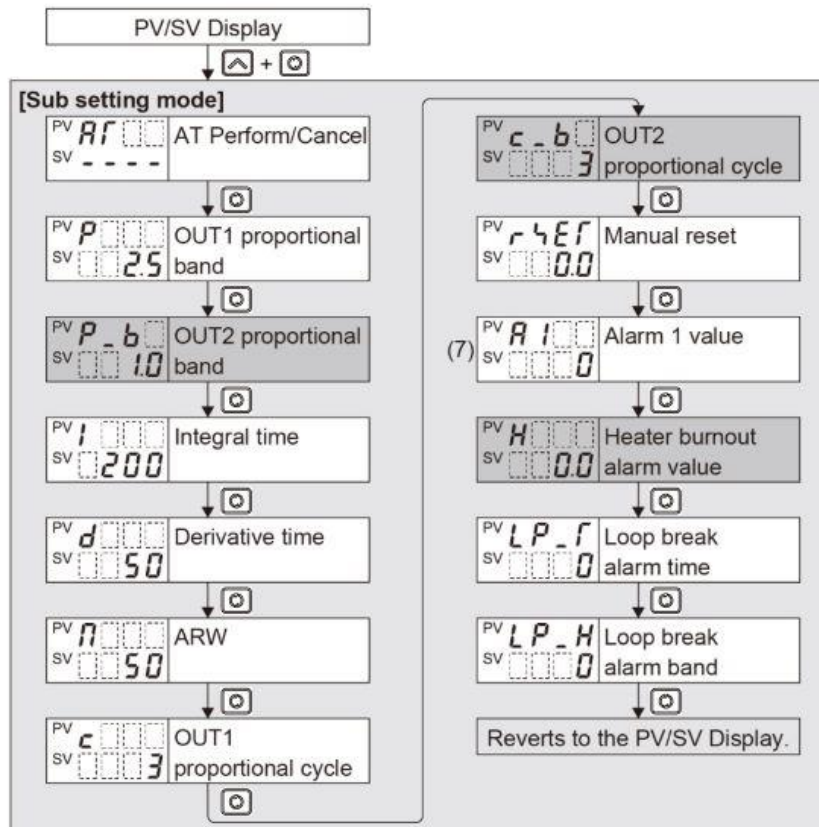
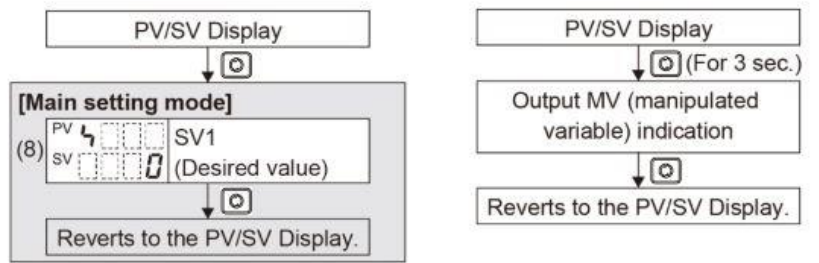

SHINKO TECHNOS CO., LTD.

OVERSEAS DIVISION

Head Office: 2-5-1, Senbahigashi, Minoo, Osaka, 562-0035, Japan

[URL] <https://shinko-technos.co.jp/e/>

[E-mail] overseas@shinko-technos.co.jp

Tel: +81-72-727-6100

Fax: +81-72-727-7006