

4 points Analog I/O Module

QAM1-4

INSTRUCTION MANUAL

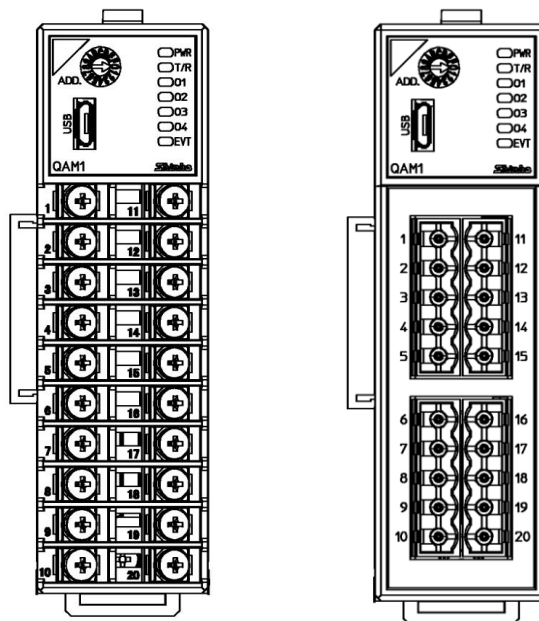

Shinko

Preface

Thank you for purchasing our 4 points analog I/O module [QAM1-4].

This manual contains instructions for the mounting, functions, operations and notes when operating the 4 points analog I/O module [QAM1-4].

To prevent accidents arising from the misuse of this instrument, please ensure the operator receives this manual

Notes

- This instrument should be used in accordance with the specifications described in the manual. If it is not used according to the specifications, it may malfunction or cause a fire.
- Be sure to follow the warnings, cautions and notices. If they are not observed, serious injury or malfunction may occur.
- The contents of this instruction manual are subject to change without notice.
- Care has been taken to ensure that the contents of this instruction manual are correct, but if there are any doubts, mistakes or questions, please inform our sales department.
- This instrument is designed to be installed on a DIN rail within a control panel indoors. If it is not, measures must be taken to ensure that the operator does not touch power terminals or other high voltage sections.
- Any unauthorized transfer or copying of this document, in part or in whole, is prohibited.
- Shinko Technos Co., Ltd. is not liable for any damage or secondary damage(s) incurred as a result of using this product, including any indirect damage.

SAFETY PRECAUTIONS (Be sure to read these precautions before using our products.)

The safety precautions are classified into categories: "Warning" and "Caution".

Depending on circumstances, procedures indicated by ⚠ Caution may result in serious consequences, so be sure to follow the directions for usage.



Warning

Procedures which may lead to dangerous conditions and cause death or serious injury, if not carried out properly.



Caution

Procedures which may lead to dangerous conditions and cause superficial to medium injury or physical damage or may degrade or damage the product, if not carried out properly.



Warning

- To prevent an electrical shock or fire, only Shinko or qualified service personnel may handle the inner assembly.
- To prevent an electrical shock, fire, or damage to instrument, parts replacement may only be undertaken by Shinko or qualified service personnel.



Safety Precautions

- To ensure safe and correct use, thoroughly read and understand this manual before using this instrument.
- This instrument is intended to be used for industrial machinery, machine tools and measuring equipment. Verify correct usage after purpose-of-use consultation with our agency or main office. (Never use this instrument for medical purposes with which human lives are involved.)
- External protection devices such as protective equipment against excessive temperature rise, etc. must be installed, as malfunction of this product could result in serious damage to the system or injury to personnel. Proper periodic maintenance is also required.
- This instrument must be used under the conditions and environment described in this manual. Shinko Technos Co., Ltd. does not accept liability for any injury, loss of life or damage occurring due to the instrument being used under conditions not otherwise stated in this manual.



Caution with Respect to Export Trade Control Ordinance

To avoid this instrument from being used as a component in, or as being utilized in the manufacture of weapons of mass destruction (i.e. military applications, military equipment, etc.), please investigate the end users and the final use of this instrument.

In the case of resale, ensure that this instrument is not illegally exported.

Precautions for Use

1. Installation Precautions



Caution

This instrument is intended to be used under the following environmental conditions (EN61010-1):

- Overvoltage Category II, Pollution degree 2

Ensure the mounting location corresponds to the following conditions:

- A minimum of dust, and an absence of corrosive gases
- No flammable, explosive gases
- No mechanical vibrations or shocks
- No exposure to direct sunlight, an ambient temperature of -10 to 50°C (14°F to 122°F) that does not change rapidly, and no icing
- An ambient non-condensing humidity of 35 to 85%RH
- No large capacity electromagnetic switches or cables through which large current is flowing
- No water, oil or chemicals or the vapors of these substances can come into direct contact with the unit.
- When installing this unit within a control panel, please note that ambient temperature of this unit – not the ambient temperature of the control panel – must not exceed 50°C (122°F).

Otherwise the life of electronic components (especially electrolytic capacitor) may be shortened.

- * Avoid setting this instrument directly on or near flammable material even though the case of this instrument is made of flame-resistant resin.

2. Wiring Precautions



Caution

- Do not leave bits of wire in the instrument, because they could cause a fire and malfunction.
- When wiring, use a crimping pliers and a solderless terminal with an insulation sleeve in which an M3 screw fits.
- The terminal block of this instrument has a structure that is wired from the left side. Be sure to insert the lead wire into the terminal of the instrument from the left side and tighten the terminal screw.
- Tighten the terminal screw using the specified torque. If excessive force is applied to the screw when tightening, the screw or case may be damaged.
- Do not pull or bend the lead wire with the terminal as the base point during or after wiring work. It may cause malfunction.
- This instrument does not have a built-in power switch, circuit breaker and fuse. It is necessary to install a power switch, circuit breaker and fuse near the instrument.
(Recommended fuse: Time-lag fuse, rated voltage 250 V AC, rated current 2 A)
- When wiring the power supply (24 VDC), do not confuse the polarities.
- Do not apply a commercial power source to the sensor which is connected to the input terminal nor allow the power source to come into contact with the sensor.
- Use the thermocouple and compensation lead wire that match the sensor input specifications of the instrument.
- Use a RTD of 3-conducting wire type that meets the sensor input specifications of this instrument.
- Separate the input line (thermocouple, RTD, etc.) from the power line and load line.

3. Operation and Maintenance Precautions



Caution

- Do not touch live terminals. This may cause electrical shock or problems in operation.
- Turn the power supply to the instrument OFF when retightening the terminal or cleaning. Working on or touching the terminal with the power switched ON may result in severe injury or death due to electrical shock.
- Use a soft, dry cloth when cleaning the instrument.
(Alcohol based substances may tarnish or deface the unit.)
- As the panel part is vulnerable, be careful not to put pressure on, scratch or strike it with a hard object.

- The following abbreviations are used in the text, figures, and tables of this manual.

Symbol	Term
PV	Process variable (PV)

- About description of reference page

In the case of "Refer to 2-2.", it is described as (P.2-2).

- How to read this manual

- When connecting to host computer

Refer to "1 Overview" to "12 Operation".

Refer to "15 Action Explanation" to "18 Troubleshooting" as necessary.

- When connecting to PLC

Refer to "1 Overview" to "3 Name and Functions" and "13 Communication with PLC Using SIF Function".

Refer to "15 Action Explanation" to "18 Troubleshooting" as necessary.

- When connecting to CUnet

Refer to "1 Overview" to "3 Name and Functions" and "14 CUnet Communication".

Refer to "15 Action Explanation" to "18 Troubleshooting" as necessary.

Contents

1	Overview	1-1
1.1	Overview of Analog I/O Module QAM1-4.....	1-1
1.2	Description of Module.....	1-2
1.3	System Configuration	1-4
1.3.1	Connecting to Host Computer	1-4
1.3.2	Connecting to PLC	1-6
1.3.3	Connecting to CUNet	1-9
1.4	Parameter Passing.....	1-10
1.4.1	Using the Analog I/O Module QAM1-4P (with power supply / host communication function) 1-10	
1.4.2	Using the Communication Expansion Module QMC1.....	1-10
2	Model.....	2-1
2.1	Model	2-1
2.2	How to Read the Model Label	2-3
3	Name and Functions	3-1
3.1	Analog I/O Module QAM1-4	3-1
4	Procedure Before Starting Operation.....	4-1
5	Communication Parameter Setting	5-1
5.1	Communication Parameter Setting.....	5-1
5.1.1	Selection of Communication Specifications	5-1
5.1.2	Setting of Module Address.....	5-4
6	Mounting.....	6-1
6.1	Selection of Location	6-2
6.2	External Dimensions (Scale: mm)	6-2
6.3	Mounting.....	6-4
7	Wiring	7-1
7.1	Recommended Terminal and Recommended Rod Terminal	7-1
7.2	Using Terminal Cover Precaution	7-2
7.3	Terminal Arrangement	7-2
7.3.1	Input and Output Terminal Arrangement	7-2
7.3.2	Power Supply and Serial Communication Terminal Arrangement.....	7-4
7.4	Wiring	7-5
7.4.1	Wiring for Power Supply and Communication	7-5
7.4.2	Wiring for Input and Output.....	7-7
7.5	Connection of Host Computer and Analog I/O Module QAM1-4.....	7-9
7.5.1	Wiring Example for Using USB Communication Cable CMC-001-1 (Sold separately)	7-9
7.5.2	Wiring Example for Using Communication Converter IF-400 (Sold separately)	7-10
8	Setting of Specification.....	8-1
8.1	Preparation.....	8-1

8.1.1	Preparation of USB Communication Cable and Console Software	8-1
8.1.2	Connecting to Host Computer	8-1
8.2	Specification Setting	8-6
8.2.1	Monitoring Value Setting.....	8-8
8.2.2	Input Setting	8-10
8.2.3	Standard Function Setting	8-13
8.2.4	Option Function Setting	8-14
9	Communication Procedure	9-1
10	MODBUS Protocol	10-1
10.1	Transmission Mode	10-1
10.2	Data Communication Interval	10-1
10.3	Message Configuration	10-1
10.4	Message Example	10-3
11	Communication Command List	11-1
11.1	Communication Command List	11-1
11.2	Data	11-10
11.2.1	Notes About Write/Read Command	11-10
11.2.2	Write Command.....	11-10
11.2.3	Read Command	11-10
11.3	Negative Acknowledgement	11-10
11.3.1	Error Code 2 (02H)	11-10
11.3.2	Error Code 3 (03H)	11-10
11.3.3	Error Code 17 (11H)	11-10
11.4	Notes on Programming Monitoring Software	11-11
11.4.1	How to Speed up the Scan Time	11-11
11.4.2	Notes on Batch Transmission of All Setting Values	11-11
11.5	Initialization Items by Changing Settings	11-11
12	Operation.....	12-1
12.1	Start measurement.....	12-1
12.2	Correct PV.....	12-3
13	Communication with PLC Using SIF Function	13-1
13.1	Flow of Before Operation.....	13-2
13.2	PLC Communication Parameter Setting.....	13-3
13.3	Mounting.....	13-6
13.4	Wiring	13-8
13.4.1	Wiring for Power Supply and Communication	13-8
13.4.2	Wiring for Input and Output.....	13-10
13.5	Connection of PLC and Control Module QTC1-4P	13-11
13.6	Specification Setting	13-13
13.6.1	Preparation of USB Communication Cable and Console Software	13-13
13.6.2	Connecting to Host Computer	13-13
13.6.3	Specification Setting	13-17
13.7	Operation.....	13-34

13.7.1	Communication Procedure	13-34
13.7.2	PLC Communication Data Map	13-35
13.7.3	Data Exchange between Control Module QTC1-4 and P-PLC	13-43
13.7.4	Data Settings	13-44
14	CUnet Communication	14-1
14.1	Flow of Before Operation.....	14-2
14.2	Setting CUnet communication specifications.....	14-3
14.3	Mounting.....	14-6
14.4	Wiring	14-7
14.4.1	Wiring for Power Supply and Communication	14-7
14.4.2	Wiring for Input and Output.....	14-9
14.4.3	Wiring Example of CUnet Communication Line	14-10
14.5	Global Memory (GM).....	14-11
14.6	Software	14-11
14.7	Global Memory (GM) Map	14-12
14.8	Attached Function	14-13
15	Action Explanation.....	15-1
15.1	Standard Function	15-1
15.1.1	Input Scaling Function	15-1
15.1.2	Output Scaling Function	15-1
15.1.3	Sensor Correction Factor.....	15-1
15.1.4	Sensor Correction.....	15-2
15.2	Attached Function	15-3
15.2.1	Warm-up Display	15-3
15.2.2	Power Failure Countermeasure	15-3
15.2.3	Self-Diagnosis	15-3
15.2.4	Automatic Cold Junction Temperature Compensation	15-3
15.2.5	PV Filter Time Constant Setting	15-3
15.2.6	Moving Average Count Setting	15-4
15.2.7	Overscale	15-4
15.2.8	Underscale	15-4
15.2.9	Sensor Error	15-4
15.2.10	Cold Junction Error	15-5
15.2.11	ADC Error	15-5
15.2.12	Contact Switching Total Number of Times.....	15-5
15.2.13	Error History	15-6
16	Maintenance.....	16-1
17	Specifications	17-1
17.1	Standard Specifications.....	17-1
17.2	Optional Specifications.....	17-11
18	Troubleshooting.....	18-1
18.1	Host Communication	18-1
18.2	CUnet Communication	18-2

18.3	PV Reading Value	18-2
18.4	Status Flag 1	18-3
18.5	Status Flag 2	18-4

1 Overview

1.1 Overview of Analog I/O Module QAM1-4

This instrument is a 4 points analog I/O module.

A multi-point measurement system can be configured via a host computer or PLC.

A maximum of 16 instruments can be connected to the BUS, and a maximum of 64 points can be measured. One block connected to BUS is called "1 unit".

1.2 Description of Module

Analog I/O module with 4 points specifications.

Terminal block type or connector type with 4 individual I/O channels.

The following options are available.

- Power supply / communication option
 - With power supply / host communication function
 - With power supply / CUNet communication function

Depending on whether have the option, the panel design differs.

There is a triangle mark on the upper left of the panel, when the power supply / communication option is not available.

Terminal block type

QAM1-40T-□-□-□-□-□-□-□-□-□-□

No options

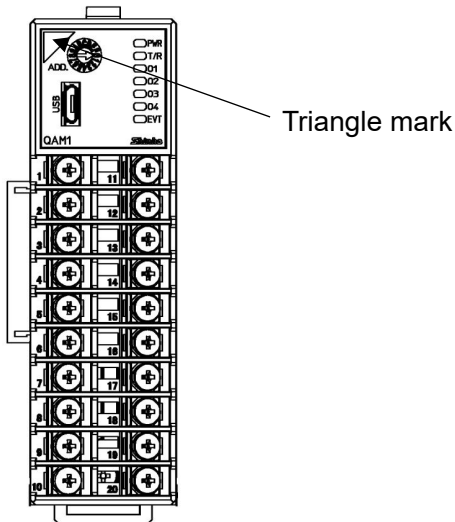

(Fig. 1.2-1)

QAM1-4PT-□-□-□-□-□-□-□-□-□-□ , QAM1-4CT-□-□-□-□-□-□-□-□-□-□

With power supply /
host communication function

With power supply /
CUNet communication function

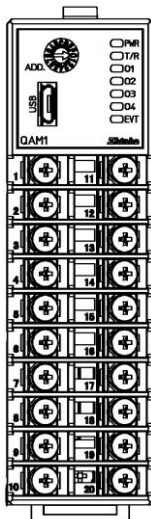

(Fig. 1.2-2)

1.3 System Configuration

1.3.1 Connecting to Host Computer

When connecting to the host computer, one analog I/O module QAM1-4P (with power supply / host communication function) is required for host communication.

The second and subsequent power lines to the control module are BUS-connected by the connector.

For the second and subsequent control modules, use the analog I/O module QAM1-40 (no power supply / communication option).

Maximum of 16 control modules can be connected.

Configuration example of host computer and QAM1-4P, QAM1-40

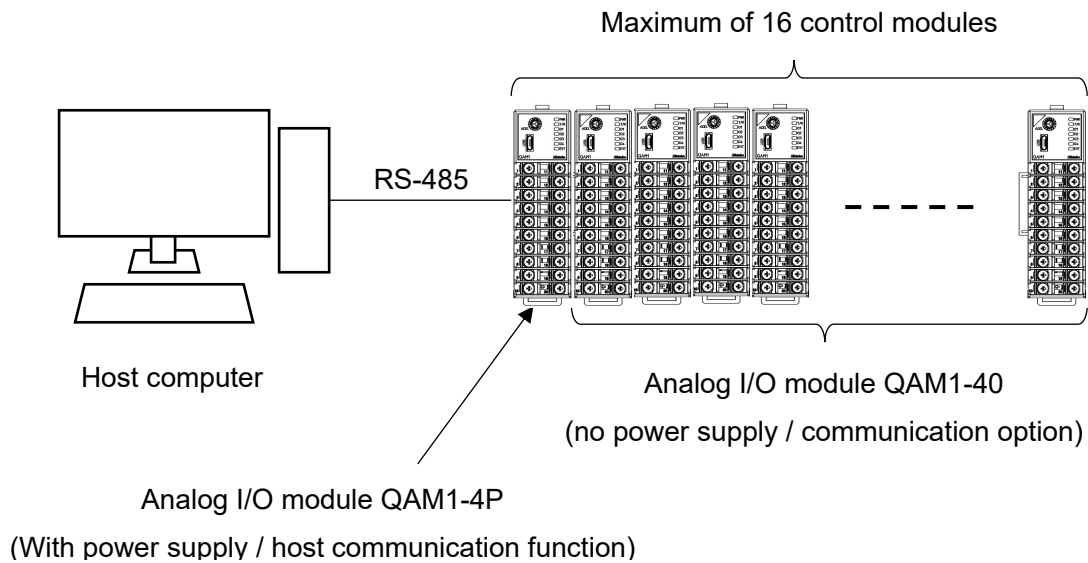

(Fig. 1.3.1-1)

A maximum of 16 units can be connected by connecting the communication expansion module QMC1s.

Refer to communication expansion module QMC1 instruction manual for detail.

Configuration example of host computer and QMC1, QAM1-40

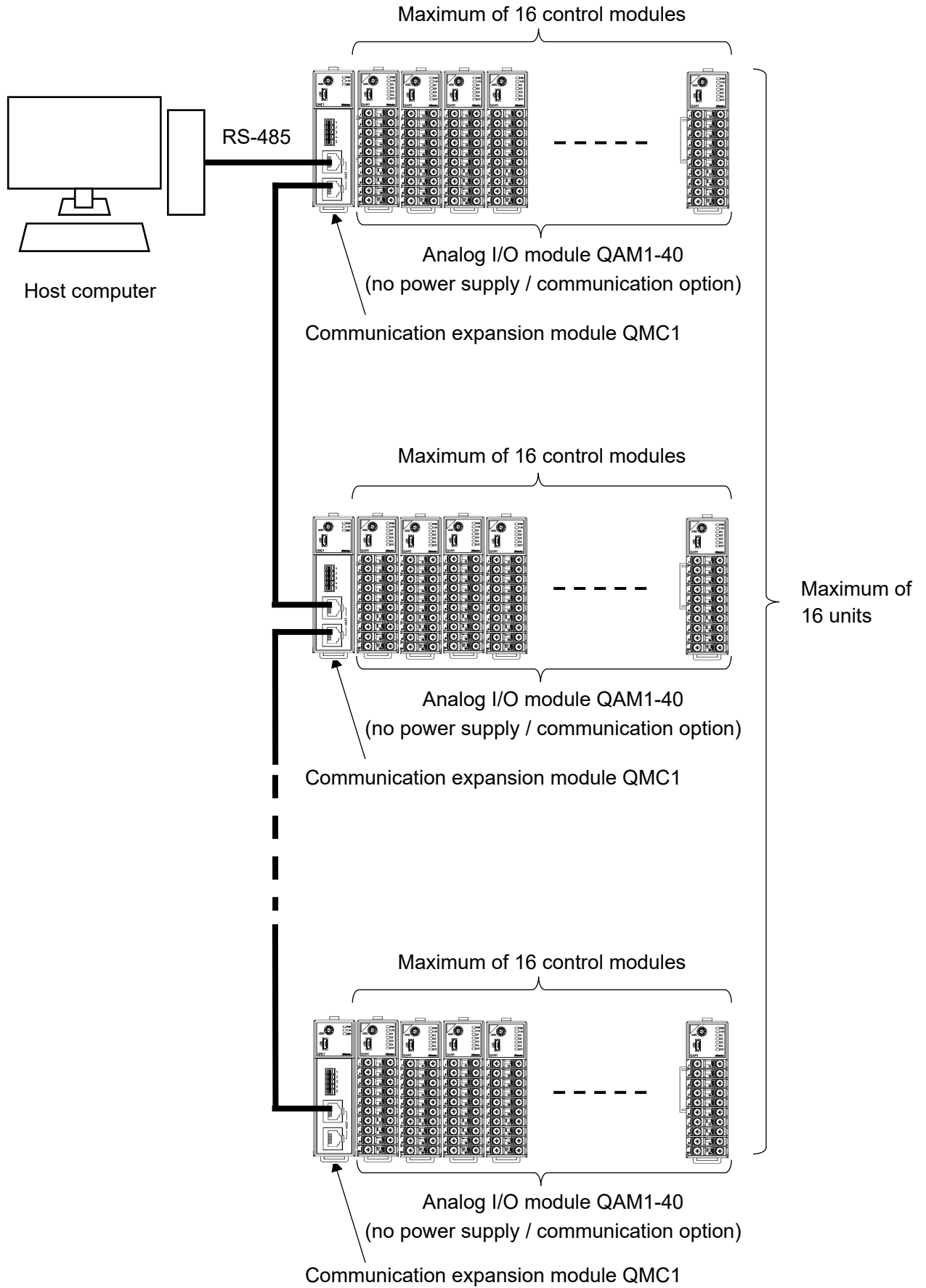

(Fig. 1.3.1-2)

1.3.2 Connecting to PLC

(1) When connecting to MELSEC Q, QnA series by Mitsubishi Electric Corporation

When connecting to the MELSEC Q, QnA series by Mitsubishi Electric Corporation, one control module QTC1-2P (with power supply / communication option) or QTC1-4P (with power supply / communication option) is required for host communication.

Use the SIF function (Smart InterFace, programless communication function) (P.13-1).

The second and subsequent power lines to the analog I/O module are BUS-connected by the connector.

For the second and subsequent control modules, use the analog I/O module QAM1-40 (no power supply / communication option).

Maximum of 16 control modules can be connected.

Configuration example of host computer and QTC1-4P, QAM1-40

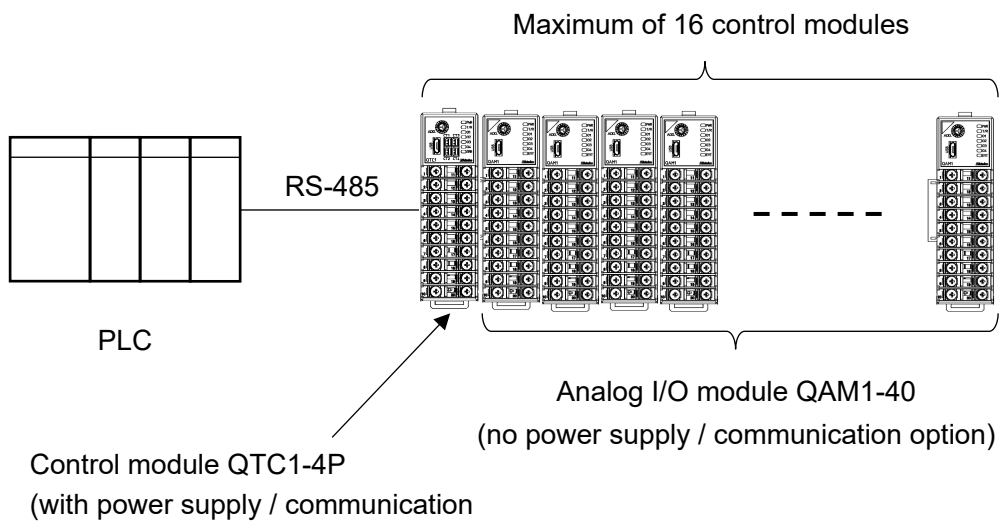

(Fig. 1.3.2-1)

- (2) When connecting to PLC by Mitsubishi Electric Corporation, PLC by OMRON Corporation and PLC by KEYENCE CORPORATION

When connecting to the PLC by Mitsubishi Electric Corporation, PLC by OMRON Corporation (*) and PLC by KEYENCE CORPORATION, one communication expansion module QMC1 is required for host communication per unit.

The power and communication lines to the analog I/O module are BUS-connected with the connector.

Use the analog I/O module QAM1-40 (no power supply / communication option).

Maximum of 16 control modules can be connected.

(*): When connecting to an OMRON PLC with the SIF function of communication expansion module QMC1, the RS-485 communication type cannot be used.

Only RS-422A communication type can be connected.

Configuration example of PLC and QMC1, QAM1-40

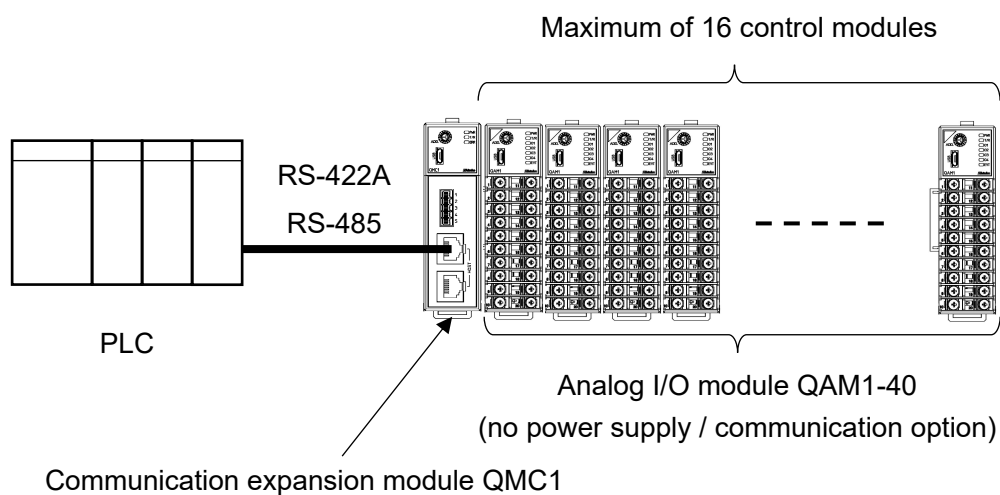

(Fig. 1.3.2-2)

A maximum of 16 units can be connected by connecting the communication expansion module QMC1s.

Refer to communication expansion module QMC1 instruction manual for detail.

Configuration example of PLC and QMC1, QAM1-40

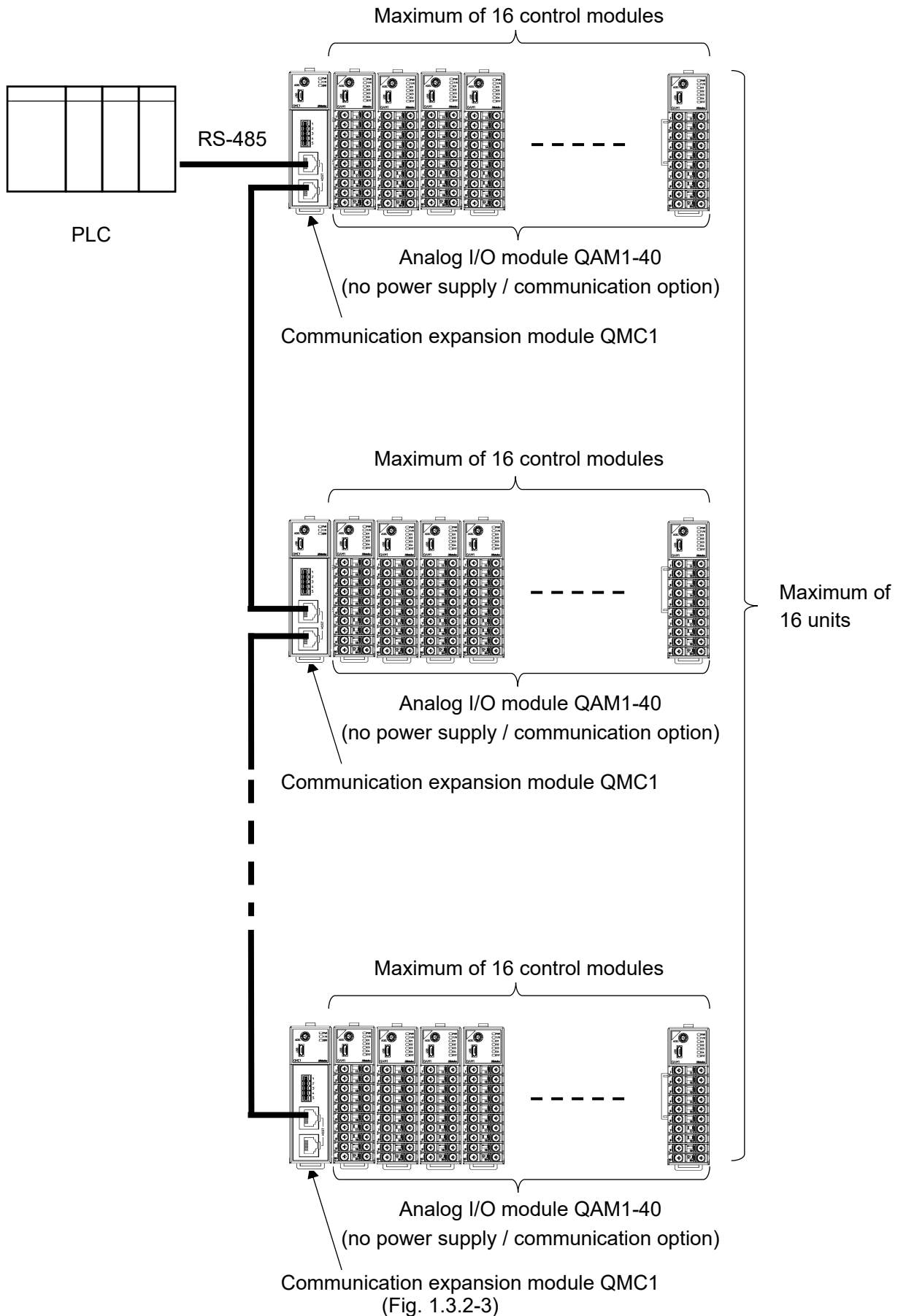

1.3.3 Connecting to CUnet

When connecting to CUnet, the analog I/O module QAM1-4C (with power supply / CUnet communication function) is required for CUnet communication.

Maximum of 64 control modules can be connected.

Configuration example of host computer (master board) and QAM1-4C

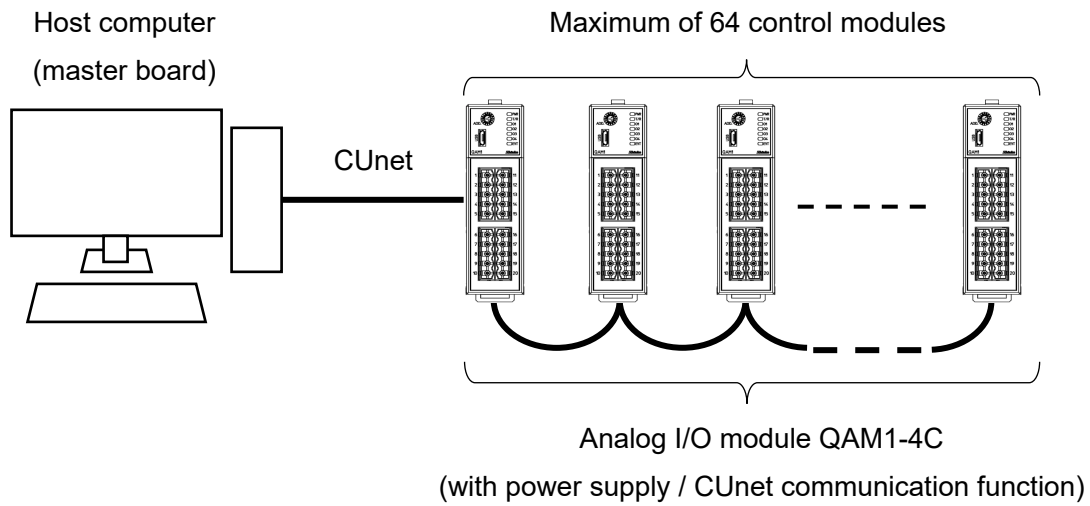

(Fig. 1.3.3-1)

1.4 Parameter Passing

1.4.1 Using the Analog I/O Module QAM1-4P (with power supply / host communication function)

When the analog I/O module QAM1-4P (with power supply / host communication function) is used, the parameter passing is as shown below.

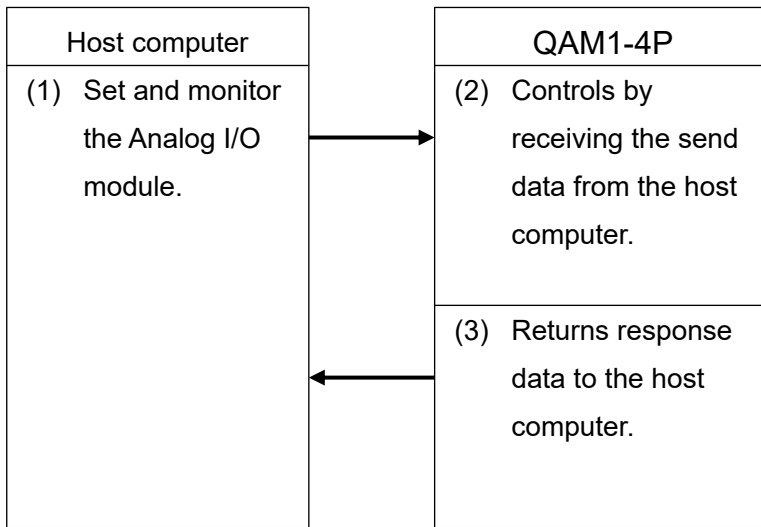

(Fig. 1.4-1)

1.4.2 Using the Communication Expansion Module QMC1

When the communication expansion module QMC1 is used, the parameter passing is as shown below.

Refer to the communication expansion module QMC1 instruction manual for detail.

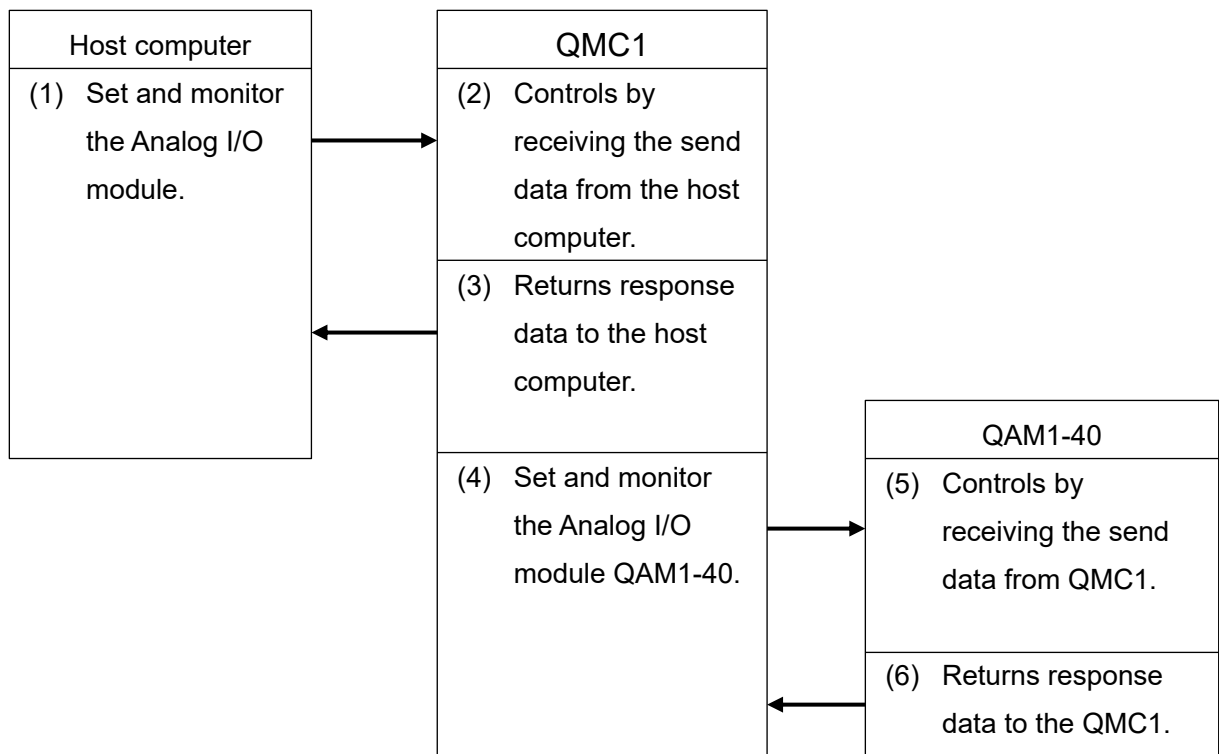

(Fig. 1.4-2)

2 Model

2.1 Model

QAM1-4	<input type="checkbox"/>	<input type="checkbox"/>	<input type="checkbox"/>	<input type="checkbox"/>	<input type="checkbox"/>	<input type="checkbox"/>	<input type="checkbox"/>	<input type="checkbox"/>	<input type="checkbox"/>	<input type="checkbox"/>	
Power supply / communication option	0										No option
	P										With power supply / host communication function
	C										With power supply / CUNet communication function
Wiring type	T										Terminal block type
	C										Connector type
I/O type (*)	-0										Input 4 points
	-1										Output 4 points
	-2										I/O 4 points each
Analog output 1			<input type="checkbox"/>								Refer to output code table
Analog output 2				<input type="checkbox"/>							
Analog output 3					<input type="checkbox"/>						
Analog output 4						<input type="checkbox"/>					
Analog input 1							<input type="checkbox"/>				Refer to input code table
Analog input 2								<input type="checkbox"/>			
Analog input 3									<input type="checkbox"/>		
Analog input 4										<input type="checkbox"/>	

(*): For input-only type, output code selection is invalid.

For output-only type, input code selection is invalid.

Output code table

Output code	Output type
A	DC current output 4 to 20 mA DC
0	DC current output 0 to 20 mA DC
V	DC voltage output 0 to 1 V DC
1	DC voltage output 0 to 5 V DC
2	DC voltage output 1 to 5 V DC
3	DC voltage output 0 to 10 V DC
N (*)	No output

(*): Output code N is valid only when I/O type 0 (input 4 points) is selected.

Input code table

Input code	Input type		Range
M	Thermocouple input	K	-200 to 1370 °C
		K	-200.0 to 400.0 °C
		J	-200 to 1000 °C
		R	0 to 1760 °C
		S	0 to 1760 °C
		B	0 to 1820 °C
		E	-200 to 800 °C
		T	-200.0 to 400.0 °C
		N	-200 to 1300 °C
		PL-II	0 to 1390 °C
		C (W/Re5-26)	0 to 2315 °C
		K	-328 to 2498 °F
		K	-328.0 to 752.0 °F
		J	-328 to 1832 °F
		R	32 to 3200 °F
		S	32 to 3200 °F
		B	32 to 3308 °F
		E	-328 to 1472 °F
		T	-328.0 to 752.0 °F
		N	-328 to 2372 °F
	PL-II	32 to 2534 °F	
	C (W/Re5-26)	32 to 4199 °F	
	RTD input	Pt100	-200.0 to 850.0 °C
		Pt100	-328.0 to 1562.0 °F
	DC voltage input	0 to 1 V DC	-32768 to 32767(*1)
	DC current input	4 to 20 mA DC (External receiving resistor)	-32768 to 32767(*1)
0 to 20 mA DC (External receiving resistor)		-32768 to 32767(*1)	
A	DC current input	4 to 20 mA DC (Built-in receiving resistor)	-32768 to 32767(*1)
		0 to 20 mA DC (Built-in receiving resistor)	-32768 to 32767(*1)
V	DC voltage input	0 to 5 V DC	-32768 to 32767(*1)
		1 to 5 V DC	-32768 to 32767(*1)
		0 to 10 V DC	-32768 to 32767(*1)
N (*2)	No input		

(*1): Scaling possible (16-bit signed range)

(*2): Input code N is valid only when I/O type 1 (output 4 points) is selected.

2.2 How to Read the Model Label

The model label is attached to the right side of this instrument.

Terminal block type

No power supply / communication option

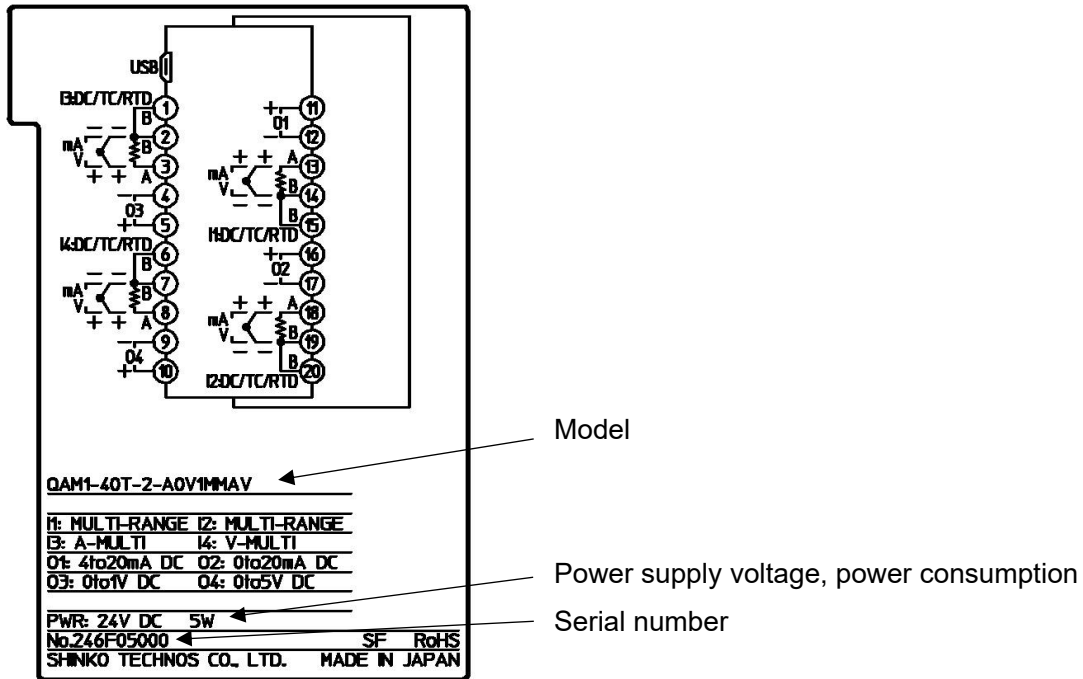

(Fig. 2.2-1)

With power supply / host communication function

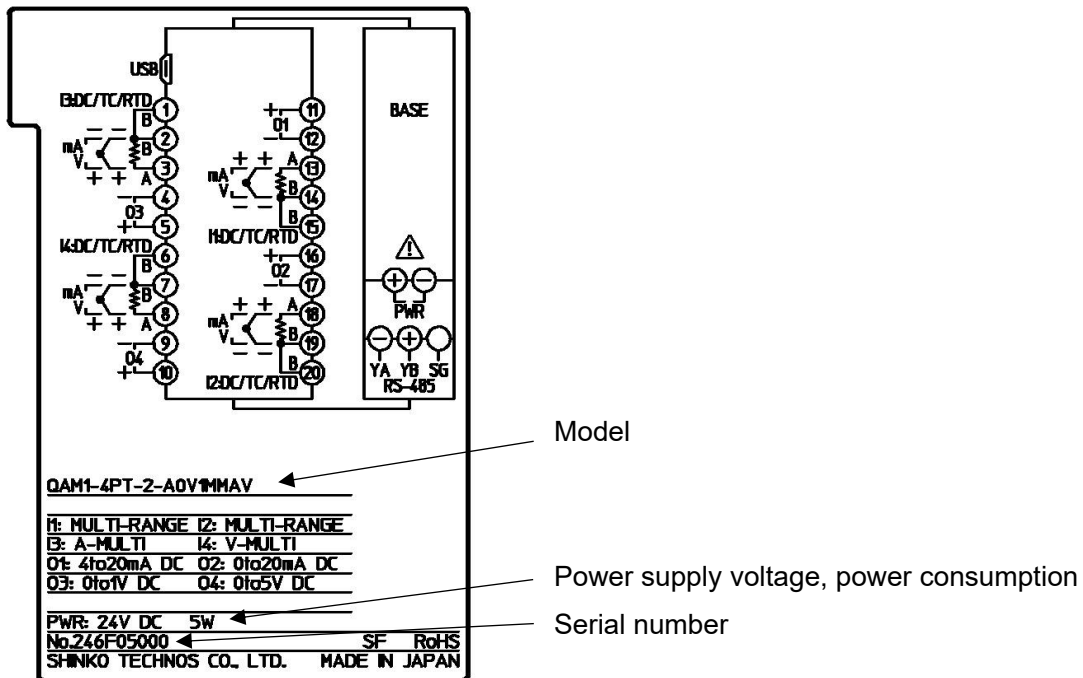

(Fig. 2.2-2)

With power supply / CUnet communication function

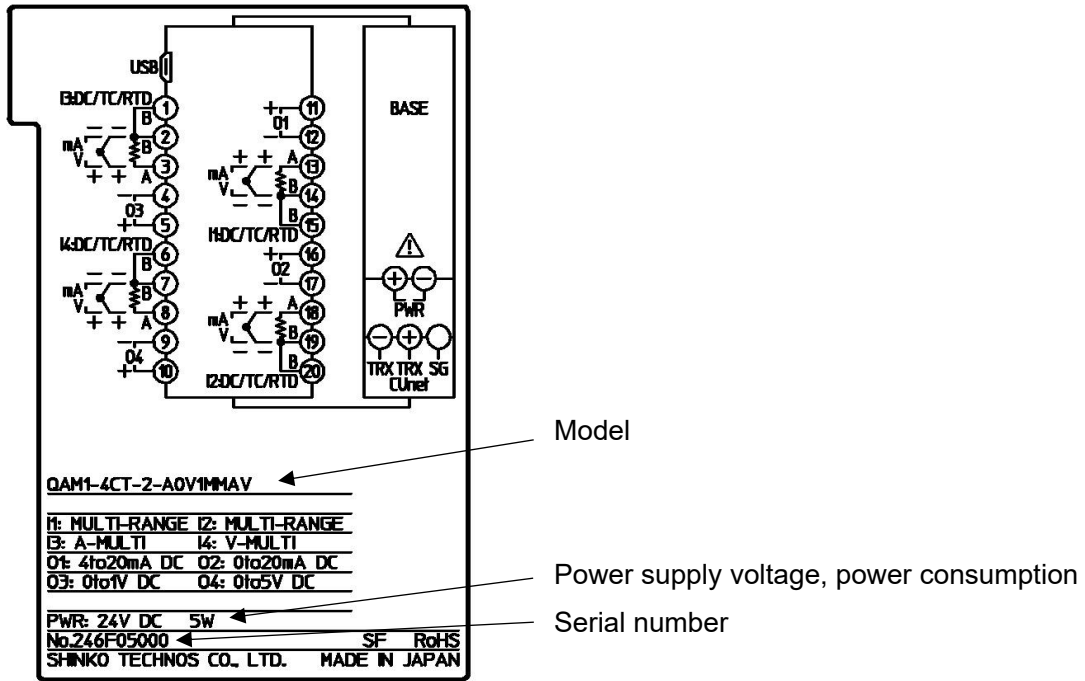

(Fig. 2.2-3)

Connector type

No power supply / communication option

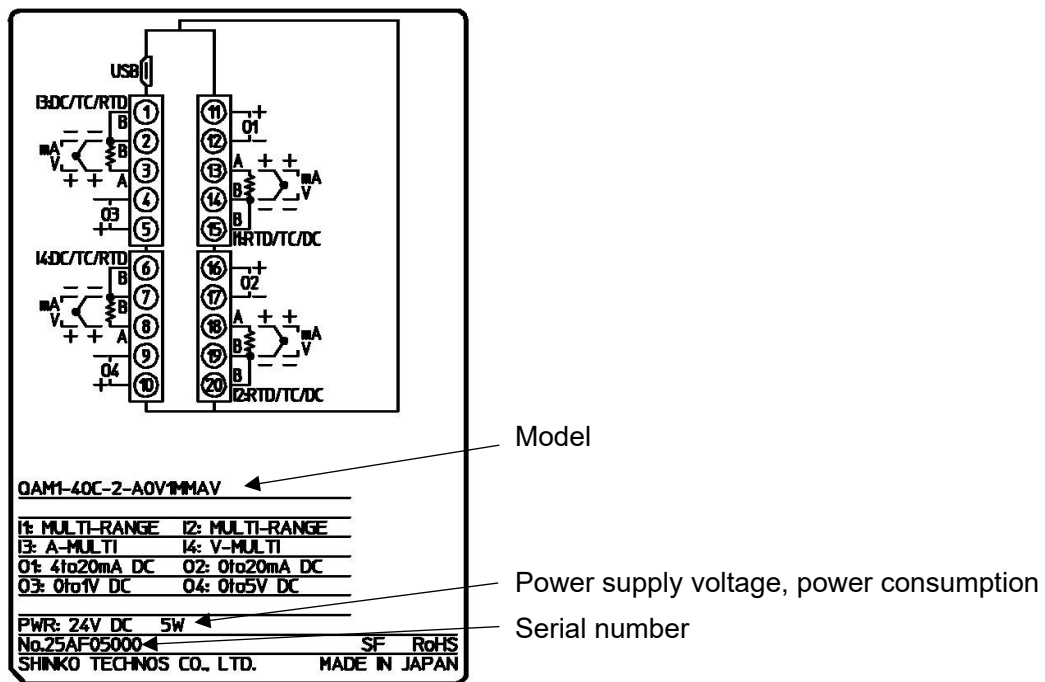

(Fig. 2.2-4)

With power supply / host communication function

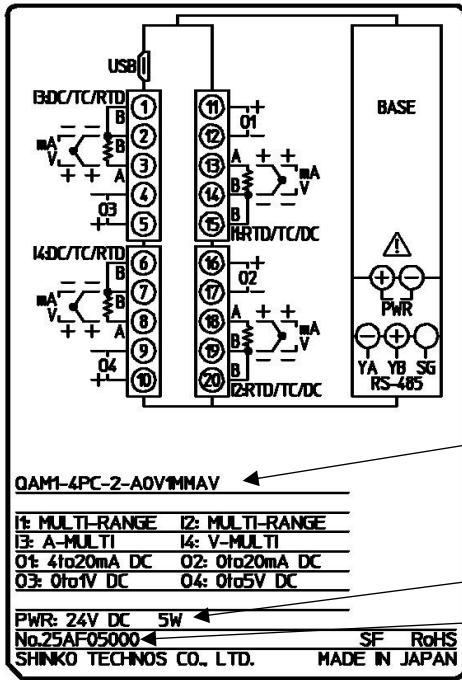

Model

Power supply voltage, power consumption

Serial number

(Fig. 2.2-5)

With power supply / CUnet communication function

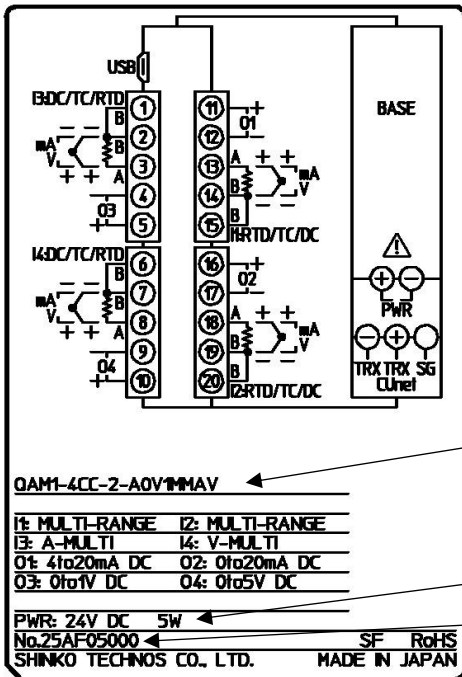

Model

Power supply voltage, power consumption

Serial number

(Fig. 2.2-6)

3 Name and Functions

3.1 Analog I/O Module QAM1-4

Terminal block type

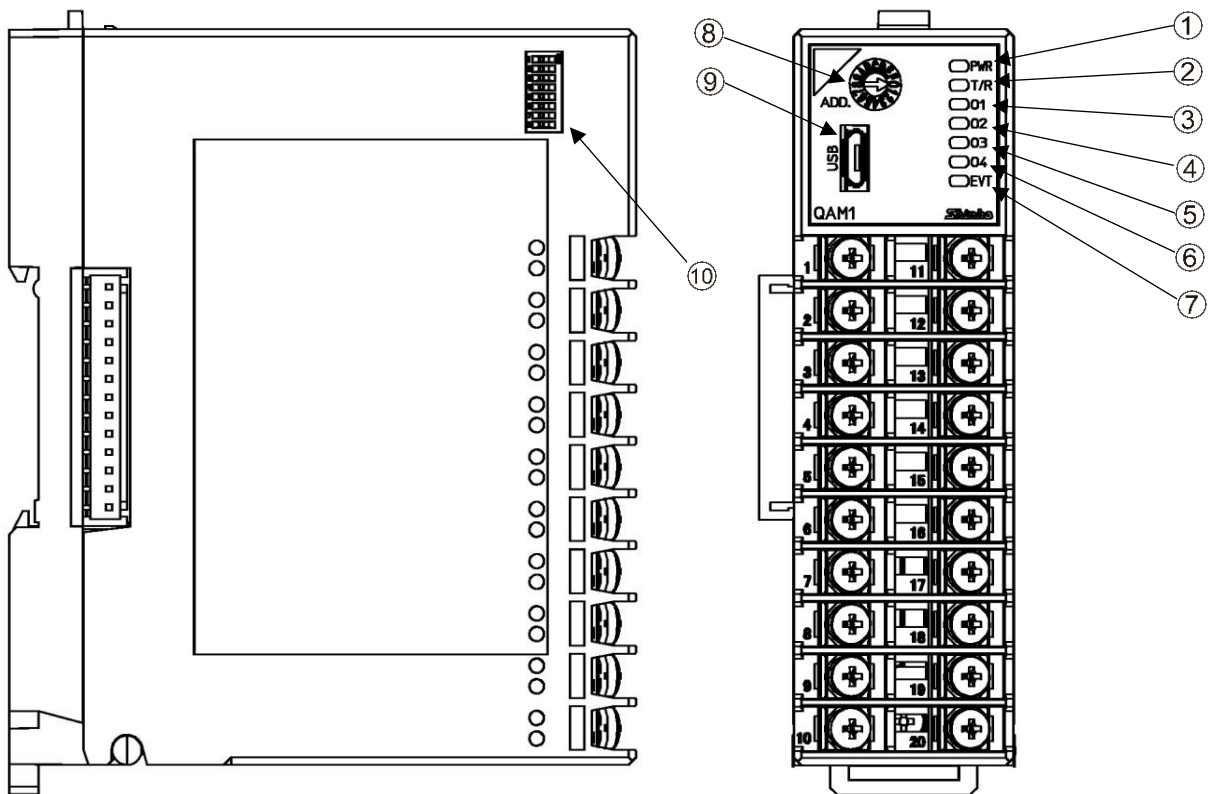

Base part

No power supply / communication option

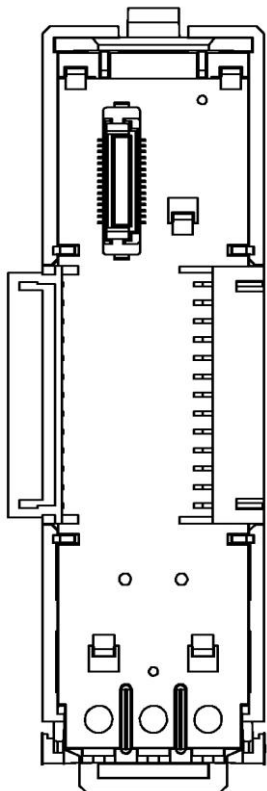

With power supply / host communication option

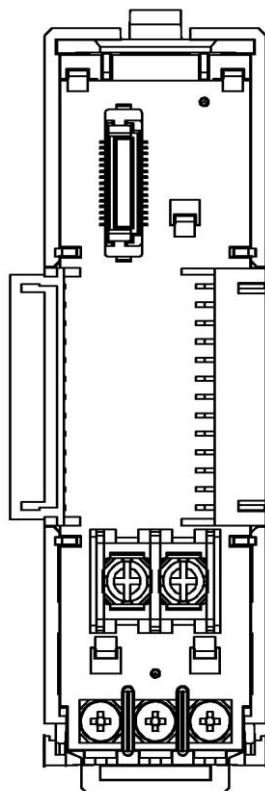

With power supply / CUnet communication option

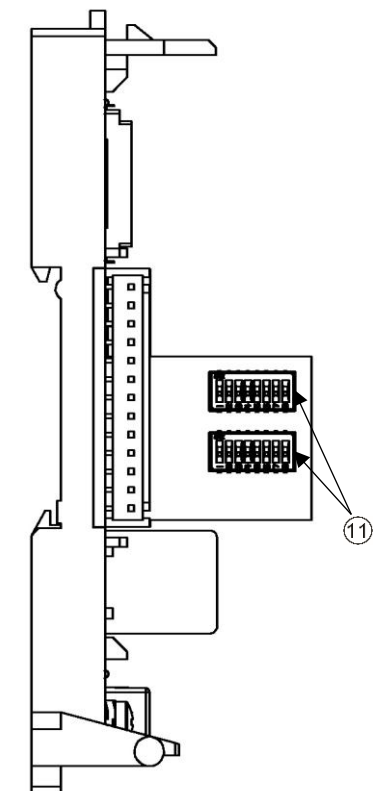

(Fig. 3.1-1)

Connector type

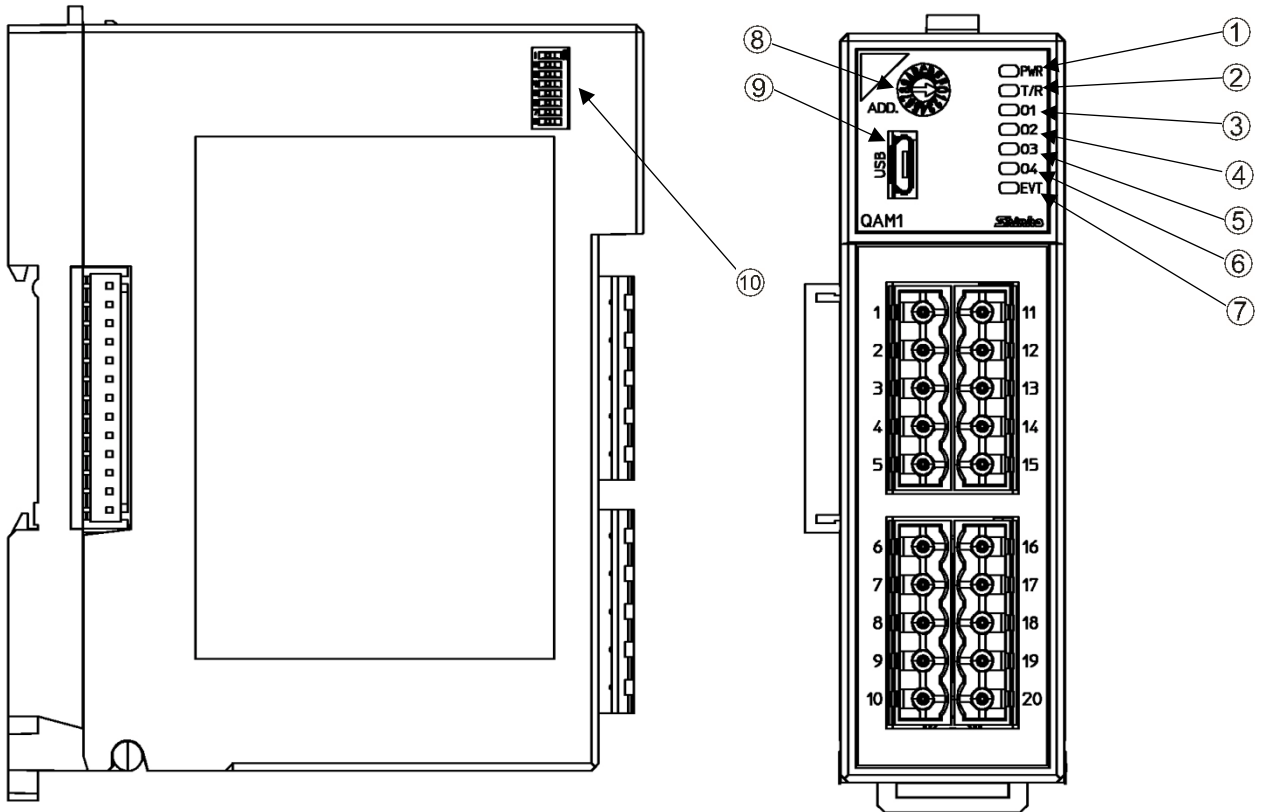

Base part

No power supply / communication option

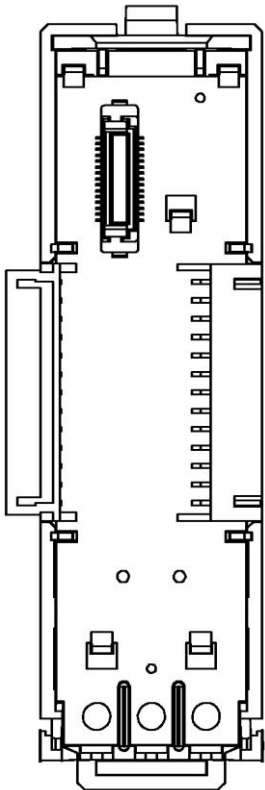

With power supply / host communication option

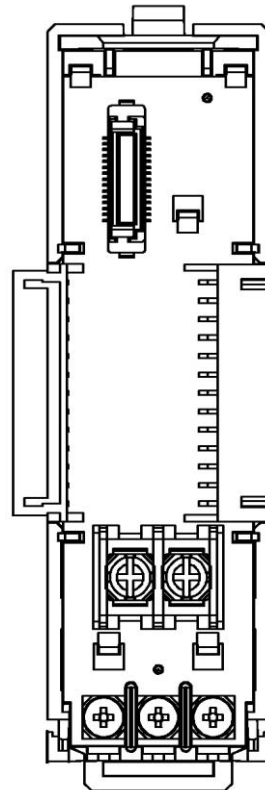

With power supply / CUNet communication option

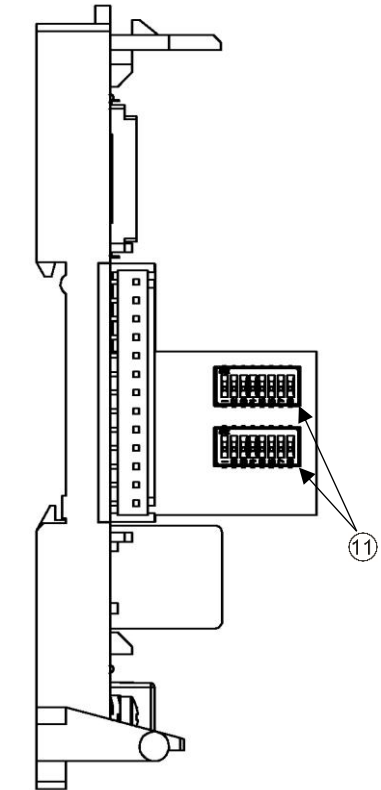

(Fig. 3.1-2)

Operation indicator

No.	Symbol (color)	Name and Function
①	PWR (Green)	<p>Power indicator</p> <ul style="list-style-type: none"> • Lights off (always): No power supply to the instrumen • Lights up (always): Power supply to the instrumen • Flashing for 500 ms (3 seconds): Warming up the instrument • Flashing for 500 ms (always): Internal failure of the instrument [When non-volatile IC memory error or ADC (internal circuit) error]
②	T/R (Yellow)	<p>Communication indicator</p> <ul style="list-style-type: none"> • Lights off (always): Communication error (no response) or USB communication • Flashing (slow): Communication error (reception error) • Flashing (fast): Communication is normal
③	O1 (Green)	<p>Analog output 1 indicator</p> <p>Always lights off</p>
④	O2 (Green)	<p>Analog output 2 indicator</p> <p>Always lights off</p>
⑤	O3 (Green)	<p>Analog output 3 indicator</p> <p>Always lights off</p>
⑥	O4 (Green)	<p>Analog output 4 indicator</p> <p>Always lights off</p>
⑦	EVT (Red)	<p>Event indicator</p> <ul style="list-style-type: none"> • Flashing for 500 ms: Sensor error (overscale, underscale) • Flashing for 250 ms: Sensor error (input disconnection) or power is supplied from the computer by USB bus power

Switch and connector

No.	Symbol	Name and Function
⑧	ADD.	<p>Module address setting rotary switch</p> <p>Rotary switch for module address selection.</p> <p>The module address is the value of the selected rotary switch plus one.</p>
⑨	USB	<p>Console communication connector</p> <p>Connector for console communication tool cable.</p>
⑩		<p>Communication specification setting dip switch</p> <p>DIP switch for setting communication specifications.</p> <p>Set the communication specifications such as communication speed, data bit, parity, stop bit and communication protocol.</p>
⑪		<p>CUnet communication specification setting dip switch</p> <p>DIP switches for setting CUnet communication specifications.</p> <p>Set the station address, communication speed, master address, and number of occupied (OWN) items.</p>

4 Procedure Before Starting Operation

The procedure up to the start of operation when connecting to a host computer is shown below.

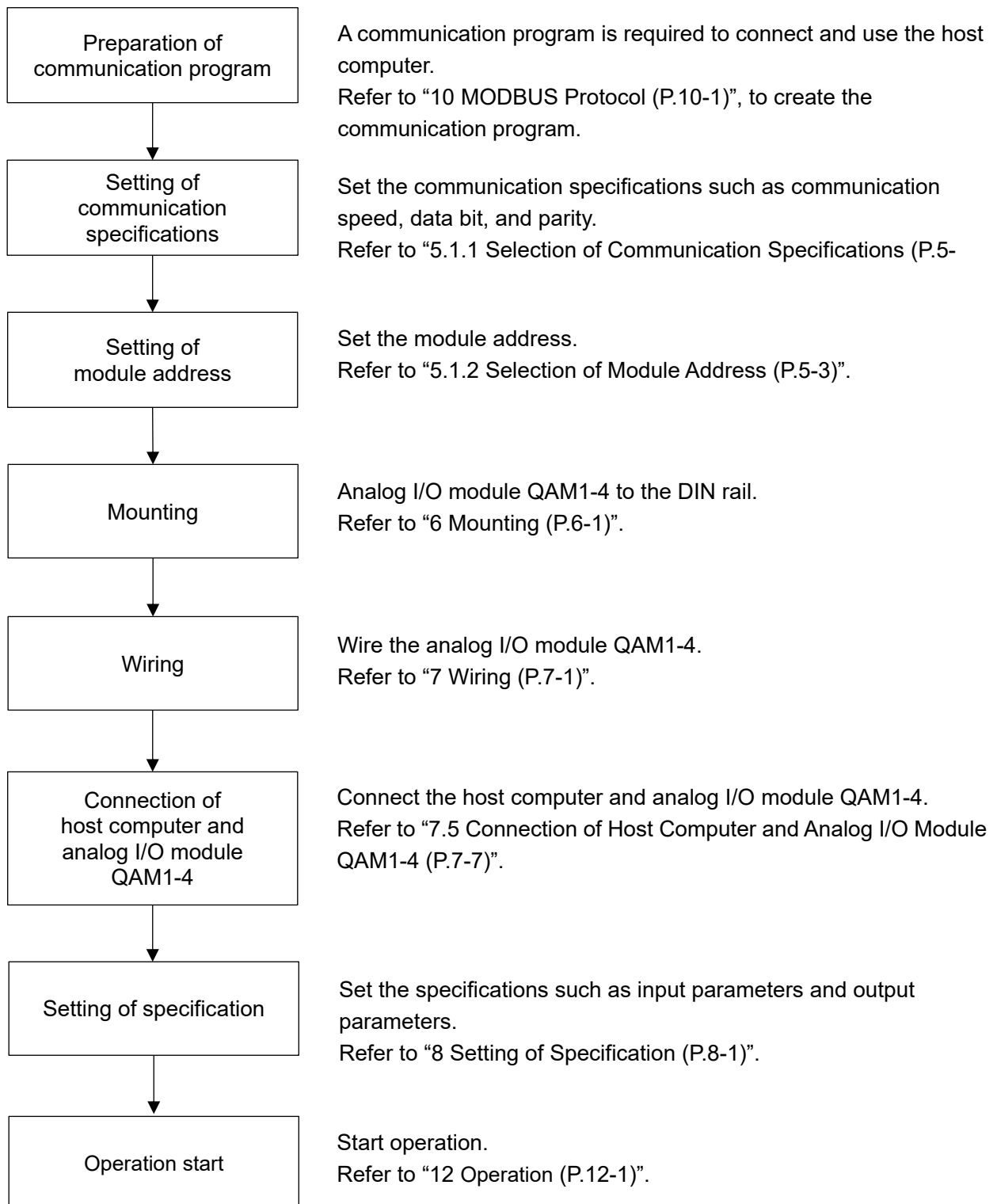

(Fig. 4-1)

5 Communication Parameter Setting

5.1 Communication Parameter Setting

5.1.1 Selection of Communication Specifications



Caution

When connecting to the communication expansion module QMC1, the communication specification selection is not required.

Use it in the factory default (all OFF).

Use the communication specification setting dip switch on the left side of the instrument to set communication specifications.

Terminal block type

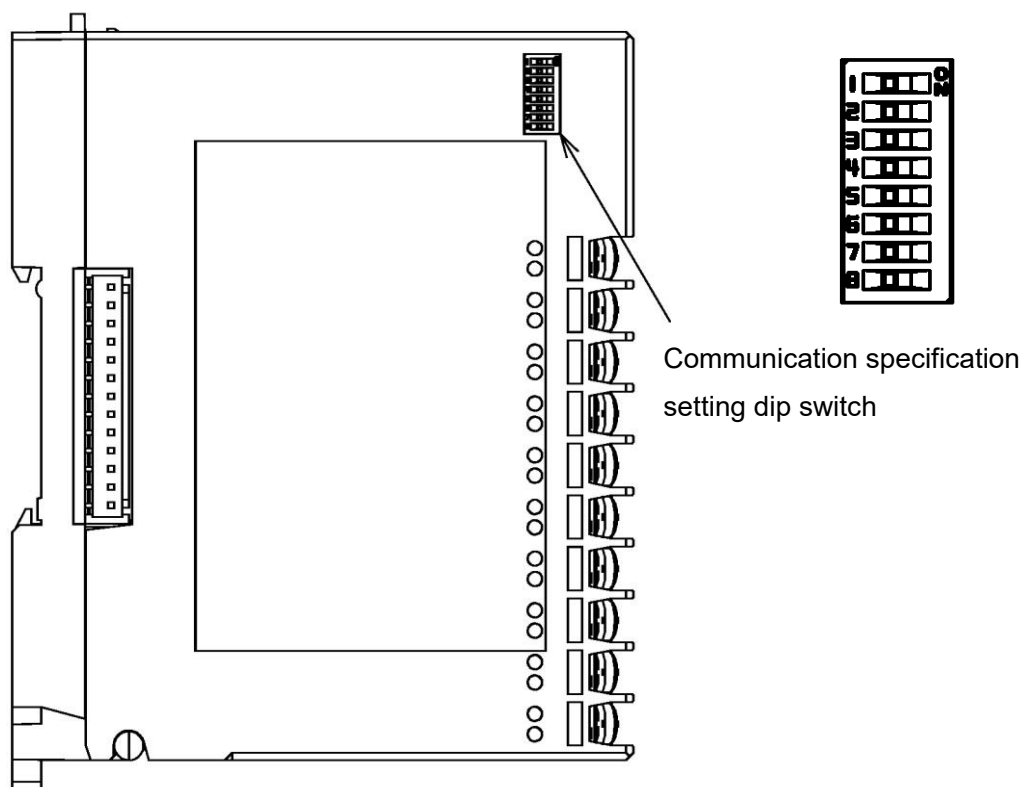

(Fig. 5.1.1-1)

Connector type

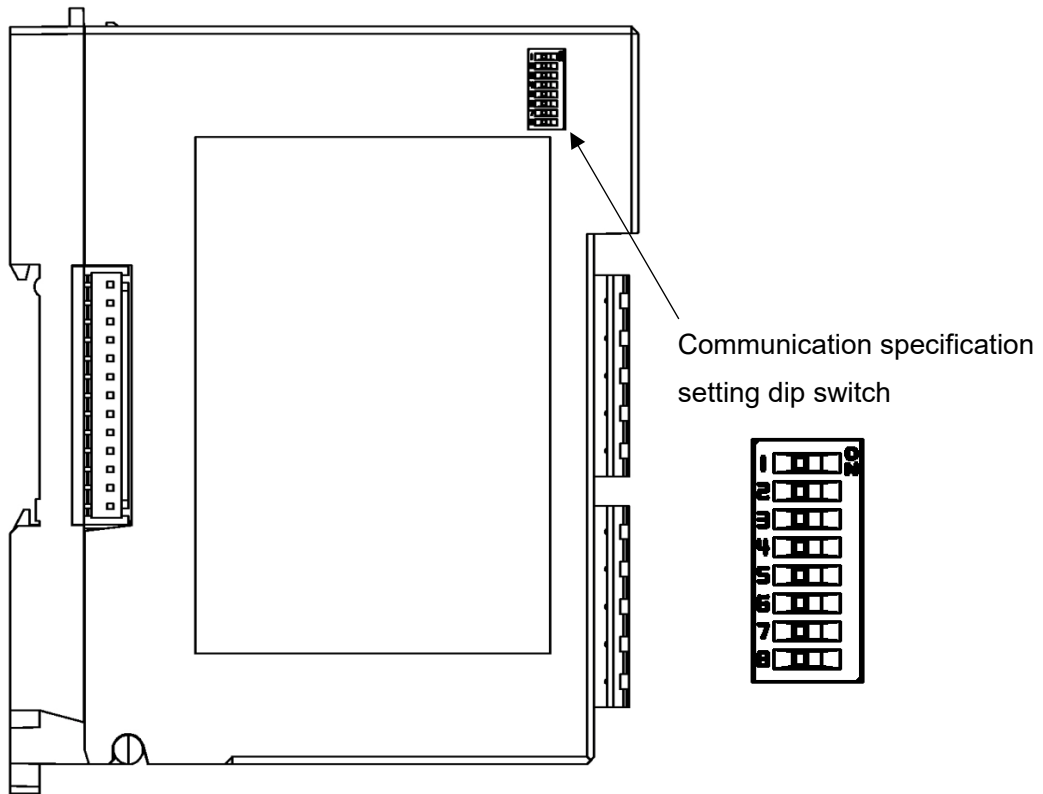

(Fig. 5.1.1-2)

Set the communication speed, data bit, parity, and stop bit.

The factory defaults are as follows.

- Communication speed
 - With power supply / host communication option: 57600 bps
 - With power supply / CUnet communication option: 38400 bps
- Data bit: 8 bits
- Parity: Even
- Stop bit: 1 bit

(1) Setting of communication speed

Communication specification setting dip switch		Communication speed
1	2	
OFF	OFF	57600 bps
ON	OFF	38400 bps
OFF	ON	19200 bps
ON	ON	9600 bps

(2) Setting of data bit, parity and stop bit

Communication specification setting dip switch			Data bit, parity and stop bit
3	4	5	
OFF	OFF	OFF	8 bits, Even, 1 bit
ON	OFF	OFF	8 bits, Even, 2 bits
OFF	ON	OFF	8 bits, Odd, 1 bit
ON	ON	OFF	8 bits, Odd, 2 bits
OFF	OFF	ON	8 bits, None, 1 bit
ON	OFF	ON	8 bits, None, 2 bits

Dip switches No.6, No.7 and No.8 does not use. Leave it OFF.

5.1.2 Setting of Module Address



Caution

When using the SIF function, module addresses should be set to consecutive numbers starting from 1. When using the MODBUS specification, any number between 0 to F (1 to 16) can be set.

The module addresses are set with the rotary switch.

Terminal block type

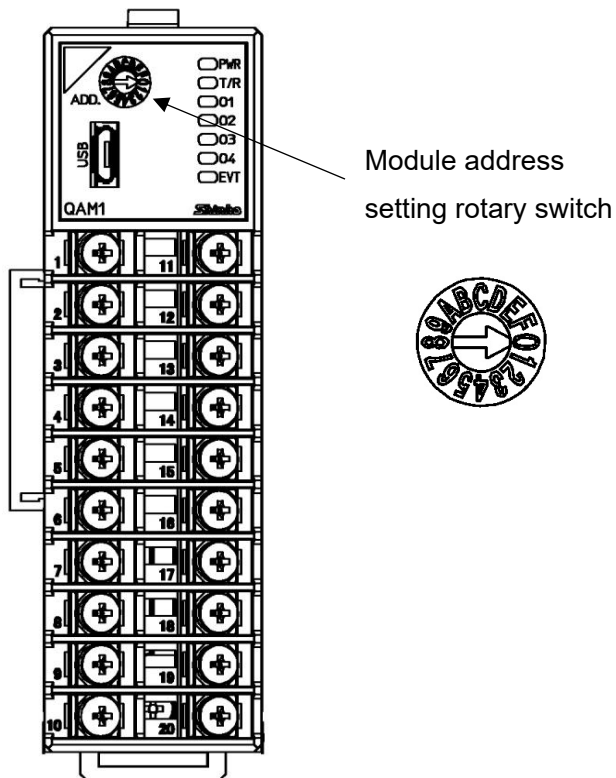

(Fig. 5.1.2-1)

Connector type

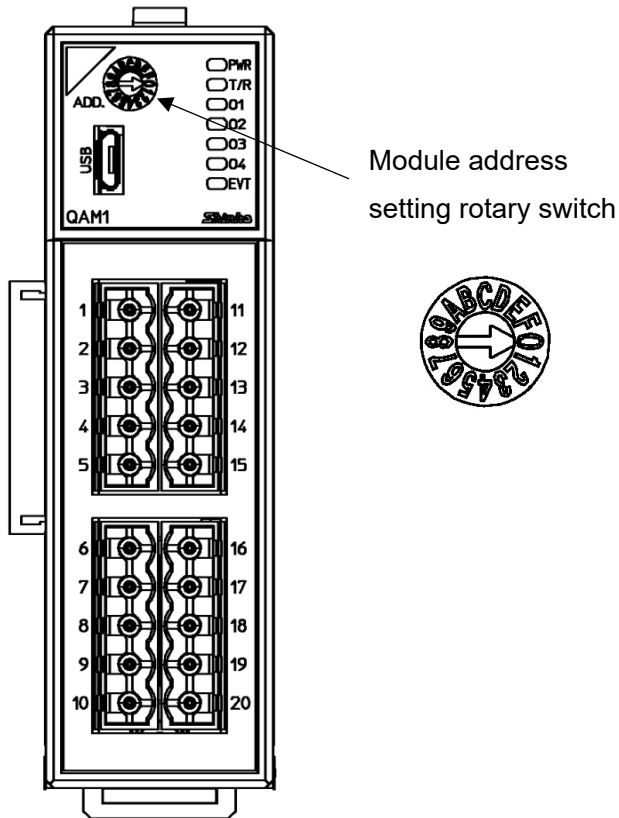

(Fig. 5.1.2-2)

Use a small flat-blade screwdriver to set the module addresses.

The value obtained by adding 1 to the value of the set rotary switch becomes the module addresses.

Module address: 0 to F (1 to 16)

Rotary switch	0	1		9	A	B		F
Module address	1	2		10	11	12		16

6 Mounting

⚠ Caution

- When mounting or removing this instrument, be sure to turn off the power supply to this instrument.
- Mount the DIN rail horizontally.
- This instrument fits the following DIN rails.

Top hat rail TH35 JIS C 2812-1988

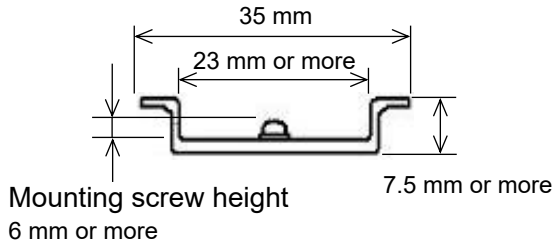

Width: 35 mm
Height: 7.5 mm or more
Groove width: 23 mm or more
DIN rail mounting screw height:
6 mm or more
(For DIN rail height 7.5 mm)

(Fig. 6-1)

- If this instrument is mounted in a position susceptible to vibration or shock, mount commercially available end plate at both ends of the instrument.
 - When installing, make sure that the orientation (upper and lower) of this instrument is correct.
 - When mounting or removing this instrument on the DIN rail, it must be tilted slightly
- Secure a space of 50 mm or more in the vertical direction of the instrument, considering the wiring space of the power supply/communication line and heat dissipation.

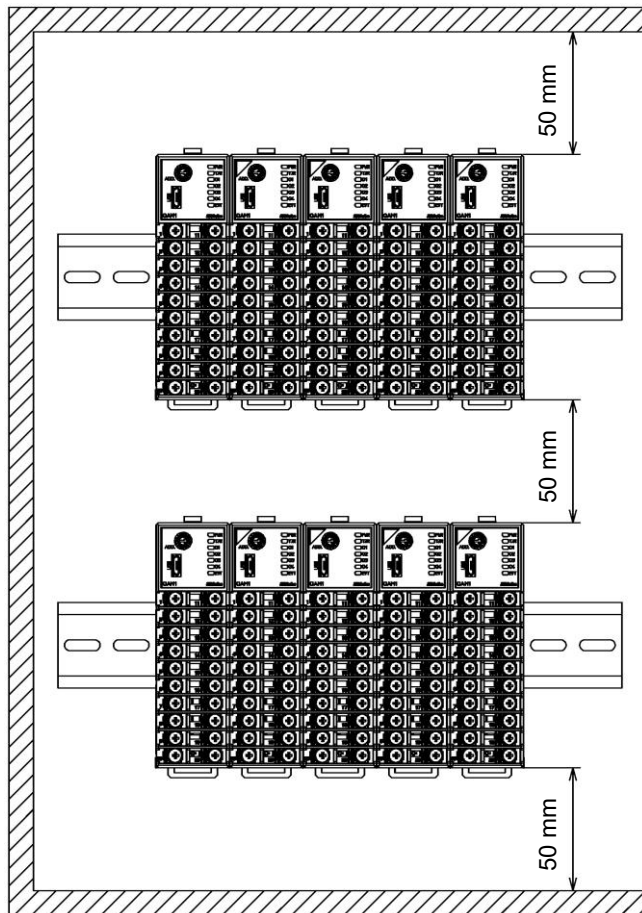

(Fig. 6-2)

6.1 Selection of Location

Ensure the mounting location corresponds to the following conditions:

- A minimum of dust, and an absence of corrosive gases
- No flammable, explosive gases
- No mechanical vibrations or shocks
- No exposure to direct sunlight, an ambient temperature of -10 to 50°C(14°F to 122°F) that does not change rapidly, and no icing
- An ambient non-condensing humidity of 35 to 85%RH
- No large capacity electromagnetic switches or cables through which large current is flowing
- No water, oil or chemicals or the vapors of these substances can come into direct contact with the unit.
- When installing this unit within a control panel, please note that ambient temperature of this unit – not the ambient temperature of the control panel – must not exceed 50°C (122°F). Otherwise the life of electronic components (especially electrolytic capacitor) may be shortened.
- * Avoid setting this instrument directly on or near flammable material even though the case of this instrument is made of flame-resistant resin.

6.2 External Dimensions (Scale: mm)

Analog I/O module QAM1-4

Terminal block type

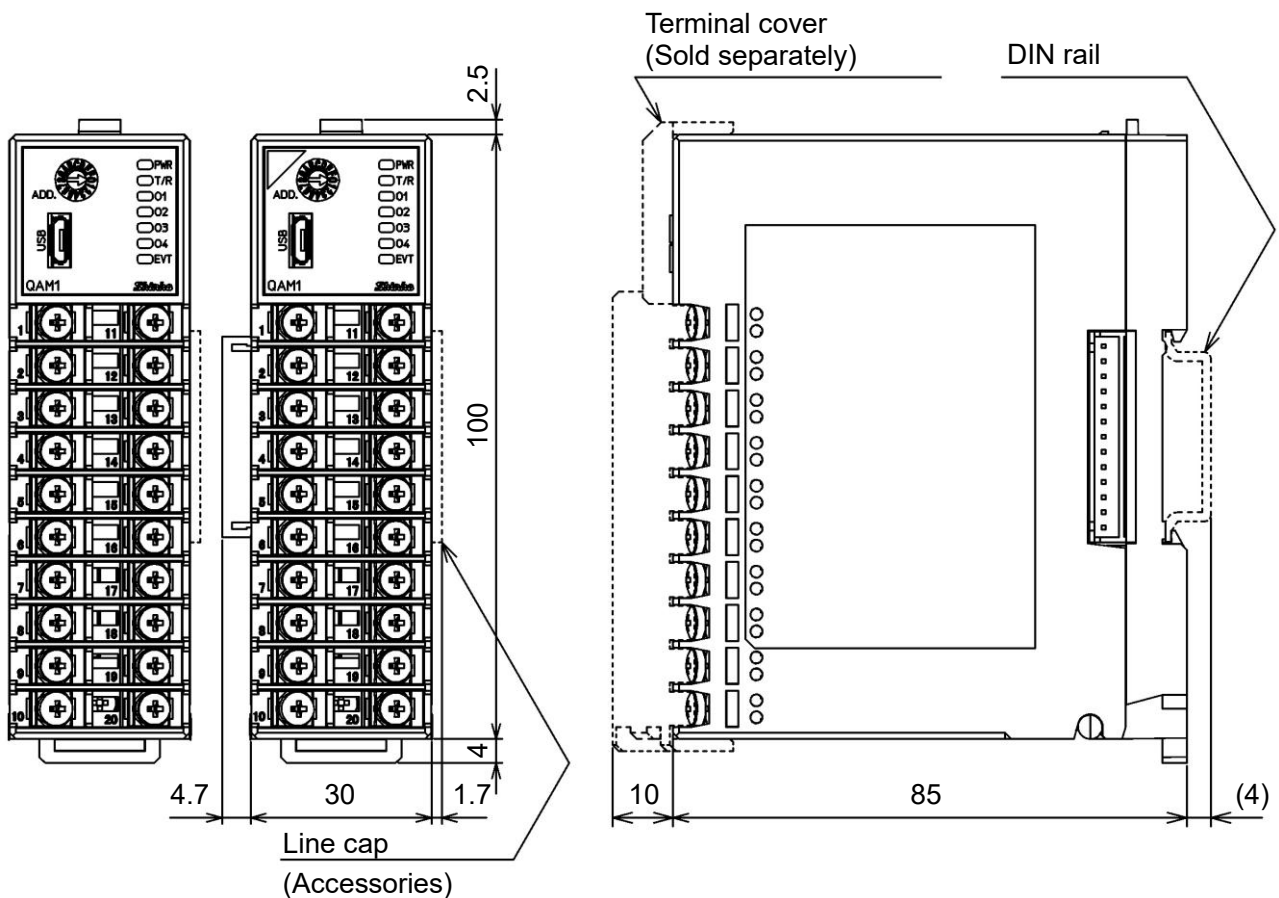

(Fig. 6.2-1)

Connector type

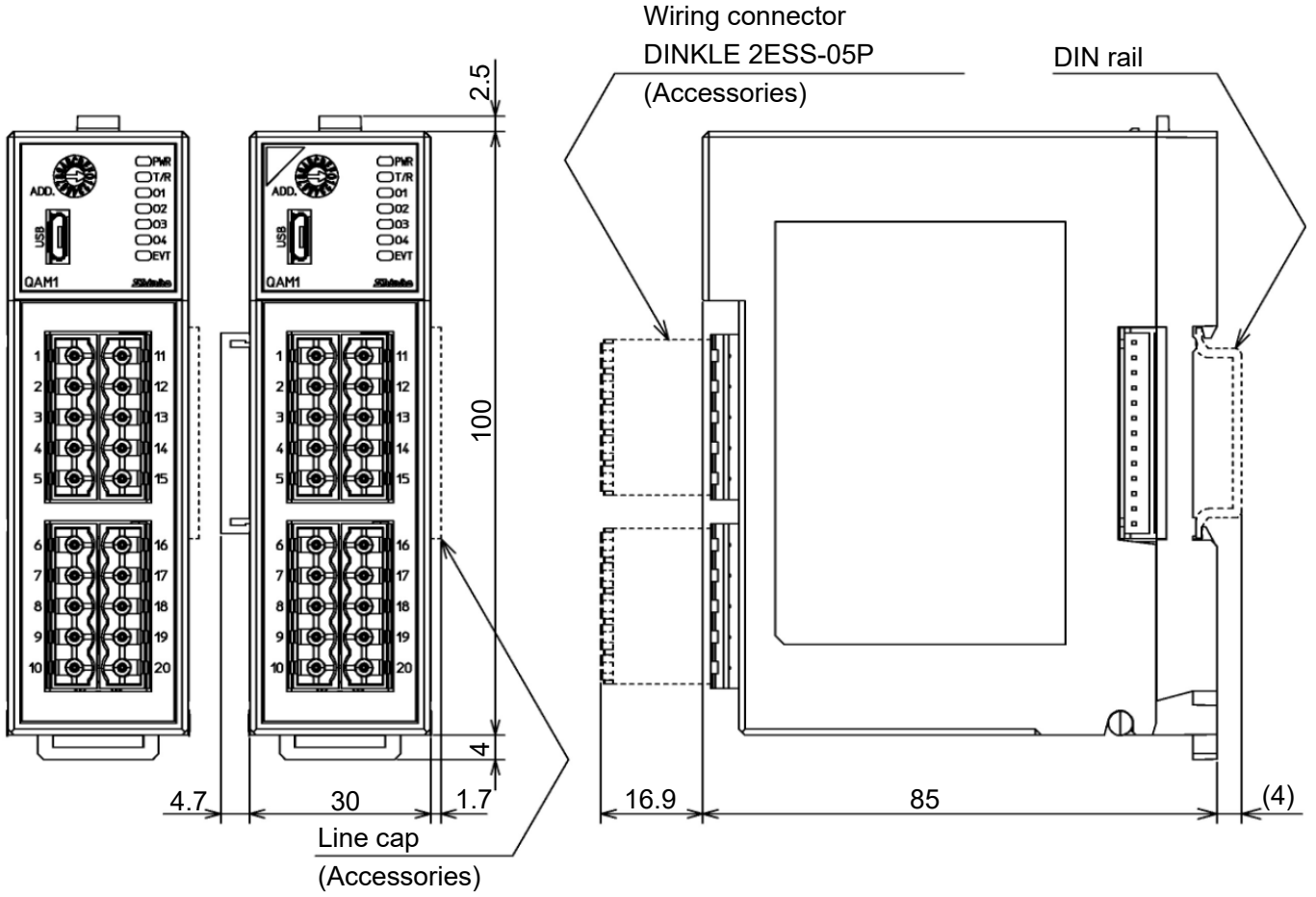

(Fig. 6.2-2)

6.3 Mounting

Mounting to the DIN rail

- ① Lower the lock lever of this instrument. (The lock lever of this instrument has a spring structure, but if lower it in the direction of the arrow until it stops, it will be locked in that position.)
- ② Hook the part ② of this instrument onto the top of the DIN rail.
- ③ Insert the lower part of this instrument with the part ② as a fulcrum.
- ④ Raise the lock lever of this instrument.

Make sure it is fixed to the DIN rail.

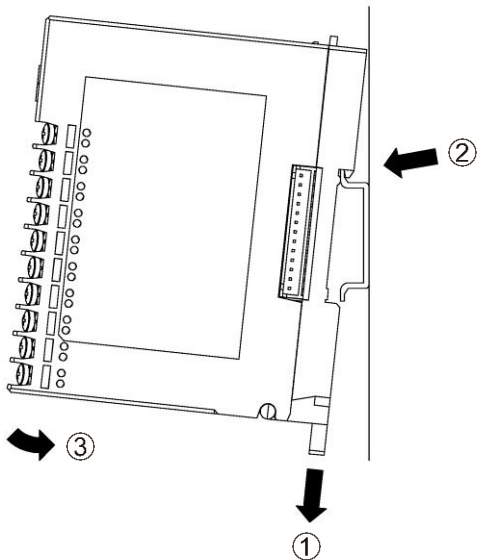

(Fig. 6.3-1)

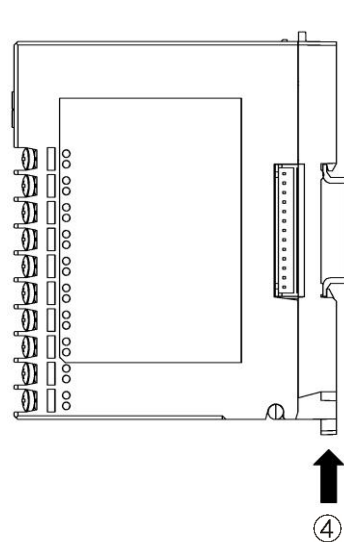

(Fig. 6.3-2)

Removal from the DIN rail

- ① Insert a flat blade screwdriver into the lock lever of this instrument and lower the lock lever until it stops.
- ② Remove this instrument from the DIN rail by lifting it from below.

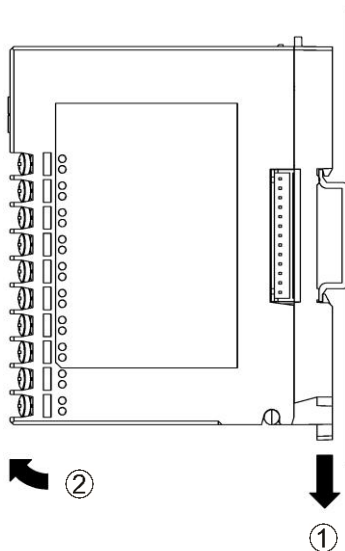

(Fig. 6.3-3)

Mounting multiple modules to the DIN rail

This section describes an example of mounting multiple modules on the DIN rail.

- ① Remove the line cap on the right side of the QAM1-4P.
- ② Lower the lock lever of the QAM1-40, and mounting the QAM1-40 to the DIN rail.
- ③ Slide the QAM1-40 to the left and connect the connectors to each other.
- ④ Raise the lock lever of the QAM1-40.

Make sure it is fixed to the DIN rail.

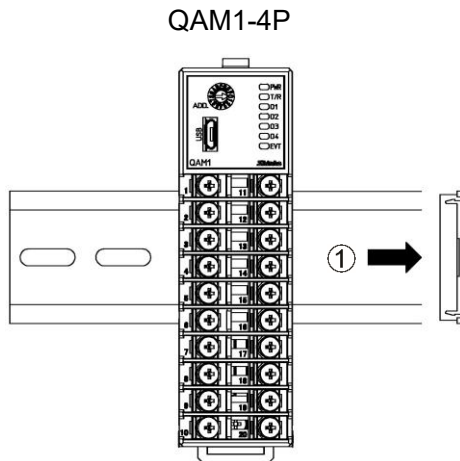

(Fig. 6.3-4)

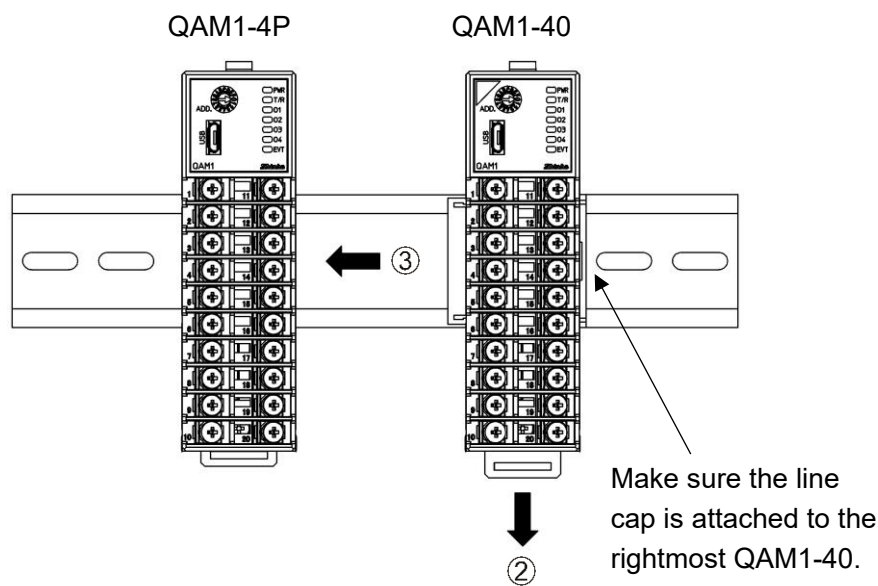

(Fig. 6.3-5)

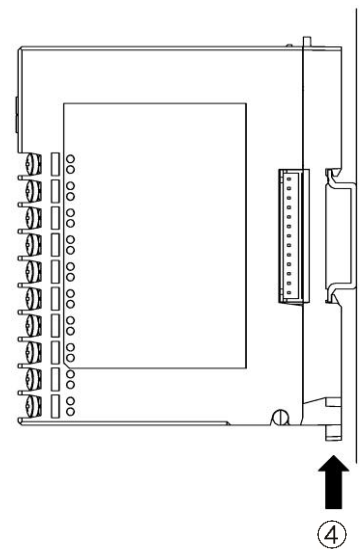

(Fig. 6.3-6)

This section describes an example of mounting communication expansion module QMC1 and analog I/O module QAM1-40 on the DIN rail.

- ① Remove the line cap on the right side of the QMC1.
- ② Lower the lock lever of the QAM1-40, and mounting the QAM1-40 to the DIN rail.
- ③ Slide the QAM1-40 to the left and connect the connectors to each other.
- ④ Raise the lock lever of the QAM1-40.

Make sure it is fixed to the DIN rail.

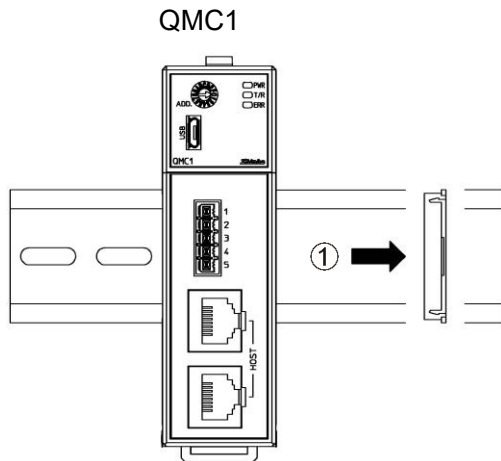

(Fig. 6.3-7)

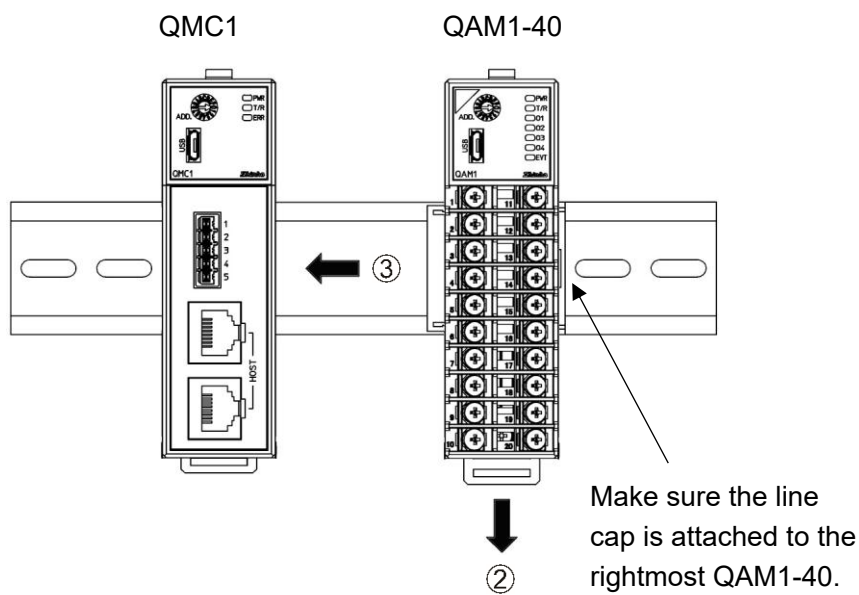

(Fig. 6.3-8)

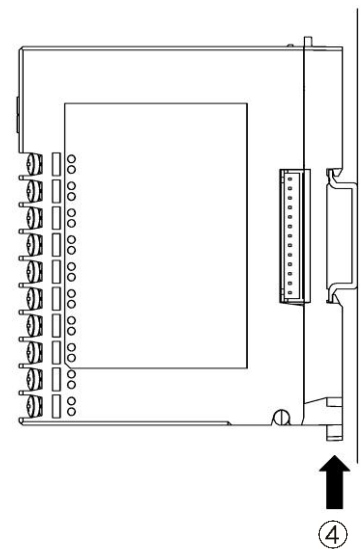

(Fig. 6.3-9)

Removal multiple modules from the DIN rail

This section describes an example of removing multiple analog I/O modules QAM1-40 on the DIN rail.

- ① Insert a flat blade screwdriver into the lock lever of the QAM1-40 and lower the lock lever until it stops.
- ② Slide QAM1-40 to the right side and disconnect it from the connector, then remove it from the DIN rail.

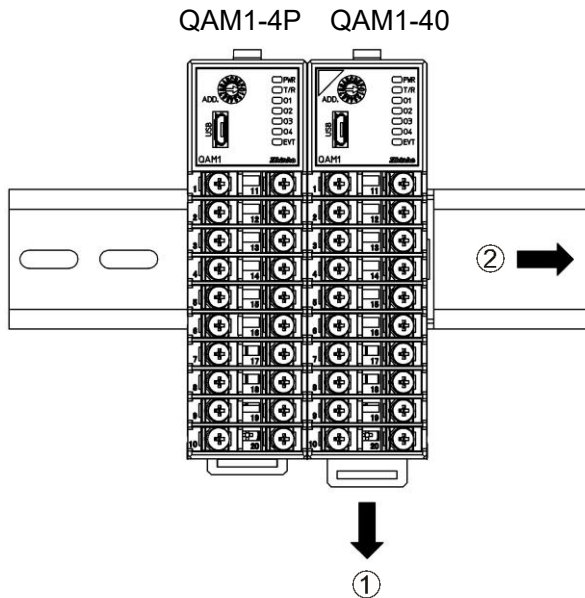

(Fig. 6.3-10)

7 Wiring



Warning

Turn off the power supply to this instrument before wiring.

If you work while the power is supplied, you may get an electric shock, which could result in an accident resulting in death or serious injury.

7.1 Recommended Terminal and Recommended Rod Terminal

Recommended terminal

Use a solderless terminal with an insulation sleeve in which an M3 screw fits as shown below.

Ring-type for power supply, serial communication section, and CUnet communication section.

Solderless terminal	Manufacturer	Model	AWG	Tightening torque
Y-type	NICHIFU TERMINAL INDUSTRIES CO., LTD.	TMEX1.25Y-3	AWG22 to 16	Input/output section: 0.63 N•m Power supply section: 0.5 N•m Serial communication section: 0.3 N•m CUnet communication section: 0.3 N • m
	J.S.TMFG.CO.,LTD.	VD1.25-B3A		
Ring-type	NICHIFU TERMINAL INDUSTRIES CO., LTD.	TMEX1.25-3	AWG22 to 16	
		TMEX2-3S	AWG16 to 14	
	J.S.TMFG.CO.,LTD.	V1.25-3	AWG22 to 16	
		V2-MS3	AWG16 to 14	

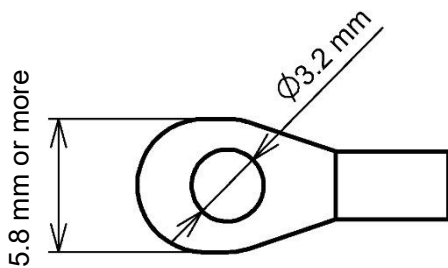

(Fig. 7.1-1)

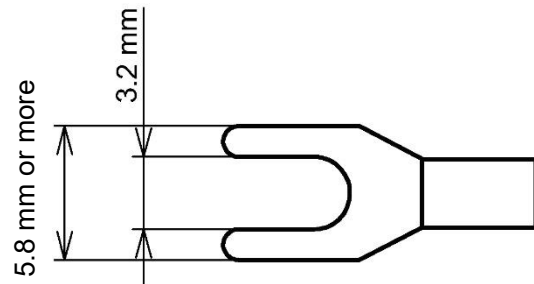

(Fig. 7.1-2)

Recommended rod terminal (connector specifications)

For connector specifications, use PHOENIX CONTACT brand rod terminals with insulating sleeves and crimping tools for the input/output sections.

Model	AWG	Crimping tool
AI 0,25-10 YE	AWG24	ZA3 CRIMPFOX UD 6
AI 0,34-10 TQ	AWG22	
AI 0.5-10 WH	AWG20	
AI 0,75-10 GY or AI 1-10 RD	AWG18	
AI 1,5-10 BK	AWG16	
AI 2,5-10 BU	AWG14	
AI 4-10 GY	AWG12	

7.2 Using Terminal Cover Precaution

Attach the terminal cover TC-QTC (sold separately) (*) so that the shorter one is on the right side of the case.

For the wiring of terminal numbers 11 to 20, pass through the left side of the terminal cover.

(*): QAM1 has the same case shape as QTC1, so the terminal cover of QTC1 is used.

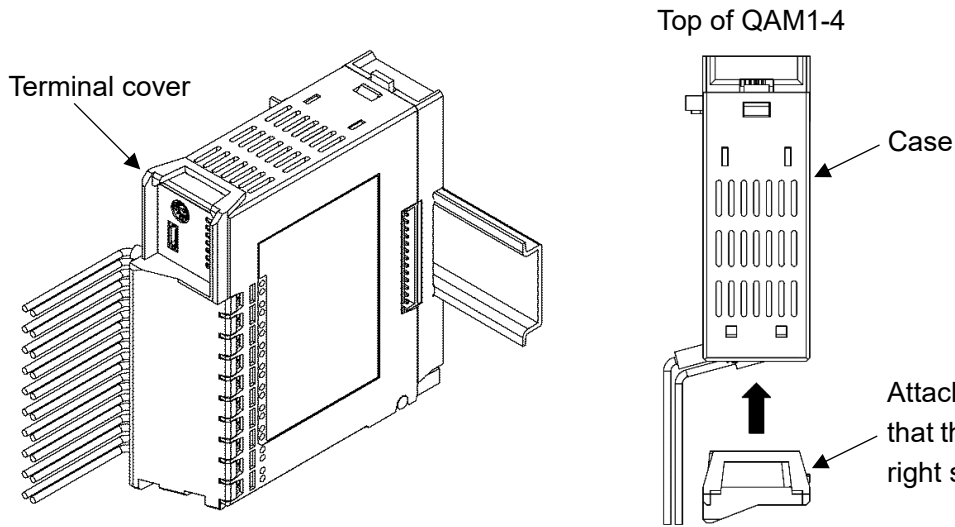

(Fig. 7.2-1)

(Fig. 7.2-2)

7.3 Terminal Arrangement

7.3.1 Input and Output Terminal Arrangement



Caution

- Please note that CH1, CH2 and CH3, CH4 have different terminal arrangements.

Terminal block type

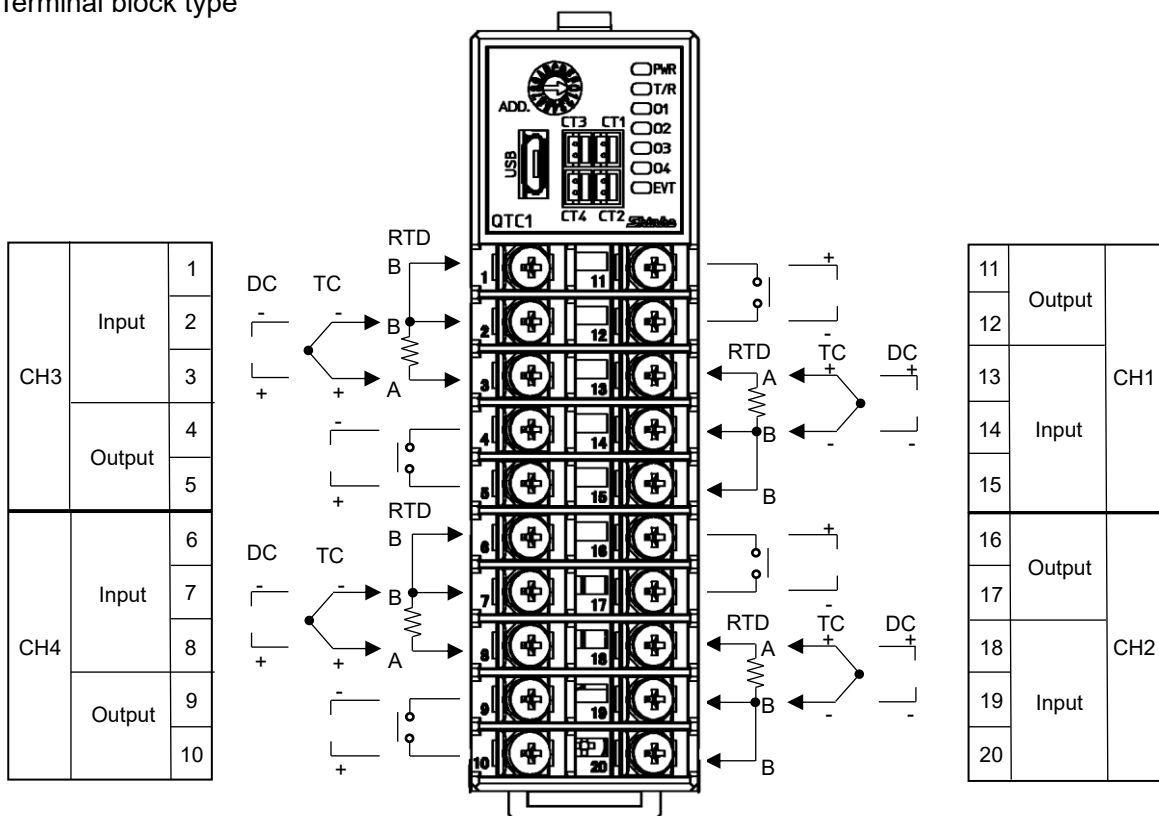

(Fig. 7.3.1-1)

Connector type

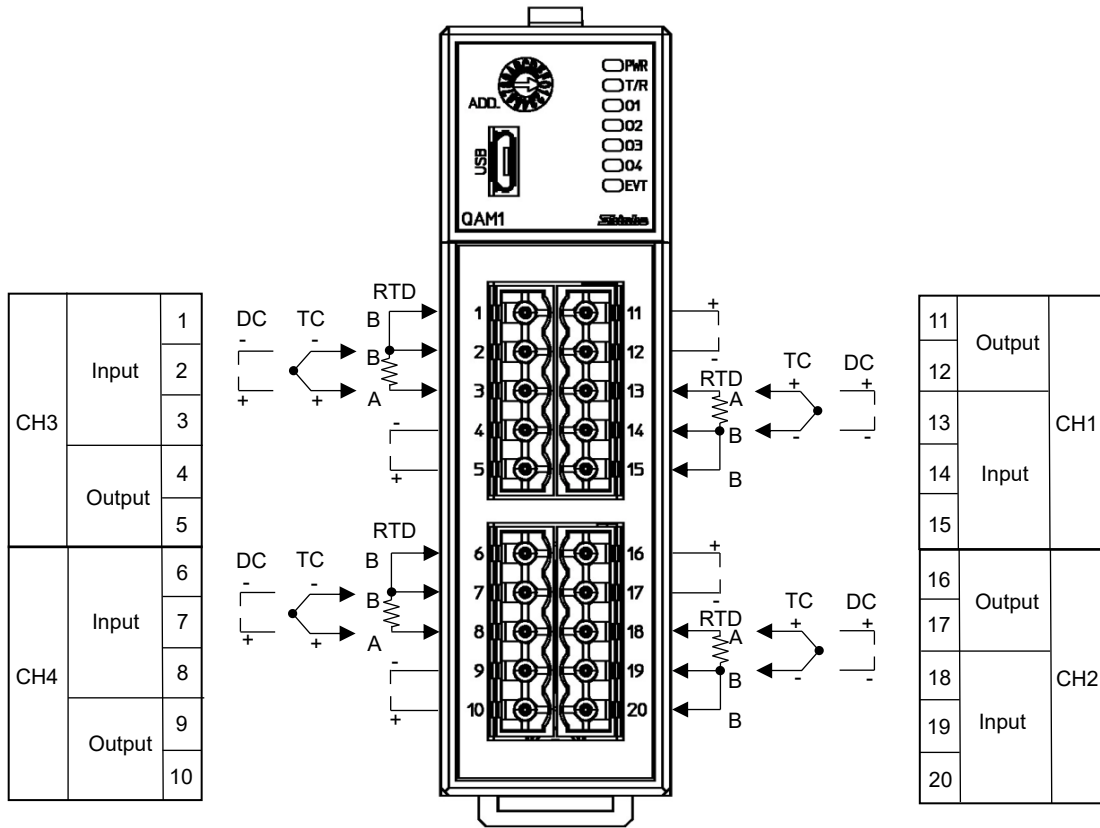

(Fig. 7.3.1-2)

7.3.2 Power Supply and Serial Communication Terminal Arrangement

Serial communication RS-485

CUnet communication

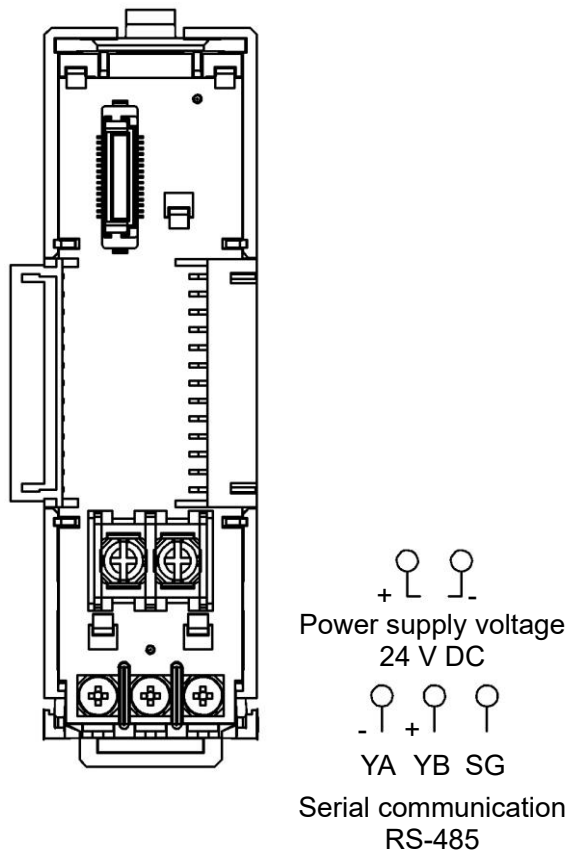

(Fig. 7.3.2-1)

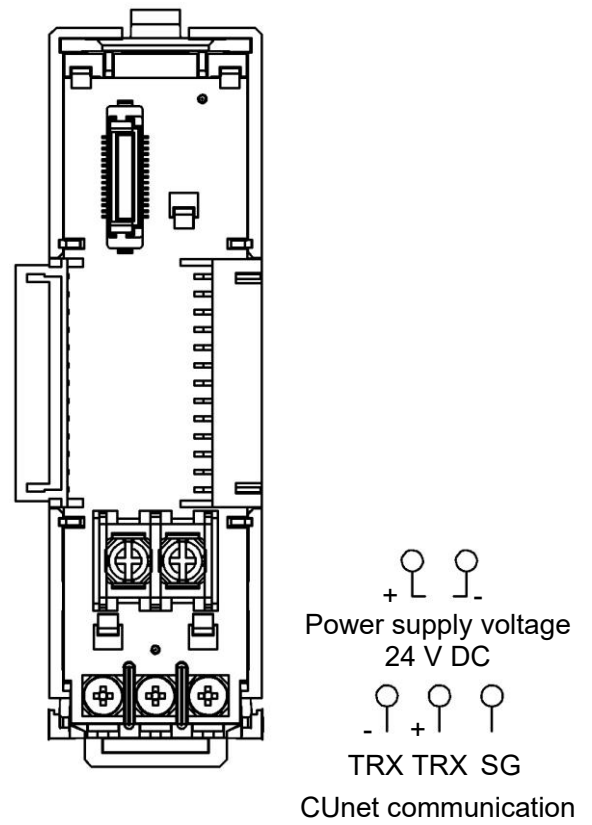

(Fig. 7.3.2-2)

7.4 Wiring

7.4.1 Wiring for Power Supply and Communication

The terminal block for power supply and communication is located on the base of this instrument. Wiring by the following procedure.

(1) Case removal

- ① Push the release lever on the top of this instrument to unlock it.
- ② Remove the case.

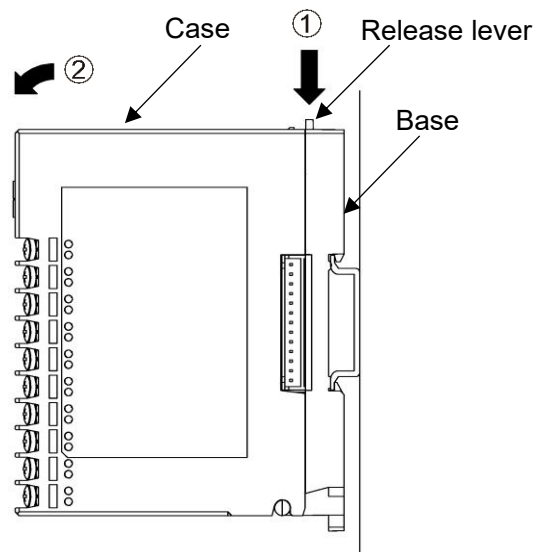

(Fig. 7.4.1-1)

(2) Wiring

Serial communication RS-485

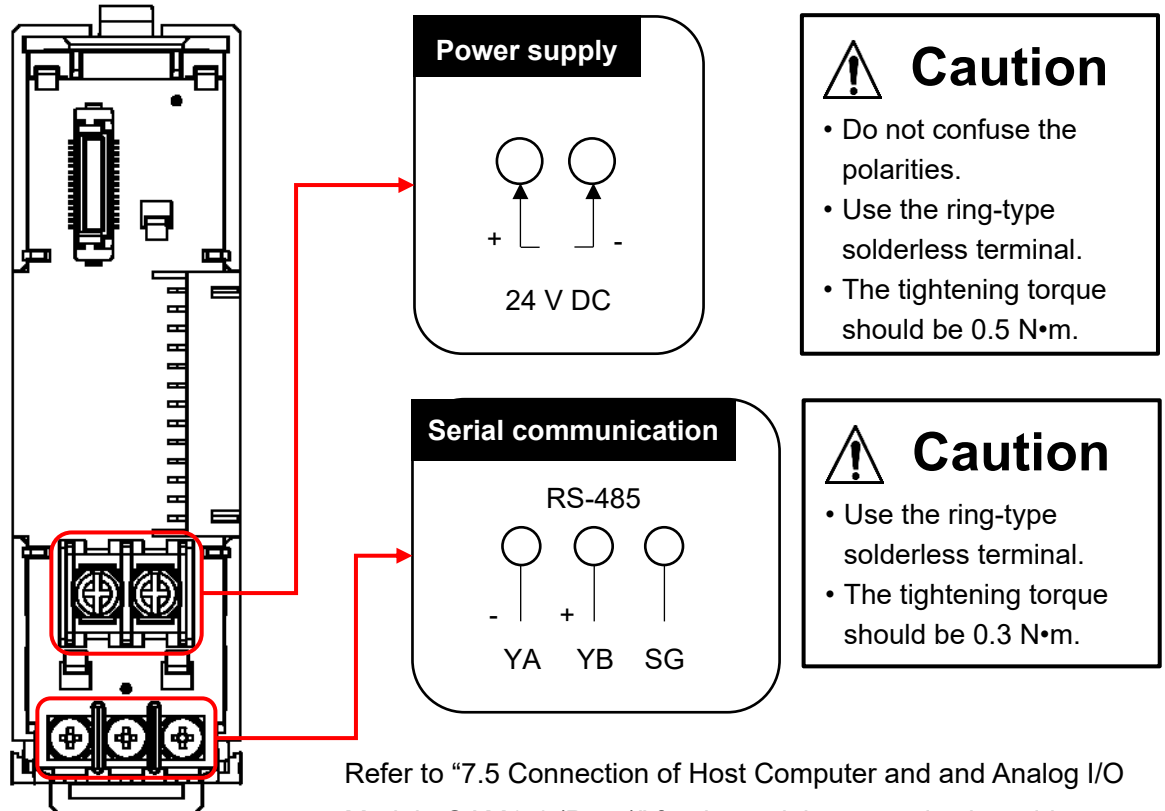

Refer to "7.5 Connection of Host Computer and and Analog I/O Module QAM1-4 (P.7-7)" for the serial communication wiring.

(Fig. 7.4.1-2)

(3) Case mounting

- ① Hook the case on the lower part ① of this instrument.
- ② Mount the case so that the lower part ① of this instrument is the fulcrum and covers the release lever. There is a clicking sound.

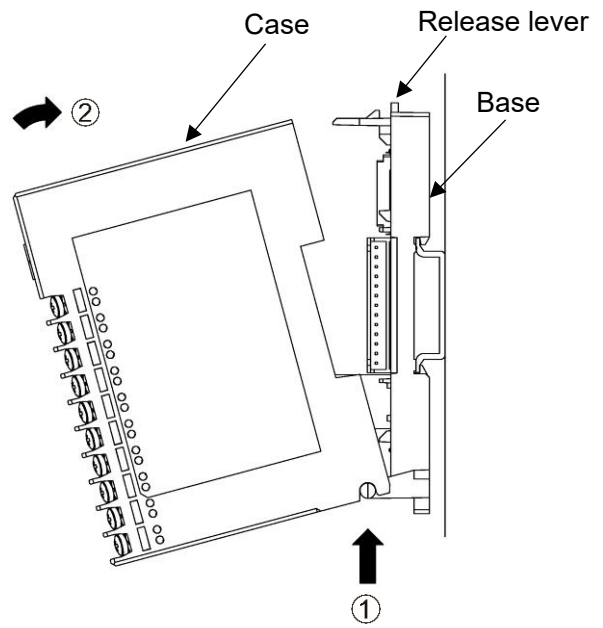

(Fig. 7.4.1-3)

7.4.2 Wiring for Input and Output



Caution

- Please note that CH1, CH2 and CH3, CH4 have different terminal arrangements.
- The tightening torque should be 0.63 N•m.
- For DC current input (with an external receiving resistor), connect a receiving resistor [option 50 Ω (RES-S01-050)] between each input terminal (+ and -). For DC current input (built-in receiving resistor), a receiving resistor (50 Ω) is not required.

Terminal block type

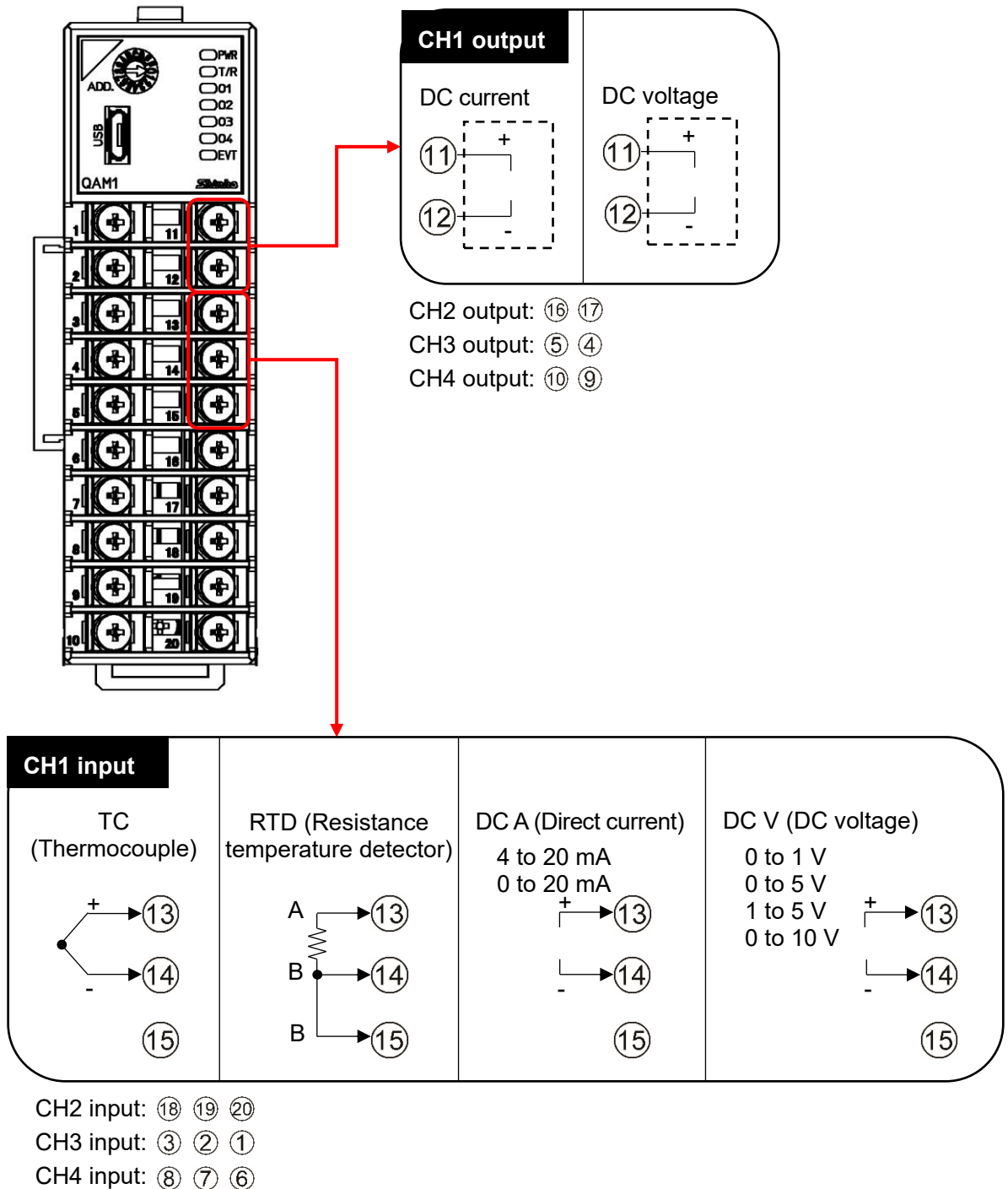

(Fig. 7.4.2-1)

Connector type

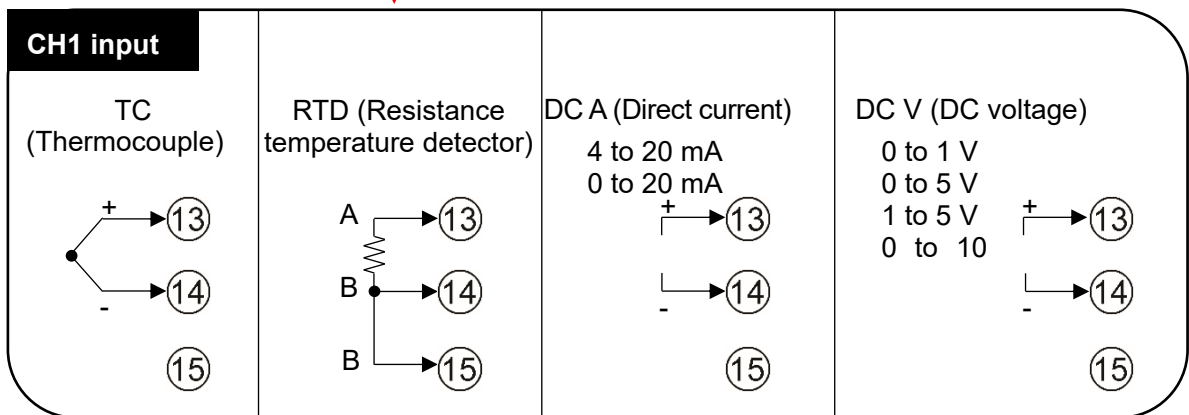
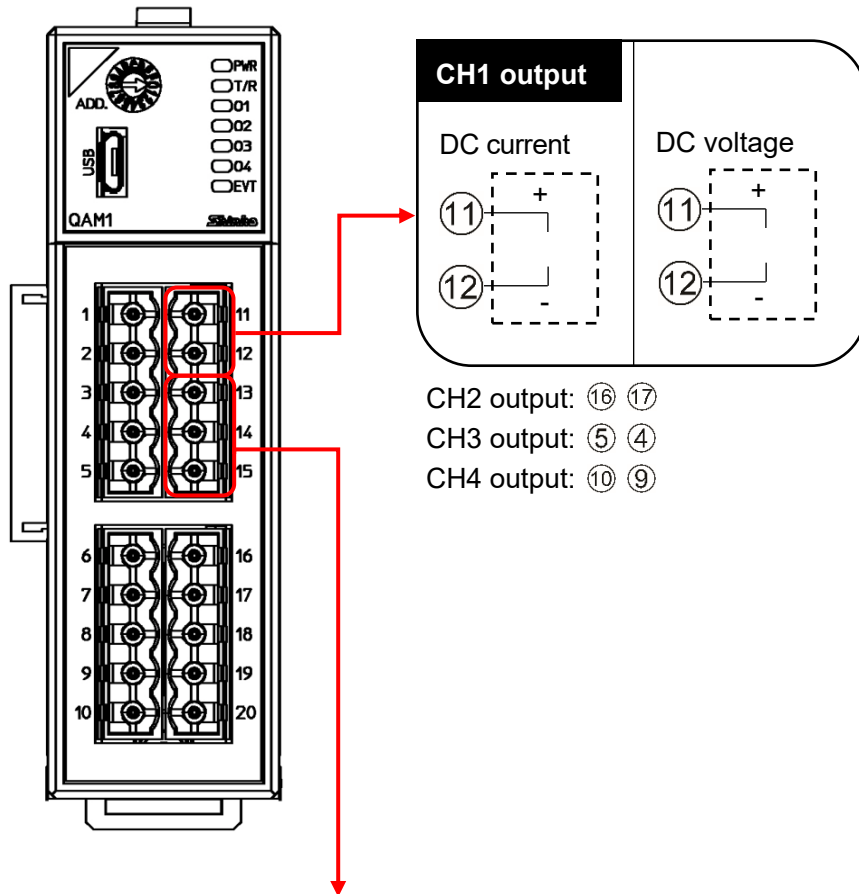

- CH2 input: 18 19 20
- CH3 input: 3 2 1
- CH4 input: 8 7 6

(Fig. 7.4.2-2)

7.5 Connection of Host Computer and Analog I/O Module QAM1-4

7.5.1 Wiring Example for Using USB Communication Cable CMC-001-1 (Sold separately)

When connecting using USB communication cable CMC-001-1 (sold separately), one analog I/O module QAM1-4P (with power supply / host communication function) is required for host communication.

The power supply and communication lines to the second and subsequent analog I/O modules are connected to the BUS using connectors.

For the second and later modules, use the analog I/O module QAM1-40 (no power supply / communication option).

A maximum of 16 modules can be connected.

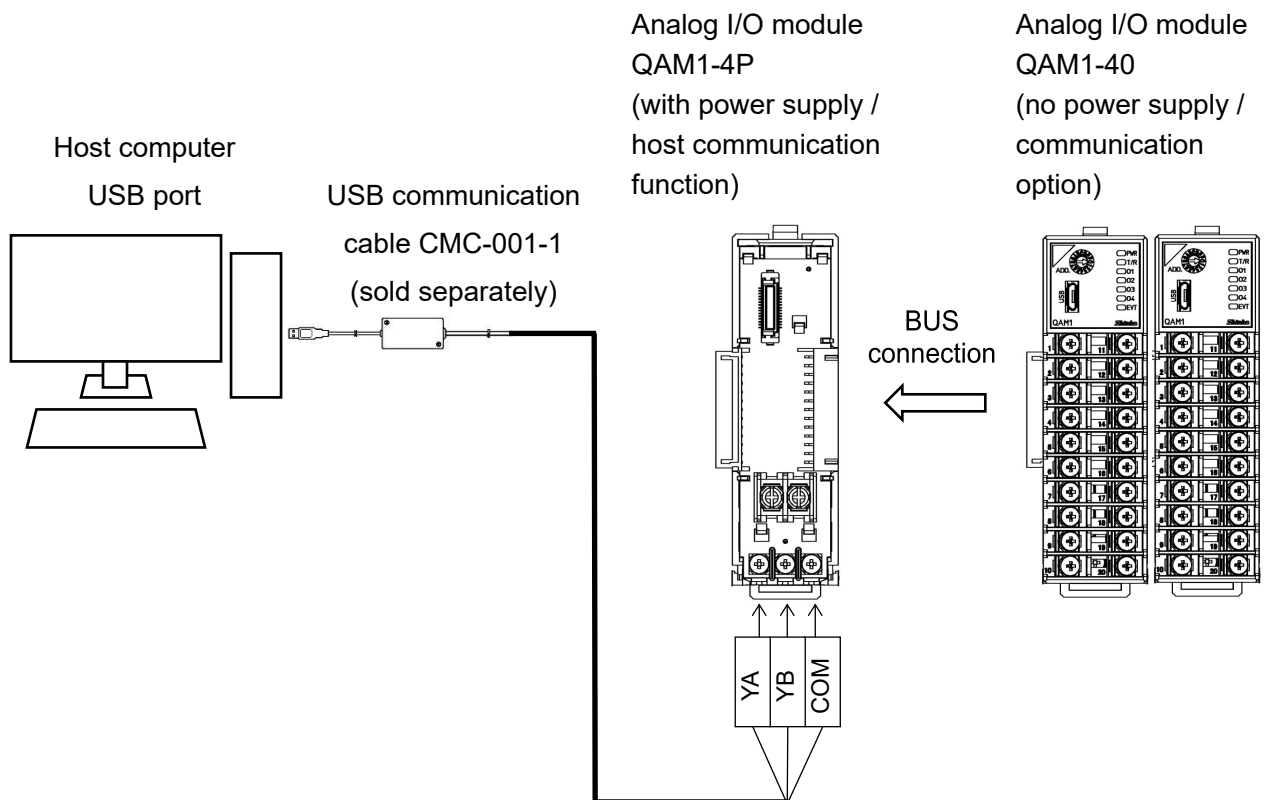

(Fig. 7.5.1-1)

7.5.2 Wiring Example for Using Communication Converter IF-400 (Sold separately)

When connecting using the communication converter IF-400 (sold separately), one analog I/O module QAM1-4P (with power supply / host communication function) is required for host communication.

The power supply and communication lines to the second and subsequent analog I/O modules are connected to the BUS using connectors.

For the second and later modules, use the analog I/O module QAM1-40 (no power supply / communication option).

A maximum of 16 modules can be connected.

The communication converter IF-400 (sold separately) does not support communication speeds of 38400 bps and 57600 bps.

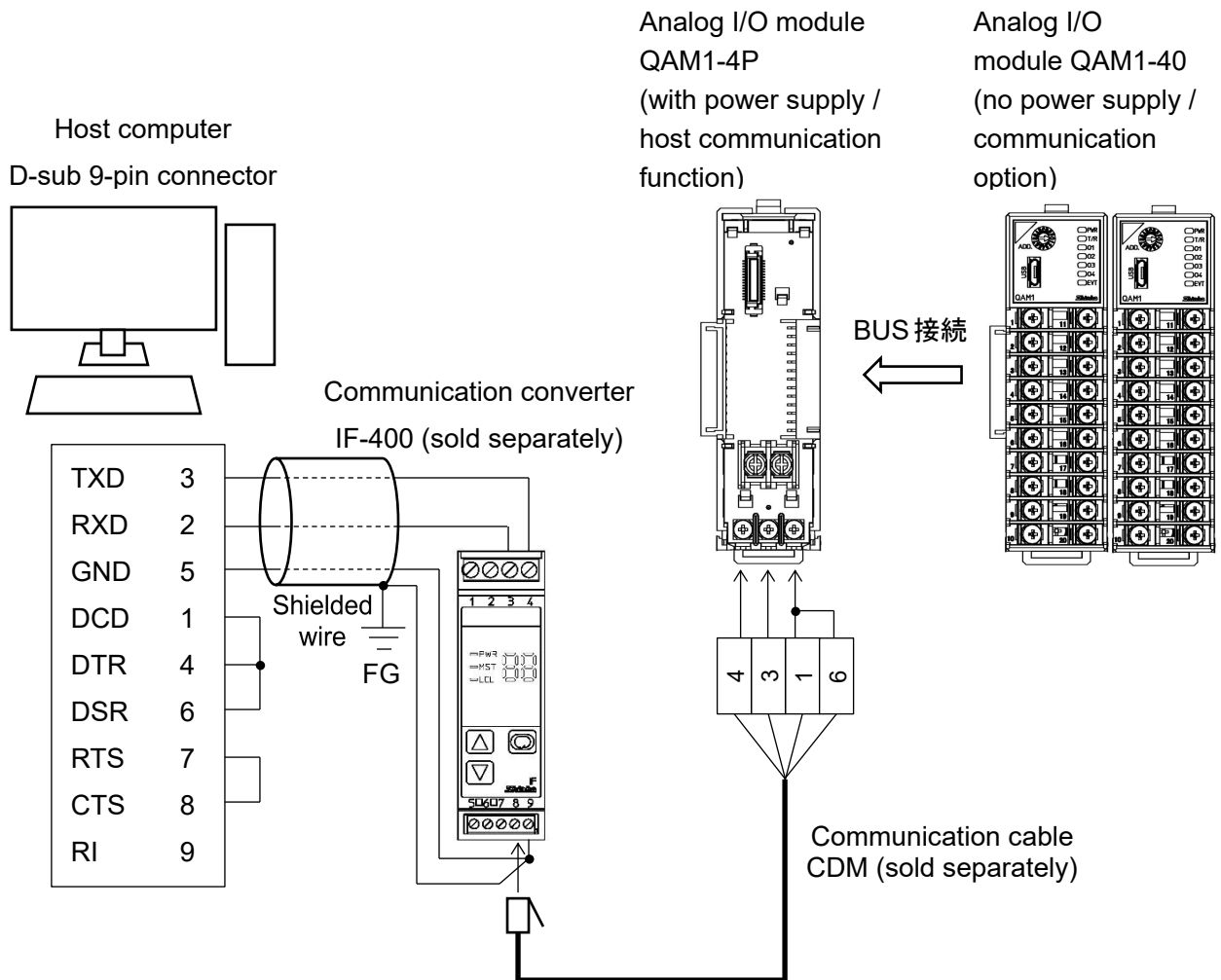

(Fig. 7.5.2-1)

Shielded wire

Connect only one side of the shielded wire to FG so that no current flows in the shield part. If both sides of the shield are connected to FG, a closed circuit will be created between the shielded wire and the ground, and a current will flow through the shielded wire, making it more susceptible to noise. Be sure to ground FG.

Recommended cable: OTSC-VB 2PX0.5SQ by Onamba Co., Ltd. or equivalent (use twisted pair shielded wire).

Termination resistor (terminator)

The communication converter IF-400 (sold separately) has a built-in termination resistor.

The termination resistor is also called a terminator. It is a resistor attached to the end of wiring when peripheral devices are connected to the host computer in a chain, and prevents signal reflection and signal disturbance at the end.

Since this instrument has a built-in pull-up resistor and pull-down resistor, no termination resistor is required on the communication line.

8 Setting of Specification

Set the specifications.

This section describes how to set specifications using console software (SWC-QTC101M).

8.1 Preparation

8.1.1 Preparation of USB Communication Cable and Console Software

Please prepare the USB communication cable and the console software.

- USB communication cable
USB-micro USB Type-B (commercial item)

- Console software (SWC-QTC101M)
Please download from our website and install.

Click <https://shinko-technos.co.jp/e/> → Support/Download → Software

8.1.2 Connecting to Host Computer

Caution

Do not use the logging function of the console software when communicating by connecting the USB communication cable.

- (1) Connect the micro USB Type-B side of the USB communication cable to the console communication connector of this instrument.
- (2) Connect the USB plug of the USB communication cable to the USB port of the host computer.

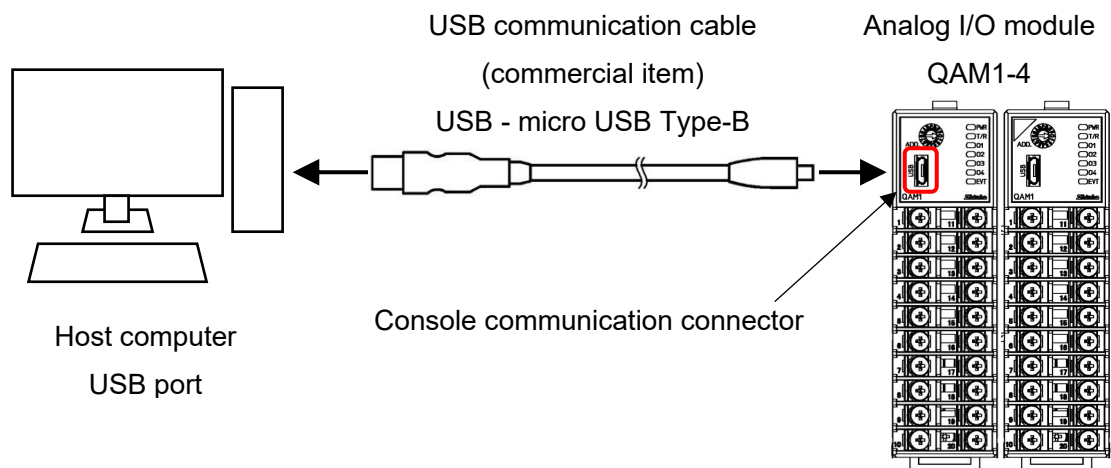

(Fig. 8.1.2-1)

(3) Checking the COM port number

Follow the procedure below to check the COM port number.

- ① Right-click "Start" → Click "Device manager" from menu.
- ② When "USB Serial Port (COM3)" is displayed in "Port (COM and LPT)", the COM port is assigned to No. 3.

Check the COM port number, and then close "Device Manager".

(4) Starting the console software (SWC-QTC101M)

- ① Start the console software (SWC-QTC101M).

Select "QAM1-4" in the Device selection.

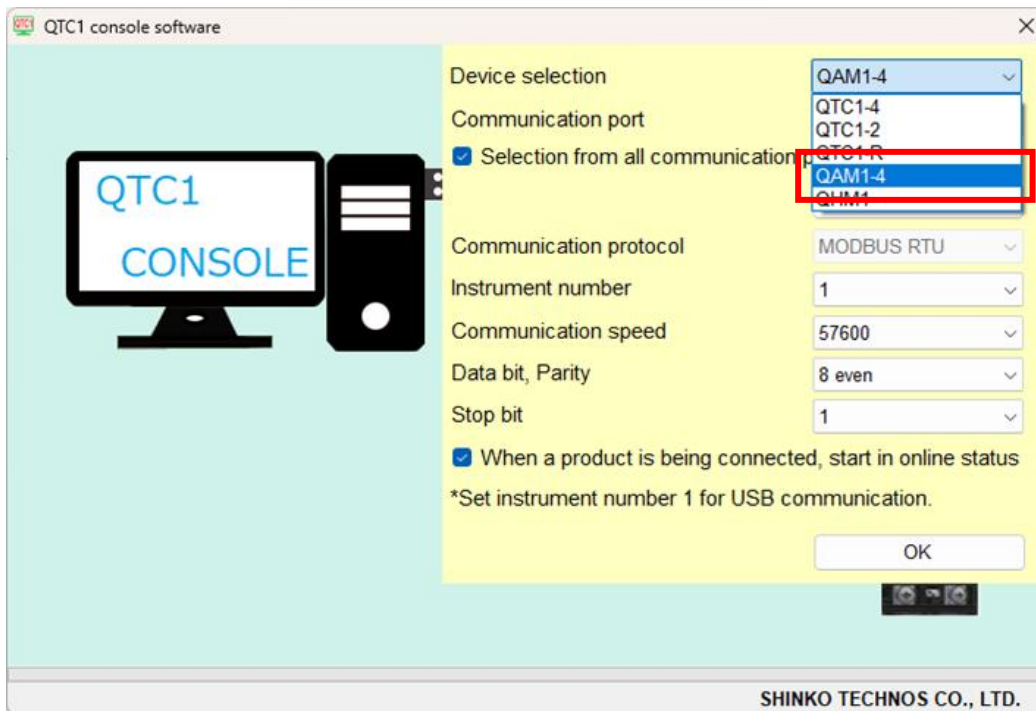

(Fig. 8.1.2-2)

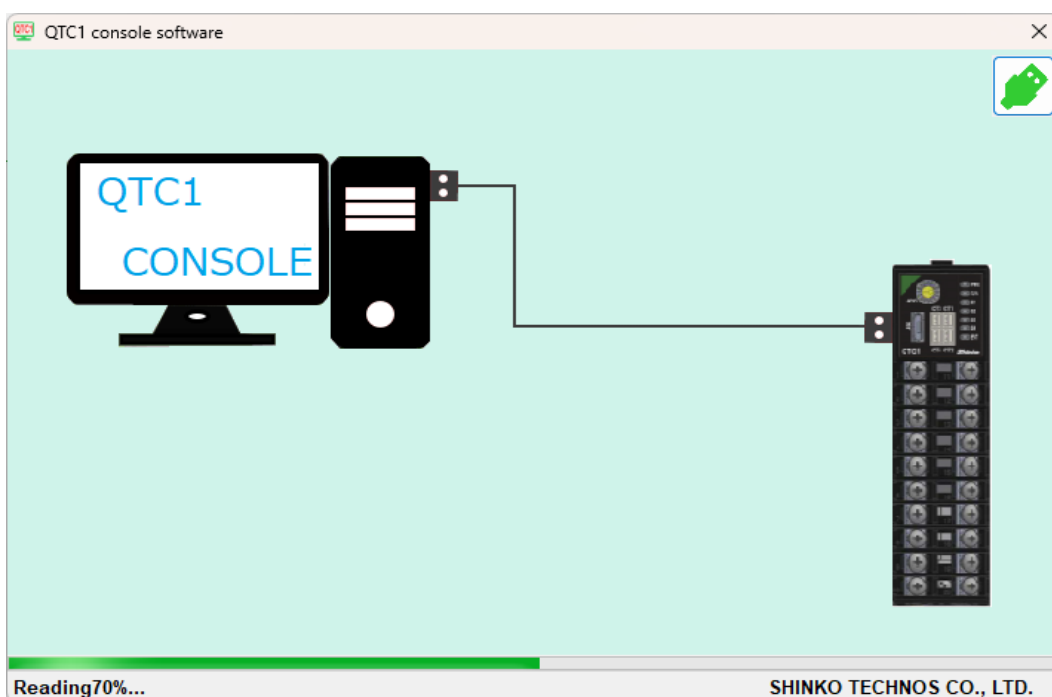

(Fig. 8.1.2-3)

② Click [User (U)] on the menu bar → [Communication conditions (C)].

Display the communication condition setting screen.

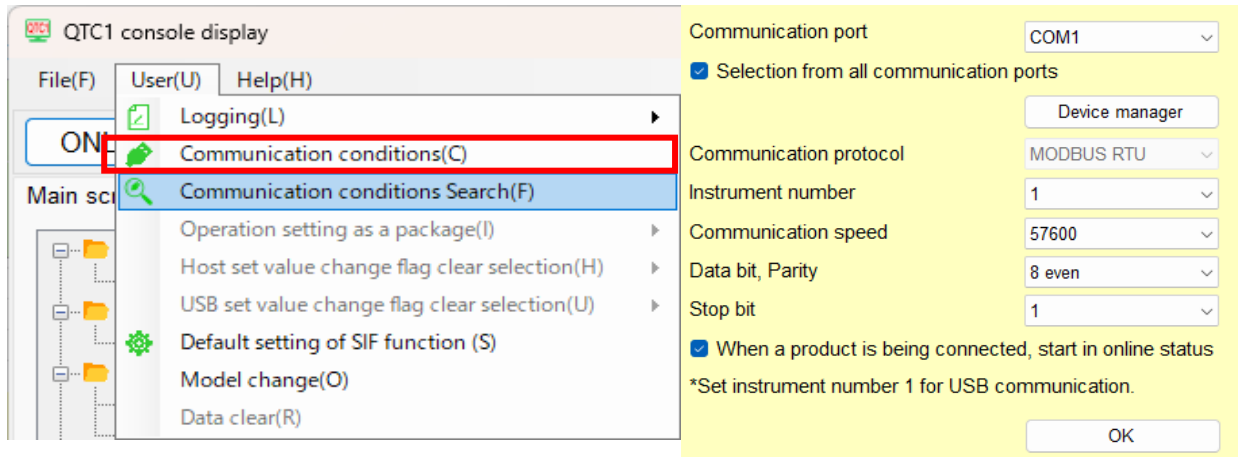

(Fig. 8.1.2-4)

*The model "QAM1-4" can also be selected from User (U) - Model change (o) in the menu bar.

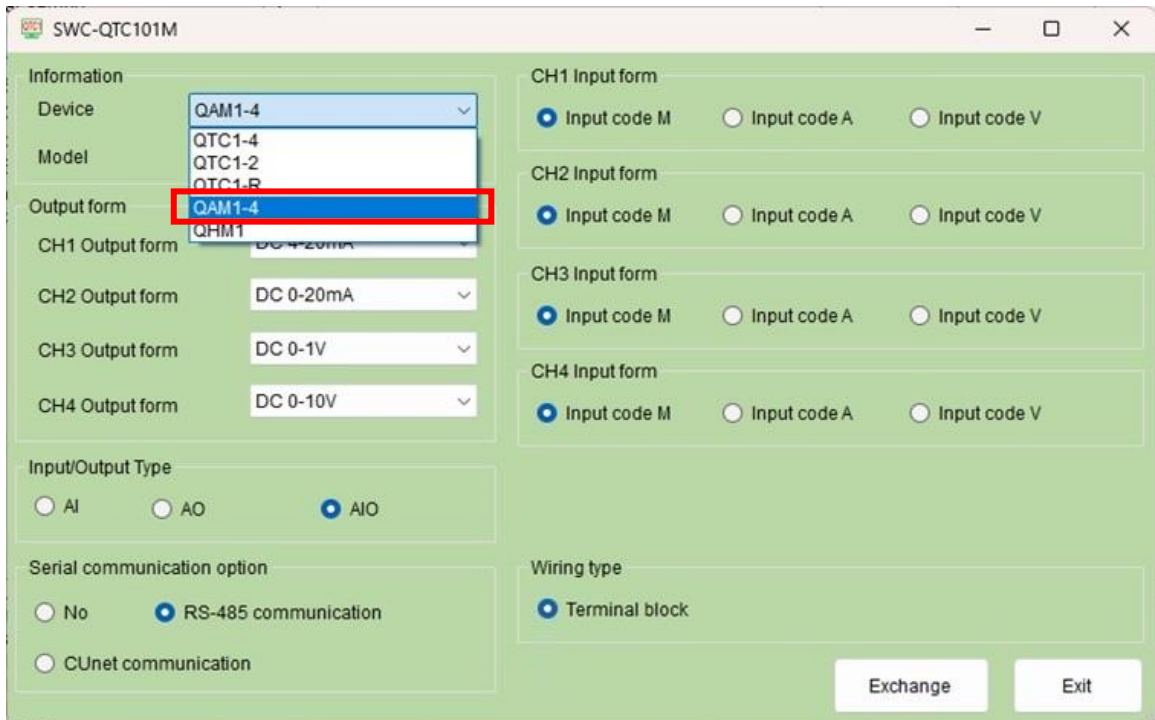

(Fig. 8.1.2-5)

- ③ Set the communication condition as shown below.

Setup Items	Setting Value
Communication port	Select the COM port number confirmed in ② of (3).
Communication protocol	MODBUS RTU

- ④ Click [OK].

- ⑤ Click [File (F)] on the menu bar → [Instrument to PC (U)].

Read all the setting values of the connected analog I/O module QAM1-4.



(Fig. 8.1.2-6)

- ⑥ Display the Monitoring value screen.

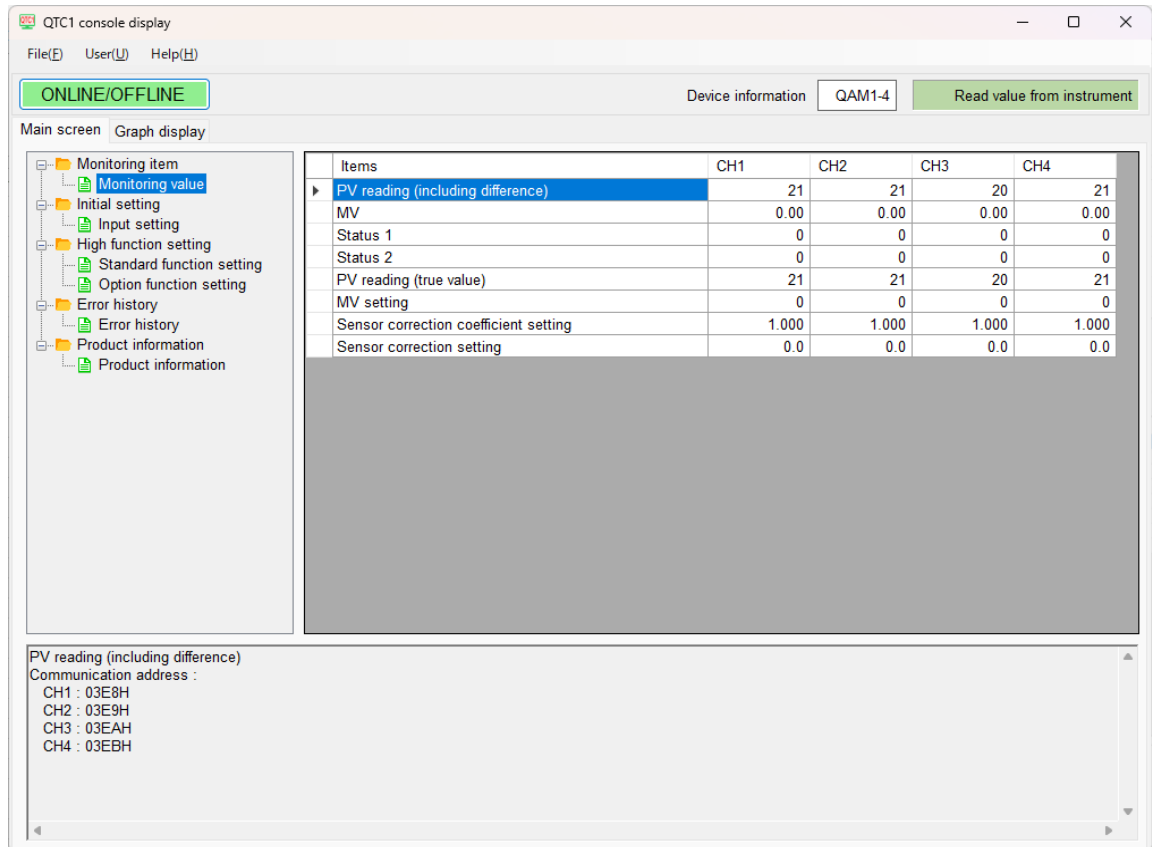

(Fig. 8.1.2-7)

The specifications are ready.

Please refer to "8.2 Specification Setting (P.8-6)" to set the specifications.

Setting the specifications for the second and subsequent modules

To set the specifications of the second and subsequent analog I/O module QAM1-4, follow the procedure below.

- ① Connect the USB communication cable to the console communication connector of the second and subsequent analog I/O module QAM1-4.
- ② Click [File (F)] on the menu bar → [Instrument to PC (U)].
Read all the setting values of the connected analog I/O module QAM1-4.



(Fig. 8.1.2-8)

- ③ Display the Monitoring value screen.

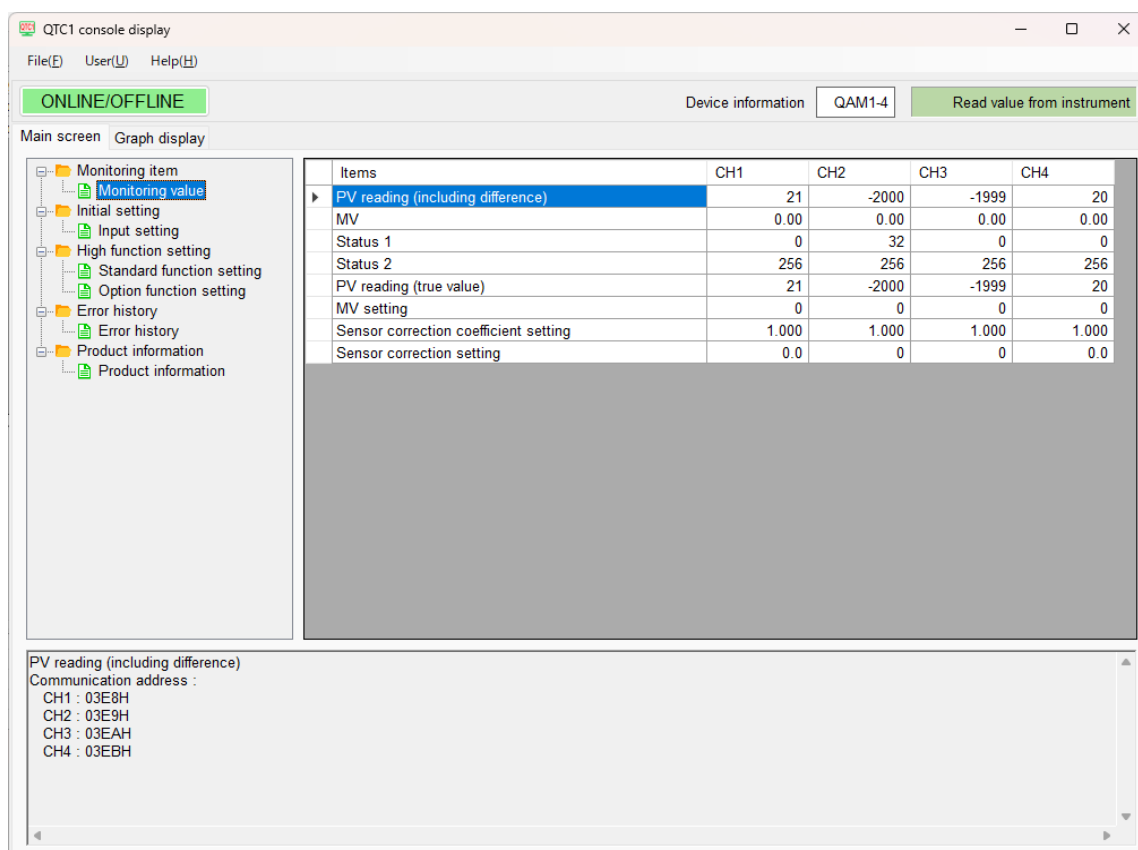

(Fig. 8.1.2-9)

Please refer to "8.2 Specification Setting (P.8-6)" to set the specifications.

8.2 Specification Setting

Basic operation of specification setting

Before setting the specifications, how to select the selection item and how to set the setting item are explained.

Select the selection item

This section explains how to select the selection item by using CH1 Input type selection as an example.

Click on the selection item for the channel.

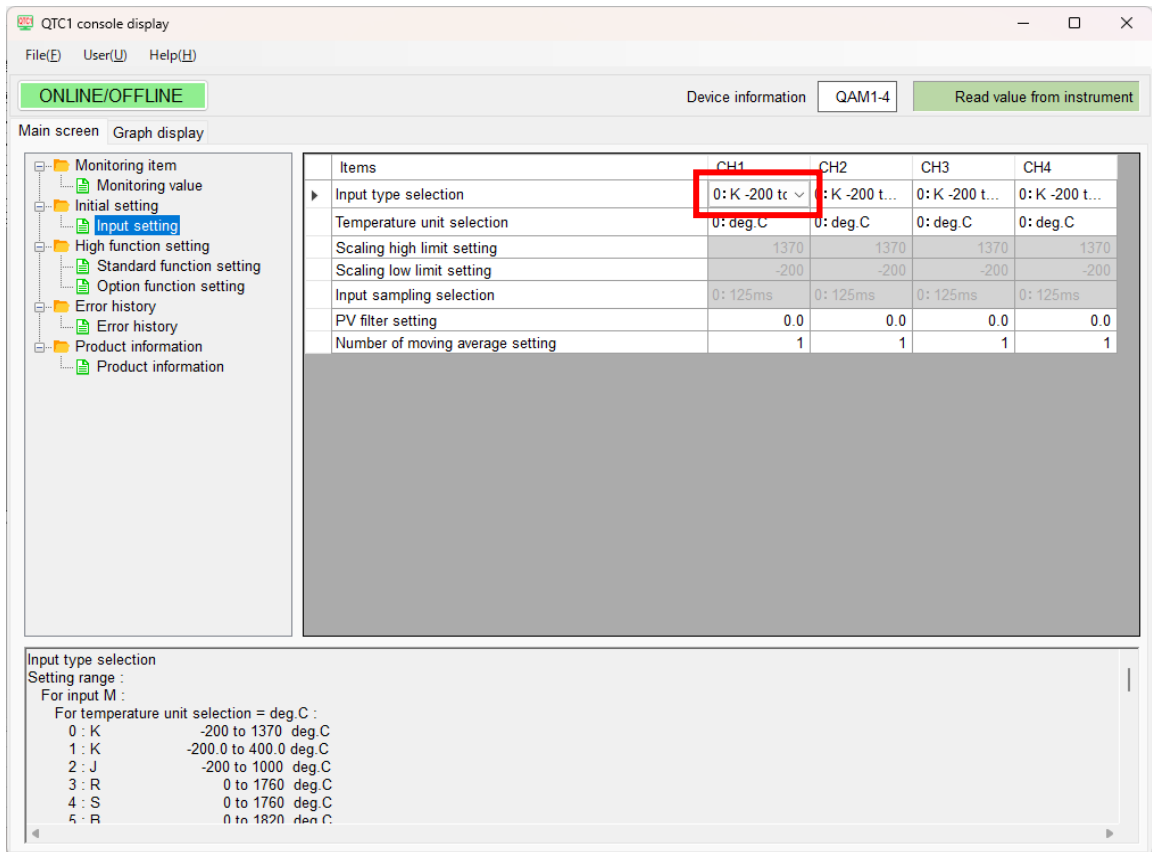

(Fig. 8.2-1)

Display the selection item list.

Select from "0: K -200 to 1370 deg C" to "14: DC 0 to 20 mA -32768 to 32767" and click.

Transfers the selected contents to the analog I/O module QAM1-4.

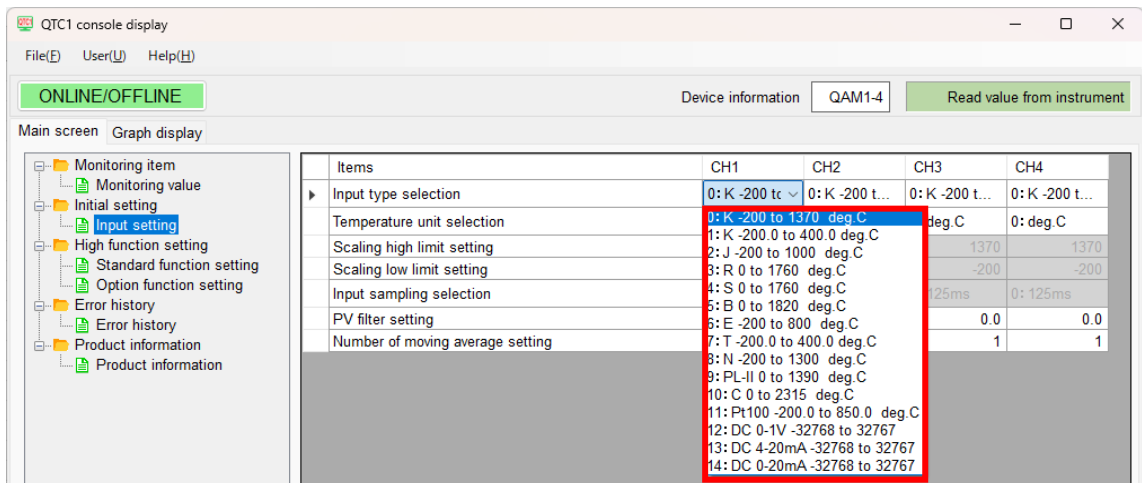

(Fig. 8.2-2)

Set the setting item

This section explains how to set the setting item by using CH1 Input scaling high limit setting as an example.

Click on the setting item for the channel.

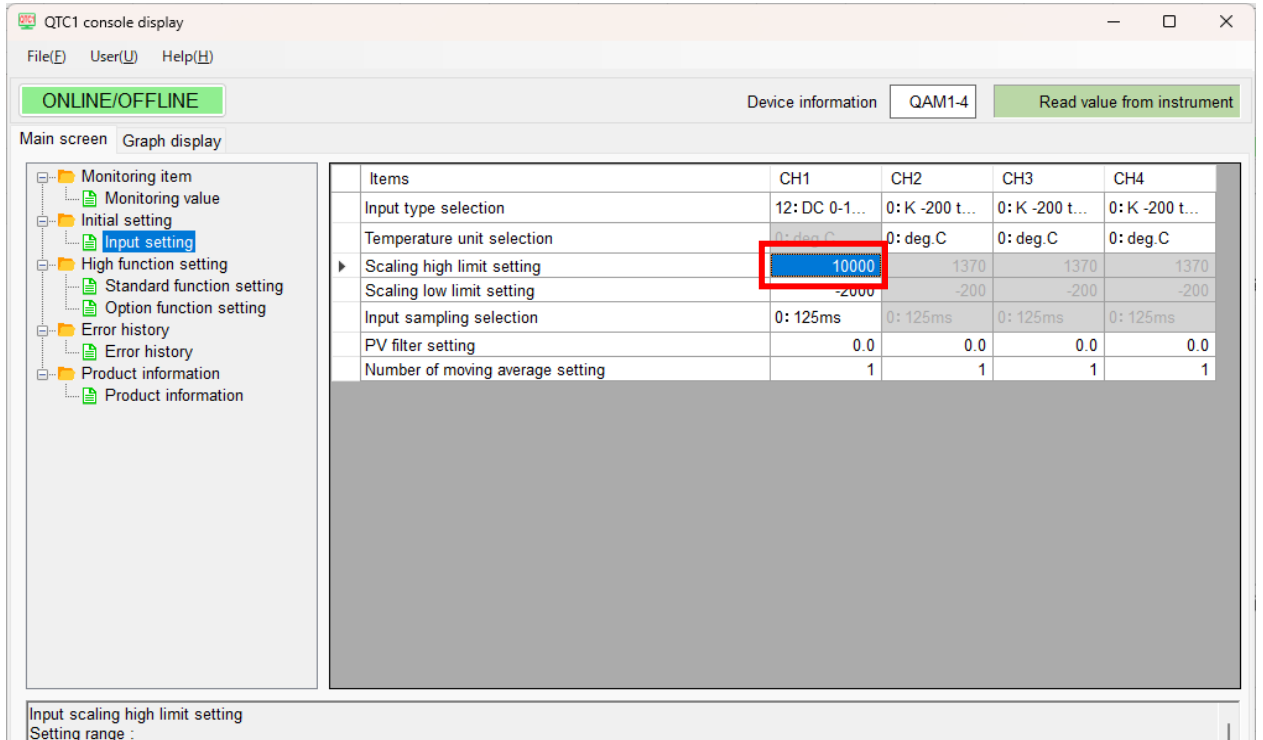

(Fig. 8.2-3)

Display the numeric keypad screen.

The current setting value and setting range are displayed on the numeric keypad screen.

Set within the setting range.

Input the setting value, and click [OK]. (*)

Transfer the setting value to the analog I/O module QAM1-4.

(*): The setting value can also be entered from the keyboard of the host computer.

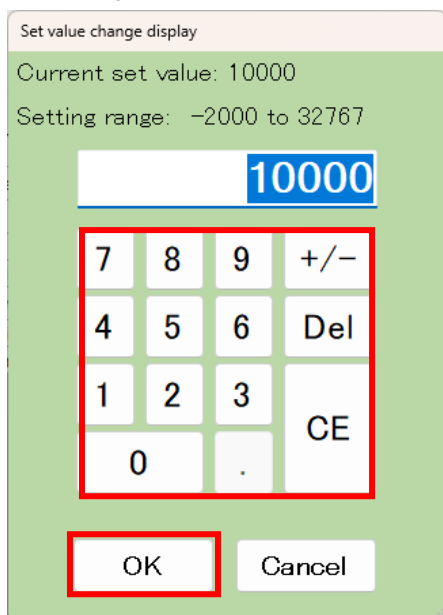

(Fig. 8.2-4)

8.2.1 Monitoring Value Setting

Display PV, output manipulated variable, state 1 reading value and state 2 reading value, and set monitor value parameters such as manual manipulated variable, sensor correction factor and sensor correction.

Click [Monitoring item] of [Main screen] tab → [Monitoring value].

Display the monitoring value screen.

The screenshot shows the QTC1 console display interface. At the top, there is a status bar with 'ONLINE/OFFLINE' (green), 'Device information' (QAM1-4), and 'Read value from instrument' (green). Below this, there are two tabs: 'Main screen' and 'Graph display'. The 'Main screen' tab is active, showing a tree view on the left with 'Monitoring item' selected. The 'Monitoring value' sub-item is highlighted. The main area displays a table with the following data:

Items	CH1	CH2	CH3	CH4
PV reading (including difference)	25	67	24	22
MV	0.00	0.00	0.00	0.00
Status 1	0	0	0	0
Status 2	256	256	256	256
PV reading (true value)	25	67	24	22
MV setting	0	0	0	0
Sensor correction coefficient setting	1.000	3.000	1.000	1.000
Sensor correction setting	0.0	0.0	0.0	0.0

At the bottom of the screen, there is a text area showing the following information:

```
PV reading (including difference)
Communication address :
CH1 : 03E8H
CH2 : 03E9H
CH3 : 03EAH
CH4 : 03EBH
```

(Fig. 8.2.1-1)

This section describes each setting item.

- Setting item
This is the setting item of analog I/O module QAM1-4.
- Channel
This is the channel number of analog I/O module QAM1-4.
- Address [HEX (Hexadecimal)]
This is the address of each channel of analog I/O module QAM1-4.
- Description, setting range and selection item
This is the description of setting item, the setting range and the selection item.
- Factory default
This is the factory shipment default value of the setting item.

Setting item	Channel	Address [HEX]	Description, setting range and selection item	Factory default
Output volume setting	CH1	0014	Sets the output volume.	0
	CH2	0015	Setting range: Output scaling lower limit to output scaling upper limit	
	CH3	0016		
	CH4	0017		
Sensor correction factor setting	CH1	0084	Set the sensor correction factor.	1.000
	CH2	0085	Set the slope of the sensor input value.	
	CH3	0086	Refer to "12.2 Correct PV (P.12-3)".	
	CH4	0087	Setting range: 0.000 to 10.000	
Sensor correction setting	CH1	0088	Set the sensor correction value.	When input code M is specified: 0°C (°F) When input code A, V is specified: 0
	CH2	0089	Refer to "12.2 Correct PV (P.12-3)".	
	CH3	008A	Setting range: -100.0 to 100.0°C	
	CH4	008B	(-180.0 to 180.0°F) -1000 to 1000 (when direct current and DC voltage input)	

8.2.2 Input Setting

Set the input parameters such as input type, temperature unit and input sampling cycle.

Click [Initial setting] of [Main screen] tab → [Input setting].

Display the Input setting screen.

The screenshot shows the QTC1 console display interface. At the top, there is a status bar with 'ONLINE/OFFLINE' and 'Device information QAM1-4 Read value from instrument'. Below this, there are two tabs: 'Main screen' and 'Graph display'. The 'Main screen' tab is active, showing a tree view on the left with 'Input setting' selected. The main area displays a table of settings for four channels (CH1, CH2, CH3, CH4).

Items	CH1	CH2	CH3	CH4
Input type selection	0: K -200 t...	0: K -200 t...	0: K -200 t...	0: K -200 t...
Temperature unit selection	0: deg.C	0: deg.C	0: deg.C	0: deg.C
Scaling high limit setting	1370	1370	1370	1370
Scaling low limit setting	-200	-200	-200	-200
Input sampling selection	0: 125ms	0: 125ms	0: 125ms	0: 125ms
PV filter setting	0.0	0.0	0.0	0.0
Number of moving average setting	1	1	1	1

Below the table, the 'Input type selection' setting is expanded, showing the following information:

Input type selection
Setting range :
For input M :
For temperature unit selection = deg.C :
0 : K -200 to 1370 deg.C
1 : K -200.0 to 400.0 deg.C
2 : J -200 to 1000 deg.C
3 : R 0 to 1760 deg.C
4 : S 0 to 1760 deg.C
5 : R 0 to 1820 deg.C

(Fig. 8.2.2-1)

Setting item	Channel	Address [HEX]	Description, setting range and selection item	Factory default
Input type selection (When input code M is specified)	CH1	00C8	Select the input type.	0: K -200 to 1370°C
	CH2	00C9	Selection item:	
	CH3	00CA	0: K -200 to 1370°C	
	CH4	00CB	1: K -200.0 to 400.0°C	
			2: J -200 to 1000°C	
		3: R 0 to 1760°C		
		4: S 0 to 1760°C		
		5: B 0 to 1820°C		
		6: E -200 to 800°C		
		7: T -200.0 to 400.0°C		
		8: N -200 to 1300°C		
		9: PL-Ⅱ 0 to 1390°C		
		10: C(W/Re5-26) 0 to 2315°C		
		11: Pt100 -200.0 to 850.0°C		
		12: 0 to 1 V DC -32768 to 32767		
		13: 4 to 20 mA DC (Externally mounted shunt resistor) -32768 to 32767		
		14: 0 to 20 mA DC (Externally mounted shunt resistor) -32768 to 32767		
Input type selection (When input code A is specified)	CH1	00C8	Select the input type.	0: 4 to 20 mA DC (Built in shunt resistor) -32768 to 32767
	CH2	00C9	Selection item:	
	CH3	00CA	0: 4 to 20 mA DC (Built in shunt resistor) -32768 to 32767	
	CH4	00CB	1: 0 to 20 mA DC (Built in shunt resistor) -32768 to 32767	
Input type selection (When input code V is specified)	CH1	00C8	Select the input type.	0: 0 to 5 V DC -32768 to 32767
	CH2	00C9	Selection item:	
	CH3	00CA	0: 0 to 5 V DC -32768 to 32767	
	CH4	00CB	1: 1 to 5 V DC -32768 to 32767	
			2: 0 to 10 V DC -32768 to 32767	
Temperature unit selection	CH1	00CC	Select the temperature unit.	0: deg. C
	CH2	00CD	Valid when input code M is specified.	
	CH3	00CE	Selection item:	
	CH4	00CF	0: deg. C 1: deg. F	

Setting item	Channel	Address [HEX]	Description, setting range and selection item	Factory default
Scaling high limit setting (*)	CH1	00D0	Set the scaling high limit.	10000
	CH2	00D1	Setting range:	
	CH3	00D2	-32768 to 32767(*)	
	CH4	00D3		
Scaling low limit setting (*)	CH1	00D4	Set the scaling low limit.	-2000
	CH2	00D5	Setting range:	
	CH3	00D6	-32768 to 32767(*)	
	CH4	00D7		
Input sampling selection	CH1	00D8	Select the input sampling cycle.	125 ms
	CH2	00D9	Selection item:	
	CH3	00DA	0: 125 ms	
	CH4	00DB	1: 50 ms 2: 20 ms It is fixed at 125 ms for thermocouple input and RTD input. If select a value other than 125 ms, it will be invalid.	
PV filter time constant setting	CH1	008C	Set the PV filter time constant.	0.0 seconds
	CH2	008D	Refer to "15.2.5 PV Filter Time Constant (P.15-3)".	
	CH3	008E	Setting range:	
	CH4	008F	0.0 to 10.0 seconds	
Number of moving average setting	CH1	0108	Set the number of moving averages that average the input values.	1 time
	CH2	0109	The input values are averaged the set number of times, and the input values are exchanged every input sampling cycle.	
	CH3	010A	If set 1 time, the moving average will not be performed.	
	CH4	010B	Setting range: 1 to 10 times	

(*): Enabled for DC voltage input and direct current input.

8.2.3 Standard Function Setting

Set the high and low output scaling limits.

Click [High function setting] of [Main screen] tab → [Standard function setting].

Display the Standard function setting screen.

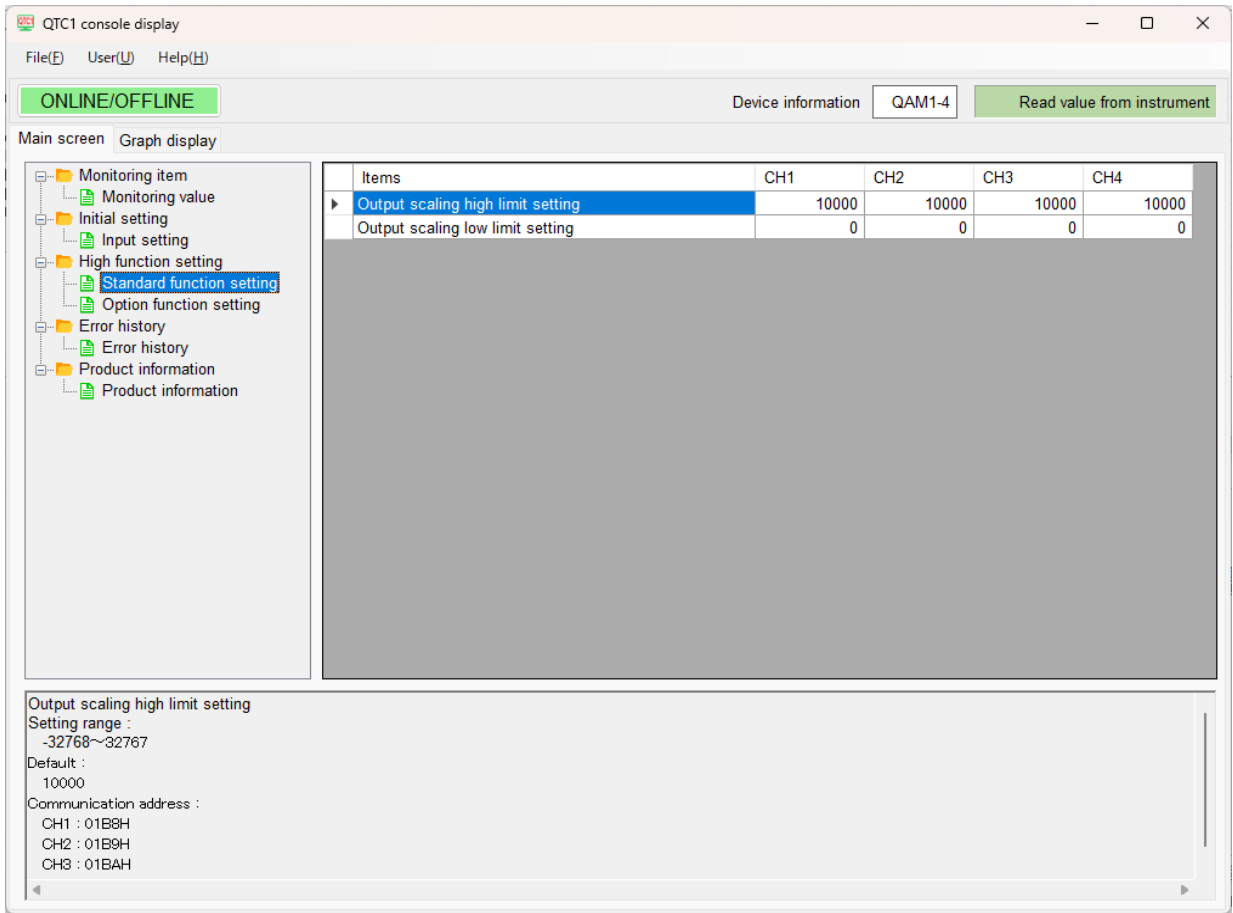

(Fig. 8.2.3-1)

Setting item	Channel	Address [HEX]	Description, setting range and selection item	Factory default
Output scaling high limit setting	CH1	01B8	Sets the output scaling high limit setting.	10000
	CH2	01B9	Setting range	
	CH3	01BA	-32768 to 32767	
	CH4	01BB		
Output scaling lower limit setting	CH1	01BC	Sets the output scaling low limit setting.	0
	CH2	01BD	Setting range	
	CH3	01BE	-32768 to 32767	
	CH4	01BF		

8.2.4 Option Function Setting

Set the communication response delay time setting.

Click [High function setting] of [Main screen] tab → [Option function setting].

Display the Option function setting screen.

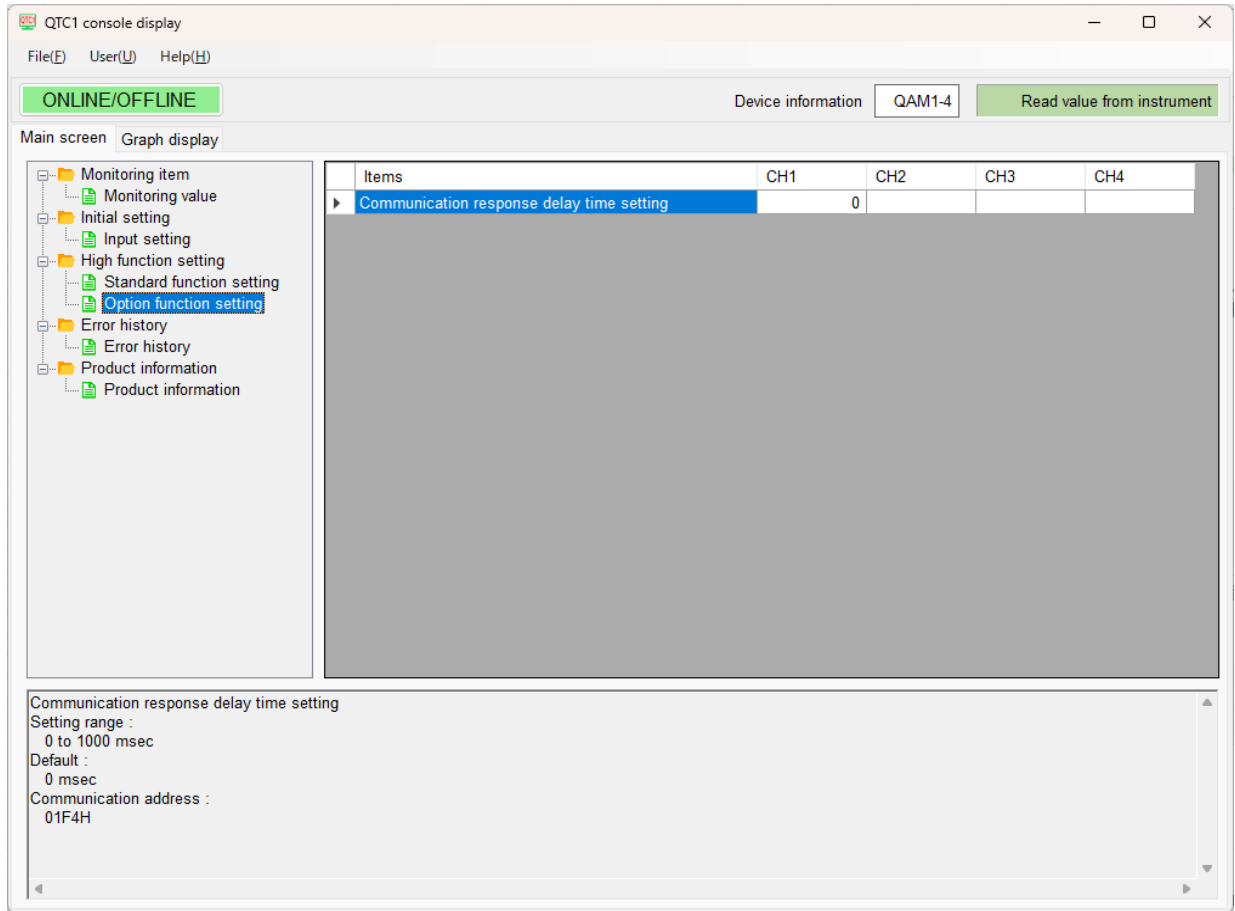

(Fig. 8.2.4-1)

Setting item	Channel	Address [HEX]	Description, setting range and selection item	Factory default
Communication response delay time setting		01F4	Set the delay time for returning a response after receiving a command from the host. When connecting to the communication expansion module QMC1, set the communication response delay time to 0 ms (initial value). Setting range: 0 to 1000 ms	0 ms

9 Communication Procedure

Communication starts with command transmission from the host computer (hereafter Master), and ends with the response of this instrument (hereafter Slave).

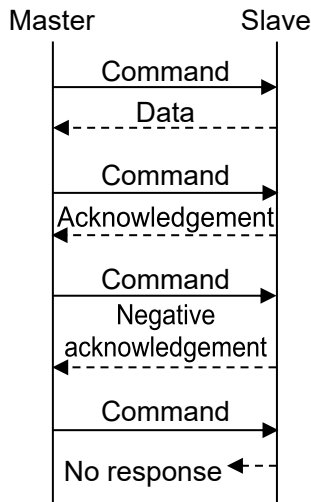

(Fig. 9-1)

- Response with data
When the master sends the Read command, the slave responds with the corresponding set value or current status.
- Acknowledgement
When the master sends the Write command, the slave responds by sending the acknowledgement after the processing is terminated.
- Negative acknowledgement
When the master sends a non-existent command or value out of the setting range, the slave returns a negative acknowledgement.
- No response
The slave will not respond to the master in the following cases:
 - Broadcast address is set.
 - Communication error (framing error, parity error)
 - CRC-16 discrepancy

Communication timing of the RS-485

Master Side (Take note while programming)

When the master starts transmission through the RS-485 communication line, the master is arranged so as to provide an idle status (mark status) transmission period of 1 or more characters before sending the command to ensure synchronization on the receiving side.

Set the program so that the master can disconnect the transmitter from the communication line within a 1 character transmission period after sending the command in preparation for reception of the response from the slave.

To avoid collision of transmissions between the master and the slave, send the next command after carefully checking that the master has received the response.

If a response to the command is not returned due to communication errors, set the Retry Processing to send the command again. (It is recommended to execute Retry twice or more.)

Slave Side

When the slave starts transmission through the RS-485 communication line, the slave is arranged so as to provide an idle status (mark status) transmission period of 1 ms or more (*) before sending the response to ensure synchronization on the receiving side.

The slave is arranged so as to disconnect the transmitter from the communication line within a 1 character transmission period after sending the response.

(*): Can be set in "Communication response delay time setting (P.8-13)" within a range of 0 to 1000 ms.

10 MODBUS Protocol

10.1 Transmission Mode

It becomes the RTU mode, and 8-bit binary data in command is transmitted as it is.

Data format	Start bit:	1 bit
	Data bit:	8 bits
	Parity:	Even (Odd, No parity) (Selectable)
	Stop bit:	1 bit (2 bits) (Selectable)
Error detection:		CRC-16 (Cyclic Redundancy Check)

10.2 Data Communication Interval

1.5 character transmission times or less

(Communication speed 9600 bps, 19200 bps: 1.5 character transmission times,

Communication speed 38400 bps, 57600 bps: 750 μs)

To transmit continuously, an interval between characters which consist of one message, must be within 1.5 character transmission times.

If the time is longer than the above, it is assumed that transmission from the master side has finished, and a communication error occurs and no response is returned.

10.3 Message Configuration

Message is configured to start after idle time is processed for more than 3.5 character transmissions, and end after idle time is processed for more than 3.5 character transmissions.

(Communication speed 9600 bps, 19200 bps: 3.5 character transmission times,

Communication speed 38400 bps, 57600 bps: 1.75 ms)

The data part has a maximum of 252 bytes.

3.5 idle characters	Slave address	Function code	Data	Error check CRC-16	3.5 idle characters
---------------------	---------------	---------------	------	--------------------	---------------------

(1) Slave Address

Slave address is an individual instrument number on the slave side, and is set within the range 1 to 16 (01H to 10H). The master identifies slaves by the slave address of the requested message.

The slave informs the master which slave is responding to the master by placing its own address in the response message.

Slave address 0 (00H, Broadcast address) can identify all the slaves connected. However, slaves do not respond.

(2) Function Code

The function code is the command code for the slave to undertake one of the following actions.

Type	Function Code	Sub Function Code	Contents
Data access	03(03H)		Reads a single or multiple piece(s) of data from slave(s) (Amount of data: Max. 100).
	06(06H)		Writes a single piece of data to slave(s).
	16(10H)		Writes multiple pieces of data to slave(s) (Amount of data: Max. 20).

The function code is used to discern whether the response is normal (acknowledgement) or if any error (negative acknowledgement) has occurred when the slave returns the response message to the master.

When acknowledgement is returned, the slave simply returns the original function code.

When negative acknowledgement is returned, the MSB of the original function code is set as 1 for the response.

For example, if the master sends request message setting 13H to the function code by mistake, slave returns 93H by setting the MSB to 1, because the former is an illegal function.

For negative acknowledgement, the exception codes below are set to the data of the response message, and returned to the master in order to inform it of what kind of error has occurred.

Exception Code	Contents
1(01H)	Illegal function (Non-existent function)
2(02H)	Illegal data address (Non-existent data address)
3(03H)	Illegal data value (Value out of the setting range)
17(11H)	Status unable to be written.

(3) Data

Data differs depending on the function code.

A request message from the master is composed of a data item, amount of data and setting data.

A response message from the slave is composed of the byte count, data and exception codes in negative acknowledgements, corresponding to the request message.

The effective range of data is -32768 to 32767 (8000H to 7FFFH).

Refer to "11.1 Communication Command List (P.11-1)".

(4) Error Check

After calculating CRC-16 (Cyclic Redundancy Check) from the slave address to the end of the data, the calculated 16-bit data is appended to the end of message in sequence from low order to high order.

[How to calculate CRC-16]

In the CRC-16 system, the information is divided by the polynomial series. The remainder is added to the end of the information and transmitted. The generation of a polynomial series is as follows.

(Generation of polynomial series: $X^{16} + X^{15} + X^2 + 1$)

- ① Initialize the CRC-16 data (assumed as X) (FFFFH).
- ② Calculate exclusive OR (XOR) with the 1st data and X. This is assumed as X.
- ③ Shift X one bit to the right. This is assumed as X.
- ④ When a carry is generated as a result of the shift, XOR is calculated by X of ③ and the fixed value (A001H). This is assumed as X. If a carry is not generated, go to step ⑤.
- ⑤ Repeat steps ③ and ④ until shifting 8 times.
- ⑥ XOR is calculated with the next data and X. This is assumed as X.
- ⑦ Repeat steps ③ to ⑤.
- ⑧ Repeat steps ③ to ⑤ up to the final data.
- ⑨ Set X as CRC-16 to the end of message in sequence from low order to high order.

10.4 Message Example

Numerals written below the command represent the number of characters.

(1) Read [Slave address 1, CH1 PV (03E8H)]

- A request message from the master

Idle 3.5 characters	Slave address (01H)	Function code (03H)	Data item (03E8H)	Amount of data (0001H)	Error check CRC-16 (047AH)	Idle 3.5 characters
	1	1	2	2	2	

- Response message from the slave in normal status [When PV=600°C (0258H)]

Idle 3.5 characters	Slave address (01H)	Function code (03H)	Response byte count (02H)	Data (0258H)	Error check CRC-16 (B8DEH)	Idle 3.5 characters
	1	1	1	2	2	

(2) Write [Slave address 1, CH1 Output volume (0014H)]

- A request message from the master [When Output volume 1000 (03E8H)]

Idle 3.5 characters	Slave address (01H)	Function code (06H)	Data item (0014H)	Data (03E8H)	Error check CRC-16 (C970H)	Idle 3.5 characters
	1	1	2	2	2	

- Response message from the slave in normal status

Idle 3.5 characters	Slave address (01H)	Function code (06H)	Data item (0014H)	Data (03E8H)	Error check CRC-16 (C970H)	Idle 3.5 characters
	1	1	2	2	2	

- Response message from the slave in exception (error) status (When a value out of the setting range is set)

The function code MSB is set to 1 for the response message in exception (error) status, and 86H is returned.

The exception code 03H (Value out of the setting range) is returned (error).

Idle 3.5 characters	Slave address (01H)	Function code (86H)	Exception code (03H)	Error check CRC-16 (0261H)	Idle 3.5 characters
	1	1	1	2	

(3) Read [Slave address 1, CH1 Output volume (0014H)]

- A request message from the master

Idle 3.5 characters	Slave address (01H)	Function code (03H)	Data item (0014H)	Amount of data (0001H)	Error check CRC-16 (C40EH)	Idle 3.5 characters
	1	1	2	2	2	

- Response message from the slave in normal status [When Output volume 1000 (03E8H)]

Idle 3.5 characters	Slave address (01H)	Function code (03H)	Response byte count (02H)	Data (0258H)	Error check CRC-16 (B8FAH)	Idle 3.5 characters
	1	1	1	2	2	

- Response message from the slave in exception (error) status (When data item is incorrect)

The function code MSB is set to 1 for the response message in exception (error) status, and 83H is returned.

The exception code 02H (Non-existent data address) is returned (error).

Idle 3.5 characters	Slave address (01H)	Function code (83H)	Exception code (02H)	Error check CRC-16 (C0F1H)	Idle 3.5 characters
	1	1	1	2	

(4) Write 4 commands [Slave address 1, CH1 Output volume (0014H) to CH4 Output volume (0017H)]
(Writing multiple pieces of data)

The configuration of the data is as follows.

Amount of data : 4(0004H)

Byte count : 8(08H)

Data : Data is converted to Hexadecimal.

Data Item		Data	Data (Converted to Hexadecimal)
0014H	CH1 Output volume setting	1000	03E8H
0015H	CH2 Output volume setting	1000	03E8H
0016H	CH3 Output volume setting	1000	03E8H
0017H	CH4 Output volume setting	1000	03E8H

- A request message from the master (When writing the above data)

Idle 3.5 characters	Slave address (01H)	Function code (10H)	Data item (0014H)	Data (00040803E803E803E803E8H)
	1	1	2	11

Error check CRC-16 (4EBBH)	Idle 3.5 characters
2	

- Response message from the slave in normal status

Idle 3.5 characters	Slave address (01H)	Function code (10H)	Data item (0014H)	Data (0004H)	Error check CRC-16 (81CEH)	Idle 3.5 characters
	1	1	2	2	2	

- (5) Read 4 commands [Slave address 1, CH1 Output volume (0014H) to CH4 Output volume (0017H)]
(Reading multiple pieces of data)

- A request message from the master (When reading the above data)

Idle 3.5 characters	Slave address (01H)	Function code (03H)	Data item (0014H)	Amount of data (0004H)	Error check CRC-16 (040DH)	Idle 3.5 characters
	1	1	2	2	2	

- Response message from the slave in normal status

Idle 3.5 characters	Slave address (01H)	Function code (03H)	Response byte count (08H)	Data (03E803E803E803E8H)	
	1	1	1	8	

Error check CRC-16 (5D26H)	Idle 3.5 characters
2	

The data the response message is as follows.

Data Item		Data	Data (Converted to Hexadecimal)
0014H	CH1 Output volume setting	1000	03E8H
0015H	CH2 Output volume setting	1000	03E8H
0016H	CH3 Output volume setting	1000	03E8H
0017H	CH4 Output volume setting	1000	03E8H

11 Communication Command List

11.1 Communication Command List

This section explains each item of communication command.

- Data Item
This is a setting item for the analog I/O module QAM1-4.
- Amount of data
The amount of data that can be handled by each data item.
The amount of setting items for each channel is 4.
The amount of setting items for each module is 1.
- Channel
This is a channel number of the analog I/O module QAM1-4.
- Address [HEX (Hexadecimal), DEC (Decimal)]
This is an each channel address of the analog I/O module QAM1-4.
- Attribute
R/W: Read and write (Host ↔ Analog I/O module QAM1-4)
RO: Read only (Host ← Analog I/O module QAM1-4)
- Data
This is an explanation of the setting range and setting conditions for each data.

Data Item	Amount of data:	Channel	Address		Attribute	Data
			HEX	DEC		
System	4	CH1 CH2 CH3 CH4	0000 0001 0002 0003	0 1 2 3		This is a system item for internal processing. Please do not use.
Reservation (*1)			0004 to 0013			
Output volume setting (*2)	4	CH1 CH2 CH3 CH4	0014 0015 0016 0017	20 21 22 23	R/W	Output scaling low limit to output scaling high limit
Reservation (*1)			0018 to 0083			
Sensor correction factor setting	4	CH1 CH2 CH3 CH4	0084 0085 0086 0087	132 133 134 135	R/W	0.000 to 10.000
Sensor correction setting	4	CH1 CH2 CH3 CH4	0088 0089 008A 008B	136 137 138 139	R/W	-100.0 to 100.0°C (-180.0 to 180.0°F) For direct current input and DC voltage input: -1000 to 1000
PV filter time constant setting	4	CH1 CH2 CH3 CH4	008C 008D 008E 008F	140 141 142 143	R/W	0.0 to 10.0 seconds
Reservation (*1)			0090 to 00C7			

(*1): A single or multiple data are read, the reserved item returns the initial value (0) in acknowledgment.

When writing single or multiple, Acknowledgement is returned and the data is discarded.

(*2): It is not stored in the Non-volatile IC memory.

When the power is turned on, the start value is (0).

Data Item	Amount of data:	Channel	Address		Attribute	Data	
			HEX	DEC			
Input type selection	4	CH1	00C8	200	R/W	For input code M is specified: 0000H: K -200 to 1370°C 0001H: K -200.0 to 400.0°C 0002H: J -200 to 1000°C 0003H: R 0 to 1760°C 0004H: S 0 to 1760°C 0005H: B 0 to 1820°C 0006H: E -200 to 800°C 0007H: T -200.0 to 400.0°C 0008H: N -200 to 1300°C 0009H: PL-Ⅱ 0 to 1390°C 000AH: C(W/Re5-26) 0 to 2315°C 000BH: Pt100 -200.0 to 850.0°C 000CH: 0 to 1 V DC -32768 to 32767 000DH: 4 to 20 mA DC (Externally mounted shunt resistor) -32768 to 32767 000EH: 0 to 20 mA DC (Externally mounted shunt resistor) -32768 to 32767	
		CH2	00C9	201			For input code A is specified: 0000H: 4 to 20 mA DC(Built-in shunt resistor) -32768 to 32767 0001H: 0 to 20 mA DC(Built-in shunt resistor) -32768 to 32767
		CH3	00CA	202			For input code V is specified: 0000H: 0 to 5 V DC -32768 to 32767 0001H: 1 to 5 V DC -32768 to 32767 0002H: 0 to 10 V DC -32768 to 32767
CH4	00CB	203					
Temperature unit selection	4	CH1	00CC	204	R/W	0000H: °C (Celsius) 0001H: °F (Fahrenheit) For input code M is specified, it can be selected.	
		CH2	00CD	205			
		CH3	00CE	206			
		CH4	00CF	207			
Input scaling high limit setting	4	CH1	00D0	208	R/W	-32768 to 32767(*)	
		CH2	00D1	209			
		CH3	00D2	210			
		CH4	00D3	211			
Input scaling low limit setting	4	CH1	00D4	212	R/W	-32768 to 32767(*)	
		CH2	00D5	213			
		CH3	00D6	214			
		CH4	00D7	215			

(*): Enabled for DC voltage input and direct current input.

Data Item	Amount of data:	Channel	Address		Attribute	Data
			HEX	DEC		
Input sampling cycle selection	4	CH1	00D8	216	R/W	0000H: 125 ms 0001H: 50 ms 0002H: 20 ms Fixed to 125 ms for thermocouple input and RTD input. It becomes invalid if a value other than 125 ms is selected.
		CH2	00D9	217		
		CH3	00DA	218		
		CH4	00DB	219		
Reservation (*1)			00DC to 0107			
Number of moving average setting	4	CH1	0108	264	R/W	1 to 10 times
		CH2	0109	265		
		CH3	010A	266		
		CH4	010B	267		
Reservation (*1)			010C to 01B7			
Output scaling high limit setting	4	CH1	01B8	440	R/W	-32768 to 32767
		CH2	01B9	441		
		CH3	01BA	442		
		CH4	01BB	443		
Output scaling low limit setting	4	CH1	01BC	444	R/W	-32768 to 32767
		CH2	01BD	445		
		CH3	01BE	446		
		CH4	01BF	447		
Reservation (*1)			01C0 to 01F3			
Communication response delay time setting (*2)	1		01F4	500	R/W	0 to 1000 ms
Reservation (*1)			01F5 to 020B			
Host setting value change flag clearing selection	1		020C	524	R/W	0000H: Clear 0001H: Do not clear (Change setting value)
USB setting value change flag clearing selection	1		020D	525	R/W	0000H: Clear 0001H: Do not clear (Change setting value)

(*1): A single or multiple data are read, the reserved item returns the initial value (0) in acknowledgment.

(*2): When connecting to the communication expansion module QMC1, set the communication response delay time to 0 ms (initial value).

Data Item	Amount of data:	Channel	Address		Attribute	Data
			HEX	DEC		
PV reading	4	CH1 CH2 CH3 CH4	03E8 03E9 03EA 03EB	1000 1001 1002 1003	RO	Reading value (decimal point omitted) (*1)
Output value reading	4	CH1 CH2 CH3 CH4	03EC 03ED 03EE 03EF	1004 1005 1006 1007	RO	Reading value (decimal point omitted) 0.00 to 100.00 %
Reservation (*1)			03F0 to 03F3			
Status flag 1 reading	4	CH1 CH2 CH3 CH4	03F4 03F5 03F6 03F7	1012 1013 1014 1015	RO	B0 to B2: Not used (indefinite) B3: Output volume is out of setting range 0: Normal 1: Error ON B4: Input error (Overscale) 0: Normal 1: Error B5: Input Error (Underscale) 0: Normal 1: Error B6 to B13: Not used (indefinite) B14: Power supply identification (*2) 0: 24 V DC 1: USB bus power B15: Non-volatile IC memory error 0: Normal 1: Error

(*1): When power is supplied from the host computer by USB bus power, 0 is returned.

(*2): When power is supplied from 24 V DC and USB bus power, 0: 24 V DC is returned.

Data Item	Amount of data:	Channel	Address		Attribute	Data
			HEX	DEC		
Status flag 2 reading	4	CH1 CH2 CH3 CH4	03F8 03F9 03FA 03FB	1016 1017 1018 1019	RO	B0 to B3: Not used (indefinite) B4: Cold junction error 0: Normal 1: Error B5: Sensor error 0: Normal 1: Error B6: ADC error 0: Normal 1: Error B7: Host setting value change flag (*1) 0: Without flag 1: With flag B8: USB setting value change flag (*2) 0: Without flag 1: With flag B9 to B15: Not used (indefinite)
Reservation (*1)			03FC to 0407			
PV reading (true value)	4	CH1 CH2 CH3 CH4	0408 0409 040A 040B	1032 1033 1034 1035	RO	Reading value (decimal point omitted) (*3)
Ambient temperature reading	4	CH1 CH2 CH3 CH4	040C 040D 040E 040F	1036 1037 1038 1039	RO	Reading value (decimal point omitted) Read the input terminal temperature of each channel. (*4)

(*1): The Host setting value change flag sets "1: With flag" to B7: Host setting value change flag when the set value is changed by the host communication side.

When clear (0000H) is received with the Host setting value change flag clear selection (020CH), B7: Host setting value change flag is set to "0: Without flag".

(*2): The USB setting value change flag sets "1: With flag" to B8: USB setting value change flag when the set value is changed by the USB communication side.

When clear (0000H) is received with the USB setting value change flag clear selection (020DH), B8: USB setting value change flag is set to "0: Without flag".

(*3): When power is supplied from the host computer by USB bus power, 0 is returned.

(*4): When thermocouple input, convert it to a value according to temperature unit selection.

For the read value, the value of the first decimal place is returned regardless of the presence or absence of a decimal point in the input range.

(Example) If 0.0 °C (32.0 °F), the read value will be 0 (320).

When RTD input, direct current input, and DC voltage input, 0 is returned.

Data Item	Amount of data:	Channel	Address		Attribute	Data
			HEX	DEC		
Alarm history 1 Error No.	4	CH1	044C	1100	RO	B0 to B6: Not used (indefinite) B7: Sensor error 0: Normal 1: Error B8: Input error (Overscale) 0: Normal 1: Error B9: Input error (Underscale) 0: Normal 1: Error B10: Cold junction error 0: Normal 1: Error B11: Non-volatile IC memory error 0: Normal 1: Error B12: ADC error 0: Normal 1: Error B13: Not used (indefinite) B14: Not used (indefinite) B15: Not used (indefinite)
		CH2	044D	1101		
		CH3	044E	1102		
		CH4	044F	1103		
Alarm history 2 Error No.	4	CH1	0450	1104	RO	
		CH2	0451	1105		
		CH3	0452	1106		
		CH4	0453	1107		
Alarm history 3 Error No.	4	CH1	0454	1108	RO	
		CH2	0455	1109		
		CH3	0456	1110		
		CH4	0457	1111		
Alarm history 4 Error No.	4	CH1	0458	1112	RO	
		CH2	0459	1113		
		CH3	045A	1114		
		CH4	045B	1115		
Alarm history 5 Error No.	4	CH1	045C	1116	RO	
		CH2	045D	1117		
		CH3	045E	1118		
		CH4	045F	1119		
Alarm history 6 Error No.	4	CH1	0460	1120	RO	
		CH2	0461	1121		
		CH3	0462	1122		
		CH4	0463	1123		
Alarm history 7 Error No.	4	CH1	0464	1124	RO	
		CH2	0465	1125		
		CH3	0466	1126		
		CH4	0467	1127		
Alarm history 8 Error No.	4	CH1	0468	1128	RO	
		CH2	0469	1129		
		CH3	046A	1130		
		CH4	046B	1131		
Alarm history 9 Error No.	4	CH1	046C	1132	RO	
		CH2	046D	1133		
		CH3	046E	1134		
		CH4	046F	1135		
Alarm history 10 Error No.	4	CH1	0470	1136	RO	
		CH2	0471	1137		
		CH3	0472	1138		
		CH4	0473	1139		

Data Item	Amount of data:	Channel	Address		Attribute	Data
			HEX	DEC		
Alarm history 1 Total energizing time	4	CH1	0474	1140	RO	Total energizing time when an error occurs
		CH2	0475	1141		
		CH3	0476	1142		
		CH4	0477	1143		
Alarm history 2 Total energizing time	4	CH1	0478	1144	RO	
		CH2	0479	1145		
		CH3	047A	1146		
		CH4	047B	1147		
Alarm history 3 Total energizing time	4	CH1	047C	1148	RO	
		CH2	047D	1149		
		CH3	047E	1150		
		CH4	047F	1151		
Alarm history 4 Total energizing time	4	CH1	0480	1152	RO	
		CH2	0481	1153		
		CH3	0482	1154		
		CH4	0483	1155		
Alarm history 5 Total energizing time	4	CH1	0484	1156	RO	
		CH2	0485	1157		
		CH3	0486	1158		
		CH4	0487	1159		
Alarm history 6 Total energizing time	4	CH1	0488	1160	RO	
		CH2	0489	1161		
		CH3	048A	1162		
		CH4	048B	1163		
Alarm history 7 Total energizing time	4	CH1	048C	1164	RO	
		CH2	048D	1165		
		CH3	048E	1166		
		CH4	048F	1167		
Alarm history 8 Total energizing time	4	CH1	0490	1168	RO	
		CH2	0491	1169		
		CH3	0492	1170		
		CH4	0493	1171		
Alarm history 9 Total energizing time	4	CH1	0494	1172	RO	
		CH2	0495	1173		
		CH3	0496	1174		
		CH4	0497	1175		
Alarm history 10 Total energizing time	4	CH1	0498	1176	RO	
		CH2	0499	1177		
		CH3	049A	1178		
		CH4	049B	1179		

Data Item	Amount of data:	Channel	Address		Attribute	Data
			HEX	DEC		
Reservation (*)			049C to 04A3			
Total energizing time (High, Low)	4	(上位) (下位)	04A4 04A5 04A6 04A7	1188 1189 1190 1191	RO	Total energizing time 1 count/10 min 1190, 1191 is always 0.
Reservation (*)			04A8 to 04AF			
Output form	4	CH1 CH2 CH3 CH4	04B0 04B1 04B2 04B3	1200 1201 1202 1203	RO	0000H: 0001H: 0002H: 0003H: 0004H: DC current output 4 to 20 mA DC 0005H: DC current output 4 to 20 mA DC 0006H: DC voltage output 0 to 1 V DC 0007H: DC voltage output 0 to 5 V DC 0008H: DC voltage output 1 to 5 V DC 0009H: DC voltage output 0 to 10 V DC
Input form	4	CH1 CH2 CH3 CH4	04B4 04B5 04B6 04B7	1204 1205 1206 1207	RO	0000H: Input code M 0001H: Input code A 0002H: Input code V
Product code	1		04B8	1208	RO	Product code
Presence of communication option	1		04B9	1209	RO	0000H: No option 0001H: With power supply/host communication function
Wiring type	1		04BA	1210	RO	0000H: Terminal type 0001H: Connector type
I/O type	1		04BB	1211	RO	0000H: Input only (AI) 0001H: Output only (AO) 0002H: Input/output (AIO)
Presence of event option	1		04BC	1212	RO	0000H: No option
Software version	1		04BD	1213	RO	Software version
Manufacturing date	1		04BE	1214	RO	Manufacturing date (e.g. 2009: September 2020)
Hardware version	1		04BF	1215	RO	Hardware version
Reservation (*)			04C0 to 052C			

(*): A single or multiple data are read, the reserved item returns the initial value (0) in acknowledgment.

When writing single or multiple, Acknowledgement is returned and the data is discarded.

11.2 Data

11.2.1 Notes About Write/Read Command

- The data (set value, decimal) is converted to a hexadecimal number. Negative numbers are represented in 2's complement.
- Do not use undefined Data items. If they are used, negative acknowledgement will be returned or a random value will be written or read, resulting in malfunction.
- MODBUS protocol uses Holding Register addresses. The Holding Register addresses are created as follows.

A data item is converted to decimal number, and the offset of 40001 is added. The result is the Holding Register address.

Using CH1 Output volume setting (0014H) as an example: Data item in the sending message is 0014H, however, MODBUS protocol Holding Register address is 40021 (20+40001).

11.2.2 Write Command

- The lifetime of the non-volatile IC memory is about 1 trillion times. Do not change the set value frequently by communication, as the set value storage retention time may be shortened if the number of times is exceeded. (If the set value is the same as the value before setting, it is not written to the non-volatile IC memory.)
- When data (set value) has a decimal point, a whole number (hexadecimal) without a decimal point is used.
- Communication parameters such as module address and communication speed of this instrument cannot be written by software communication. Set it with the rotary switch for module address selection and the dip switch for selecting communication specifications.
- When Write is executed using the Broadcast address [(00H) MODBUS protocol] command, the command is sent to all the connected slaves. However, a response is not returned.

11.2.3 Read Command

- When the data (set value) has a decimal point, a whole number (hexadecimal) without a decimal point is used for a response.

11.3 Negative Acknowledgement

11.3.1 Error Code 2 (02H)

The slave will return Error code 2 (02H) in the following case.

- When non-existent data item is read or written.

11.3.2 Error Code 3 (03H)

The slave will return Error code 3 (03H) in the following case.

- When a value out of the setting range is written.

11.3.3 Error Code 17 (11H)

The slave will return Error code 17 (11H) in the following case.

- In the case of a condition that cannot be written.

11.4 Notes on Programming Monitoring Software

11.4.1 How to Speed up the Scan Time

When monitoring multiple this instrument, set the program so that the requisite minimum pieces of data such as PV (03E8H to 03EBH), Output volume (03ECH to 03EFH), Status flag 1 (03F4H to 03F7H) can be read.

For other data, set the program so that they can be read only when their set value has changed.

This will speed up the scan time.

11.4.2 Notes on Batch Transmission of All Setting Values

- If the input type is changed with Input type (00C8H to 00CBH), the setting values such as Sensor correction factor, Input scaling high / low limit, and Output scaling high / low limit are initialized.

Send the Input type and then the other setting values.

For the items to be initialized, refer to “11.5 Initialization Items by Changing Settings”.

11.5 Initialization Items by Changing Settings

The items that are initialized by changing the settings are shown below.

○: Initialize

–: Not initialize

Setting change item Initialized item	Input type (00C8H to 00CBH)	Temperature unit (00CCH to 00CFH)
Sensor correction factor (0084H to 0087H)	○	○
Sensor correction (0088H to 008BH)	○	○
Input scaling high limit (00D0H to 00D3H)	○	○
Input scaling low limit (00D4H to 00D7H)	○	○
Output scaling high limit (01B8H to 01BBH)	○	○
Output scaling low limit (01BCH to 01BFH)	○	○

12 Operation

This section describes the operation when operating by communicating with the host computer. Refer to “11.1 Communication Command List (P.11-1)” for setting the control parameters such as Output volume, Input scaling high / low limit, and Output scaling high / low limit required for operation.

12.1 Start measurement

(1) Before turning the power ON

Check the following contents before turning the power ON to this instrument.

- Preparation of communication program
A communication program is required to connect and use the host computer.
Refer to “10 MODBUS Protocol (P.10-1)” to create the communication program.
- Select communication specifications
Select the communication specifications such as communication speed, data bit, and parity.
Refer to “5.1.1 Selection of Communication Specifications (P.5-1)”.
- Setting module address
Set the module address.
Refer to “5.1.2 Setting of Module Address (P.5-3)”.
- Mounting
Mount the analog I/O module QAM1-4 to the DIN rail.
Refer to “6 Mounting (P.6-1)”.
- Wiring
Wire the analog I/O module QAM1-4.
Refer to “7 Wiring (P.7-1)”.
- Connection of host computer and analog I/O module QAM1-4
Connect the host computer and analog I/O module QAM1-4.
Refer to “7.5 Connection of Host Computer and Analog I/O Module QAM1-4 (P.7-7)”.

(2) After turning the power ON

Check the following contents after turning the power ON to this instrument.

- Specification setting
Set specifications such as input parameters and output parameters.
Refer to “8 Setting of Specification (P.8-1)”.

(3) Turn OFF → ON the QAM1-4 power

Turn OFF → ON the power of QAM1-4. The set value becomes effective.

(4) Operation

Start measurement.

Refer to “11.1 Communication Commands List (P.11-1)” to perform communication.

Read [Slave address 1, CH1 PV (03E8H)]

- A request message from the master

Idle 3.5 characters	Slave address (01H)	Function code (03H)	Data item (03E8H)	Amount of data (0001H)	Error check CRC-16 (09CBH)	Idle 3.5 characters
	1	1	2	2	2	

- Response message from the slave in normal status [When PV=600°C (0258H)]

Idle 3.5 characters	Slave address (01H)	Function code (03H)	Response byte count (02H)	Data (0258H)	Error check CRC-16 (B8DEH)	Idle 3.5 characters
	1	1	1	2	2	

Write [Slave address 1, CH1 Output volume (0014H)]

- A request message from the master [When Output volume 1000 (03E8H)]

Idle 3.5 characters	Slave address (01H)	Function code (06H)	Data item (0014H)	Data (03E8H)	Error check CRC-16 (C970H)	Idle 3.5 characters
	1	1	2	2	2	

- Response message from the slave in normal status

Idle 3.5 characters	Slave address (01H)	Function code (06H)	Data item (0014H)	Data (03E8H)	Error check CRC-16 (C970H)	Idle 3.5 characters
	1	1	2	2	2	

12.2 Correct PV

When a sensor cannot be mounted at a location to be controlled, the temperature measured by the sensor may differ from the temperature at the measurement location.

Also, when multiple analog I/O modules are used for measurement, the measured temperatures may not match due to the accuracy of the sensors.

In such cases, the temperature measured by the sensor can be corrected to match the PV of the analog I/O module with the desired temperature.

The input value is corrected by the sensor correction factor and the sensor correction.

The sensor correction factor sets the slope, and the sensor correction sets the difference between before and after correction.

PV after input correction is expressed by the following formula.

PV after input correction =

Current PV × Sensor correction factor setting value + (Sensor correction setting value)

An example of input value correction using a combination of Sensor correction factor and Sensor correction is shown below.

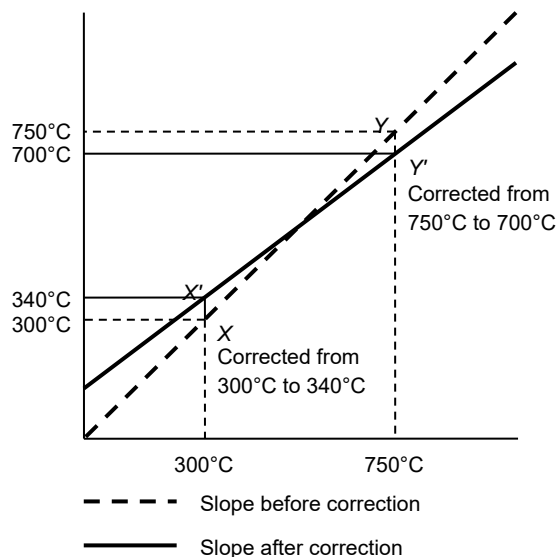

(Fig. 12.2-1)

- (1) Extract two points to be corrected and determine the PV after correction.
Before correction: 300°C → After correction: 340°C
Before correction: 750°C → After correction: 700°C
- (2) Find the sensor correction factor setting value from (1).
 $(Y' - X') / (Y - X) = (700 - 340) / (750 - 300) = 0.8$
- (3) It is input so that PV will be 300°C using a mV generator and dial resistor.
- (4) Set the value of (2) to the sensor correction factor.
- (5) Read PV.
It is displayed as 240°C.
- (6) Find the sensor correction setting value.
Find the difference between the PV after input correction and the PV read in (5).
 $340°C - 240°C = 100°C$
- (7) Set the value of (6) to the sensor correction.
- (8) Input an electromotive force or resistance value equivalent to 750°C using a mV generator or dial resistor.
- (9) Read PV and check that the display is 700°C.

[Setting Example] When set Sensor correction factor: 0.800, Sensor correction: 100.0°C

0.800(0320H) [Slave address 1, Sensor correction factor of CH1]

- A request message from the master

Idle 3.5 characters	Slave address (01H)	Function code (06H)	Data item (0084H)	Data (0320H)	Error check CRC-16 (C8CBH)	Idle 3.5 characters
	1	1	2	2	2	

- Response message from the slave in normal status

Idle 3.5 characters	Slave address (01H)	Function code (06H)	Data item (0084H)	Data (0320H)	Error check CRC-16 (C8CBH)	Idle 3.5 characters
	1	1	2	2	2	

100.0°C (03E8H) [Slave address 1, Sensor correction of CH1]

- A request message from the master

Idle 3.5 characters	Slave address (01H)	Function code (06H)	Data item (0088H)	Data (03E8H)	Error check CRC-16 (095EH)	Idle 3.5 characters
	1	1	2	2	2	

- Response message from the slave in normal status

Idle 3.5 characters	Slave address (01H)	Function code (06H)	Data item (0084H)	Data (03E8H)	Error check CRC-16 (095EH)	Idle 3.5 characters
	1	1	2	2	2	

13 Communication with PLC Using SIF Function

The SIF function (Smart InterFace, programless communication function) is a function that serially connects the PLC Q series (manufactured by Mitsubishi Electric Corp.) and this instrument, and reads and writes various data to and from PLC registers using the communication protocol of the PLC.

The following communication protocols and commands are supported.

Communication protocol	Format 4
Communication command	A compatible 1C frame AnA/AnU common command (QR/QW)

Using the console software (SWC-QTC101M), select the PLC register start number, PLC register address, the monitoring items and setting items to be linked, and set the specifications.

The control module QTC1-2P (with power supply / communication options) or QTC1-4P (with power supply / communication options) becomes the master and the selected monitor item is periodically written to the PLC register using the QW command, and the PLC register value is constantly updated.

In addition, the selected setting items are read from the PLC register in response to a setting request using the QR command.

When the read data is changed, the set value of control module QTC1-2P (with power / communication option) or QTC1-4P (with power supply / communication option) and analog I/O module QAM1-40 (no power supply / communication option) is updated.

Configuration example of PLC and QTC1-4P, QAM1-40

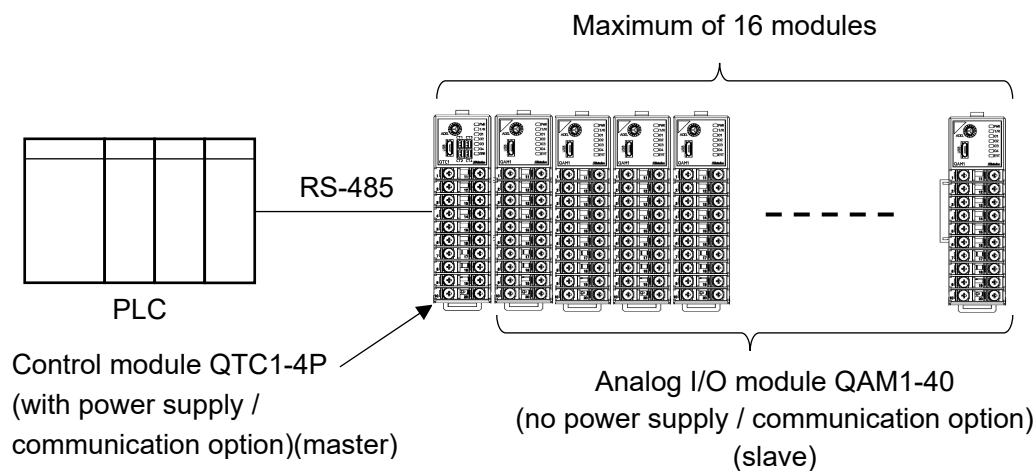

(Fig. 13-1)

13.1 Flow of Before Operation

The flow of operation when the QTC1-4P and QAM1-40 are connected to the PLC is shown below.

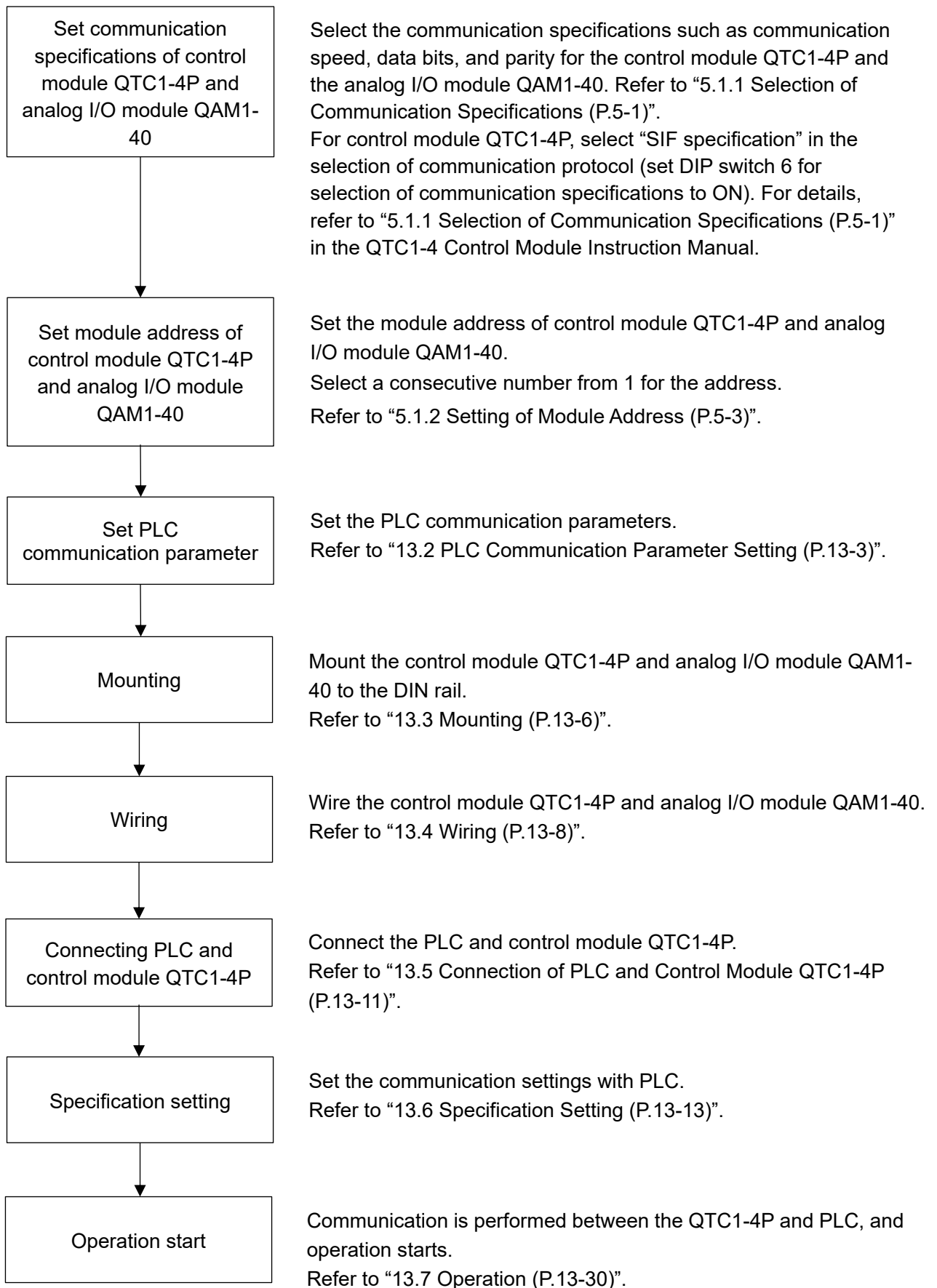

(Fig. 13.1-1)

13.2 PLC Communication Parameter Setting

Set the PLC communication parameters.

The setting method using GX Works3 is explained.

Connect the GX Works3 installed PC, set the communication speed, transmission specifications, communication protocol, etc., and then set the communication parameters using the PC write function. Refer to “Serial Communication Module User's Manual (Basic)” for detail.

(1) I/O assignment setting

Double-click [PLC parameter] on Project data list -> Parameter.

Display the Parameter Setting screen.

Click “I/O Assignment” tab, and set “Type”, “Model Name” and “Points”.

The screenshot shows the 'Q Parameter Setting' dialog box with the 'I/O Assignment' tab selected. The 'I/O Assignment(*1)' table is as follows:

No.	Slot	Type	Model Name	Points	Start XY
0	PLC	PLC			
1	0(0-0)	Intelligent	QJ71C24N	32Points	
2	1(0-1)				
3	2(0-2)				
4	3(0-3)				
5	4(0-4)				
6	5(0-5)				
7	6(0-6)				

Below the table, the 'Base Setting(*1)' section is visible:

	Base Model Name	Power Model Name	Extension Cable	Slots
Main				8
Ext.Base1				
Ext.Base2				
Ext.Base3				
Ext.Base4				

Buttons at the bottom include: 'Export to CSV File', 'Import Multiple CPU Parameter', 'Read PLC Data', 'Print Window...', 'Print Window Preview', 'Acknowledge XY Assignment', 'Default', 'Check', 'End', and 'Cancel'.

(Fig. 13.2-1)

[Setting Example]

Setting item	Setting contents
Type	Intelligent
Model Name	Model name of mounted unit (Example: QJ71C24N)
Points	32 points

(2) Switch setting

Click [Switch Setting] button to the right of the I/O Assignment setting.

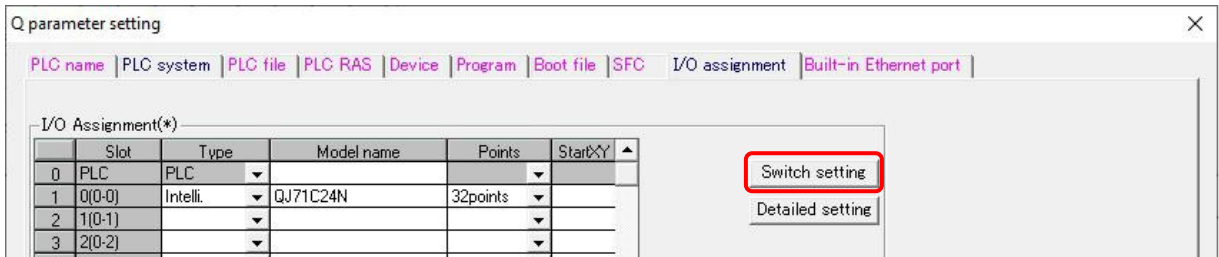

(Fig. 13.2-2)

Displays the Switch Setting for I/O and Intelligent Function Module screen.

Set the data bit, parity bit, stop bit, communication speed and communication protocol settings.

After setting, click [End] button.

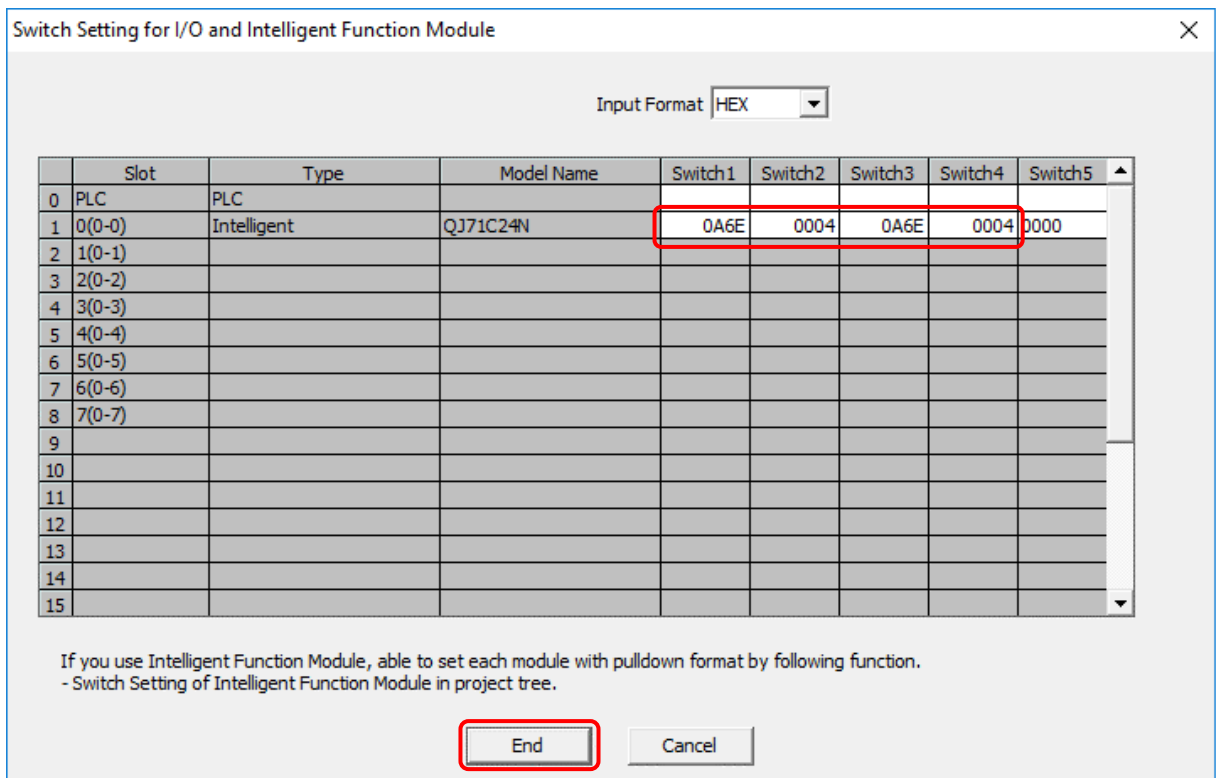

(Fig. 13.2-3)

[Setting Example]

Setting item	Setting contents
Action setting	Independent
Data bit	8 bits
Parity bit	Even
Stop bit	1 bit
Sum check code	Yes
Write during RUN	Enable
Setting change	Disable
Communication speed setting	Set the same communication speed as the control module QTC1-4P (Setting example: 57600 bps)
Communication protocol setting	Format 4

(3) PLC writing

Click [Write to PLC...] on Menu bar -> Online.

Display the PC writing screen.

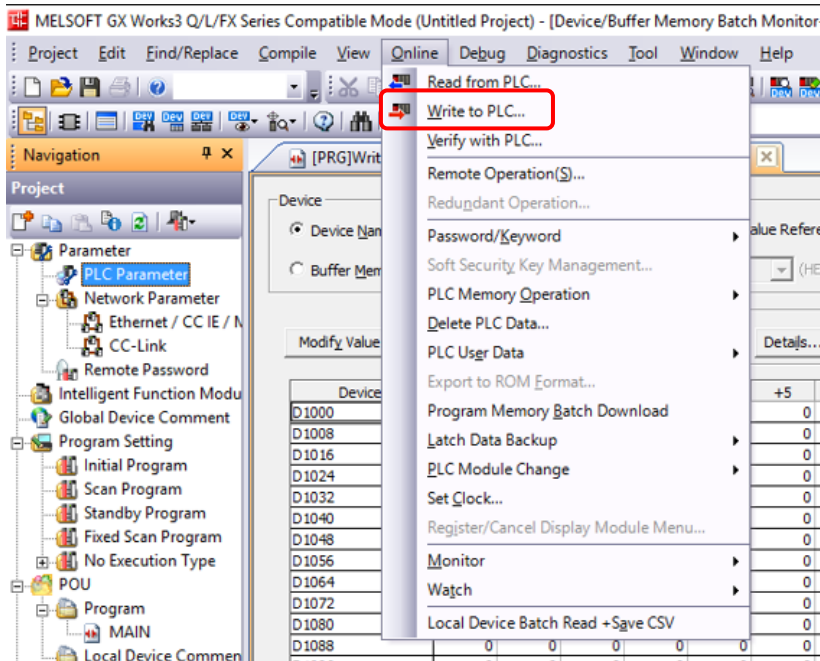

(Fig. 13.2-4)

Click [Select all] button -> [Execute] button.

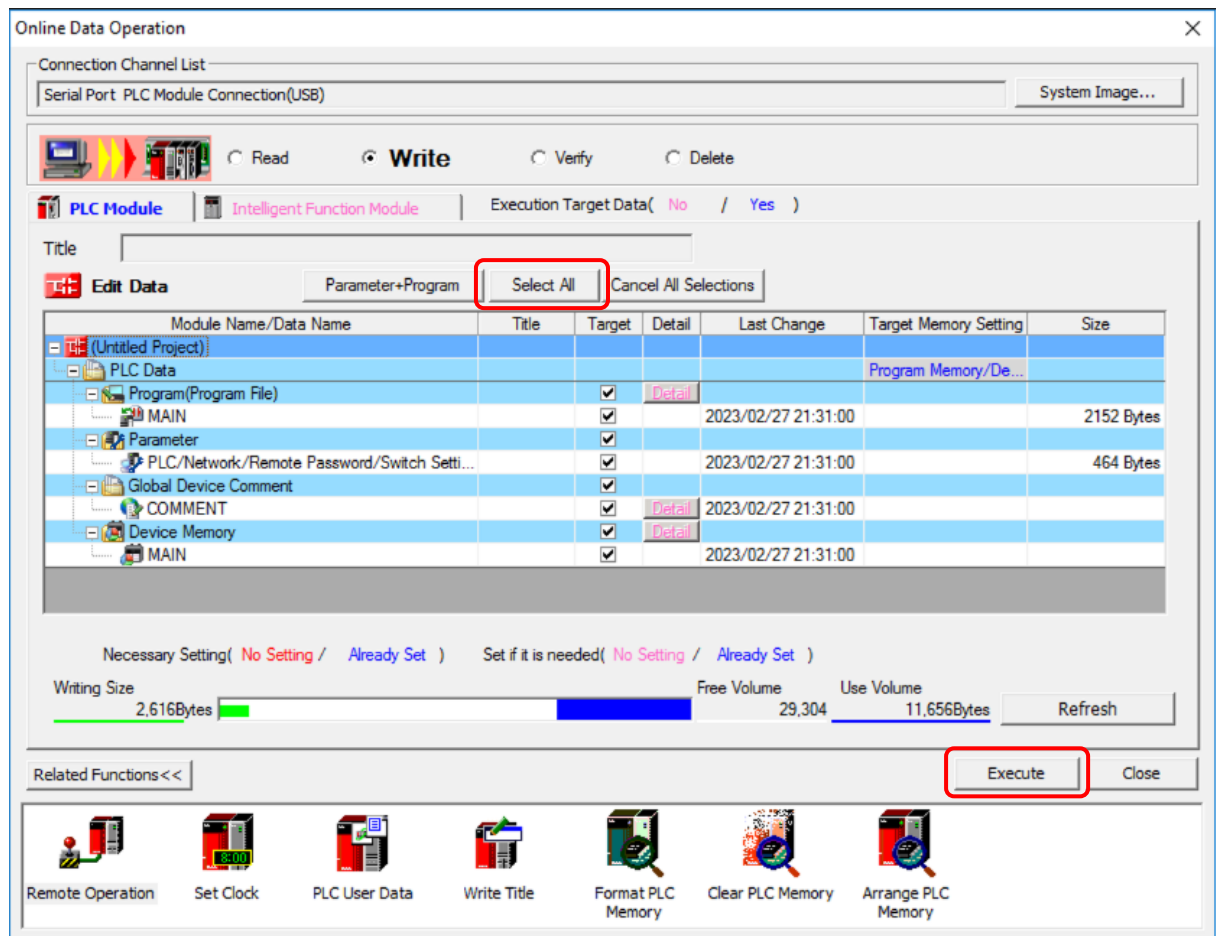

(Fig. 13.2-5)

This completes the PLC communication parameter settings.

13.3 Mounting

Mounting to the DIN rail

- ① Lower the lock lever of this instrument. (The lock lever of this instrument has a spring structure, but if lower it in the direction of the arrow until it stops, it will be locked in that position.)
- ② Hook the part ② of this instrument onto the top of the DIN rail.
- ③ Insert the lower part of this instrument with the part ② as a fulcrum.
- ④ Raise the lock lever of this instrument.

Make sure it is fixed to the DIN rail.

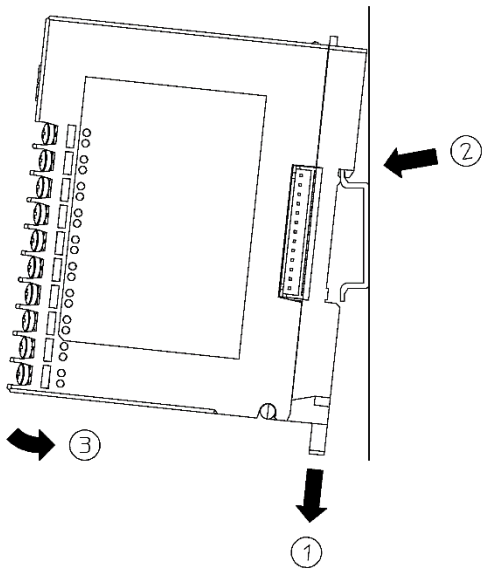

(Fig. 13.3-1)

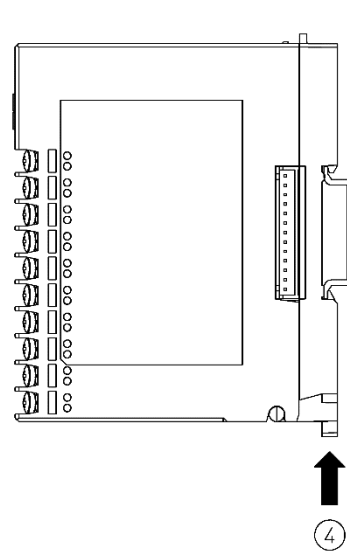

(Fig. 13.3-2)

Removal from the DIN rail

- ① Insert a flat blade screwdriver into the lock lever of this instrument and lower the lock lever until it stops.
- ② Remove this instrument from the DIN rail by lifting it from below.

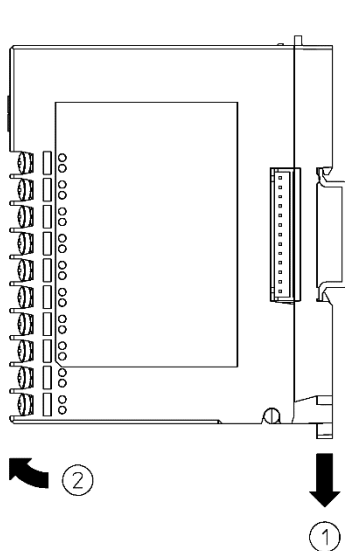

(Fig. 13.3-3)

Mounting multiple modules to the DIN rail

This section describes an example of mounting multiple modules on the DIN rail.

- ① Remove the line cap on the right side of the QTC1-4P.
- ② Lower the lock lever of the QAM1-40, and mounting the QAM1-40 to the DIN rail.
- ③ Slide the QAM1-40 to the left and connect the connectors to each other.
- ④ Raise the lock lever of the QAM1-40.

Make sure it is fixed to the DIN rail.

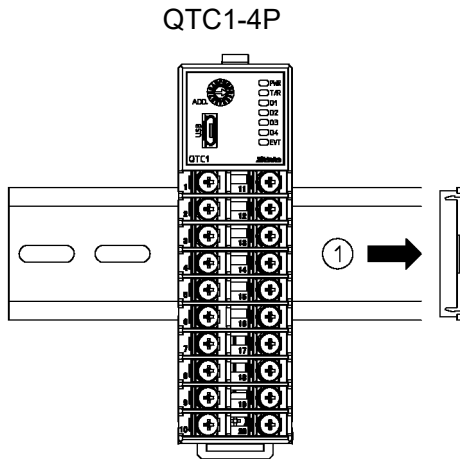

(Fig. 13.3-4)

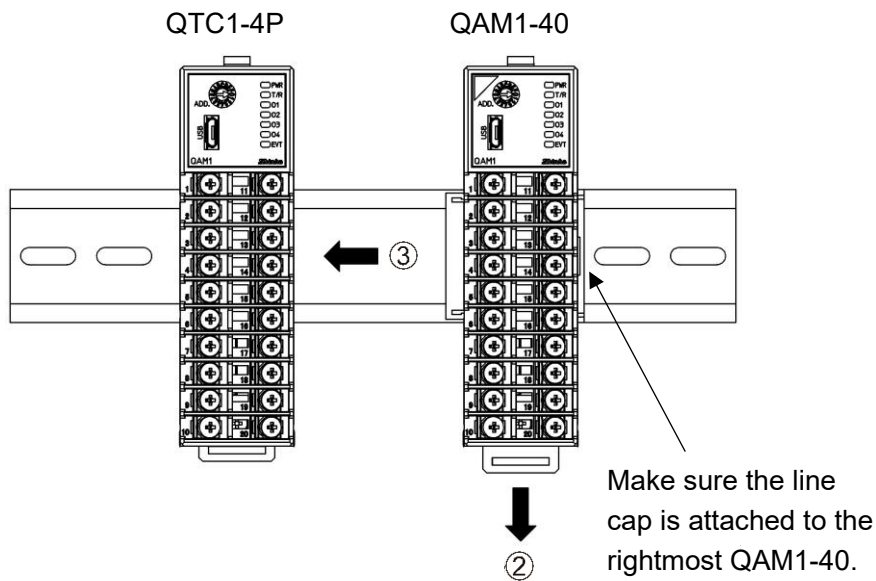

(Fig. 13.3-5)

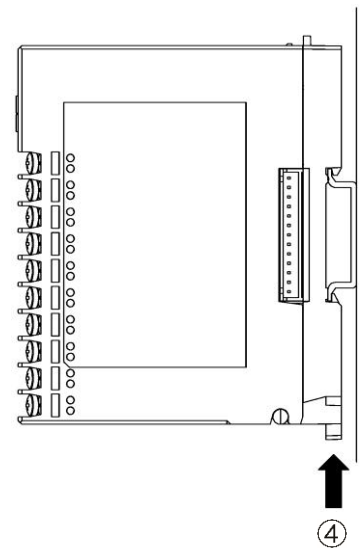

(Fig. 13.3-6)

13.4 Wiring

13.4.1 Wiring for Power Supply and Communication

The terminal block for power supply and communication is located on the base of the control module QTC1-4P.

Wiring by the following procedure.

(1) Case removal

- ① Push the release lever on the top of QTC1-4P to unlock it.
- ② Remove the case.

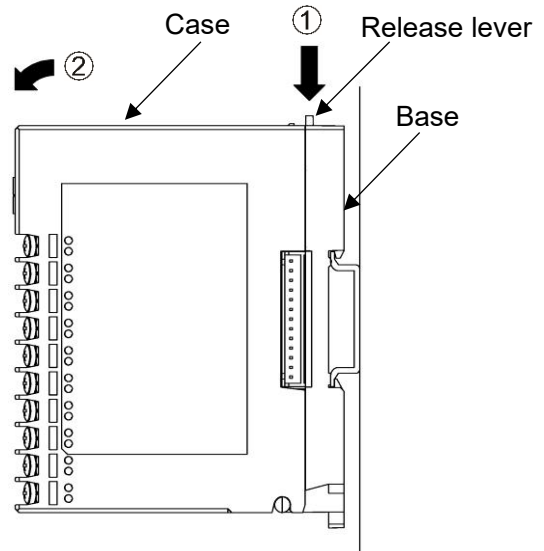

(Fig. 13.4.1-1)

(2) Wiring

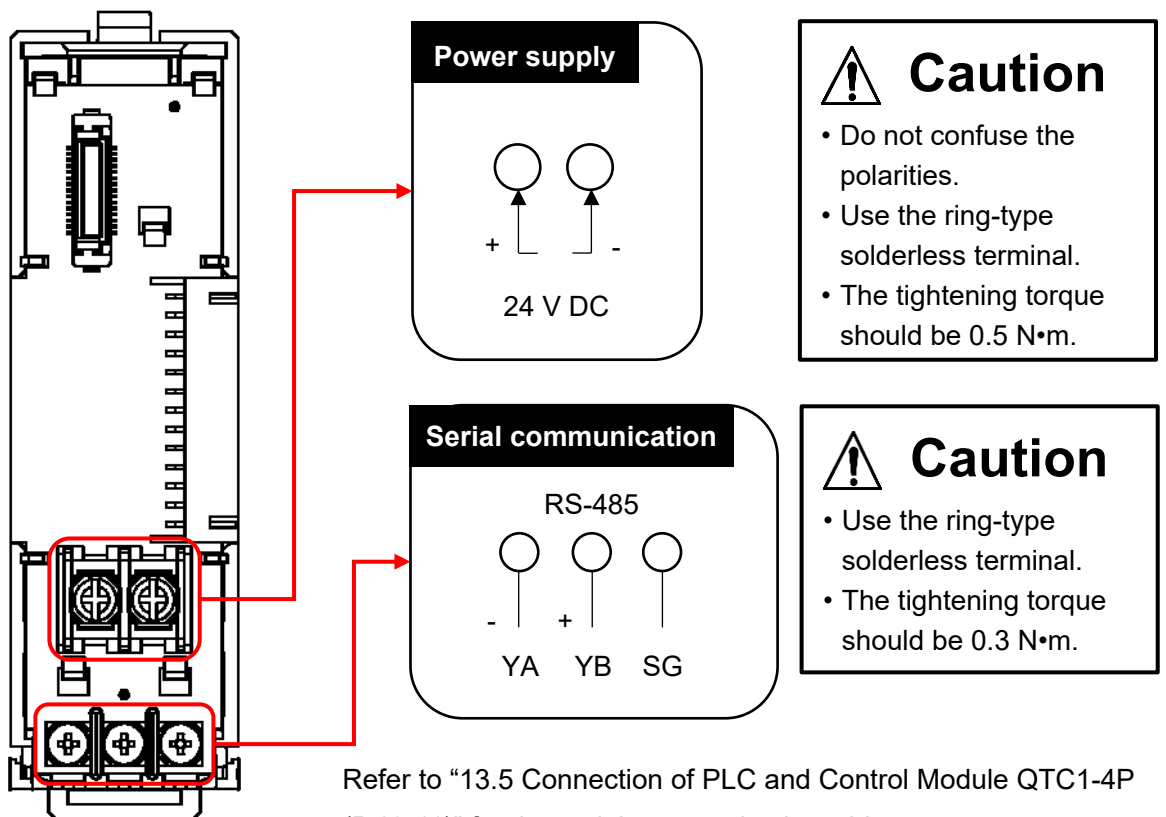

(Fig. 13.4.1-2)

(3) Case mounting

① Hook the case on the lower part ① of QTC1-4P.

② Mount the case so that the lower part ① of QTC1-4P is the fulcrum and covers the release lever.

There is a clicking sound.

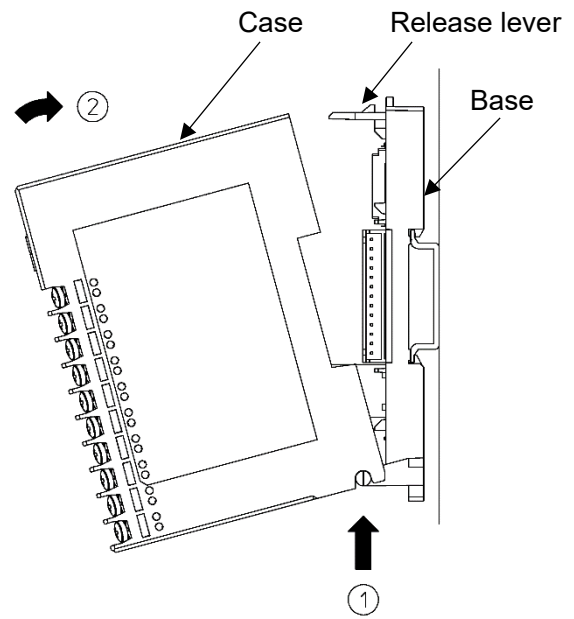

(Fig. 13.4.1-3)



Caution

- Please note that CH1, CH2 and CH3, CH4 have different terminal arrangements.
- The tightening torque should be 0.63 N•m.
- For DC current input (with an external receiving resistor), connect a receiving resistor [option 50 Ω (RES-S01-050)] between each input terminal (+ and -). For DC current input (built-in receiving resistor), a receiving resistor (50 Ω) is not required.

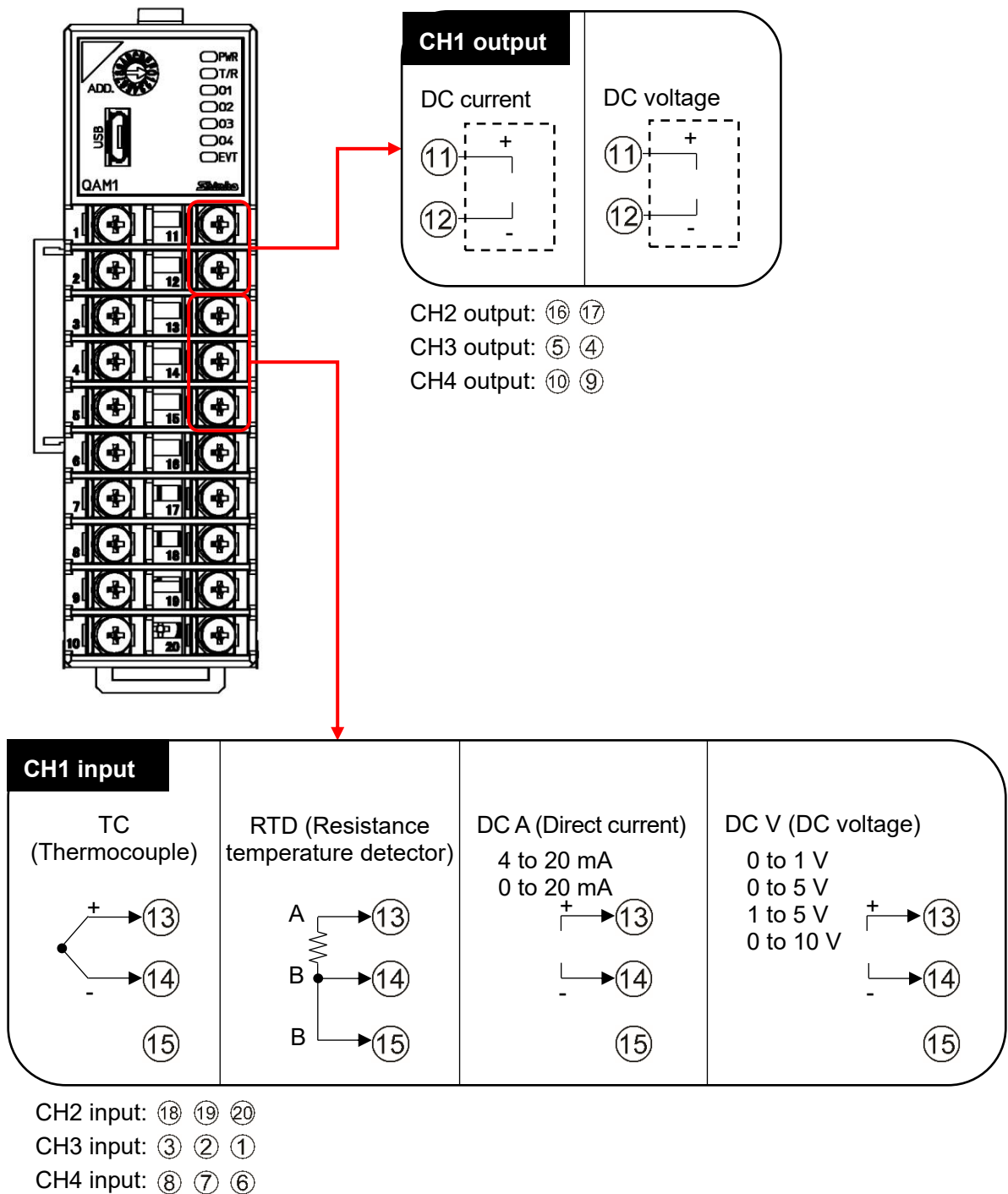

(Fig. 13.4.2-1)

13.5 Connection of PLC and Control Module QTC1-4P

Warning

Turn off the power supply to this instrument before wiring.

If you work while the power is supplied, you may get an electric shock, which could result in an accident resulting in death or serious injury.

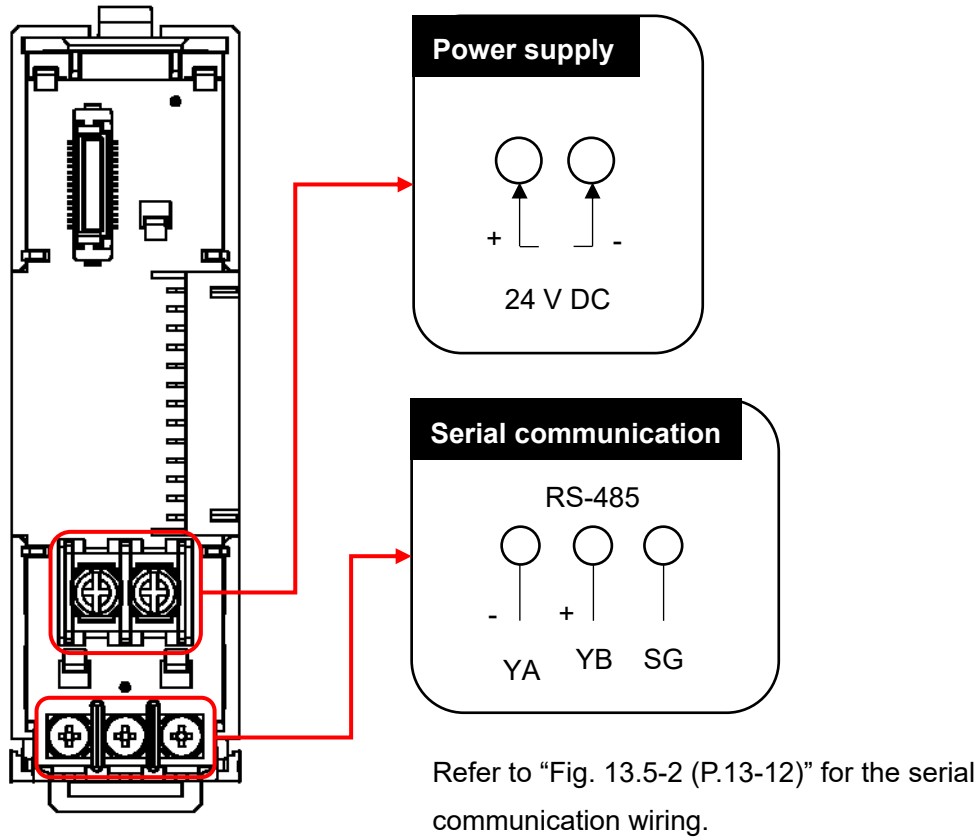

(Fig. 13.5-1)

Example of connection between PLC and QTC1-4P, QAM1-40

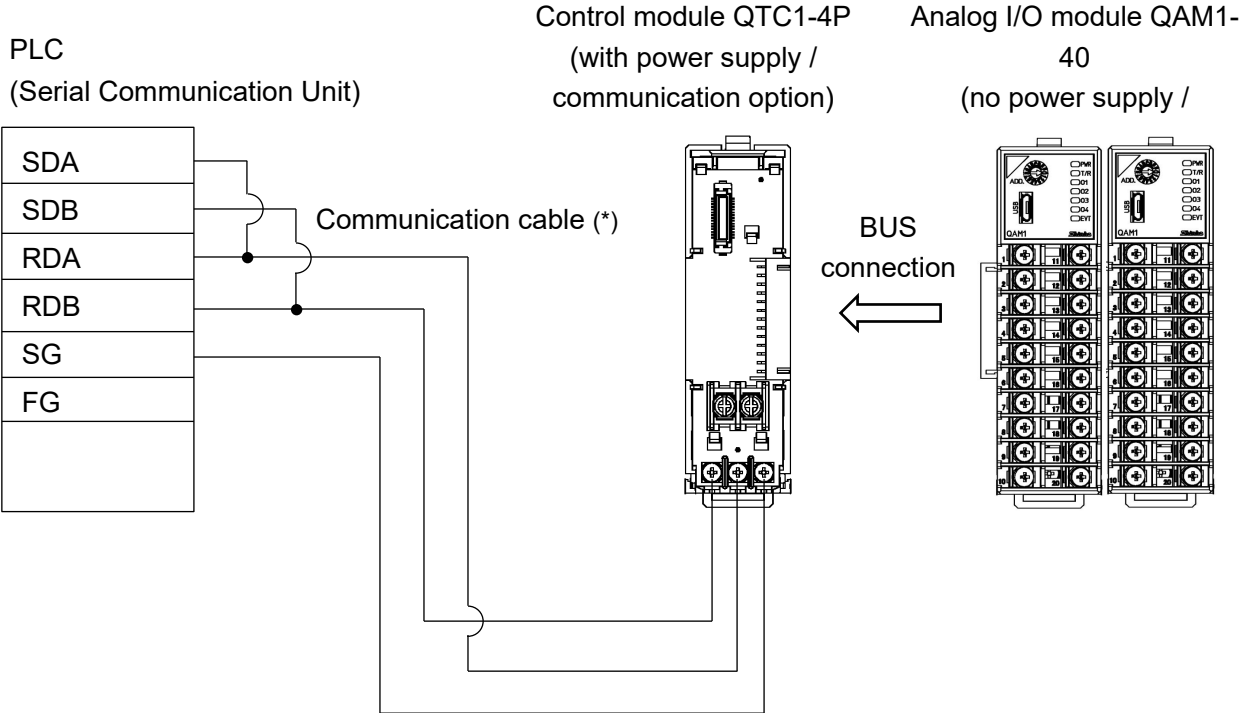

(*): For communication cables, please contact the store where you purchased the product or our sales office.

(Fig. 13.5-2)

13.6 Specification Setting

Set the specifications of the control module QTC1-4P and analog I/O module QAM1-40 to communicate with the PLC.

This section describes how to set specifications using console software (SWC-QTC101M).

13.6.1 Preparation of USB Communication Cable and Console Software

Please prepare the USB communication cable and the console software.

- USB communication cable
USB-micro USB Type-B (commercial item)
- Console software (SWC-QTC101M)
Please download from our website and install.
Click <https://shinko-technos.co.jp/e/> → Support/Download → Software

13.6.2 Connecting to Host Computer



Caution

Do not use the logging function of the console software when communicating by connecting the USB communication cable.

- (1) Connect the micro USB Type-B side of the USB communication cable to the console communication connector of this instrument.
- (2) Connect the USB plug of the USB communication cable to the USB port of the host computer.

Example of connection between host computer and QTC1-4P, QAM1-40

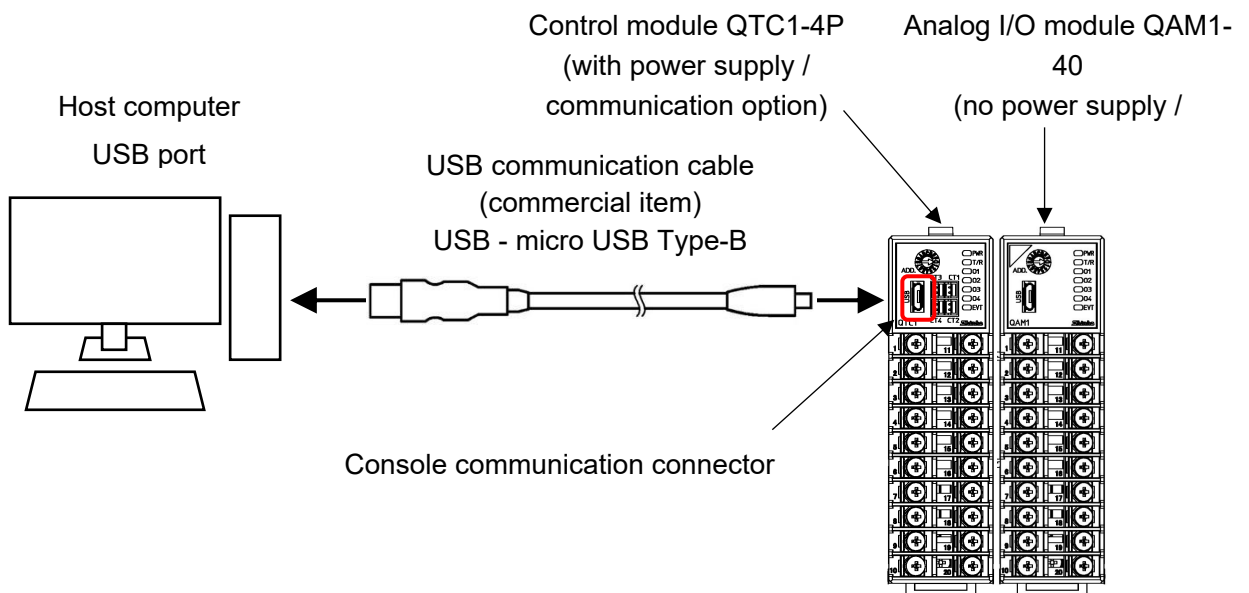

(Fig. 13.6.2-1)

(3) Checking the COM port number

Follow the procedure below to check the COM port number.

- ① Right-click "Start" → Click "Device manager" from menu.
- ② When "USB Serial Port (COM3)" is displayed in "Port (COM and LPT)", the COM port is assigned to No. 3.

Check the COM port number, and then close "Device Manager".

(4) Starting the console software (SWC-QTC101M)

- ① Start the console software (SWC-QTC101M).

Select "QTC1-4" in the Device selection.

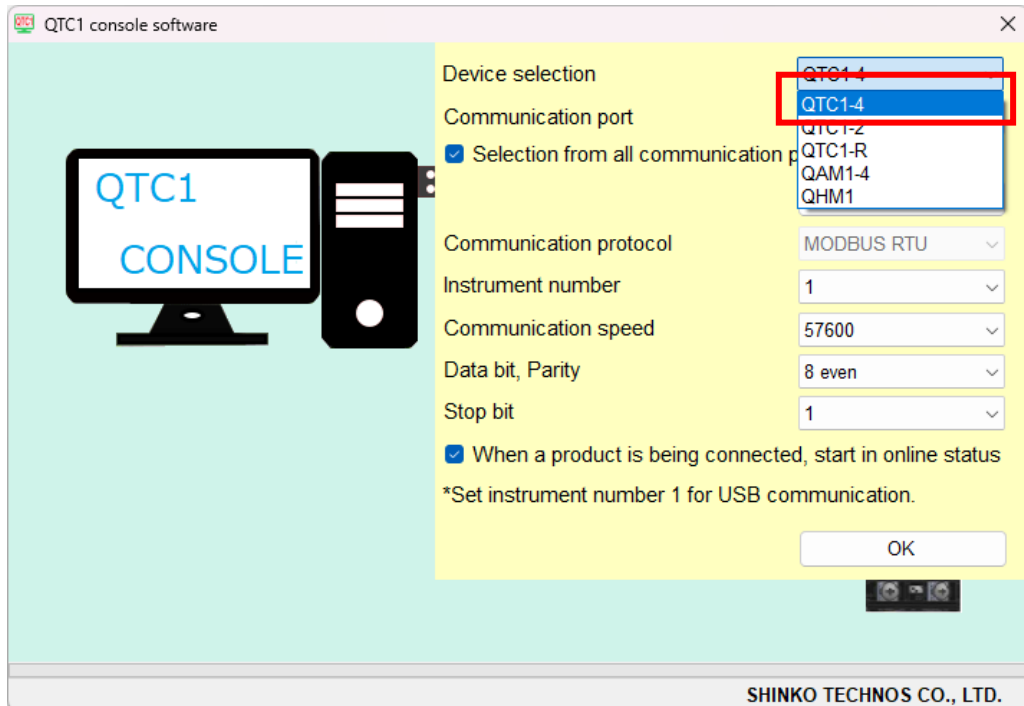

(Fig. 13.6.2-2)

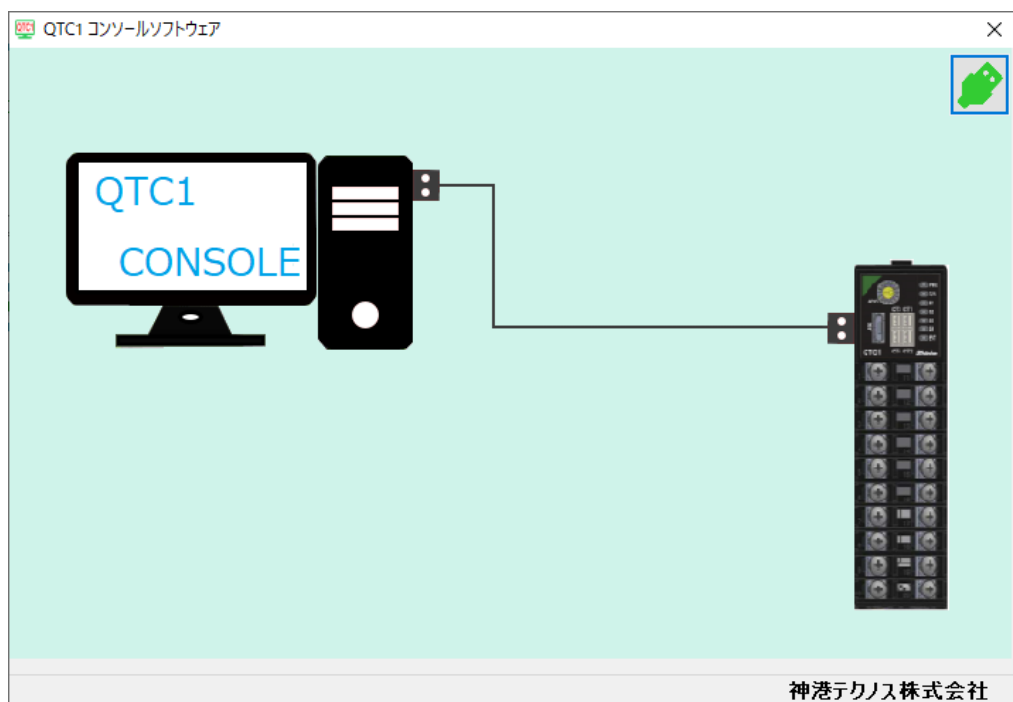

(Fig. 13.6.2-3)

- ② Click [User (U)] on the menu bar → [Communication conditions (C)].
Display the communication condition setting screen.

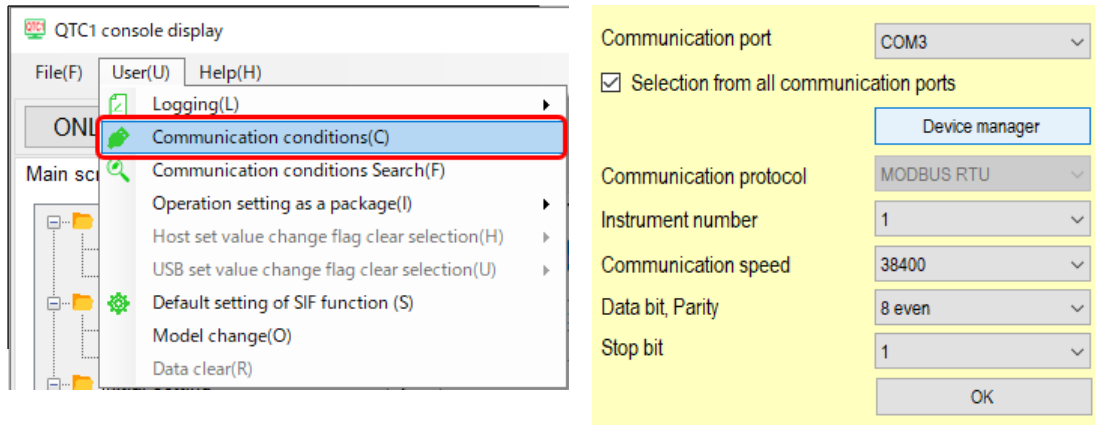

(Fig. 13.6.2-4)

*The model "QTC1-4" can also be selected from User (U) - Model change (o) in the menu bar.

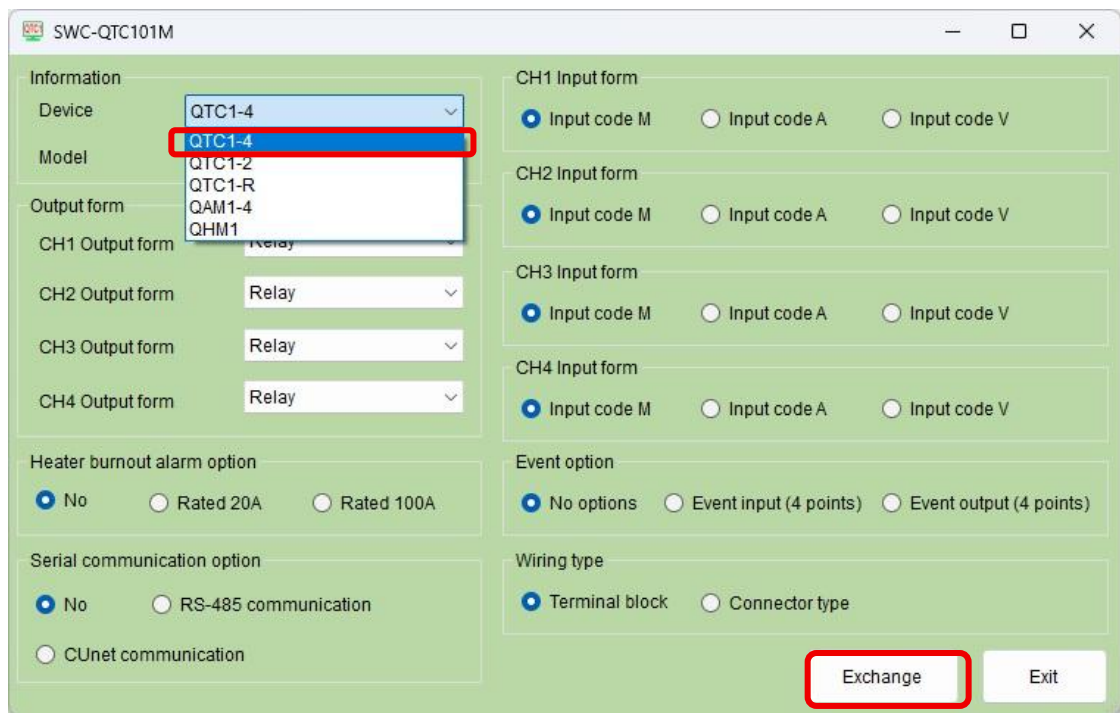

(Fig. 13.6.2-5)

- ③ Set the communication condition as shown below.

Setup Items	Setting Value
Communication port	Select the COM port number confirmed in ② of (3).
Communication protocol	MODBUS RTU

- ④ Click [OK]

- ⑤ Click “Default setting of SIF function(S)” from “User(U)” of menu bar.
Display “Default setting of SIF function” screen.

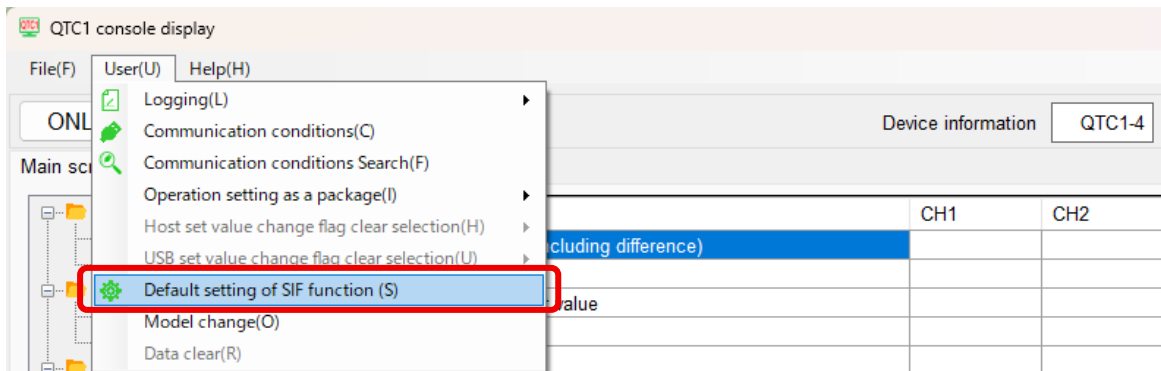

(Fig. 13.6.2-6)

- ⑥ Select “Module 1” and click “System” tab.

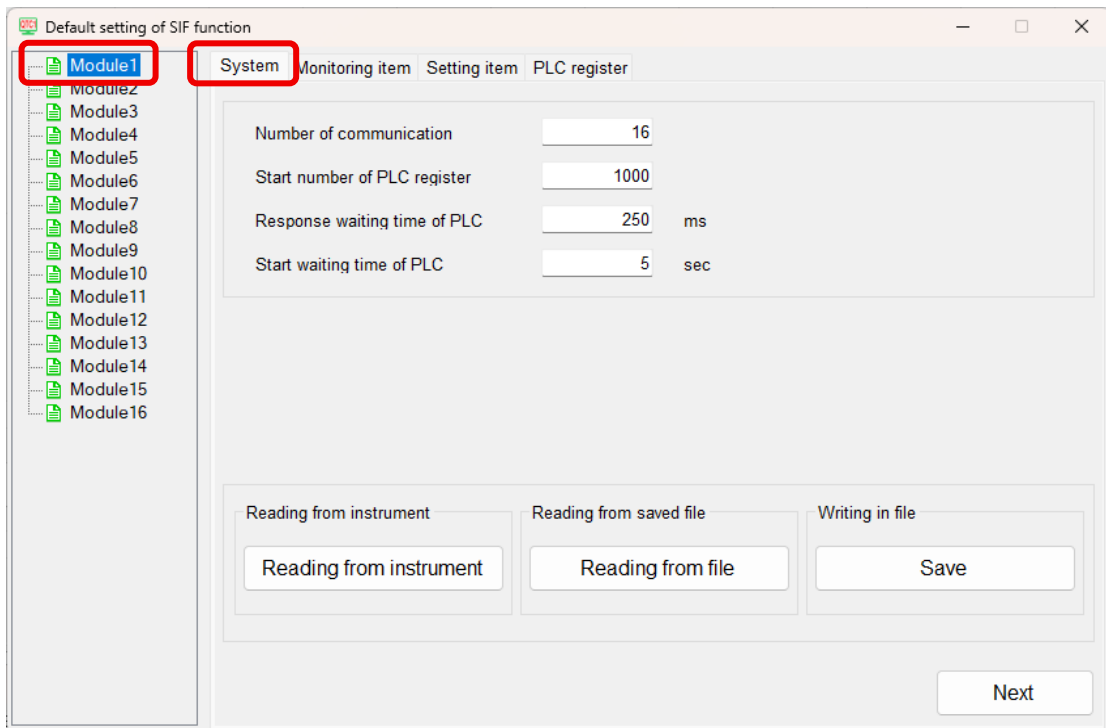

(Fig. 13.6.2-7)

The specifications are ready.

13.6.3 Specification Setting

Specification setting of control module QTC1-4P

Set the specifications of the control module QTC1-4P with reference to the SIF function initial setting items.

SIF function initial setting items

MODBUS address		Name	Settings • Selection range	Initial value	Remarks (*)
HEX	DEC				
020A	522	Communication management module number setting	1 to 16 modules	1	1
0384	900	PLC register start number	0 to 65535	1000	0
0385	901	PLC response wait time	100 to 3000 ms	200	1
0386	902	PLC communication start wait time	1 to 255 seconds	5	1
0387	903	Reservation (Not used)		0	0
0388	904	Reservation (Not used)		0	0
0389	905	Monitor item 1	Refer to Monitor item 1 (P.13-17)	31	0
038A	906	Monitor item 2	Refer to Monitor item 2 (P.13-18)	0	0
038B	907	Monitor item 3	Refer to Monitor item 3 (P.13-18)	0	0
038C	908	Reservation (Not used)		0	0
038D	909	Reservation (Not used)		0	0
038E	910	Setting item 1	Refer to Setting item 1 (P.13-19)	57827	0
038F	911	Setting item 2	Refer to Setting item 2 (P.13-19)	2721	0
0390	912	Setting item 3	Refer to Setting item 3 (P.13-20)	0	0
0391	913	Setting item 4	Refer to Setting item 4 (P.13-20)	0	0
0392	914	Setting item 5	Refer to Setting item 5 (P.13-21)	0	0
0393	915	Setting item 6	Refer to Setting item 6 (P.13-21)	0	0
0394	916	Setting item 7	Refer to Setting item 7 (P.13-22)	0	0

(*) 0: The value set in each module is a valid item.

1: The value set in the control module QTC1-4P is a valid item.

(1) Communication management module number setting

Set the number of modules managed by the master module.

Set the number of modules including the master module.

(2) PLC register start number

Set the start number of the register used in PLC communication. It is fixed to the D register. Please set in the range of 0 to 65535.

For A compatible 1C frame AnA/AnU, set within the range of 0 to 8191.

A maximum of 170 registers are used per control module. [System area: 10 registers, Monitor item: 80 registers (20 × 4ch), Setting item: 80 registers (20 × 4ch)]

When using multiple control modules, be careful not to duplicate them.

(3) PLC response wait time

Set the retransmission interval time when there is no response from the PLC.

Please set in the range of 100 to 3000 ms.

(4) PLC communication start wait time

Set the time from when the control module QTC1-4P power is turned on until communication is started to the PLC.

Please set in the range of 1 to 255 seconds.

(5) Monitor item 1 to 3

Click [Monitor item] tab or [Next] button.

Displays the Monitor item screen.

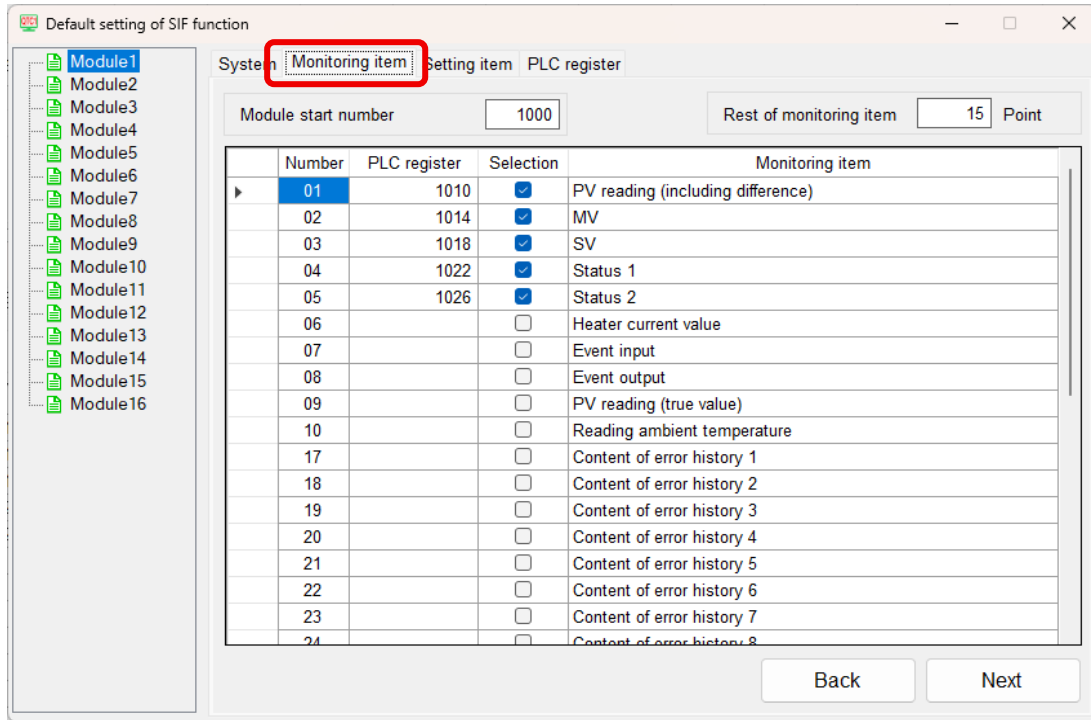

(Fig. 13.6.3-1)

Select any of Monitor item 1 to 3. The maximum number of valid item selections is 20. The excess is invalid for all channels in the control module.

Monitor item 1 (Initial value: 31)

Bit	No.	Selection	Description
0	01	1	PV reading (including difference)
1	02	1	MV reading
2	03	1	SV reading
3	04	1	Status flag 1 reading
4	05	1	Status flag 2 reading
5	06	0	Heater current value reading
6	07	0	Event input reading
7	08	0	Event output reading
8	09	0	PV reading (true value)
9	10	0	Ambient temperature reading
10	11	0	Not used
11	12	0	Not used
12	13	0	Not used
13	14	0	Not used
14	15	0	Not used
15	16	0	Not used

Monitor item 2 (Initial value: 0)

Bit	No.	Selection	Description
0	17	0	Alarm history 1 Error No.
1	18	0	Alarm history 2 Error No.
2	19	0	Alarm history 3 Error No.
3	20	0	Alarm history 4 Error No.
4	21	0	Alarm history 5 Error No.
5	22	0	Alarm history 6 Error No.
6	23	0	Alarm history 7 Error No.
7	24	0	Alarm history 8 Error No.
8	25	0	Alarm history 9 Error No.
9	26	0	Alarm history 10 Error No.
10	27	0	Alarm history 1 Total energizing time
11	28	0	Alarm history 2 Total energizing time
12	29	0	Alarm history 3 Total energizing time
13	30	0	Alarm history 4 Total energizing time
14	31	0	Alarm history 5 Total energizing time
15	32	0	Alarm history 6 Total energizing time

Monitor item 3 (Initial value: 0)

Bit	No.	Selection	Description
0	33	0	Alarm history 7 Total energizing time
1	34	0	Alarm history 8 Total energizing time
2	35	0	Alarm history 9 Total energizing time
3	36	0	Alarm history 10 Total energizing time
4	37	0	Contact switching total number of times (High)
5	38	0	Contact switching total number of times (Low)
6	39	0	Total energizing time (High, Low)
7	40	0	Heater accumulated energizing time (High)
8	41	0	Heater accumulated energizing time (Low)
9	42	0	Not used
10	43	0	Not used
11	44	0	Not used
12	45	0	Not used
13	46	0	Not used
14	47	0	Not used
15	48	0	Not used

(6) Setting item 1 to 7

Click [Setting item] tab or [Next] button.

Displays the Setting item screen.

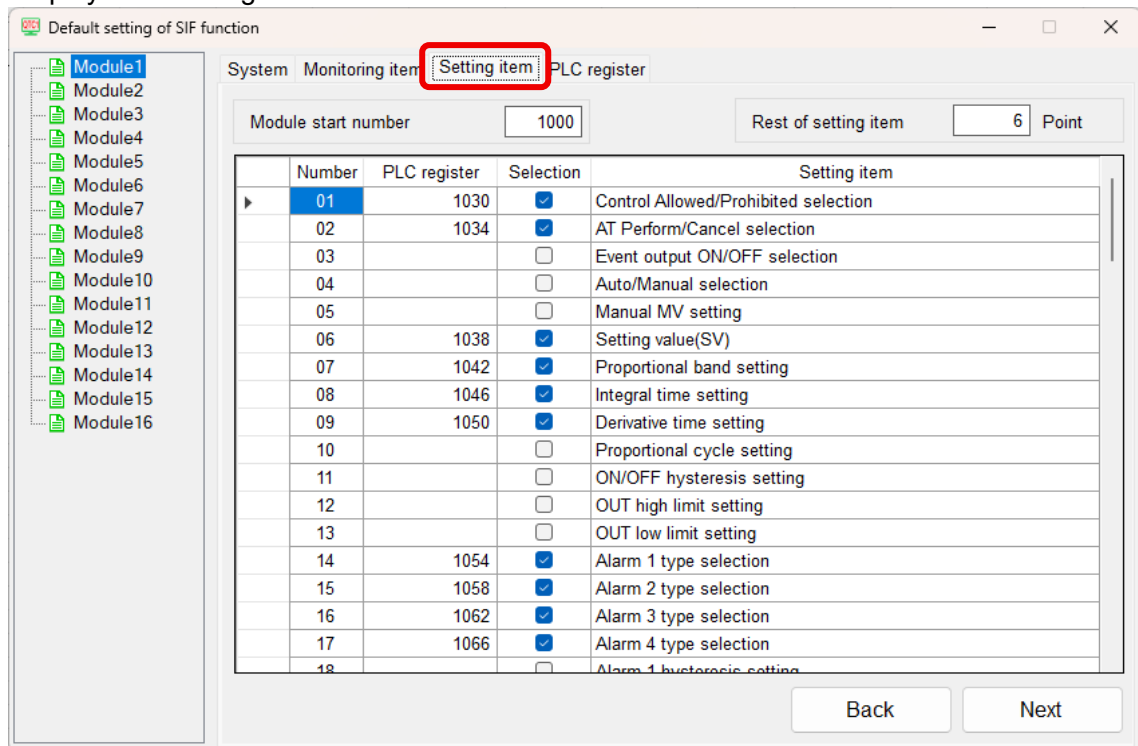

(Fig. 13.6.3-2)

Select any of Setting item 1 to 7. The maximum number of valid item selections is 20.

The excess is invalid for all channels in the control module.

Setting item 1 (Initial value: 57827)

Bit	Setting request item number	Selection	Description
0	1	1	Control Allowed/Prohibited selection
1	2	1	AT Perform/Cancel selection
2	3	0	Event output ON/OFF selection
3	4	0	Auto/Manual control selection
4	5	0	Manual MV setting
5	6	1	SV setting
6	7	1	Proportional band setting
7	8	1	Integral time setting
8	9	1	Derivative time setting
9	10	0	Proportional cycle setting
10	11	0	ON/OFF hysteresis setting
11	12	0	Output high limit setting
12	13	0	Output low limit setting
13	14	1	Alarm 1 action selection
14	15	1	Alarm 2 action selection
15	16	1	Alarm 3 action selection

Setting item 2 (Initial value: 2721)

Bit	Setting request item number	Selection	Description
0	17	1	Alarm 4 action selection
1	18	0	Alarm 1 hysteresis setting
2	19	0	Alarm 2 hysteresis setting
3	20	0	Alarm 3 hysteresis setting
4	21	0	Alarm 4 hysteresis setting
5	22	1	Alarm 1 value setting
6	23	0	Alarm 1 high limit value setting
7	24	1	Alarm 2 value setting
8	25	0	Alarm 2 high limit value setting
9	26	1	Alarm 3 value setting
10	27	0	Alarm 3 high limit value setting
11	28	1	Alarm 4 value setting
12	29	0	Alarm 4 high limit value setting
13	30	0	Heater burnout alarm setting
14	31	0	Loop break alarm band setting
15	32	0	Loop break alarm time setting

Setting item 3 (Initial value: 0)

Bit	Setting request item number	Selection	Description
0	33	0	Sensor correction factor setting
1	34	0	Sensor correction setting
2	35	0	PV filter time constant setting
3	36	0	SV rise rate setting
4	37	0	SV fall rate setting
5	38	0	MV bias setting
6	39	0	Not used
7	40	0	Not used
8	41	0	Not used
9	42	0	Not used
10	43	0	Not used
11	44	0	Not used
12	45	0	Not used
13	46	0	Not used
14	47	0	Not used
15	48	0	Not used

Setting item 4 (Initial value: 0)

Bit	Setting request item number	Selection	Description
0	49	0	Input type selection
1	50	0	Temperature unit selection
2	51	0	Scaling high limit setting
3	52	0	Scaling low limit setting
4	53	0	Input sampling selection
5	54	0	Direct/Reverse action selection
6	55	0	AT action mode selection
7	56	0	AT bias setting
8	57	0	ATgain setting
9	58	0	Alarm 1 value 0 Enabled/Disabled selection
10	59	0	Alarm 2 value 0 Enabled/Disabled selection
11	60	0	Alarm 3 value 0 Enabled/Disabled selection
12	61	0	Alarm 4 value 0 Enabled/Disabled selection
13	62	0	Event output allocation selection
14	63	0	Event input allocation selection
15	64	0	CH Enabled/Disabled selection

Setting item 5 (Initial value: 0)

Bit	Setting request item number	Selection	Description
0	65	0	Number of moving average setting
1	66	0	Input math function selection
2	67	0	Input difference selection
3	68	0	Input difference setting
4	69	0	Control action selection
5	70	0	Proportional gain 2 DOF coefficient (α) setting
6	71	0	Integral 2 DOF coefficient (β) setting
7	72	0	Derivative 2 DOF coefficient (γ , Cd) setting
8	73	0	Desired value proportional coefficient (Cp) setting
9	74	0	Gap width setting
10	75	0	Gap coefficient setting
11	76	0	Output minimum ON/OFF time setting
12	77	0	Integral/Derivative decimal point position selection
13	78	0	Power-on restore action selection
14	79	0	Not used
15	80	0	Not used

Setting item 6 (Initial value: 0)

Bit	Setting request item number	Selection	Description
0	81	0	Control function selection
1	82	0	Cooling P-band setting
2	83	0	Cooling Integral time setting
3	84	0	Cooling Derivative time setting
4	85	0	Cooling proportional cycle setting
5	86	0	Cooling ON/OFF hysteresis setting
6	87	0	Overlap/Dead band setting
7	88	0	Cooling output high limit setting
8	89	0	Cooling output low limit setting
9	90	0	Cooling action mode selection
10	91	0	Slave scale high limit setting
11	92	0	Slave scale low limit setting
12	93	0	Output bias setting
13	94	0	Output gain setting
14	95	0	Output channel selection
15	96	0	Output rate-of-change setting

Setting item 7 (Initial value: 0)

Bit	Setting request item number	Selection	Description
0	97	0	Communication response delay time setting
1	98	0	Extension function selection
2	99	0	Total current setting
3	100	0	Current value setting
4	101	0	OUT ON delay setting
5	102	0	Auto balance control Interlock/Single selection
6	103	0	Auto balance control Master/Slave selection
7	104	0	Auto balance control Enabled/Disabled selection
8	105	0	Auto balance control start output setting
9	106	0	Auto balance control cancel area setting
10	107	0	Number of communication management module setting
11	108	0	Non-volatile IC memory save selection
12	109	0	Not used
13	110	0	Not used
14	111	0	Not used
15	112	0	Not used

(7) Control module power OFF → ON

Turn the control module power off and then on. The set value becomes effective.

This completes the specification setting.

If multiple control modules are connected, connect the USB communication cable to the next control module.

Click User (U) - Model change (o) in the menu bar.

This will display the Change Model screen.

Select "QAM1-4" and click the [Exchange] button.

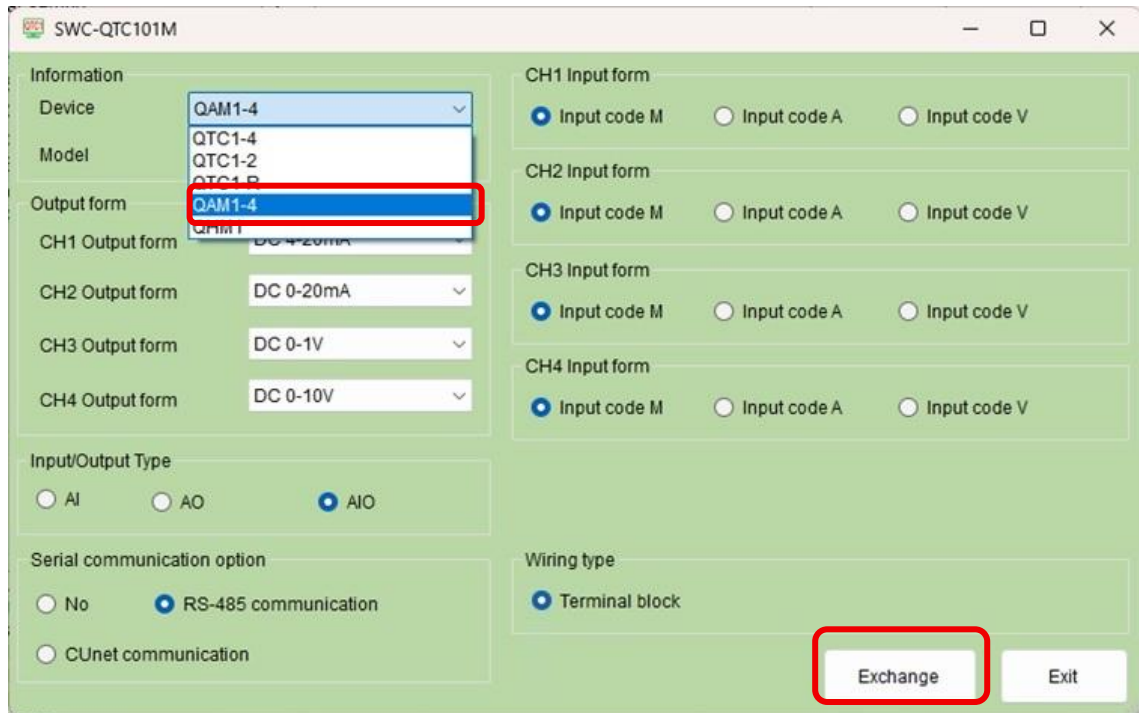

(Fig. 13.6.3-3)

Click "Default setting of SIF function(S)" from "User(U)" of menu bar.

Display "Default setting of SIF function" screen.

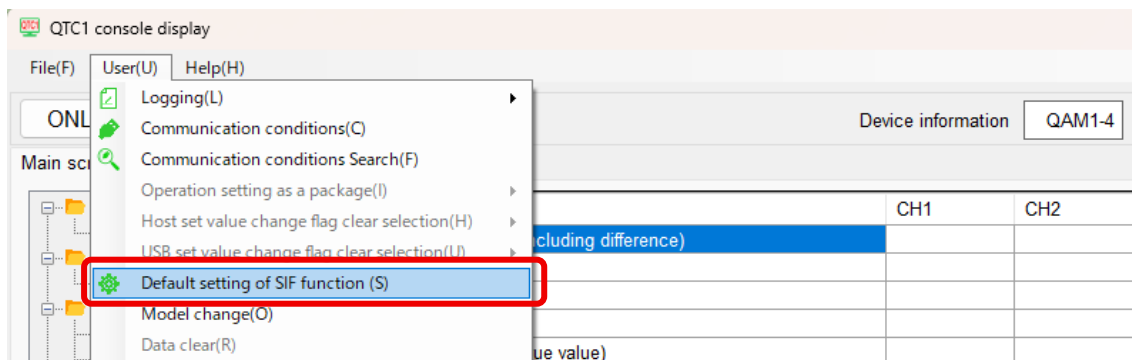

(Fig. 13.6.3-4)

Select the connected module number (Example: Module 2) and click the [System] tab.

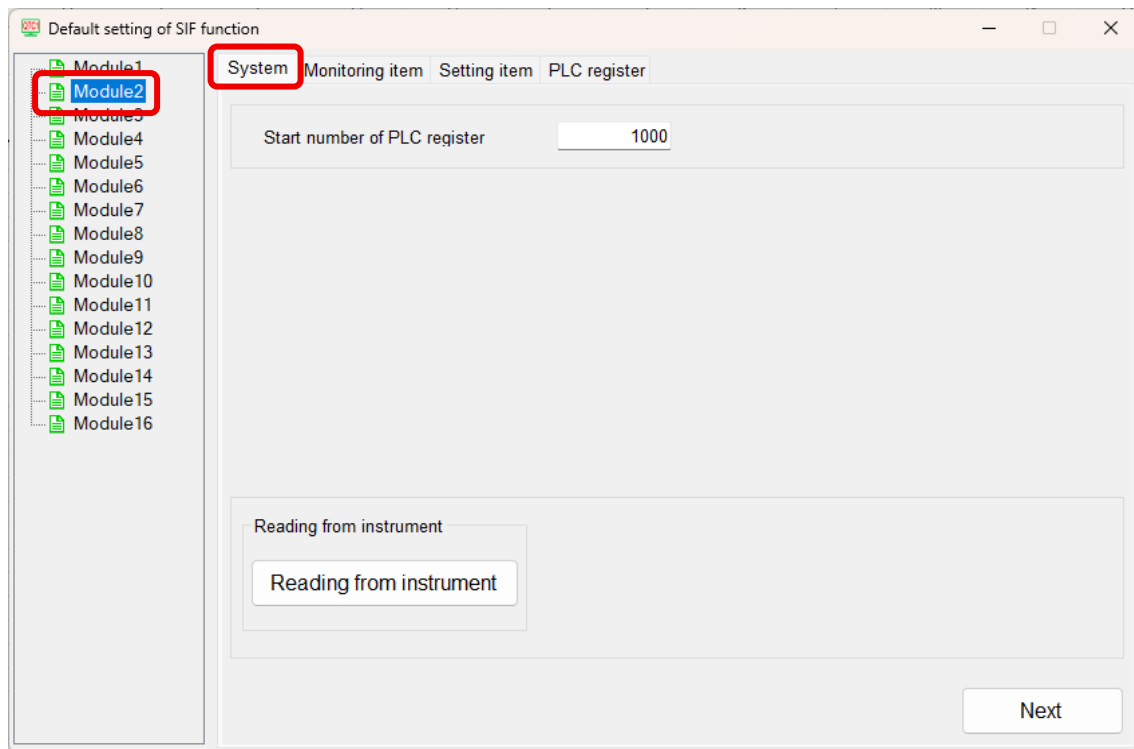

(Fig. 13.6.3-5)

Specification setting of analog I/O module QAM1-40

Set the specifications of analog I/O module QAM1-40 referring to the SIF function initial setting items.

SIF function initial setting items

MODBUS address		Name	Settings • Selection range	Initial value	Remarks (*)
HEX	DEC				
020A	522	Communication management module number setting	1 to 16 modules	1	1
0384	900	PLC register start number	0 to 65535	1100	0
0385	901	PLC response wait time	100 to 3000 ms	200	1
0386	902	PLC communication start wait time	1 to 255 seconds	5	1
0387	903	Reservation (Not used)		0	0
0388	904	Reservation (Not used)		0	0
0389	905	Monitor item 1	Refer to Monitor item 1 (P.13-24)	27	0
038A	906	Monitor item 2	Refer to Monitor item 2 (P.13-25)	0	0
038B	907	Monitor item 3	Refer to Monitor item 3 (P.13-25)	0	0
038C	908	Reservation (Not used)		0	0
038D	909	Reservation (Not used)		0	0
038E	910	Setting item 1	Refer to Setting item 1 (P.13-26)	16	0
038F	911	Setting item 2	Refer to Setting item 2 (P.13-26)	0	0
0390	912	Setting item 3	Refer to Setting item 3 (P.13-27)	0	0
0391	913	Setting item 4	Refer to Setting item 4 (P.13-27)	0	0
0392	914	Setting item 5	Refer to Setting item 5 (P.13-28)	0	0
0393	915	Setting item 6	Refer to Setting item 6 (P.13-28)	0	0
0394	916	Setting item 7	Refer to Setting item 7 (P.13-29)	0	0

(*) 0: The value set in each module is a valid item.

1: The value set in the control module QTC1-4P is a valid item.

(1) Communication management module number setting

Set the number of modules managed by the master module.

Set the number of modules including the master module.

(2) PLC register start number

Set the start number of the register used in PLC communication. It is fixed to the D register.

Please set in the range of 0 to 65535.

For A compatible 1C frame AnA/AnU, set within the range of 0 to 8191.

A maximum of 170 registers are used per control module. [System area: 10 registers,

Monitor item: 80 registers (20 × 4ch), Setting item: 80 registers (20 × 4ch)]

When using multiple control modules, be careful not to duplicate them.

(3) PLC response wait time

Set the retransmission interval time when there is no response from the PLC.

Please set in the range of 100 to 3000 ms.

(4) PLC communication start wait time

Set the time from when the control module QTC1-4P power is turned on until communication is started to the PLC.

Please set in the range of 1 to 255 seconds.

(5) Monitor item 1 to 3

Click [Monitor item] tab or [Next] button.

Displays the Monitor item screen.

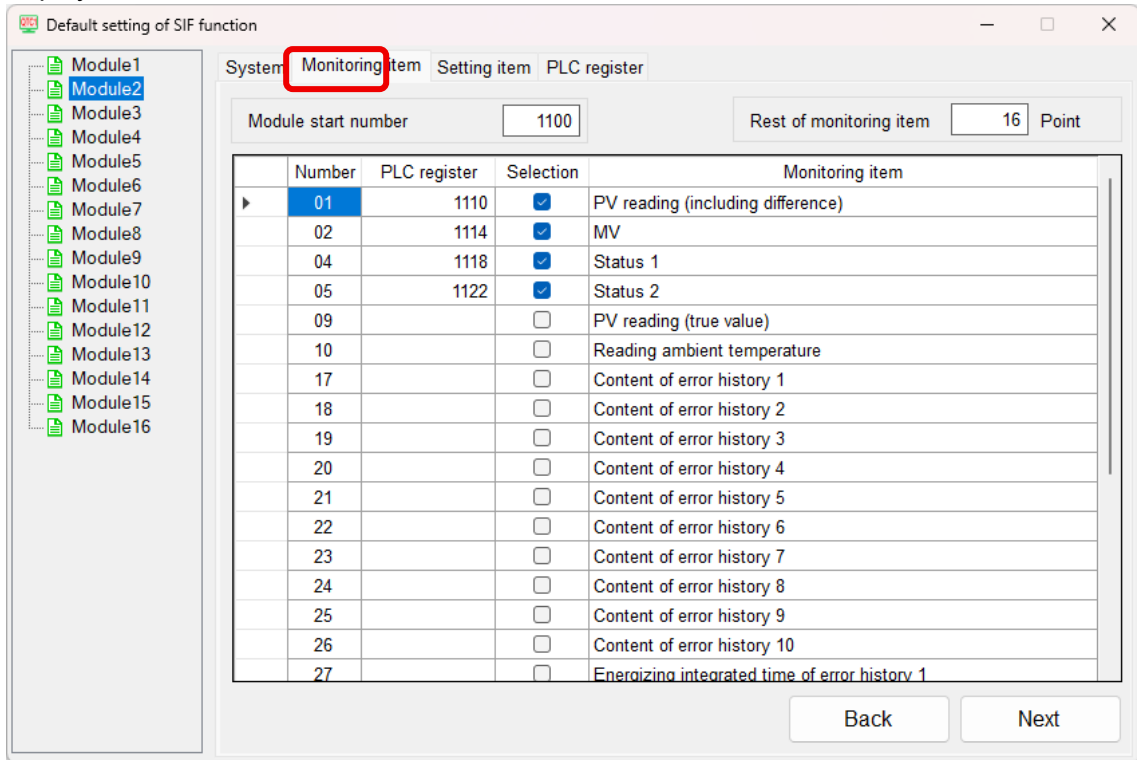

(Fig. 13.6.3-6)

Select any of Monitor item 1 to 3. The maximum number of valid item selections is 20.

The excess is invalid for all channels in the control module.

Monitor item 1 (Initial value: 27)

Bit	No.	Selection	Description
0	01	1	PV reading (including difference)
1	02	1	Output volume reading
2	03	0	Not used
3	04	1	Status flag 1 reading
4	05	1	Status flag 2 reading
5	06	0	Not used
6	07	0	Not used
7	08	0	Not used
8	09	0	PV reading (true value)
9	10	0	Ambient temperature reading
10	11	0	Not used
11	12	0	Not used
12	13	0	Not used
13	14	0	Not used
14	15	0	Not used
15	16	0	Not used

Monitor item 2 (Initial value: 0)

Bit	No.	Selection	Description
0	17	0	Alarm history 1 Error No.
1	18	0	Alarm history 2 Error No.
2	19	0	Alarm history 3 Error No.
3	20	0	Alarm history 4 Error No.
4	21	0	Alarm history 5 Error No.
5	22	0	Alarm history 6 Error No.
6	23	0	Alarm history 7 Error No.
7	24	0	Alarm history 8 Error No.
8	25	0	Alarm history 9 Error No.
9	26	0	Alarm history 10 Error No.
10	27	0	Alarm history 1 Total energizing time
11	28	0	Alarm history 2 Total energizing time
12	29	0	Alarm history 3 Total energizing time
13	30	0	Alarm history 4 Total energizing time
14	31	0	Alarm history 5 Total energizing time
15	32	0	Alarm history 6 Total energizing time

Monitor item 3 (Initial value: 0)

Bit	No.	Selection	Description
0	33	0	Alarm history 7 Total energizing time
1	34	0	Alarm history 8 Total energizing time
2	35	0	Alarm history 9 Total energizing time
3	36	0	Alarm history 10 Total energizing time
4	37	0	Not used
5	38	0	Not used
6	39	0	Total energizing time (High, Low)
7	40	0	Not used
8	41	0	Not used
9	42	0	Not used
10	43	0	Not used
11	44	0	Not used
12	45	0	Not used
13	46	0	Not used
14	47	0	Not used
15	48	0	Not used

(6) Setting item 1 to 7

Click [Setting item] tab or [Next] button.

Displays the Setting item screen.

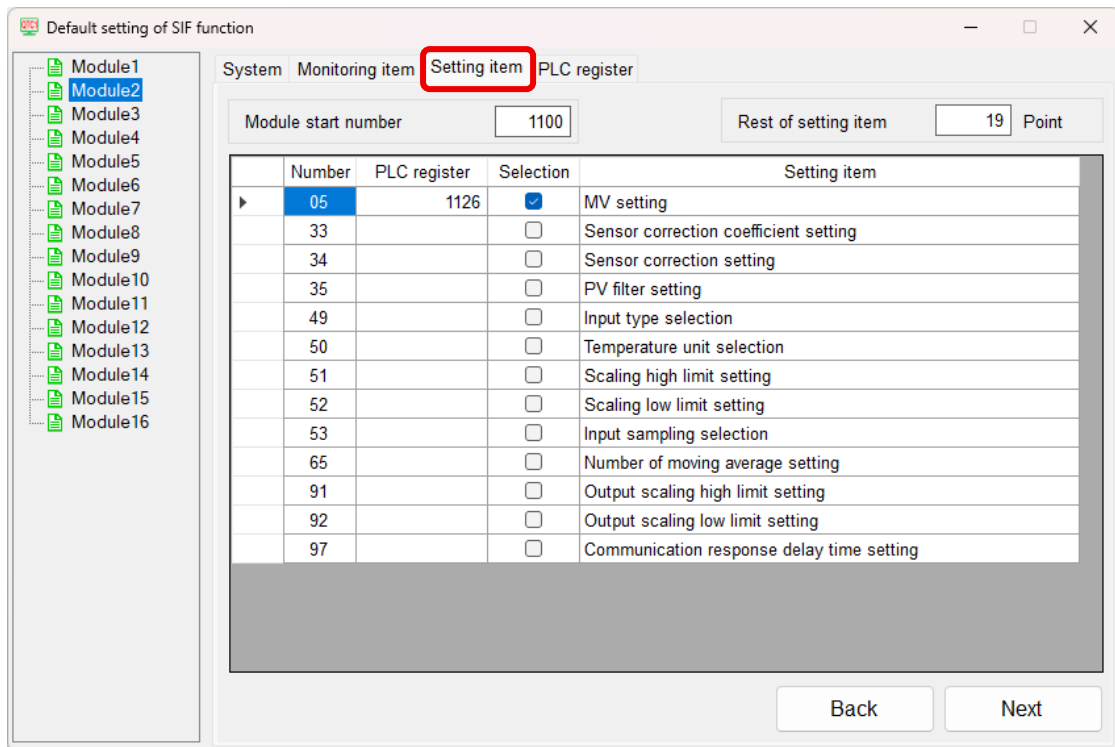

(Fig. 13.6.3-7)

Select any of Setting item 1 to 7. The maximum number of valid item selections is 20. The excess is invalid for all channels in the control module.

Setting item 1 (Initial value: 16)

Bit	Setting request item number	Selection	Description
0	1	0	Not used
1	2	0	Not used
2	3	0	Not used
3	4	0	Not used
4	5	0	Output volume setting
5	6	0	Not used
6	7	0	Not used
7	8	0	Not used
8	9	0	Not used
9	10	0	Not used
10	11	0	Not used
11	12	0	Not used
12	13	0	Not used
13	14	0	Not used
14	15	0	Not used
15	16	0	Not used

Setting item 2 (Initial value: 0)

Bit	Setting request item number	Selection	Description
0	17	0	Not used
1	18	0	Not used
2	19	0	Not used
3	20	0	Not used
4	21	0	Not used
5	22	0	Not used
6	23	0	Not used
7	24	0	Not used
8	25	0	Not used
9	26	0	Not used
10	27	0	Not used
11	28	0	Not used
12	29	0	Not used
13	30	0	Not used
14	31	0	Not used
15	32	0	Not used

Setting item 3 (Initial value: 0)

Bit	Setting request item number	Selection	Description
0	33	0	Sensor correction factor setting
1	34	0	Sensor correction setting
2	35	0	PV filter time constant setting
3	36	0	Not used
4	37	0	Not used
5	38	0	Not used
6	39	0	Not used
7	40	0	Not used
8	41	0	Not used
9	42	0	Not used
10	43	0	Not used
11	44	0	Not used
12	45	0	Not used
13	46	0	Not used
14	47	0	Not used
15	48	0	Not used

Setting item 4 (Initial value: 0)

Bit	Setting request item number	Selection	Description
0	49	0	Input type selection
1	50	0	Temperature unit selection
2	51	0	Input scaling high limit setting
3	52	0	Input scaling low limit setting
4	53	0	Input sampling selection
5	54	0	Not used
6	55	0	Not used
7	56	0	Not used
8	57	0	Not used
9	58	0	Not used
10	59	0	Not used
11	60	0	Not used
12	61	0	Not used
13	62	0	Not used
14	63	0	Not used
15	64	0	Not used

Setting item 5 (Initial value: 0)

Bit	Setting request item number	Selection	Description
0	65	0	Number of moving average setting
1	66	0	Not used
2	67	0	Not used
3	68	0	Not used
4	69	0	Not used
5	70	0	Not used
6	71	0	Not used
7	72	0	Not used
8	73	0	Not used
9	74	0	Not used
10	75	0	Not used
11	76	0	Not used
12	77	0	Not used
13	78	0	Not used
14	79	0	Not used
15	80	0	Not used

Setting item 6 (Initial value: 0)

Bit	Setting request item number	Selection	Description
0	81	0	Not used
1	82	0	Not used
2	83	0	Not used
3	84	0	Not used
4	85	0	Not used
5	86	0	Not used
6	87	0	Not used
7	88	0	Not used
8	89	0	Not used
9	90	0	Not used
10	91	0	Output scaling high limit setting
11	92	0	Output scaling low limit setting
12	93	0	Not used
13	94	0	Not used
14	95	0	Not used
15	96	0	Not used

Setting item 7 (Initial value: 0)

Bit	Setting request item number	Selection	Description
0	97	0	Communication response delay time setting
1	98	0	Not used
2	99	0	Not used
3	100	0	Not used
4	101	0	Not used
5	102	0	Not used
6	103	0	Not used
7	104	0	Not used
8	105	0	Not used
9	106	0	Not used
10	107	0	Not used
11	108	0	Not used
12	109	0	Not used
13	110	0	Not used
14	111	0	Not used
15	112	0	Not used

(7) Control module power OFF → ON

Turn the control module power off and then on. The set value becomes effective.

This completes the specification setting for the analog I/O module QAM1-40.

13.7 Operation

The following explains how to connect two modules to the PLC.

Connection example of PLC and QTC1-4P, QAM1-40

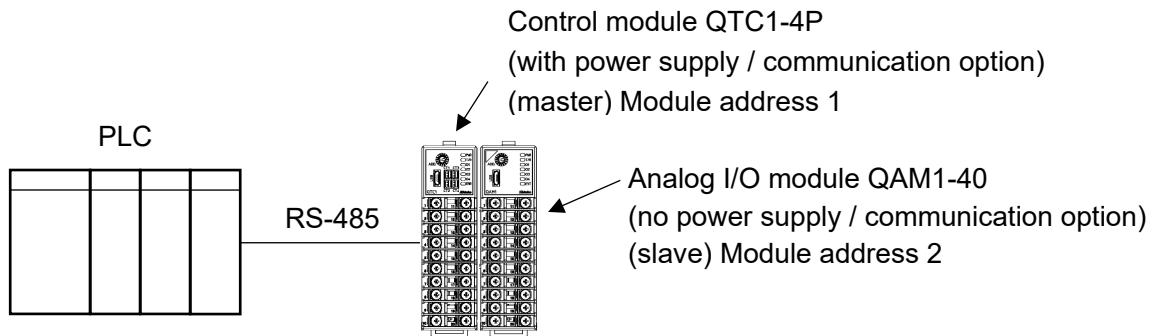

(Fig. 13.7-1)

13.7.1 Communication Procedure

- (1) The control module QTC1-4P becomes the master and collects the valid monitor items and setting items of the analog I/O module QAM1-40 (slave).
- (2) After the PLC communication start waiting time has elapsed, the control module QTC1-4P periodically writes the item selected in the monitor items to the PLC register.

Also, the item selected from the setting items is read from the PLC register in response to a setting request.

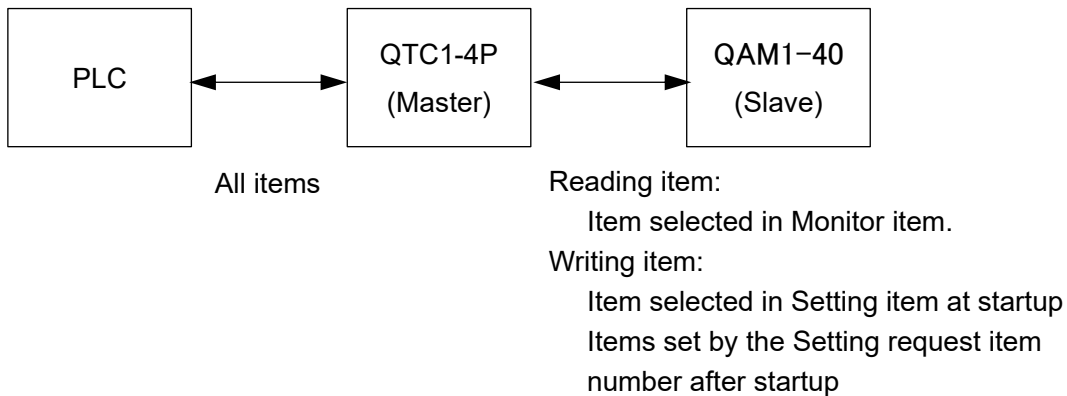

(Fig. 13.7.1-1)

13.7.2 PLC Communication Data Map

Shown below is the PLC communication data map when the initial setting example for PLC communication is set.

Example of initial setting for PLC communication

MODBUS address		Name	QTC1-4P (Master) setting	QAM1-40 (Slave) setting
HEX	DEC			
0384	900	PLC register start number	1000	1100
0385	901	PLC response wait time	200	200
0386	902	PLC communication start wait time	5	5
0387	903	Reservation (Not used)	0	0
0388	904	Reservation (Not used)	0	0
0389	905	Monitor item 1	31	27
038A	906	Monitor item 2	0	0
038B	907	Monitor item 3	0	0
038C	908	Reservation (Not used)	0	0
038D	909	Reservation (Not used)	0	0
038E	910	Setting item 1	57827	16
038F	911	Setting item 2	2721	0
0390	912	Setting item 3	0	0
0391	913	Setting item 4	0	0
0392	914	Setting item 5	0	0
0393	915	Setting item 6	0	0
0394	916	Setting item 7	0	0

PLC data register layout

	QTC1-4P (Master)	QAM1-40 (Slave)
Information between QTC1-4 and PLC (system data)	1000 to 1009	1100 to 1109
Monitor item	1010 to 1029	1110 to 1125
Setting item	1030 to 1085	1126 to 1137

Details of information (system data) between control module QTC1-4 and PLC

Control module QTC1-4 (Master)

Data	PLC data register	Attribute	Description
Communication status	1000	RO	0: QTC1-4P collecting data 1: QTC1-4P completes data collection (Startup: Initial setting value of each slave)
QTC1-4 - PLC Normal communication monitor	1001	RO	Increment counter Repeat 0 to 65535 → 0 to 65535
QTC1-4 Error code	1002	RO	B0: PLC register R/W error 0: Normal 1: Error B1: QTC1-4P communication error 0: Normal 1: Error B2: QTC1-4P Negative acknowledgement when setting 0: Normal 1: Error (It will be cleared when B0 of 1006 is cleared.)
Setting request monitor	1003	RO	B0: Setting (Reflect and set to B0 of 1006.) B1: Monitoring (Reflect and set until B1 of 1006 is cleared.)
Reservation	1004	RO	
Setting request item number	1005	R/W	0: All items selected in setting items 1 to 7 1 to 112: Items selected in setting items 1 to 7 (1 data) Only the data (1 data) of the selected item will be read or written. However, because communication with the PLC is a batch process, all the selected items are read or written.
Setting request command (*)	1006	R/W	B0: Setting request (PLC → QTC1-4P) QTC1-4P requests to read the setting item data from the PLC register. B1: Monitor request (QTC1-4P → PLC) QTC1-4P requests to write the setting item data to the PLC register. After the setting request or monitor request is completed, QTC1-4P clears each bit.
Reservation	1007	R/W	
Reservation	1008	R/W	
Reservation	1009	R/W	

(*): If the setting request and the monitor request are set at the same time, processing is performed in the following procedure: ① setting request (QTC1-4P reads PLC register data), ② monitor request (writing data to PLC register).

If the setting request is set during the monitor request, the monitor request is discarded and the monitoring request is made again after the setting request.

Analog I/O module QAM1-40 (Slave)

Data	PLC data register	Attribute	Description
Communication status	1100	RO	0: QTC1-4P collecting data of QAM1-40 1: QTC1-4P completes data collection of QAM1-40 (Startup: Initial setting value of each slave)
QTC1-4 - PLC Normal communication monitor	1101	RO	Increment counter Repeat 0 to 65535 → 0 to 65535
QTC1-4 Error code	1102	RO	B0: PLC register R/W error 0: Normal 1: Error B1: Communication error between QTC1-4P and QAM1-40 0: Normal 1: Error B2: Negative acknowledgement when setting QTC1-4P to QAM1-40 (It will be cleared when B0 of 1006 is cleared.) 0: Normal 1: Error
Setting request monitor	1103	RO	B0: Setting (Reflect and set to B0 of 1006.) B1: Monitoring (Reflect and set until B1 of 1006 is cleared.)
Reservation	1104	RO	
Setting request item number	1105	R/W	0: All items selected in setting items 1 to 7 1 to 112: Items selected in setting items 1 to 7 (1 data) Only the data (1 data) of the selected item will be read or written. However, because communication with the PLC is a batch process, all the selected items are read or written.
Setting request command (*)	1106	R/W	B0: Setting request (PLC → QTC1-4P) QTC1-4P requests to read the setting item data from the PLC register. B1: Monitor request (QTC1-4P → PLC) QTC1-4P requests to write the setting item data to the PLC register. After the setting request or monitor request is completed, QTC1-4P clears each bit.
Reservation	1107	R/W	
Reservation	1108	R/W	
Reservation	1109	R/W	

(*): If the setting request and the monitor request are set at the same time, processing is performed in the following procedure: ① setting request (QTC1-4P reads PLC register data), ② monitor request (writing data to PLC register).

If the setting request is set during the monitor request, the monitor request is discarded and the monitoring request is made again after the setting request.

Details of monitor item and setting item between control module QTC1-4 and PLC

Control module QTC1-4P (Master)

Data item	Channel	PLC data register	Attribute	Data
PV reading (Including difference)	CH1 CH2 CH3 CH4	1010 1011 1012 1013	RO	The value of "14.2.1 Control range (P.14-6)". Supports input math function (difference input, addition input) and input difference detection function.
MV reading	CH1 CH2 CH3 CH4	1014 1015 1016 1017	RO	Output low limit to Output high limit
SV reading	CH1 CH2 CH3 CH4	1018 1019 1020 1021	RO	Scaling low limit to Scaling high limit
Status flag 1 reading	CH1 CH2 CH3 CH4	1022 1023 1024 1025	RO	B0: Control Allowed/Prohibited 0: Prohibited 1: Allowed B1: AT Perform/Cancel 0: Cancel 1: Perform B2: Auto/Manual control 0: Automatic 1: Manual B3: Control output 0: OFF 1: ON B4: Input error (Overscale) 0: Normal 1: Error B5: Input error (Underscale) 0: Normal 1: Error B6: Alarm 1 output 0: OFF 1: ON B7: Alarm 2 output 0: OFF 1: ON B8: Alarm 3 output 0: OFF 1: ON B9: Alarm 4 output 0: OFF 1: ON B10: Loop brake alarm output 0: OFF 1: ON B11: Heater burnout alarm output 0: OFF 1: ON B12: Input difference 0: Within range 1: Out of range B13: Not used (indefinite) B14: Power supply identification 0: 24 V DC 1: USB bus power B15: Non-volatile IC memory error 0: Normal 1: Error

Data item	Channel	PLC data register	Attribute	Data
Status flag 2 reading	CH1 CH2 CH3 CH4	1026 1027 1028 1029	RO	B0: Auto balance control 0: None 1: During auto balance control B1 to B3: Not used (indefinite) B4: Cold junction error 0: Normal 1: Error B5: Sensor error 0: Normal 1: Error B6: ADC error 0: Normal 1: Error B7: Host setting value change flag 0: Without flag 1: With flag B8: USB setting value change flag 0: Without flag 1: With flag B9 to B11: Not used (indefinite) B12 to B14: Peak power suppress function output status flag 0: Output enabled. 1: Output standby 2: Output enabled in next cycle 3: Output enabled (MV=0 %) B15: Not used (indefinite)
Control Allowed/Prohibited selection	CH1 CH2 CH3 CH4	1030 1031 1032 1033	R/W	0: Prohibited 1: Allowed
AT Perform/Cancel selection	CH1 CH2 CH3 CH4	1034 1035 1036 1037	R/W	0: AT Cancel 1: AT Perform
SV setting	CH1 CH2 CH3 CH4	1038 1039 1040 1041	R/W	Scaling low limit to Scaling high limit
Proportional band setting	CH1 CH2 CH3 CH4	1042 1043 1044 1045	R/W	1 to Input span °C (°F) or 0.1 to Input span °C (°F) when direct current and DC voltage input 0.10 to 100.00%
Integration time setting	CH1 CH2 CH3 CH4	1046 1047 1048 1049	R/W	0 to 3600 seconds or 0.0 to 2000.0 seconds when "2: Slow-PID control" is selected in control action selection. 1 to 3600 seconds or 0.1 to 2000.0 seconds
Derivative time setting	CH1 CH2 CH3 CH4	1050 1051 1052 1053	R/W	0 to 3600 seconds or 0.0 to 2000.0 seconds

Data item	Channel	PLC data register	Attribute	Data
Alarm 1 action selection	CH1	1054	R/W	0: No action 1: High limit alarm 2: Lowh limit alarm 3: High/Low limits alarm 4: High/Low limit s range 5: Process High alarm 6: Process low alarm 7: High limit with standby 8: Low limit with standby 9: High/Low limits alarm with individually 10: High/Low limits alarm individually 11: High/Low limit s range alarm individually 12: High/Low limits alarm with standby individually Refer to "Alarm 1 to 4 value setting range table".
	CH2	1055		
	CH3	1056		
	CH4	1057		
Alarm 2 action selection	CH1	1058	R/W	
	CH2	1059		
	CH3	1060		
	CH4	1061		
Alarm 3 action selection	CH1	1062	R/W	
	CH2	1063		
	CH3	1064		
	CH4	1065		
Alarm 4 action selection	CH1	1066	R/W	
	CH2	1067		
	CH3	1068		
	CH4	1069		
Alarm 1 value setting	CH1	1070	R/W	
	CH2	1071		
	CH3	1072		
	CH4	1073		
Alarm 2 value setting	CH1	1074	R/W	
	CH2	1075		
	CH3	1076		
	CH4	1077		
Alarm 3 value setting	CH1	1078	R/W	
	CH2	1079		
	CH3	1080		
	CH4	1081		
Alarm 4 value setting	CH1	1082	R/W	
	CH2	1083		
	CH3	1084		
	CH4	1085		

Alarm 1 to 4 value setting range table

Alarm type	Setting range
No action	
High limit alarm	-(Input span) to Input span (*1)
Lowh limit alarm	-(Input span) to Input span (*1)
High/Low limits alarm	0 to Input span (*1)
High/Low limit s range	0 to Input span (*1)
Process High alarm	Input range lower limit to Input range high limit (*2)
Process low alarm	Input range lower limit to Input range high limit (*2)
High limit with standby	-(Input span) to Input span (*1)
Low limit with standby	-(Input span) to Input span (*1)
High/Low limits alarm with	0 to Input span (*1)
High/Low limits alarm individually	0 to Input span (*1)
High/Low limit s range alarm individually	0 to Input span (*1)
High/Low limits alarm with standby individually	0 to Input span (*1)

(*1): When direct current input and DC voltage input, the input span is the scaling width.

(*2): When direct current input and DC voltage input, the Input range lower limit is the scaling lower limit, and the Input range high limit is the scaling high limit.

Analog I/O module QAM1-40 (Slave)

Data item	Channel	PLC data register	Attribute	Data
PV reading (Including difference)	CH1 CH2 CH3 CH4	1110 1111 1112 1113	RO	Reading value (decimal point omitted)
Output volume reading	CH1 CH2 CH3 CH4	1114 1115 1116 1117	RO	Reading value (decimal point omitted) 0.00 to 100.00 %
Status flag 1 reading	CH1 CH2 CH3 CH4	1118 1119 1120 1121	RO	B0 to B2: Not used (indefinite) B3: Output volume is out of setting range 0: Normal 1: Error ON B4: Input error (Overscale) 0: Normal 1: Error B5: Input Error (Underscale) 0: Normal 1: Error B6 to B13: Not used (indefinite) B14: Power supply identification 0: 24 V DC 1: USB bus power B15: Non-volatile IC memory error 0: Normal 1: Error
Status flag 2 reading	CH1 CH2 CH3 CH4	1122 1123 1124 1125	RO	B0 to B3: Not used (indefinite) B4: Cold junction error 0: Normal 1: Error B5: Sensor error 0: Normal 1: Error B6: ADC error 0: Normal 1: Error B7: Host setting value change flag 0: Without flag 1: With flag B8: USB setting value change flag 0: Without flag 1: With flag B9 to B15: Not used (indefinite)
Output volume setting	CH1 CH2 CH3 CH4	1126 1127 1128 1129	R/W	Output scaling low limit to output scaling high limit
Sensor correction factor setting	CH1 CH2 CH3 CH4	1130 1131 1132 1133	R/W	0.000 to 10.000

Data item	Channel	PLC data register	Attribute	Data
Sensor correction setting	CH1	1134	R/W	-100.0 to 100.0°C (-180.0 to 180.0°F) For direct current input and DC voltage input: -1000 to 1000
	CH2	1135		
	CH3	1136		
	CH4	1137		

13.7.3 Data Exchange between Control Module QTC1-4 and P-PLC

Data transfer between the control module QTC1-4P and PLC is performed by the setting request item number and setting request command.

(1) Setting request item number

Set whether to transfer the data of all items selected in setting item 1 to 7 selection or only the data (1 data) of the selected item.

0: Transfers the data of all items selected in setting item 1 to 7 selection.

1 to 112: Transfers only the data (1 data) of the item selected in setting item 1 to 7 selection.

(2) Setting request command

The setting request command includes setting request and monitor request.

B0: Setting request (PLC → QTC1-4P)

The control module QTC1-4P is a command to request to read the data of the setting item of the PLC register.

B1: Monitor request (QTC1-4P → PLC)

The control module QTC1-4P is a command to request to write the data of the setting item of the PLC register.

If setting request and monitor request are set at the same time, processing is performed in the order of setting request (QTC1-4P reads the data of the setting item in the PLC register) and then monitor request (writing the data of the setting item in the PLC register).

If a setting request is set during monitor request, the monitor request is discarded and the monitor request is made again after the setting request.



Caution

When setting data, first write all the setting item data to the PLC register.

Note that if you change the setting items of the analog I/O module QAM1-40 without writing all the setting item data, it may be overwritten with an undefined value and malfunction may occur.

Data setting procedure

When setting the output volume of the analog I/O module QAM1-40

- (1) Set 0 to the setting request item number
To write all the setting item data to the PLC register, set 0 to 1105 (setting request item number).
- (2) Set B1 (monitor request) of the setting request command
Set 1 (decimal number: 2) to B1 (monitor request) of 1106 (setting request command).
The control module QTC1-4P starts writing the setting item data to the PLC register.
- (3) Check B1 (monitor request) of the setting request command
When the writing of the setting item data to the PLC register is completed, B1 (monitor request) of 1106 (setting request command) is cleared.
- (4) Set data
Set output volume to 1126 to 1129 (output volume setting) of the PLC register.
- (5) Set 5 to the setting request item number
To read the output volume setting data of the PLC register, set 5 to 1105 (setting request item number).
- (6) Set B0 (setting request) of the setting request command
Set 0 (decimal number: 1) to B0 (monitor request) of 1106 (setting request command).
The control module QTC1-4P starts reading the setting item data of the PLC register.
- (7) Check B0 (monitor request) of the setting request command
When the reading of the setting item data to the PLC register is completed, B0 (monitor request) of 1106 (setting request command) is cleared.

14 CUnet Communication

CUnet communication writes the reading value from the module to the global memory (GM) specified by the station address (SA).

It reads the setting values from the master address (DOSA) and sets them to the module.

The setting value can also be changed by using the mail function of CUnet.

Configuration example of host computer (master board) and QAM1-4C

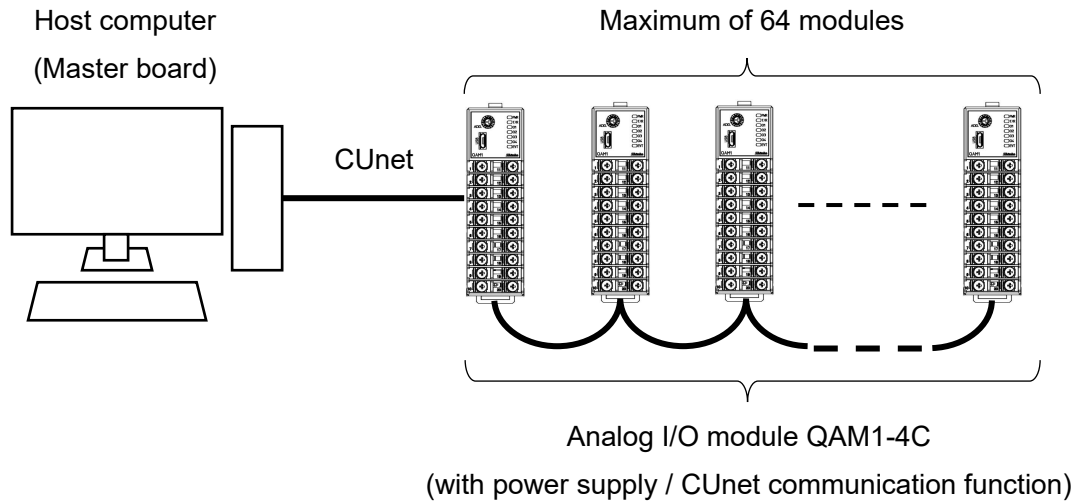

(Fig. 14-1)

14.1 Flow of Before Operation

The flow of operation when using CUNet communication is shown below.

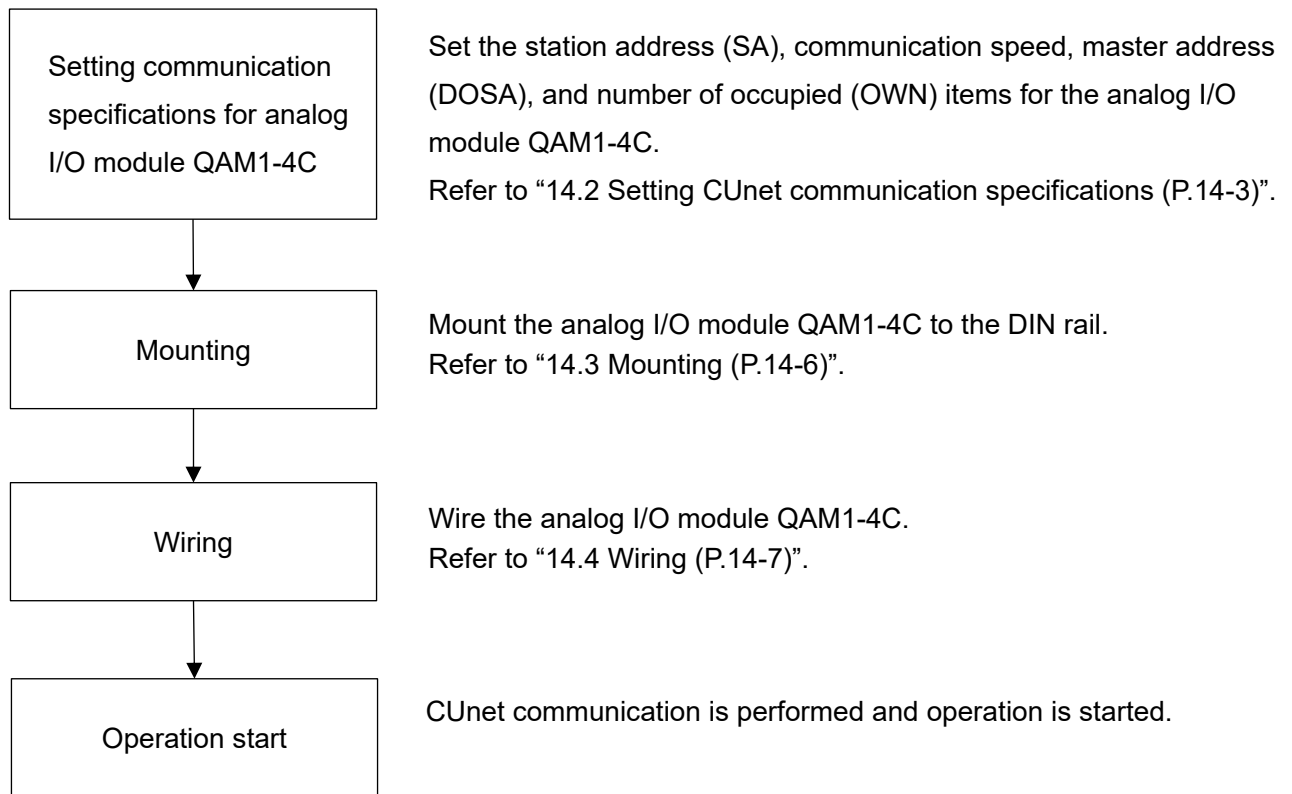

(Fig. 14.1-1)

14.2 Setting CUnet communication specifications

The CUnet communication specifications are set by the dip switches (SW10, SW11) on the base part.

(1) Case removal

- ① Push the release lever on the top of this instrument to unlock it.
- ② Remove the case.

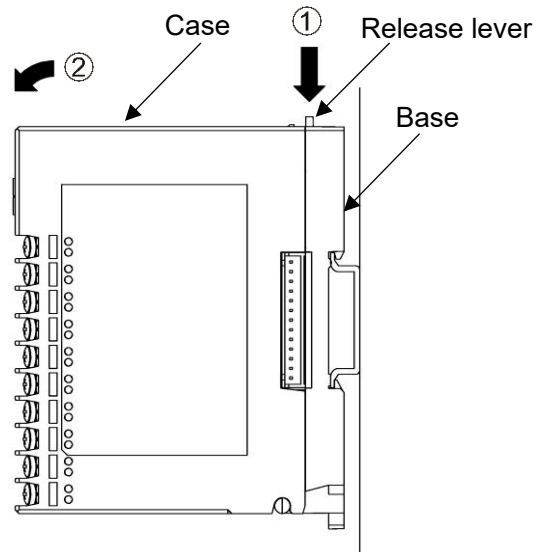

(Fig. 14.2-1)

(2) Station address (SA), communication speed setting (SW10)



Caution

Please set the station address (SA) so that there are no duplicate addresses.

The station address (SA) and communication speed are set by DIP switch (SW10).

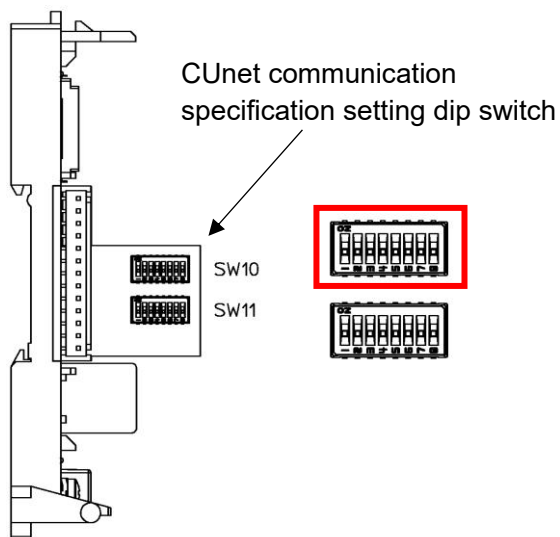

(Fig. 14.2-2)

Set the station address (SA) and communication speed.

The setting range of the station address (SA) is 00 to 63.

No.	Setting item	Status	Factory default
1	Station address setting	Bit0 ON: Enable, OFF: Disable	Disable
2		Bit1 ON: Enable, OFF: Disable	Disable
3		Bit2 ON: Enable, OFF: Disable	Disable
4		Bit3 ON: Enable, OFF: Disable	Disable
5		Bit4 ON: Enable, OFF: Disable	Disable
6		Bit5 ON: Enable, OFF: Disable	Disable
7	Communication speed setting	7: OFF 8: OFF 12 Mbps	12 Mbps
8		7: ON 8: OFF 6 Mbps	
		7: OFF 8: ON 3 Mbps	
		7: ON 8: ON Disable (12 Mbps)	

(3) Master address (DOSA) and number of occupied (OWN) items selection (SW11)

The master address (DOSA) and the number of occupied (OWN) items are set by DIP switch (SW11).

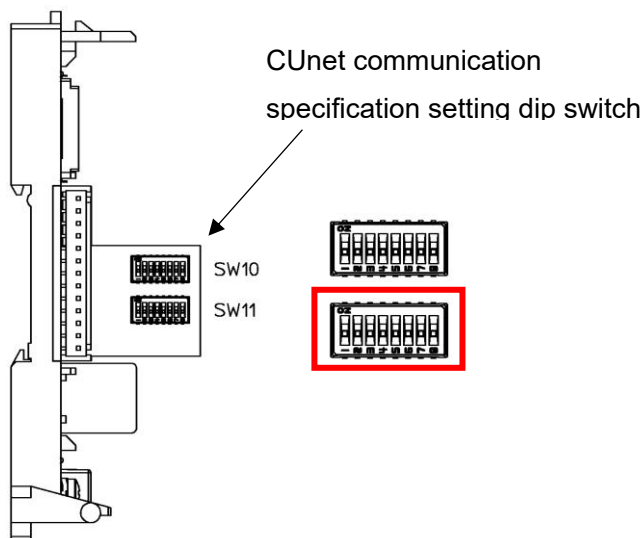

(Fig. 14.2-3)

Set the master address (DOSA) and the number of occupied (OWN) items.

Set which master global memory (GM) area data is output to the analog output terminal.

The setting range of the master address (DOSA) is 00 to 63.

No.	Setting item	Status	Factory default
1	Master address setting	Bit0 ON: Enable, OFF: Disable	Disable
2		Bit1 ON: Enable, OFF: Disable	Disable
3		Bit2 ON: Enable, OFF: Disable	Disable
4		Bit3 ON: Enable, OFF: Disable	Disable
5		Bit4 ON: Enable, OFF: Disable	Disable
6		Bit5 ON: Enable, OFF: Disable	Disable
7	Number of occupied (OWN) items selection(*)	7: OFF 8: OFF 1 item	1 item
8		7: ON 8: OFF 2 items	
		7: OFF 8: ON 3 items	
		7: ON 8: ON 4 items	

(*): The following items are allocated to global memory for each module.

Number of occupied (OWN) items	QAM1-4	
	DI item	DO item
1	PV: 03E8-03EB	Output: 0014-0017
2	Status 1: 03F4-03F7	
3	MV: 03EC-03EF	
4		

Shaded area is invalid because there is no allocation (no area is allocated in global memory)

(4) Case mounting

- ① Hook the case on the lower part ① of this instrument.
- ② Mount the case so that the lower part ① of this instrument is the fulcrum and covers the release lever. There is a clicking sound.

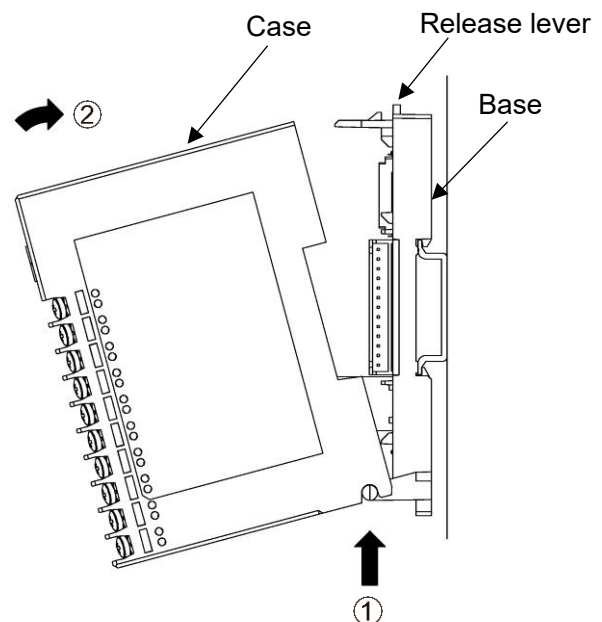

(Fig. 14.2-4)

14.3 Mounting

Mounting to the DIN rail

- ① Lower the lock lever of this instrument. (The lock lever of this instrument has a spring structure, but if lower it in the direction of the arrow until it stops, it will be locked in that position.)
- ② Hook the part ② of this instrument onto the top of the DIN rail.
- ③ Insert the lower part of this instrument with the part ② as a fulcrum.
- ④ Raise the lock lever of this instrument.

Make sure it is fixed to the DIN rail.

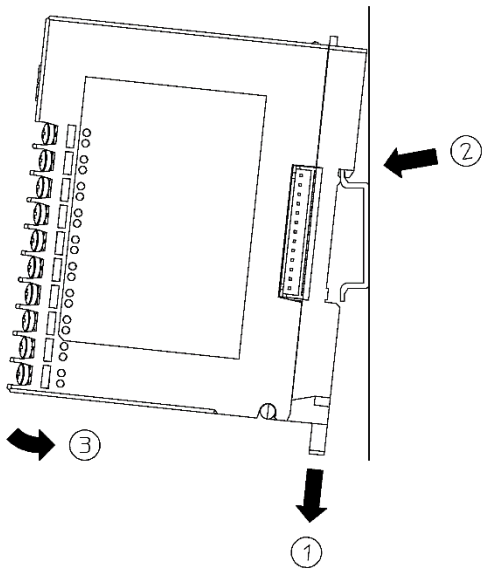

(Fig. 14.3-1)

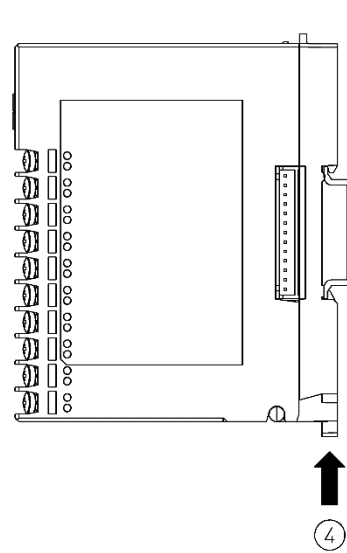

(Fig. 14.3-2)

Removal from the DIN rail

- ① Insert a flat blade screwdriver into the lock lever of this instrument and lower the lock lever until it stops.
- ② Remove this instrument from the DIN rail by lifting it from below.

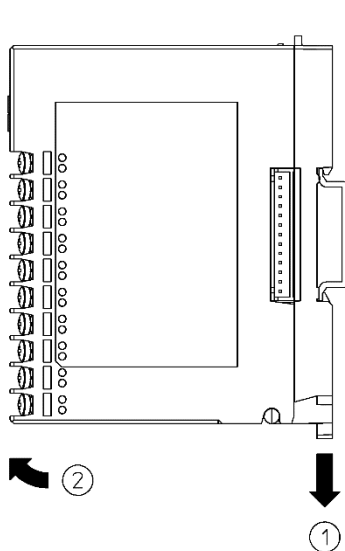

(Fig. 14.3-3)

14.4 Wiring

14.4.1 Wiring for Power Supply and Communication

The terminal block for power supply and communication is located on the base of this instrument. Wiring by the following procedure.

(1) Case removal

- ① Push the release lever on the top of this instrument to unlock it.
- ② Remove the case.

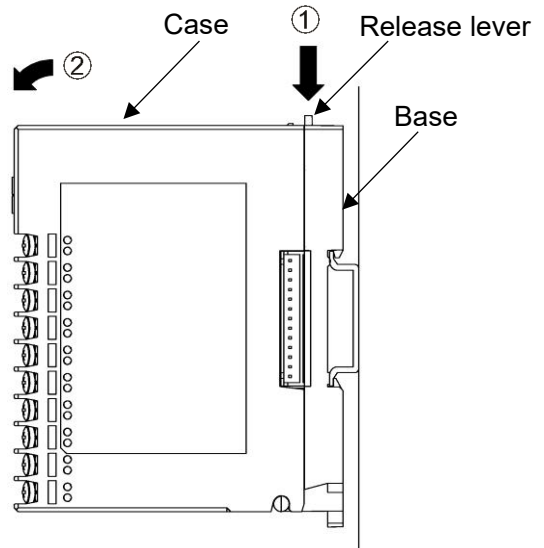

(Fig. 14.4.1-1)

(2) Wiring

CUnet communication

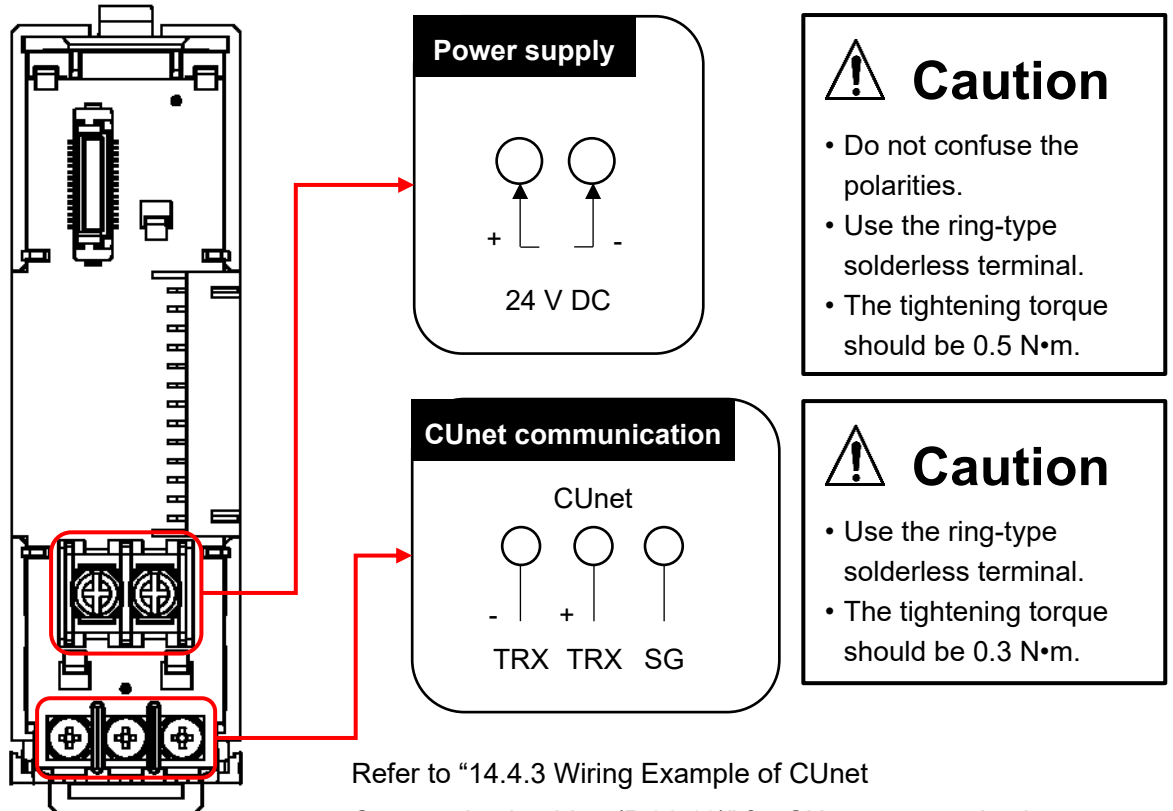

(Fig. 14.4.1-2)

(3) Case mounting

- ① Hook the case on the lower part ① of this instrument.
 - ② Mount the case so that the lower part ① of this instrument is the fulcrum and covers the release lever.
- There is a clicking sound.

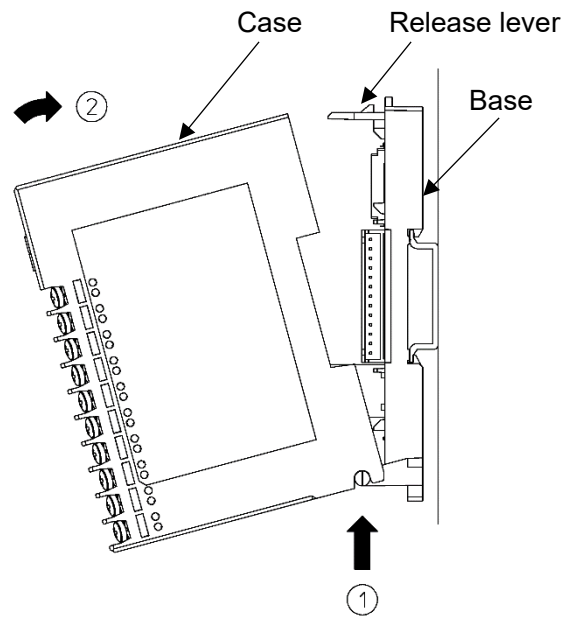

(Fig. 14.4.1-3)

⚠ Caution

- Please note that CH1, CH2 and CH3, CH4 have different terminal arrangements.
- The tightening torque should be 0.63 N•m.
- For DC current input (with an external receiving resistor), connect a receiving resistor [option 50 Ω (RES-S01-050)] between each input terminal (+ and -). For DC current input (built-in receiving resistor), a receiving resistor (50 Ω) is not required.

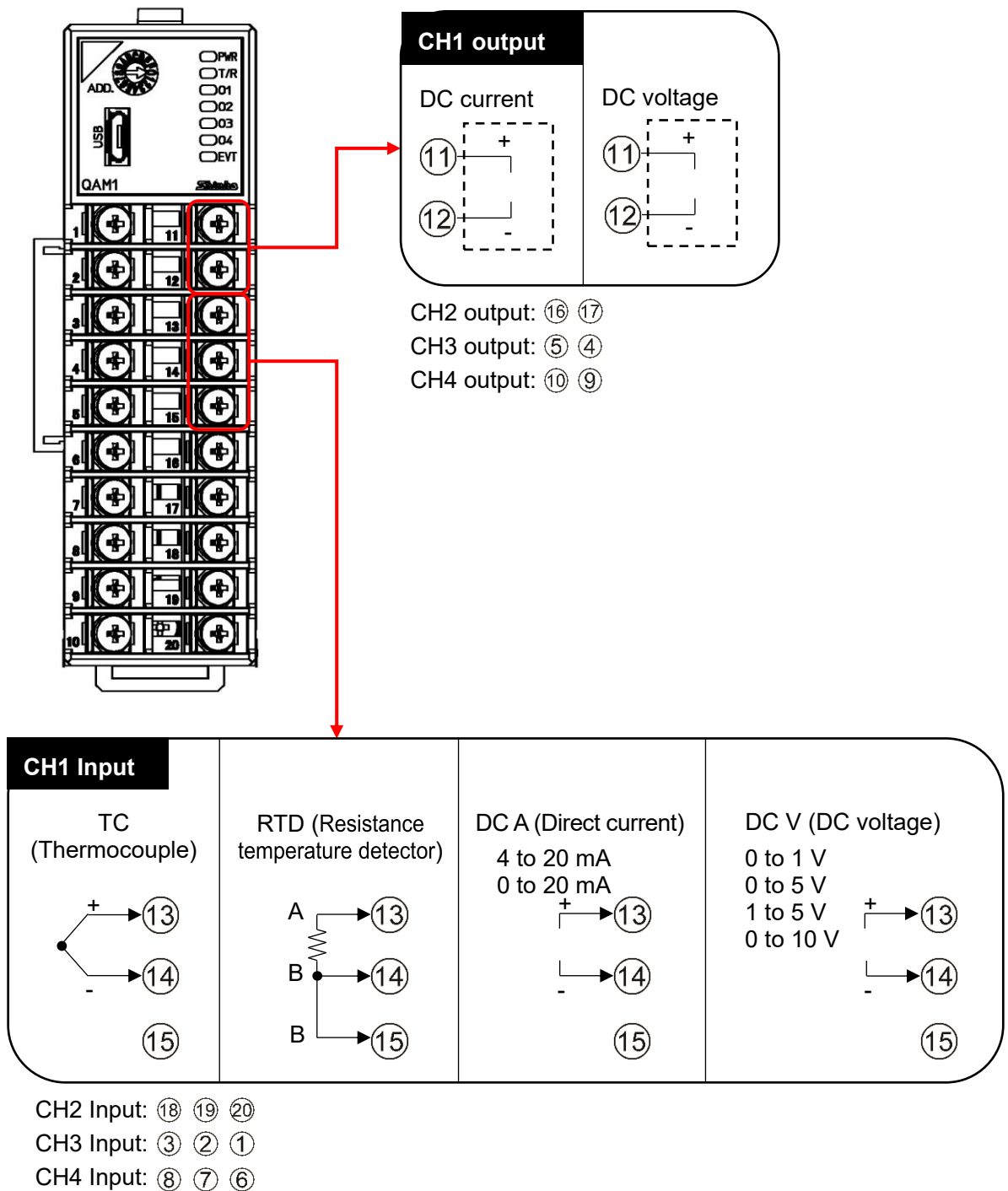

(Fig. 14.4.2-1)

14.4.3 Wiring Example of CUnet Communication Line

Connect the LAN cable between the upper system (master) and this instrument.

Recommended cable: LAN cable (straight cable) / Category 5 or higher shielded cable

Install a 100 Ω terminator [RES-S07-100 (optional)] on the last unit in the communication line.

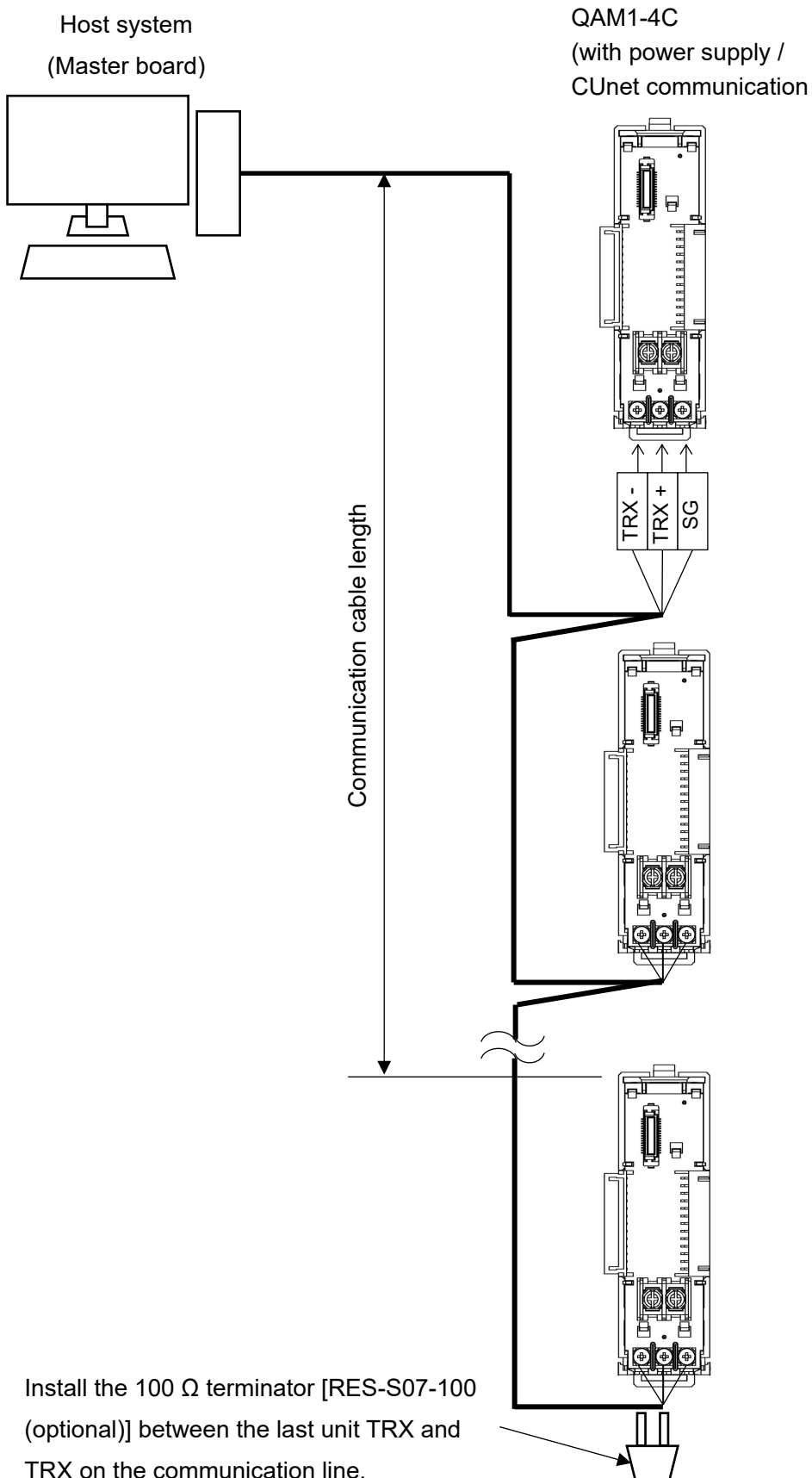

(Fig. 14.4.3-1)

The communication cable length is the total length of the communication cable from the upper system (master) to the last unit, and varies depending on the communication speed.

The communication cable length can be extended by inserting a dedicated HUB for CUnet.

Communication speed	Communication cable length		
	No HUB	HUB 1-deck	HUB 2-deck
12 Mbps	100 m	200 m	300 m
6 Mbps	200 m	400 m	600 m
3 Mbps	300 m	600 m	900 m

14.5 Global Memory (GM)

The memory space where memory data is shared is called global memory (GM).

The size of global memory (GM) is 512 bytes and is divided into 64 areas in 8-byte units corresponding to station addresses (SA).

The addresses in global memory (GM) correspond to station addresses (SA).

Station addresses (SA)	Global memory (GM)
00(0x00)	000H to 007H
01(0x01)	008H to 00FH
02(0x02)	010H to 017H
...	...
63(0x3F)	1F8H to 1FFH

The basic unit of the amount of data that can be written to global memory (GM) by one station is 8 bytes.

- Station 00 (0x00) writes data in the 000H to 007H area of the global memory (GM).
- Station 63 (0x3F) writes data in the 1F8H to 1FFH area of the global memory (GM).

All stations can read all areas of the global memory (GM).

- All units can read the 000H to 007H area of the global memory (GM) to obtain the data written by the 00 (0x00) station.
- All units can read the 1F8H to 1FFH area of the global memory (GM) to obtain the data written by the 63 (0x3F) station.

14.6 Software

CUnet master board and software are required for CUnet communication.

Using the software, the CUnet communication status and the input/output status of the unit can be controlled on the PC screen.

	Manufacturer	Model name
CUnet master board	StepTechnica Co., Ltd.	CU-43USB
Software	StepTechnica Co., Ltd.	ASSIST-CU

14.7 Global Memory (GM) Map

SA: Station Address

GM: Global Memory

DOSA: Data Output Station Address

(1) Number of occupied (OWN) items: 1 item

SA	GM+0	GM+2	GM+4	GM+6
16bit signed	PV (CH1)	PV (CH2)	PV (CH3)	PV (CH4)

DOSA	GM+0	GM+2	GM+4	GM+6
16bit signed	Output volume (CH1)	Output volume (CH2)	Output volume (CH3)	Output volume (CH4)

(2) Number of occupied (OWN) items: 2 items

SA	GM+0	GM+2	GM+4	GM+6	GM+8	GM+10	GM+12	GM+14
16bit signed	PV (CH1)	State 1 (CH1)	PV (CH2)	State 1 (CH2)	PV (CH3)	State 1 (CH3)	PV (CH4)	State 1 (CH4)

DOSA	GM+0	GM+2	GM+4	GM+6
16bit signed	Output volume (CH1)	Output volume (CH2)	Output volume (CH3)	Output volume (CH4)

DOSA is 1 item.

(3) Number of occupied (OWN) items: 3 items

SA	GM+0	GM+2	GM+4	GM+6	GM+8	GM+10	GM+12	GM+14
16bit signed	PV (CH1)	State 1 (CH1)	Output volume (CH1)	PV (CH2)	State 1 (CH2)	Output volume (CH2)	PV (CH3)	State 1 (CH3)
SA	GM+16	GM+18	GM+20	GM+22				
16bit signed	Output volume (CH3)	PV (CH4)	State 1 (CH4)	Output volume (CH4)				

DOSA	GM+0	GM+2	GM+4	GM+6
16bit signed	Output volume (CH1)	Output volume (CH2)	Output volume (CH3)	Output volume (CH4)

DOSA is 1 item.

(4) Number of occupied (OWN) items: 4 items

Same as 3 items.

When setting by CUnet communication, please set within the range of the module.

The data out of the setting range will be invalid.

For items not covered by global memory (GM), set them in the console software of each module or via e-mail communication.

14.8 Attached Function

Automatic recognition function of connection modules

At power-on, the configuration of connected modules is checked and the data of modules whose connection is recognized is expanded in global memory (GM).

15 Action Explanation

15.1 Standard Function

15.1.1 Input Scaling Function

This function is valid for DC voltage input and DC current input.

Set the input range (0 to 100 %) within the input scaling low limit to input scaling high limit.

The response is PV in the range of -1 to 110 %. However, if the -1 to 110 % value exceeds the -32768 to 32767 range, the response will be the value limited by -32768 or 32767.

If the input scaling high limit and input scaling low limit are set to the same value, the value will be that of the input scaling low limit.

For output-only type, PV is always 0.

15.1.2 Output Scaling Function

Set the range of output amount (0 to 100 %) in the range from the low limit of output scaling to the high limit of output scaling.

If an output amount outside this range is set, it becomes invalid and the previous output amount is retained.

If the output scaling high limit and output scaling low limit are set to the same value, the output will be 0%.

For the input-only type, the output is turned off.

15.1.3 Sensor Correction Factor

Set the slope of the sensor input value.

The sensor correction factor setting is calculated by the following formula.

Sensor correction factor setting = $(Y' - X') / (Y - X)$

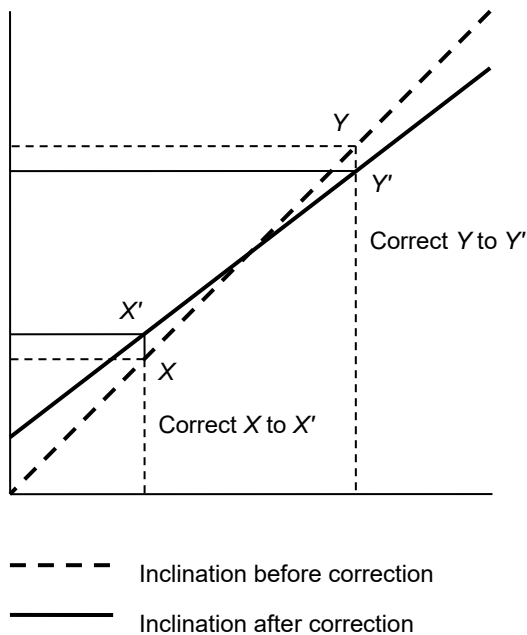

(Fig. 15.1.3-1)

15.1.4 Sensor Correction

If the temperature at the control location and the temperature at the sensor location are different, PV is corrected.

However, it is valid within the input rated range regardless of the sensor correction value.

PV after input correction is expressed by the following formula.

PV after input correction =

$$\text{Current PV} \times \text{Sensor correction factor setting value} + (\text{Sensor correction setting value})$$

15.2 Attached Function

15.2.1 Warm-up Display

After power-on, the power indicator light blinks in 500 ms cycles for approx. 3 seconds.

15.2.2 Power Failure Countermeasure

The non-volatile IC memory backs up the setting data. However, output volume settings are excluded.

15.2.3 Self-Diagnosis

The watchdog timer monitors runaway and halt of the program, and when an abnormality is detected, it resets the MCU and initializes the instrument.

15.2.4 Automatic Cold Junction Temperature Compensation

Detect the temperature of the connection terminal between the thermocouple and the instrument, and make it the same as if the reference contact is always set to 0°C (32°F). (Only valid for channels for which thermocouple input is selected.)

15.2.5 PV Filter Time Constant Setting

This is a function to stabilize the PV of the process (pressure, flow rate, etc.) where the PV fluctuation before the PV filter processing is performed by performing the temporary delay calculation of the PV before the PV filter processing with the filter function on the software.

When PV before PV filter processing changes stepwise as shown in (Fig. 15.2.5-1), if PV time constant (T) is set, PV filter will be set after T seconds as shown in (Fig. 15.2.5-2). It changes to reach 63% of the PV after treatment.

If the set value is too large, the control result may be adversely affected by the delay in response.

PV filter time constant: 0.0 to 10.0 seconds

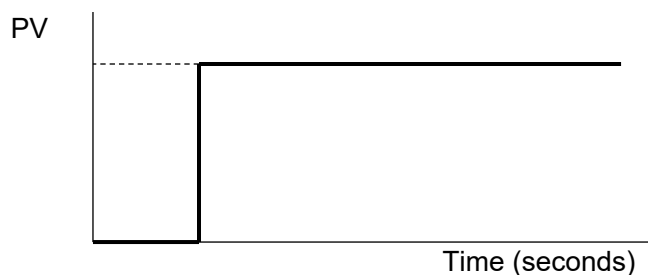

(Fig. 15.2.5-1)

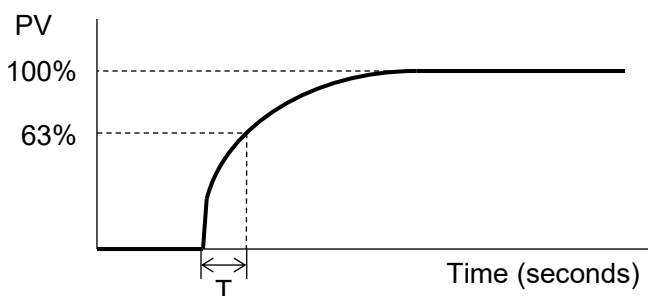

(Fig. 15.2.5-2)

15.2.6 Moving Average Count Setting

This function stabilizes the indicated value by averaging the input value that fluctuates due to noise.
Number of moving averages: 1 to 10

15.2.7 Overscale

In the case of the following input range, overscale will occur and B1: Input error (overscale) of status flag 1 will be set to "1: Error". However, measurement continues during overscale.

Refer to the relationship between sensor error, overscale, underscale, and measurement (Fig. 15.2.9-1). (P.15-5)

For thermocouple input (no decimal point)

Rated high limit to Input range high limit + 50°C (90°F)

For thermocouple input (with decimal point) and RTD input

Rated high limit to Input range high limit + 50.0°C (90.0°F)

For direct current input and DC voltage input

Scaling high limit to Scaling high limit + Scaling width × 10%

15.2.8 Underscale

In the case of the following input range, underscale will occur and B5: Input error (underscale) of status flag 1 will be set to "1: Error". However, measurement continues during underscale.

Refer to the relationship between sensor error, overscale, underscale, and measurement (Fig. 15.2.9-1). (P.15-5)

For thermocouple input (no decimal point)

Input range low limit - 50°C (90°F) to Rated low limit

For thermocouple input (with decimal point) and RTD input

Input range low limit - (Input span × 1%) °C (°F) to Rated low limit

For direct current input and DC voltage input

Scaling low limit - Scaling width × 1% to Scaling low limit

15.2.9 Sensor Error

In the following cases, a sensor error occurs, "1: Abnormal" is set to B5: Sensor error in status flag 2, and the control output is turned off.

Sensor error condition for thermocouple input (no decimal point)

When the input range low limit is less than -50°C (90°F) and exceeds the input range high limit +50°C (90°F)

At this time, PV is fixed to the of input range low limit -50°C (90°F)-1 digit and the input range high limit +50°C (90°F)+1 digit.

Sensor error condition for thermocouple input (with decimal point) and RTD input

When the input range low limit is less than -50°C (90°F) and exceeds the input range high limit +50°C (90°F)

At this time, PV is fixed to the of input range low limit -50°C (90°F)-1 digit and the input range high limit +50°C (90°F)+1 digit.

Sensor error condition for direct current input and DC voltage input

When 4 to 20 mA DC and 1 to 5 V DC

Scaling low limit – Scaling width × 1% or less

At this time, PV is fixed to Scaling lower limit - Scaling width × 1%-1 digit.

When 0 to 1 V DC

Scaling high limit + Scaling width × 10% or more

At this time, PV is fixed Scaling high limit + scaling width × 1% + 1 digit.

When 0 to 20 mA DC, 0 to 5 V DC and 0 to 10 V DC

Value at 0 mA DC or 0 V DC input

Relationship between sensor error, overscale and underscale, and measurement

For input K: -200 to 1370°C

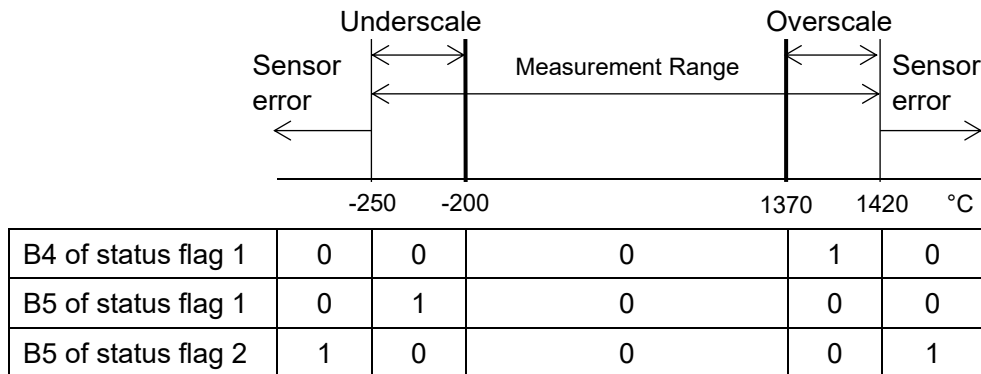

(Fig. 15.2.9-1)

15.2.10 Cold Junction Error

If the internal cold junction temperature is less than -10°C (14°F) or more than 50°C (122°F), a cold junction error will occur and B4: Cold junction error of status flag 2 will be "1: Error". Set. (Valid only for channels for which thermocouple input is selected)

15.2.11 ADC Error

If there is an abnormality such as a failure in the internal circuit, an ADC error occurs, B6: ADC error of status flag 2 is set to "1: Error".

At this time, PV becomes 32767.

15.2.12 Contact Switching Total Number of Times

The control output ON/OFF count can be integrated and measured.

ON/OFF is set as one time and totaling is performed.

This allows you to grasp the approximate contact life as the number of switching times of the switch used externally. However, since the saving cycle is 1 hour, the number of times within 1 hour may not be saved due to a power failure.

Contact switching total number of times: 10 minutes per count

15.2.13 Error History

When an error occurs, the bit ON/OFF and accumulated energization time are saved for the past 10 times.

Error history exists for each channel, and device common errors are saved in the error history of all channels.

Total energizing time: 1 hour/count

Bit	Error content		
B0	Undefined	Indefinite	
B1	Undefined	Indefinite	
B2	Undefined	Indefinite	
B3	Undefined	Indefinite	
B4	Undefined	Indefinite	
B5	Undefined	Indefinite	
B6	Undefined	Indefinite	
B7	Sensor error	0: Normal	1: Error
B8	Input error (Overscale)	0: Normal	1: Error
B9	Input error (Underscale)	0: Normal	1: Error
B10	Cold junction error	0: Normal	1: Error
B11	Non-volatile IC memory error	0: Normal	1: Error
B12	ADC error	0: Normal	1: Error
B13	Undefined	Indefinite	
B14	Undefined	Indefinite	
B15	Undefined	Indefinite	

16 Maintenance

You can use the console software (SWC-QTC101M) to check the error history, and so on.
Useful for failure prediction maintenance.

Error history

Click [Error history] of [Main screen] tab → [Error history].

Display the Error history screen.

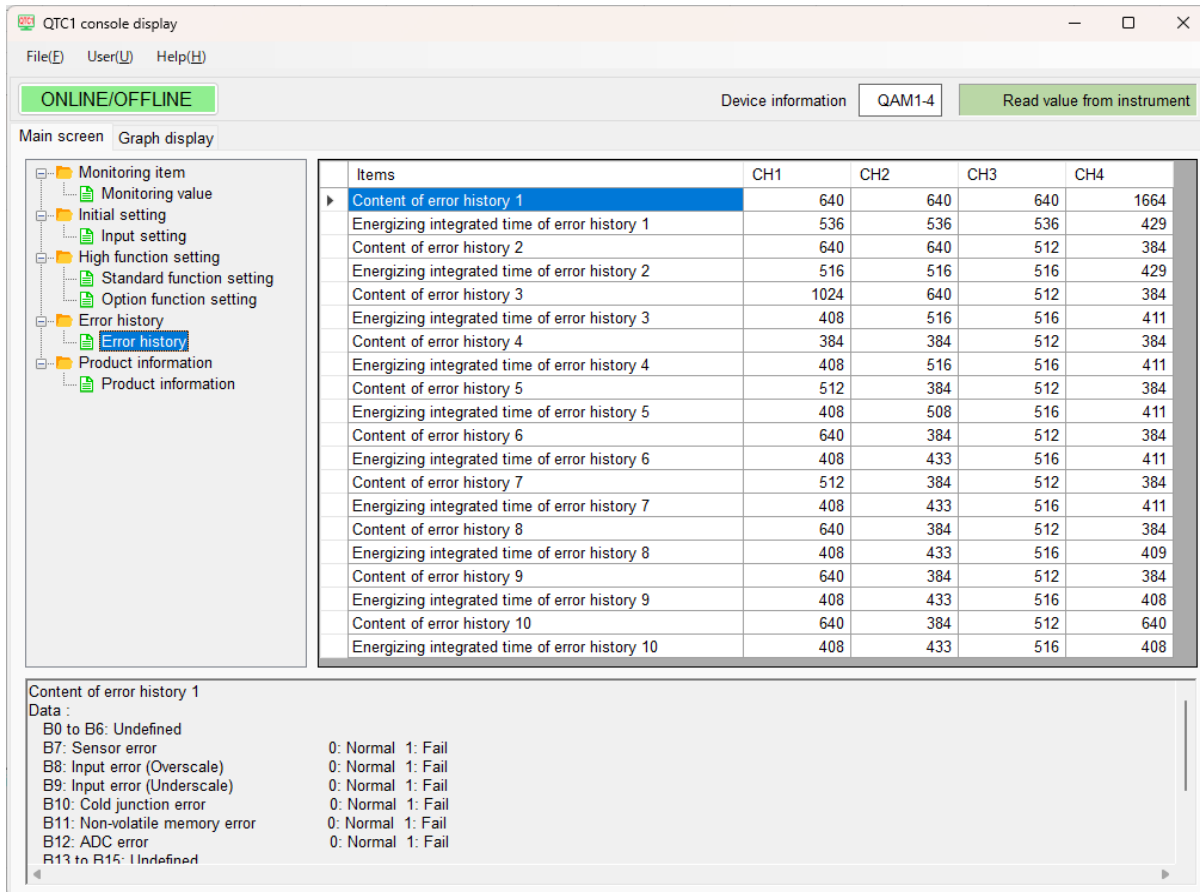

(Fig. 16-1)

Content of error history1 to 10, Energizing integrated time of error history1 to 10

The types of error history for the last 10 times and the integrated energizing time when an error occurs are displayed.

It can be used for future predictions from past error history.

Types of error history

The types of error history are shown below.

Bit	Error history types and data	
B0	Undefined	Indefinite
B1	Undefined	Indefinite
B2	Undefined	Indefinite
B3	Undefined	Indefinite
B4	Undefined	Indefinite
B5	Undefined	Indefinite
B6	Undefined	Indefinite
B7	Sensor error	0: Normal 1: Error
B8	Input error (Overscale)	0: Normal 1: Error
B9	Input error (Underscale)	0: Normal 1: Error
B10	Cold junction error	0: Normal 1: Error
B11	Non-volatile IC memory error	0: Normal 1: Error
B12	ADC error	0: Normal 1: Error
B13	Undefined	Indefinite
B14	Undefined	Indefinite
b15	Undefined	Indefinite

Error history display

Error history is updated each time an error occurs. Error history 1 is always the latest.

After the 11th time, delete the old Error history.

Example: Error history 1 is deleted the 11th time and Error history 2 is deleted the 12th time.

Number of error										
	1st	2nd	3rd		8th	9th	10th	11th	12th	
Error history										
Error history 1	1st	2nd	3rd		8th	9th	10th	11th	12th	
Error history 2		1st	2nd		7th	8th	9th	10th	11th	
Error history 3			1st		6th	7th	8th	9th	10th	
Error history 4					5th	6th	7th	8th	9th	
Error history 5					4th	5th	6th	7th	8th	
Error history 6					3rd	4th	5th	6th	7th	
Error history 7					2nd	3rd	4th	5th	6th	
Error history 8					1st	2nd	3rd	4th	5th	
Error history 9						1st	2nd	3rd	4th	
Error history 10							1st	2nd	3rd	
Delete error history								1st	2nd	

Integral electrification time • Product information

Click [Product information] of [Main screen] tab → [Product information].

Display the Product information screen.

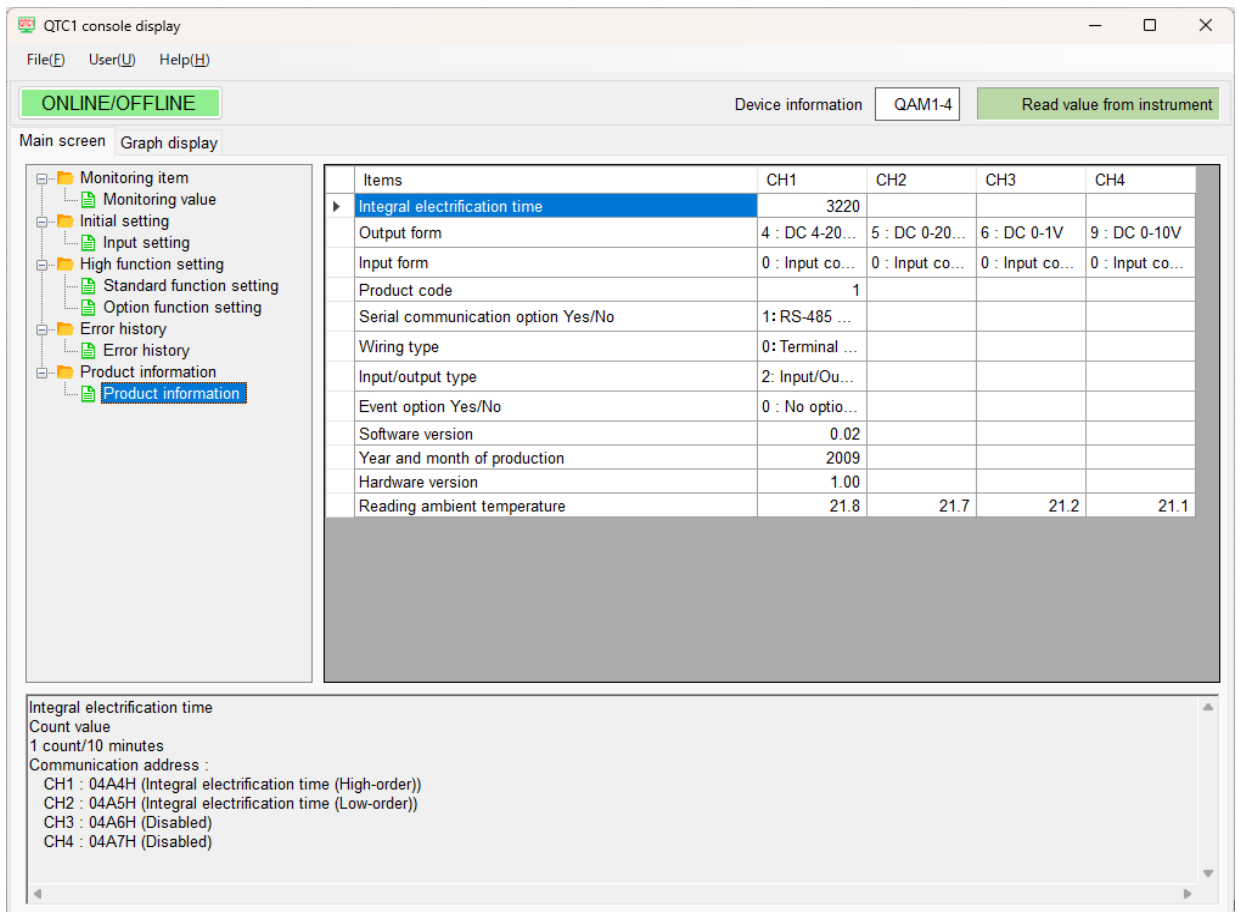

(Fig. 16-2)

Integral electrification time

It can be used to check the product life of the control module itself.

Product information

It can check the product information from the output form, input form, and product code.

Item	Product information example
Product code	Product code
Communication option	0: No power supply / communication option
Wiring type	0: Terminal block type
Input/Output Type	2: Input/Output: 4 points each
Event option	0: No event option
Software version	Ver. 1.00
Year and month of production	2409: September 2024
Hardware version	Ver. 1.00

17 Specifications

17.1 Standard Specifications

Rating

Rated scale	Input Range		Resolution
	Input		
	K	-200 to 1370°C -328 to 2498°F	1°C (°F)
	K	-200.0 to 400.0°C -328.0 to 752.0°F	0.1°C (°F)
	J	-200 to 1000°C -328 to 1832°F	1°C (°F)
	R	0 to 1760°C 32 to 3200°F	1°C (°F)
	S	0 to 1760°C 32 to 3200°F	1°C (°F)
	B	0 to 1820°C 32 to 3308°F	1°C (°F)
	E	-200 to 800°C -328 to 1472°F	1°C (°F)
	T	-200.0 to 400.0°C -328.0 to 752.0°F	0.1°C (°F)
	N	-200 to 1300°C -328 to 2372°F	1°C (°F)
	PL-II	0 to 1390°C 32 to 2534°F	1°C (°F)
	C(W/Re5-26)	0 to 2315°C 32 to 4199°F	1°C (°F)
	Pt100	-200.0 to 850.0°C -328.0 to 1562.0°F	0.1°C (°F)
	0 to 1 V DC	-32768 to 32767 (Scaling possible)	1
	4 to 20 mA DC	-32768 to 32767 (Scaling possible)	1
	0 to 20 mA DC	-32768 to 32767 (Scaling possible)	1
	0 to 5 V DC	-32768 to 32767 (Scaling possible)	1
	1 to 5 V DC	-32768 to 32767 (Scaling possible)	1
	0 to 10 V DC	-32768 to 32767 (Scaling possible)	1

Scaling possible.

Input

Input	Thermocouple input	K, J, R, S, B, E, T, N, C (W/Re5-26) (JIS C1602-2015) PL-II (ASTM E1751M-15) External resistance: 100 Ω or less (B 40 Ω or less)
	RTD input	Pt100 3-wire type (JIS C1604-2013) Allowable input lead wire resistance: 10 Ω or less per wire
	Direct current input	0 to 20 mA DC, 4 to 20 mA DC Input impedance: 50 Ω Allowable input current: 50 mA or less
	DC voltage input	0 to 1 V DC Input impedance: 1 M Ω or more Allowable input voltage: 5 V DC or less Allowable signal source resistance: 2 k Ω or less
		0 to 5 V DC, 1 to 5 V DC, 0 to 10 V DC Input impedance: 100 k Ω or more Allowable input voltage: 15 V DC or less Allowable signal source resistance: 100 Ω or less

Output

Output	DC current output	4 to 20 mA DC, 0 to 20 mA DC Load resistance: Max. 550 Ω Non-isolated between power supply and output
	DC voltage output	0 to 1 V DC, 0 to 5 V DC, 1 to 5 V DC, 0 to 10 V DC Allowable load resistance: 1 k Ω or more Non-isolated between power supply and output

Power supply

Power supply voltage	24 V DC Allowable voltage fluctuation: 20 to 28 V DC
Power consumption	5 W or less
Inrush current	Max. 10 A

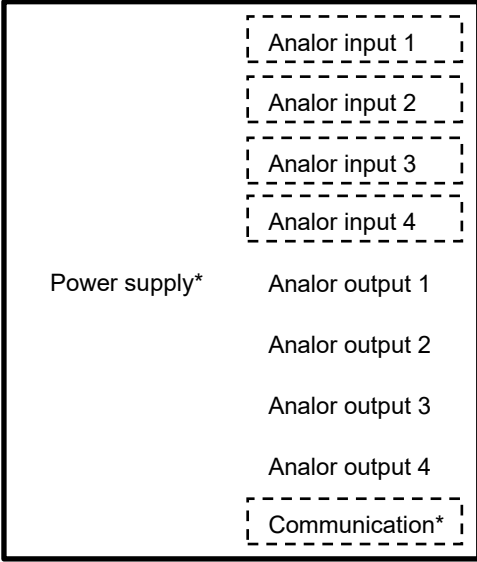
<p>Circuit insulation configuration</p>	 <p style="text-align: center;">(Fig. 17.1-1)</p> <p style="text-align: right;">*: When option is added : Functional insulation</p>
<p>Insulation resistance</p>	<p>500 V DC 10 MΩ or more</p>
<p>Dielectric strength</p>	<p>Between Power terminal – Ground (GND): 1.5 kV AC for 1 minute Between Power terminal – Ground (GND): 1.5 kV AC for 1 minute Between Input terminal – Power terminal: 750 V AC for 1 minute</p>

Recommended Environment

<p>Ambient temperature</p>	<p>-10 to 50°C (no condensation or freezing)</p>
<p>Ambient humidity</p>	<p>35 to 85%RH (no condensation)</p>
<p>Environmental specification</p>	<p>RoHS directive compliant</p>

General Structure

Weight	Approx. 170 g					
External dimensions	30 × 100 × 85 mm (W × H × D excluding protrusion) 95 mm depth when the terminal cover is attached					
Mounting type	DIN rail mounting type					
Case	Flame-resistant resin, Color: Black					
Panel	Polycarbonate sheet					
Applicable standard	<table border="1"> <tr> <td>EN</td> <td>EN61010-1 (Pollution degree 2)</td> </tr> <tr> <td>EC Directive</td> <td>EMI: EN61326 Radiated interference field strength: EN55011 Group1 ClassA Terminal noise voltage: EN55011 Group1 ClassA EMS: EN61326</td> </tr> </table>		EN	EN61010-1 (Pollution degree 2)	EC Directive	EMI: EN61326 Radiated interference field strength: EN55011 Group1 ClassA Terminal noise voltage: EN55011 Group1 ClassA EMS: EN61326
EN	EN61010-1 (Pollution degree 2)					
EC Directive	EMI: EN61326 Radiated interference field strength: EN55011 Group1 ClassA Terminal noise voltage: EN55011 Group1 ClassA EMS: EN61326					

Setting Structure

Communication specification setting	Set the communication speed, data bit, parity, and stop bit, using the DIP switch.
Module address setting	Set the module address 0 to F (1 to 16) with the rotary switch. The value obtained by adding 1 to the value of the setting rotary switch becomes the module address.
CUnet communication specification setting	The station address, communication speed, master address, and number of occupied (OWN) items are set by the DIP switches (SW10, SW11) on the board mounted in the base section.

Standard Function

<p>Input scaling function</p>	<p>Valid for DC voltage input and direct current input.</p> <p>Set the input (0 to 100 %) range from the low limit of input scaling to the high limit of input scaling.</p> <p>The response is PV in the range of -1 to 110 %. However, if the value of -1 to 110 % exceeds the range of -32768 to 32767, the response will be the value limited by -32768 or 32767.</p> <p>If the input scaling high limit value and the input scaling low limit value are set to the same value, the value will be that of the input scaling low limit value.</p> <p>For output-only type, PV is always 0.</p>
<p>Output scaling function</p>	<p>Set the output volume (0 to 100 %) in the range from the low limit of output scaling to the high limit of output scaling.</p> <p>If the output volume outside the range is set, it becomes invalid and the previous output volume is retained.</p> <p>If the output scaling high limit and output scaling low limit are set to the same value, the output is 0 %.</p> <p>For input-only type, output is OFF.</p>
<p>Sensor correction factor setting</p>	<p>Set the slope of the sensor input value.</p> <p>0.000 to 10.000</p>
<p>Sensor correction setting</p>	<p>Set the sensor correction value.</p> <p>If the temperature at the control location and the temperature at the sensor installation location are different, PV is shifted and corrected. However, it is valid within the input rated range regardless of the sensor correction value.</p> <p>-100.0 to 100.0°C (-180.0 to 180.0°F)</p> <p>when direct current and DC voltage input, -1000 to 1000</p>

Attached Function

Warm up indication	The power indicator flashes every 500 ms for about 3 seconds after the power is turned on.
Power failure countermeasure	The setting data is backed up in the non-volatile IC memory.
Self-diagnosis	The watchdog timer monitors runaway and halt of the program, and when an abnormality is detected, it resets the MCU and initializes the instrument.
Automatic cold junction temperature compensation	Detect the temperature of the connection terminal between the thermocouple and the instrument, and make it the same as if the reference contact is always set to 0°C (32°F). (Only valid for channels for which thermocouple input is selected.)
PV filter time constant setting	The fluctuation of PV due to noise is reduced by the digital first-order low-pass filter.
Number of moving average setting	Stabilizes the indicated value by averaging the values that PV changes due to noise.
Overscale	<p>In the case of the following input range, overscale will occur and B1: Input error (overscale) of status flag 1 will be set to "1: Error". However, measurement continues during overscale.</p> <p>Refer to the relationship between sensor error, overscale, underscale, and measurement (Fig. 17.1-2). (P.17-8)</p> <p>For thermocouple input (no decimal point) Rated high limit to Input range high limit + 50°C (90°F)</p> <p>For thermocouple input (with decimal point) and RTD input Rated high limit to Input range high limit + 50.0°C (90.0°F)</p> <p>For direct current input and DC voltage input Scaling high limit to Scaling high limit + Scaling width × 10%</p>
Underscale	<p>In the case of the following input range, underscale will occur and B5: Input error (underscale) of status flag 1 will be set to "1: Error". However, measurement continues during underscale.</p> <p>Refer to the relationship between sensor error, overscale, underscale, and measurement (Fig. 17.1-2). (P.17-8)</p> <p>For thermocouple input (no decimal point) Input range low limit - 50°C (90°F) to Rated low limit</p> <p>For thermocouple input (with decimal point) and RTD input Input range low limit - (Input span × 1%) °C (°F) to Rated low limit</p> <p>For direct current input and DC voltage input Scaling low limit - Scaling width × 1% to Scaling low limit</p>

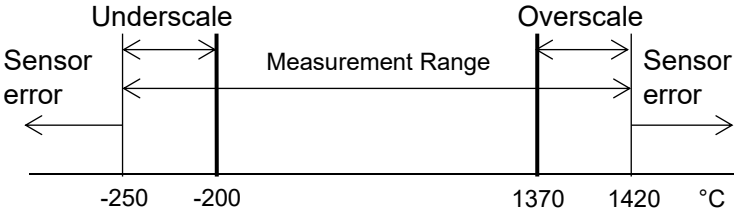
<p>Sensor Error</p>	<p>In the following cases, a sensor error occurs, "1: Abnormal" is set to B5:</p> <p>Sensor error in status flag 2.</p> <p>Sensor error condition for thermocouple input (no decimal point)</p> <p>When the input range low limit is less than -50°C (90°F) and exceeds the input range high limit +50°C (90°F)</p> <p>At this time, PV is fixed to the of input range low limit -50°C (90°F)-1 digit and the input range high limit +50°C (90°F)+1 digit.</p> <p>Sensor error condition for thermocouple input (with decimal point) and RTD input</p> <p>When the input range low limit is less than -50°C (90°F) and exceeds the input range high limit +50°C (90°F)</p> <p>At this time, PV is fixed to the of input range low limit -50°C (90°F)-1 digit and the input range high limit +50°C (90°F)+1 digit.</p> <p>Sensor error condition for direct current input and DC voltage input</p> <p>When 4 to 20 mA DC and 1 to 5 V DC</p> <p>Scaling low limit – Scaling width × 1% or less</p> <p>At this time, PV is fixed to Scaling lower limit - Scaling width × 1%-1 digit.</p> <p>When 0 to 1 V DC</p> <p>Scaling high limit + Scaling width × 10% or more</p> <p>At this time, PV is fixed Scaling high limit + scaling width × 1% + 1 digit.</p> <p>When 0 to 20 mA DC, 0 to 5 V DC and 0 to 10 V DC</p> <p>Value at 0 mA DC or 0 V DC input</p> <p>Relationship between sensor error, overscale and underscale, and measurement</p> <p>For input K: -200 to 1370°C</p> <div style="text-align: center;">  </div> <table border="1" style="margin-left: auto; margin-right: auto;"> <tr> <td>B4 of status flag 1</td> <td>0</td> <td>0</td> <td>0</td> <td>1</td> <td>0</td> </tr> <tr> <td>B5 of status flag 1</td> <td>0</td> <td>1</td> <td>0</td> <td>0</td> <td>0</td> </tr> <tr> <td>B5 of status flag 2</td> <td>1</td> <td>0</td> <td>0</td> <td>0</td> <td>1</td> </tr> </table> <p>(Fig. 17.1-2)</p>	B4 of status flag 1	0	0	0	1	0	B5 of status flag 1	0	1	0	0	0	B5 of status flag 2	1	0	0	0	1
B4 of status flag 1	0	0	0	1	0														
B5 of status flag 1	0	1	0	0	0														
B5 of status flag 2	1	0	0	0	1														
<p>Cold junction error</p>	<p>If the internal cold junction temperature is less than -10°C (14°F) or more than 50°C (122°F), the cold junction error occurs and "1: Error" is set to B4: Cold junction error in status flag 2. (Valid only for channels for which thermocouple input is selected)</p>																		
<p>ADC error</p>	<p>If there is an abnormality such as a failure in the internal circuit, the ADC becomes abnormal, sets "1: Error" in status flag 2, B6: ADC error.</p> <p>At this time, PV becomes 32767.</p>																		

<p>Total energizing time measurement function</p>	<p>It can check the time that the power is on. The accumulated time is saved every 10 minutes. It can grasp the approximate usage time from the accumulated time. However, since the save cycle is 10 minutes, the time within 10 minutes may not be saved due to a power failure. Total energizing time: 10 minutes/count</p>																																																			
<p>Error history</p>	<p>When an error occurs, the bit ON/OFF and accumulated energization time are saved for the past 10 times. Error history exists for each channel, and device common errors are saved in the error history of all channels. Total energizing time: 1 hour/count</p> <table border="1" data-bbox="488 645 1444 1473"> <thead> <tr> <th>Bit</th> <th colspan="2">Error content</th> </tr> </thead> <tbody> <tr><td>B0</td><td>Undefined</td><td>Indefinite</td></tr> <tr><td>B1</td><td>Undefined</td><td>Indefinite</td></tr> <tr><td>B2</td><td>Undefined</td><td>Indefinite</td></tr> <tr><td>B3</td><td>Undefined</td><td>Indefinite</td></tr> <tr><td>B4</td><td>Undefined</td><td>Indefinite</td></tr> <tr><td>B5</td><td>Undefined</td><td>Indefinite</td></tr> <tr><td>B6</td><td>Undefined</td><td>Indefinite</td></tr> <tr><td>B7</td><td>Sensor error</td><td>0: Normal 1: Error</td></tr> <tr><td>B8</td><td>Input error (Overscale)</td><td>0: Normal 1: Error</td></tr> <tr><td>B9</td><td>Input error (Underscale)</td><td>0: Normal 1: Error</td></tr> <tr><td>B10</td><td>Cold junction error</td><td>0: Normal 1: Error</td></tr> <tr><td>B11</td><td>Non-volatile IC memory error</td><td>0: Normal 1: Error</td></tr> <tr><td>B12</td><td>ADC error</td><td>0: Normal 1: Error</td></tr> <tr><td>B13</td><td>Undefined</td><td>Indefinite</td></tr> <tr><td>B14</td><td>Undefined</td><td>Indefinite</td></tr> <tr><td>B15</td><td>Undefined</td><td>Indefinite</td></tr> </tbody> </table>	Bit	Error content		B0	Undefined	Indefinite	B1	Undefined	Indefinite	B2	Undefined	Indefinite	B3	Undefined	Indefinite	B4	Undefined	Indefinite	B5	Undefined	Indefinite	B6	Undefined	Indefinite	B7	Sensor error	0: Normal 1: Error	B8	Input error (Overscale)	0: Normal 1: Error	B9	Input error (Underscale)	0: Normal 1: Error	B10	Cold junction error	0: Normal 1: Error	B11	Non-volatile IC memory error	0: Normal 1: Error	B12	ADC error	0: Normal 1: Error	B13	Undefined	Indefinite	B14	Undefined	Indefinite	B15	Undefined	Indefinite
Bit	Error content																																																			
B0	Undefined	Indefinite																																																		
B1	Undefined	Indefinite																																																		
B2	Undefined	Indefinite																																																		
B3	Undefined	Indefinite																																																		
B4	Undefined	Indefinite																																																		
B5	Undefined	Indefinite																																																		
B6	Undefined	Indefinite																																																		
B7	Sensor error	0: Normal 1: Error																																																		
B8	Input error (Overscale)	0: Normal 1: Error																																																		
B9	Input error (Underscale)	0: Normal 1: Error																																																		
B10	Cold junction error	0: Normal 1: Error																																																		
B11	Non-volatile IC memory error	0: Normal 1: Error																																																		
B12	ADC error	0: Normal 1: Error																																																		
B13	Undefined	Indefinite																																																		
B14	Undefined	Indefinite																																																		
B15	Undefined	Indefinite																																																		
<p>Console communication</p>	<p>Connect a communication cable (commercial item) to the console communication connector, and The following operations can be performed from an external computer using the software (SWC-QTC101M). (1) Reading and setting of SV, PID and various set values (2) PV and operation status reading</p> <table border="1" data-bbox="488 1816 1463 1966"> <tr> <td>Communication protocol</td> <td>MODBUS RTU</td> </tr> <tr> <td>Communication cable</td> <td>USB - micro USB Type-B(commercial item)</td> </tr> <tr> <td>Software</td> <td>Console software (SWC-QTC101M)</td> </tr> </table>	Communication protocol	MODBUS RTU	Communication cable	USB - micro USB Type-B(commercial item)	Software	Console software (SWC-QTC101M)																																													
Communication protocol	MODBUS RTU																																																			
Communication cable	USB - micro USB Type-B(commercial item)																																																			
Software	Console software (SWC-QTC101M)																																																			

SIF communication function	Can be connected as a slave module for SIF function of control module QTC1 series. (Master function not supported)
----------------------------	--------------------------------------------------------------------------------------------------------------------

Other Item

Accessories	Mounting and wiring instruction manual: 1 Line cap: 1 Power supply terminal cover: 1 (Included when adding "With power supply / host communication function" and "With power supply / CUnet communication function")
Sold separately	Shunt resistor: RES-S01-050 50 Ω Front terminal cover: TC-QTC (*) Termination resistor: RES-S07-100 100 Ω

(*): QAM1 has the same case shape as QTC1, so the terminal cover of QTC1 is used.

17.2 Optional Specifications

Power supply / RS-485 communication function	Perform the following operations from the external computer.		
	(1) Reading and setting of various set values		
	(2) PV and operation status reading		
	(3) Change of function		
	Communication line	EIA RS-485 (C5 option)	
	Communication method	Half-duplex communication	
	Synchronization method	Start-stop synchronization	
	Communication protocol	MODBUS RTU or SIF specifications can be selected by DIP switch	
Communication speed	9600 bps, 19200 bps, 38400 bps or 57600 bps can be selected by DIP switch		
Data bit/Parity/Stop bit	Select the following with the DIP switch Data bit: 8 Parity: Even, Odd, No parity Stop bit: 1 or 2		
Communication response delay time	Set the delay time to return the response from the module after receiving the command from the host. 0 to 1000 ms		
Power supply / CUnet communication function	Connection type		Multi-drop
	Communication method		2-wire half-duplex
	Synchronization method		Bit-synchronous
	Error detection		CRC-16
	Number of occupied slave addresses		1
	Maximum number of connected nodes		64 nodes
	Communication speed, Communication distance	Communication speed	Maximum network length
		12 Mbps	100 m
		6 Mbps	200 m
		3 Mbps	300 m
	Isolation method		Pulse transformer isolation
Impedance		100 Ω	
Termination resistance		Last connection, set by CUnet slave This instrument is not equipped.	

18 Troubleshooting

If any malfunctions occur, refer to the following items after checking that power is being supplied to the master module and slave module.

18.1 Host Communication

Problem	Possible Cause	Solution
Cannot communicate.	Is the communication cable disconnected?	Check the communication cable.
	Is the communication cable wiring correct?	Refer to "7 Wiring (P.7-1)" or "13.4 Wiring (P.13-8)", and check the communication cable.
	Is there any disconnection or contact failure of the communication cable?	Check the communication cable.
	Is communication speed of the master and slave same?	Refer to "5.1.1 Setting of Communication Specifications (P.5-1)", and check the communication speed of the master and slave.
	Are data bits, parity, and stop bits of the master and slave same?	Refer to "5.1.1 Setting of Communication Specifications (P.5-1)", and check the data bit, parity, and stop bit of the master and slave.
	Is the module address of the command and slave same?	Refer to "5.1.2 Setting of Module Address (P.5-4)", and check the module address of the command and slave.
	Are there any slaves that have the same module address?	Refer to "5.1.2 Setting of Module Address (P.5-4)", and check the module address.
	Is the program considering the transmission timing?	Refer to "9. Communication Procedure (P.9-1)", and check the program.
Communication is possible, but a negative acknowledgement is returned.	Are sending a command code that does not exist?	Refer to "11.1 Communication Command List (P.11-1)", and check the command code.
	Is the data of the write command exceeding the setting range?	Refer to "11.1 Communication Command List (P.11-1)", and check the setting range of write command.
	Is it not possible to write?	Check the state of a slave.

18.2 CUnet Communication

Problem	Possible Cause	Solution
Cannot communicate.	Is the communication line wiring correct?	Refer to “14.4.3 Wiring Example of CUnet Communication Line (P.14-10)”, and check the wiring of the communication line.
	Is the termination resistance attached to the last module in the communication line?	Refer to “14.4.3 Wiring Example of CUnet Communication Line (P.14-10)”, and attach the termination resistance to the last module in the communication line.
	Is the LAN cable a straight cable?	If the LAN cable is a crossover cable, communication is not possible. Use a straight cable.
	Is the station address correct?	Refer to “14.2 Setting CUnet communication specifications (P.14-3)”, and check the settings.
	Are there duplicate station addresses?	Refer to “14.2 Setting CUnet communication specifications (P.14-3)” and set the station address to avoid duplication.
	Is the communication speed between the host system (master) and the module the same?	Refer to “14.2 Setting CUnet communication specifications (P.14-3)” and check the communication speed.

18.3 PV Reading Value

Problem	Possible Cause	Solution
PV reading is abnormal or unstable.	Are the sensor input and temperature unit (°C/°F) selection correct?	Select the correct sensor input and temperature unit (°C/°F).
	Is the sensor correction factor or sensor correction value set appropriately?	Set an appropriate sensor correction factor or sensor correction value.
	Are the sensor specifications correct?	Use a sensor with appropriate specifications.
	Is AC leaking to the sensor?	Make the sensor non-grounded.
	Is there a device nearby that causes inductive interference or noise?	Keep away from device that may cause inductive interference or noise.

18.4 Status Flag 1

Problem	Possible Cause	Solution
"1: Error" is set in B4: Input error (Overscale).	It is an overscale. Is PV over the input range high limit (scaling high limit for direct current input and DC voltage input)?	Check the input signal source is normal.
"1: Error" is set in B5: Input error (Underscale).	It is an underscale. Is PV below the input range low limit (scaling low limit for direct current input and DC voltage input)?	Check the input terminal wiring and input signal source are normal.
"1: Error" is set in B15: Non-volatile IC memory error.	The nonvolatile IC memory is defective.	Contact our agency or us.

18.5 Status Flag 2

Problem	Possible Cause	Solution
<p>"1: Error" is set in B4: Cold junction error.</p>	<p>It is a cold junction error. If the internal cold junction temperature is lower than -10°C (14°F) or higher than 50°C (122°F), a cold junction error will occur.</p>	<p>Check the installation environment such as the ambient temperature of the instrument.</p>
<p>"1: Error" is set in B5: Sensor error.</p>	<p>It is a sensor error. Is the sensor burn out?</p>	<p>Replace each sensor. How to check whether the sensor is burnt out</p> <ul style="list-style-type: none"> • For thermocouple If the input terminals of this instrument are short-circuited and the around room temperature is indicated, this instrument is normal and the sensor may be burn out. • For RTD If a resistance of approx. 100 Ω is connected to the input terminal (between A and B) of this instrument and the input terminal (between B and B) is short-circuited and the temperature is indicated as 0°C (32°F), this instrument is normal and the sensor may be burn out. • For DC voltage (0 to 1 V DC) If the input terminals of this instrument are short-circuited and the scaling low limit is indicated, this instrument is normal and the sensor may be burn out. • For direct current (4 to 20 mA DC) If the input terminals of this instrument input 4 mA DC and the scaling low limit is indicated, this instrument is normal and the sensor may be burn out. • For DC voltage (1 to 5 V DC) If the input terminals of this instrument input 1 V DC and the scaling low limit is indicated, this instrument is normal and the sensor may be burn out.

Problem	Possible Cause	Solution
<p>"1: Error" is set in B5: Sensor error.</p>	<p>It is a sensor error. Is the sensor burn out?</p>	<ul style="list-style-type: none"> • For direct current (0 to 20 mA DC) If the input terminals of this instrument input 4 mA DC and the input value is a value converted by scaling high and low limit settings, this instrument is normal and the sensor may be burn out. • For DC voltage (0 to 5 V DC, 0 to 10 V DC) If the input terminals of this instrument input 1 V DC and the input value is a value converted by scaling high and low limit settings, this instrument is normal and the sensor may be burn out.
<p>"1: Error" is set in B6: ADC error.</p>	<p>It is the internal circuit error.</p>	<p>Contact our agency or us.</p>

SHINKO TECHNOS CO., LTD.
OVERSEAS DIVISION

Head Office: 2-5-1, Senbahigashi, Minoo, Osaka, 562-0035, Japan

[URL] <https://shinko-technos.co.jp/e/>

Tel: +81-72-727-6100

[E-mail] overseas@shinko-technos.co.jp

Fax: +81-72-727-7006