

Control Module

QTC1-4

INSTRUCTION MANUAL



Shinko

Preface

Thank you for purchasing our control module [QTC1-4].

This manual contains instructions for the mounting, functions, operations and notes when operating the control module [QTC1-4].

To prevent accidents arising from the misuse of this instrument, please ensure the operator receives this manual

Notes

- This instrument should be used in accordance with the specifications described in the manual. If it is not used according to the specifications, it may malfunction or cause a fire.
- Be sure to follow the warnings, cautions and notices. If they are not observed, serious injury or malfunction may occur.
- The contents of this instruction manual are subject to change without notice.
- Care has been taken to ensure that the contents of this instruction manual are correct, but if there are any doubts, mistakes or questions, please inform our sales department.
- This instrument is designed to be installed on a DIN rail within a control panel indoors. If it is not, measures must be taken to ensure that the operator does not touch power terminals or other high voltage sections.
- Any unauthorized transfer or copying of this document, in part or in whole, is prohibited.
- Shinko Technos Co., Ltd. is not liable for any damage or secondary damage(s) incurred as a result of using this product, including any indirect damage.

SAFETY PRECAUTIONS (Be sure to read these precautions before using our products.)

The safety precautions are classified into categories: "Warning" and "Caution".

Depending on circumstances, procedures indicated by  Caution may result in serious consequences, so be sure to follow the directions for usage.



Warning

Procedures which may lead to dangerous conditions and cause death or serious injury, if not carried out properly.



Caution

Procedures which may lead to dangerous conditions and cause superficial to medium injury or physical damage or may degrade or damage the product, if not carried out properly.



Warning

- To prevent an electrical shock or fire, only Shinko or qualified service personnel may handle the inner assembly.
- To prevent an electrical shock, fire, or damage to instrument, parts replacement may only be undertaken by Shinko or qualified service personnel.



Safety Precautions

- To ensure safe and correct use, thoroughly read and understand this manual before using this instrument.
- This instrument is intended to be used for industrial machinery, machine tools and measuring equipment. Verify correct usage after purpose-of-use consultation with our agency or main office. (Never use this instrument for medical purposes with which human lives are involved.)
- External protection devices such as protective equipment against excessive temperature rise, etc. must be installed, as malfunction of this product could result in serious damage to the system or injury to personnel. Proper periodic maintenance is also required.
- This instrument must be used under the conditions and environment described in this manual. Shinko Technos Co., Ltd. does not accept liability for any injury, loss of life or damage occurring due to the instrument being used under conditions not otherwise stated in this manual.

Meaning of Warning Message on Model Label



Caution

If do not handle this instrument correctly, may suffer minor or moderate injury or property damage due to fire, malfunction, or electric shock. Please read this manual carefully and fully understand it before using it.



Caution with Respect to Export Trade Control Ordinance

To avoid this instrument from being used as a component in, or as being utilized in the manufacture of weapons of mass destruction (i.e. military applications, military equipment, etc.), please investigate the end users and the final use of this instrument.

In the case of resale, ensure that this instrument is not illegally exported.

Precautions for Use

1. Installation Precautions



Caution

This instrument is intended to be used under the following environmental conditions (IEC61010-1):

- Pollution degree 2

Ensure the mounting location corresponds to the following conditions:

- A minimum of dust, and an absence of corrosive gases
- No flammable, explosive gases
- No mechanical vibrations or shocks
- No exposure to direct sunlight, an ambient temperature of -10 to 50°C (14°F to 122°F) that does not change rapidly, and no icing
- An ambient non-condensing humidity of 35 to 85%RH
- No large capacity electromagnetic switches or cables through which large current is flowing
- No water, oil or chemicals or the vapors of these substances can come into direct contact with the unit.
- When installing this unit within a control panel, please note that ambient temperature of this unit – not the ambient temperature of the control panel – must not exceed 50°C (122°F).

Otherwise the life of electronic components (especially electrolytic capacitor) may be shortened.

* Avoid setting this instrument directly on or near flammable material even though the case of this instrument is made of flame-resistant resin.

2. Wiring Precautions



Caution

- Do not leave bits of wire in the instrument, because they could cause a fire and malfunction.
- When wiring, use a crimping pliers and a solderless terminal with an insulation sleeve in which an M3 screw fits.
- The terminal block of this instrument has a structure that is wired from the left side. Be sure to insert the lead wire into the terminal of the instrument from the left side and tighten the terminal screw.
- Tighten the terminal screw using the specified torque. If excessive force is applied to the screw when tightening, the screw or case may be damaged.
- Do not pull or bend the lead wire with the terminal as the base point during or after wiring work. It may cause malfunction.
- This instrument does not have a built-in power switch, circuit breaker and fuse. It is necessary to install a power switch, circuit breaker and fuse near the instrument.
(Recommended fuse: Time-lag fuse, rated voltage 250 V AC, rated current 2 A)
- When wiring the power supply (24 VDC), do not confuse the polarities.
- Do not apply a commercial power source to the sensor which is connected to the input terminal nor allow the power source to come into contact with the sensor.
- Use the thermocouple and compensation lead wire that match the sensor input specifications of the instrument.
- Use a RTD of 3-conducting wire type that meets the sensor input specifications of this instrument.
- When using a relay contact output type, externally use a relay according to the capacity of the load to protect the built-in relay contact.
- Separate the input line (thermocouple, RTD, etc.) from the power line and load line.

3. Operation and Maintenance Precautions



Caution

- It is recommended that auto-tuning (AT) be performed on the trial run.
- Do not touch live terminals. This may cause electrical shock or problems in operation.
- Turn the power supply to the instrument OFF when retightening the terminal or cleaning. Working on or touching the terminal with the power switched ON may result in severe injury or death due to electrical shock.
- Use a soft, dry cloth when cleaning the instrument.
(Alcohol based substances may tarnish or deface the unit.)
- As the panel part is vulnerable, be careful not to put pressure on, scratch or strike it with a hard object.

4. Compliance with Safety Standards



Caution

- Use the recommended fuse as described in the instruction manual.
- For analog input
 - When inputting voltage or current, set the input type to match the input specification.
 - Do not use for measurement of circuits that fall into measurement categories II, III, or IV.
 - Do not use for measurement of objects to which a voltage exceeding 30 Vrms or 60 V DC is applied.
- If the instrument is used in a manner not specified by the manufacturer, the protection provided by the instrument may be impaired.
- Use equipment that is reinforced-insulated or double-insulated from the primary power supply for external circuits connected to this instrument.

The following abbreviations are used in the text, figures, and tables of this manual.

Symbol	Term
PV	Process variable (PV)
SV	Desired value (SV)
MV	Output manipulated variable (MV)
AT	Auto-tuning (AT)
CT	Current transformer (CT) [for heater burnout alarm (option)]

About description of reference page

In the case of "Refer to 2-2.", it is described as (P.2-2).

Contents

1	Overview	1-1
1.1	Overview of Control Module QTC1-4	1-1
1.2	Description of Module.....	1-2
1.3	System Configuration	1-4
1.3.1	Using Control Module Alone	1-4
1.3.2	Connecting to Host Computer	1-5
1.3.3	Connecting to PLC	1-7
1.3.4	Connecting to CUnet	1-10
1.4	Parameter Passing.....	1-11
1.4.1	Using the Control Module QTC1-4P (with power supply / communication option).....	1-11
1.4.2	Using the Communication Expansion Module QMC1-C□.....	1-11
2	Model.....	2-1
2.1	Model	2-1
2.2	How to Read the Model Label	2-3
3	Name and Functions	3-1
3.1	Control Module QTC1-4	3-1
4	Procedure Before Starting Operation.....	4-1
5	Communication Parameter Setting	5-1
5.1	Communication Parameter Setting.....	5-1
5.1.1	Selection of Communication Specifications	5-1
5.1.2	Selection of Module Address	5-4
5.1.3	Setting of CUnet communication specification.....	5-6
6	Mounting.....	6-1
6.1	Selection of Location	6-2
6.2	External Dimensions (Scale: mm)	6-2
6.2.1	Control Module QTC1-4.....	6-2
6.2.2	CT (Current transformer)	6-4
6.3	Mounting.....	6-5
7	Wiring	7-1
7.1	Recommended Terminal and Recommended Rod Terminal	7-1
7.2	Using Terminal Cover Precaution	7-2
7.3	Terminal Arrangement	7-2
7.3.1	Input and Output Terminal Arrangement	7-2
7.3.2	Power Supply and Serial Communication Terminal Arrangement	7-4
7.3.3	Power Supply and CUnet Communication Terminal Arrangement.....	7-4
7.3.4	Event Input and Output Terminal Arrangement	7-5
7.4	Wiring.....	7-6
7.4.1	Wiring for Power Supply and Serial Communication / CUnet Communication	7-6
7.4.2	Wiring for Input, Output and CT.....	7-9

7.4.3	Wiring for Event Input and Event Output	7-11
7.5	Connection of Host Computer and Control Module QTC1-4	7-12
7.5.1	Wiring Example for Using USB Communication Cable CMC-001-1 (Sold separately)	7-12
7.5.2	Wiring Example for Using Communication Converter IF-400 (Sold separately)	7-13
8	Setting of Specification	8-1
8.1	Preparation	8-1
8.1.1	Preparation of USB Communication Cable and Console Software	8-1
8.1.2	Connecting to Host Computer	8-1
8.2	Specification Setting	8-6
8.2.1	Monitoring Value Setting.....	8-8
8.2.2	Operation Parameters Setting	8-10
8.2.3	Control Setting.....	8-12
8.2.4	Alarm Parameters Setting.....	8-17
8.2.5	Input Setting	8-24
8.2.6	Output Setting.....	8-27
8.2.7	Standard Function Setting	8-30
8.2.8	Extension Function Selection	8-32
8.2.9	Option Function Setting	8-35
8.2.10	Detail Setting	8-38
9	Communication Procedure.....	9-1
10	MODBUS Protocol	10-1
10.1	Transmission Mode	10-1
10.2	Data Communication Interval	10-1
10.3	Message Configuration.....	10-1
10.4	Message Example	10-3
11	Communication Command List	11-1
11.1	Communication Command List	11-1
11.2	Data.....	11-21
11.2.1	Notes About Write/Read Command	11-21
11.2.2	Write Command.....	11-21
11.2.3	Read Command	11-21
11.3	Negative Acknowledgement	11-22
11.3.1	Error Code 2 (02H)	11-22
11.3.2	Error Code 3 (03H).....	11-22
11.3.3	Error Code 17 (11H).....	11-22
11.4	Notes on Programming Monitoring Software.....	11-22
11.4.1	How to Speed up the Scan Time	11-22
11.4.2	How to Read PID Parameters after AT or Start-up AT Finishes.....	11-22
11.4.3	Notes on Batch Transmission of All Setting Values.....	11-22
11.5	Initialization Items by Changing Settings.....	11-23
12	Operation.....	12-1
12.1	Control Permission	12-1
12.2	Set PID Constants (Execute AT)	12-3
12.2.1	Normal AT	12-4

12.2.2	Start-up AT	12-5
12.2.3	AT Gain Setting	12-6
12.2.4	Executing AT	12-6
12.3	Set Alarm	12-7
12.4	Correct Process Variable	12-9
12.5	Auto/Manual Control Switch	12-11
13	Communication with PLC Using SIF Function	13-1
13.1	Flow of Before Operation	13-2
13.2	PLC Communication Parameter Setting	13-3
13.3	Mounting	13-6
13.4	Wiring	13-8
13.4.1	Wiring for Power Supply and Serial Communication	13-8
13.4.2	Wiring for Input, Output and CT	13-10
13.4.3	Wiring for Event Input and Event Output	13-11
13.5	Connection of PLC and Control Module QTC1-4	13-12
13.6	Specification Setting	13-14
13.6.1	Preparation of USB Communication Cable and Console Software	13-14
13.6.2	Connecting to Host Computer	13-14
13.6.3	Specification Setting	13-18
13.7	Operation	13-27
13.7.1	Communication Procedure	13-27
13.7.2	Handshake between Control Module QTC1-4P and PLC	13-28
13.7.3	PLC Communication Data Map	13-30
13.7.4	Data Exchange between Control Module QTC1-4 and P-PLC	13-38
13.7.5	Data Settings	13-39
14	CUnet Communication	14-1
14.1	Flow of Before Operation	14-2
14.2	Setting CUnet communication specifications	14-3
14.3	Mounting	14-6
14.4	Wiring	14-7
14.4.1	Wiring for Power Supply and Communication	14-7
14.4.2	Wiring for Input, Output and CT	14-9
14.4.3	Wiring Example of CUnet Communication Line	14-10
14.5	Global Memory (GM)	14-11
14.6	Software	14-11
14.7	Global Memory (GM) Map	14-12
14.8	Attached Function	14-13
15	Action Explanation	15-1
15.1	Control Action Explanation	15-1
15.1.1	2 DOF PID Control	15-2
15.1.2	Fast-PID Control	15-3
15.1.3	Slow-PID Control	15-3
15.1.4	ON-OFF Control	15-3
15.1.5	Gap-PID Control	15-3

15.1.6	PID Control Parameters.....	15-4
15.2	Standard Function	15-6
15.2.1	Control Range	15-6
15.2.2	Proportional band decimal point position selection.....	15-6
15.2.3	Integral/Derivative Decimal Point Position	15-6
15.2.4	MV Bias	15-6
15.2.5	Control action selection when input error.....	15-6
15.2.6	Output Minimum ON/OFF Time.....	15-7
15.2.7	Alarm Output	15-8
15.2.8	Loop Break Alarm.....	15-8
15.2.9	Set Value Ramp Functio.....	15-8
15.2.10	Power On Restore Action	15-9
15.2.11	Non-volatile IC Memory Data Save	15-9
15.2.12	Auto/Manual Control Switching.....	15-9
15.2.13	Sensor Correction Factor.....	15-10
15.2.14	Sensor Correction.....	15-10
15.2.15	Output Rate-of-Change Limit.....	15-11
15.2.16	Control Function	15-12
15.3	Extension function	15-17
15.3.1	Extension function selection	15-17
15.3.2	Output Gain – Bias Function.....	15-25
15.3.3	Input Math Function.....	15-26
15.3.4	Input Difference Selection.....	15-26
15.3.5	Combination of Functions	15-27
15.4	Attached Function	15-28
15.4.1	Power Failure Countermeasure.....	15-28
15.4.2	Self-Diagnosis	15-28
15.4.3	Automatic Cold Junction Temperature Compensation	15-28
15.4.4	PV Filter Time Constant.....	15-28
15.4.5	Moving average count	15-29
15.4.6	CH Enable/Disable	15-29
15.4.7	Overscale	15-29
15.4.8	Underscale	15-29
15.4.9	Sensor Error	15-29
15.4.10	Cold Junction Error	15-30
15.4.11	ADC Error.....	15-30
15.4.12	Warm-up indication.....	15-30
15.4.13	Contact Switching Total Number of Times.....	15-30
15.4.14	Total Energizing Time.....	15-31
15.4.15	Heater Accumulated Energizing Time	15-31
15.4.16	Error History	15-31
15.5	Operation Diagram	15-32
15.5.1	Control Output Operation Diagram	15-32
15.5.2	Control Output ON/OFF Operation Diagram.....	15-33
15.5.3	Alarm Operation Diagram	15-34
15.5.4	Heater Burnout Alarm Operation Diagram.....	15-36
15.5.5	Heating/Cooling Control Operation Diagram	15-37
15.5.6	Heating/Cooling Control Operation Diagram (When Setting Dead Band).....	15-38
15.5.7	Heating/Cooling Control Operation Diagram (When Setting Overlap Band).....	15-39

16	Maintenance and Inspection	16-1
16.1	Maintenance.....	16-1
16.2	Inspection	16-3
17	Specifications	17-1
17.1	Standard Specifications.....	17-1
17.2	Optional Specifications.....	17-22
18	Troubleshooting.....	18-1
18.1	Communication (Host Communication).....	18-1
18.2	Communication (CUnet Communication).....	18-2
18.3	PV Reading Value	18-2
18.4	Status Flag 1	18-3
18.5	Status Flag 2	18-3
18.6	Control.....	18-4
18.7	Loop Break Alarm.....	18-5
18.8	Heater Burnout Alarm.....	18-5

1 Overview

1.1 Overview of Control Module QTC1-4

This instrument is a control module that can be 4 channels controlled.

A multi-point control system can be configured with the control module alone, or via a host computer or PLC.

A maximum of 16 instruments can be connected via BUS, and a maximum of 64 points can be controlled.

One block connected to BUS is called "1 unit".

In addition, a maximum of 16 units can be connected using the communication expansion module QMC1 and a maximum of 1024 points can be controlled.

Connector type

QTC1-40C-□□□□□□□□-0□

No options

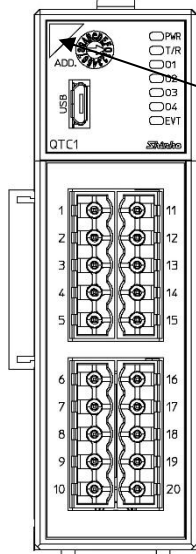

(Fig. 1.2-5)

QTC1-40C-□□□□□□□□-2□ , QTC1-40C-□□□□□□□□-A□

With heater burnout alarm option

triangle mark

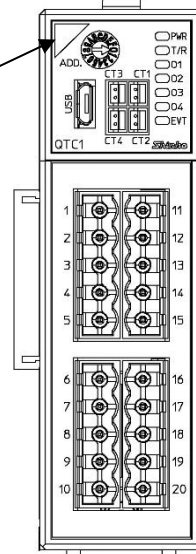

(Fig. 1.2-6)

QTC1-4□C-□□□□□□□□-0□

With power supply / communication options

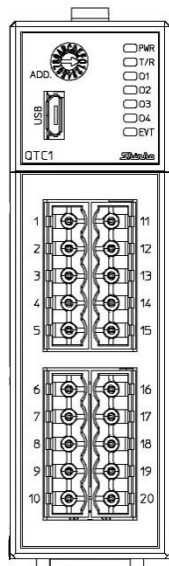

(Fig. 1.2-7)

QTC1-4□C-□□□□□□□□-2□ , QTC1-4□C-□□□□□□□□-A□

With power supply / communication option and heater burnout alarm option

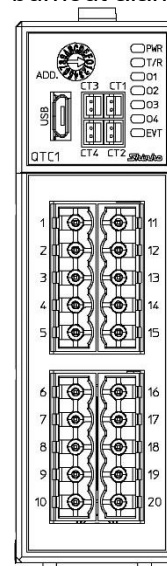

(Fig. 1.2-8)

1.3 System Configuration

1.3.1 Using Control Module Alone

When using the control module alone, one control module QTC1-4P (with power supply / communication option) is required for connecting to the power line.

The second and subsequent power lines to the control module are BUS-connected by the connector. For the second and subsequent control modules, use the control module QTC1-40(no power supply / communication option).

Maximum of 16 control modules can be connected.

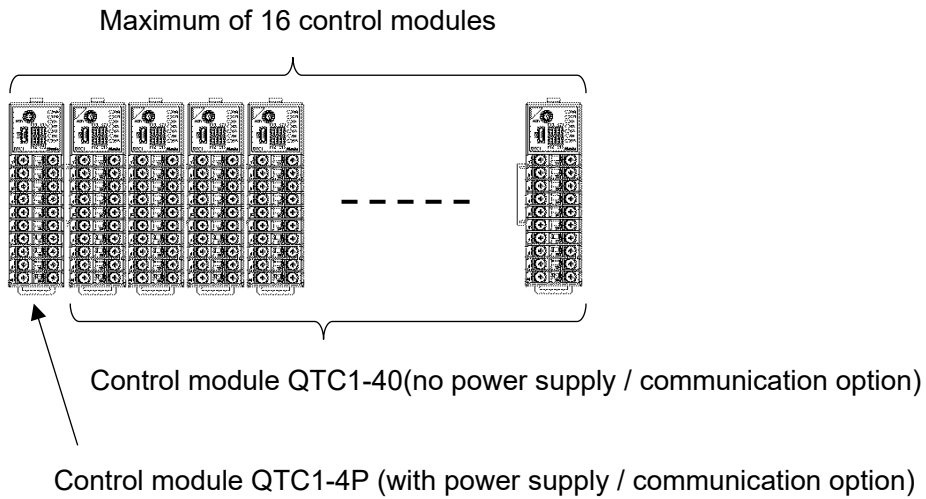

(Fig. 1.3.1-1)

1.3.2 Connecting to Host Computer

When connecting to the host computer, one control module QTC1-4P (with power supply / communication option) is required for host communication.

The second and subsequent power lines to the control module are BUS-connected by the connector. For the second and subsequent control modules, use the control module QTC1-40(no power supply / communication option).

Maximum of 16 control modules can be connected.

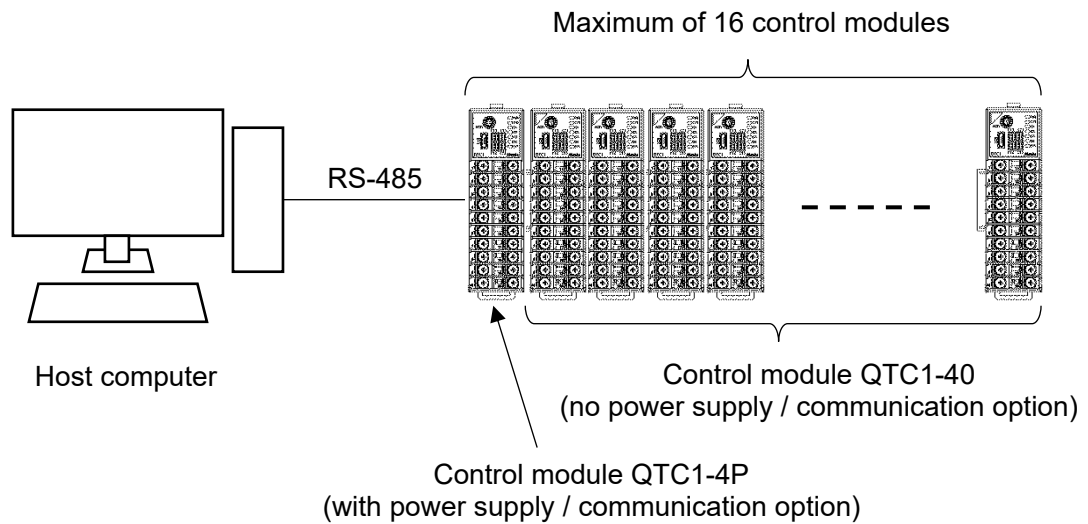

(Fig. 1.3.2-1)

A maximum of 16 units can be connected by connecting the communication expansion module QMC1-C□s.

Refer to communication expansion module QMC1-C□ instruction manual for detail.

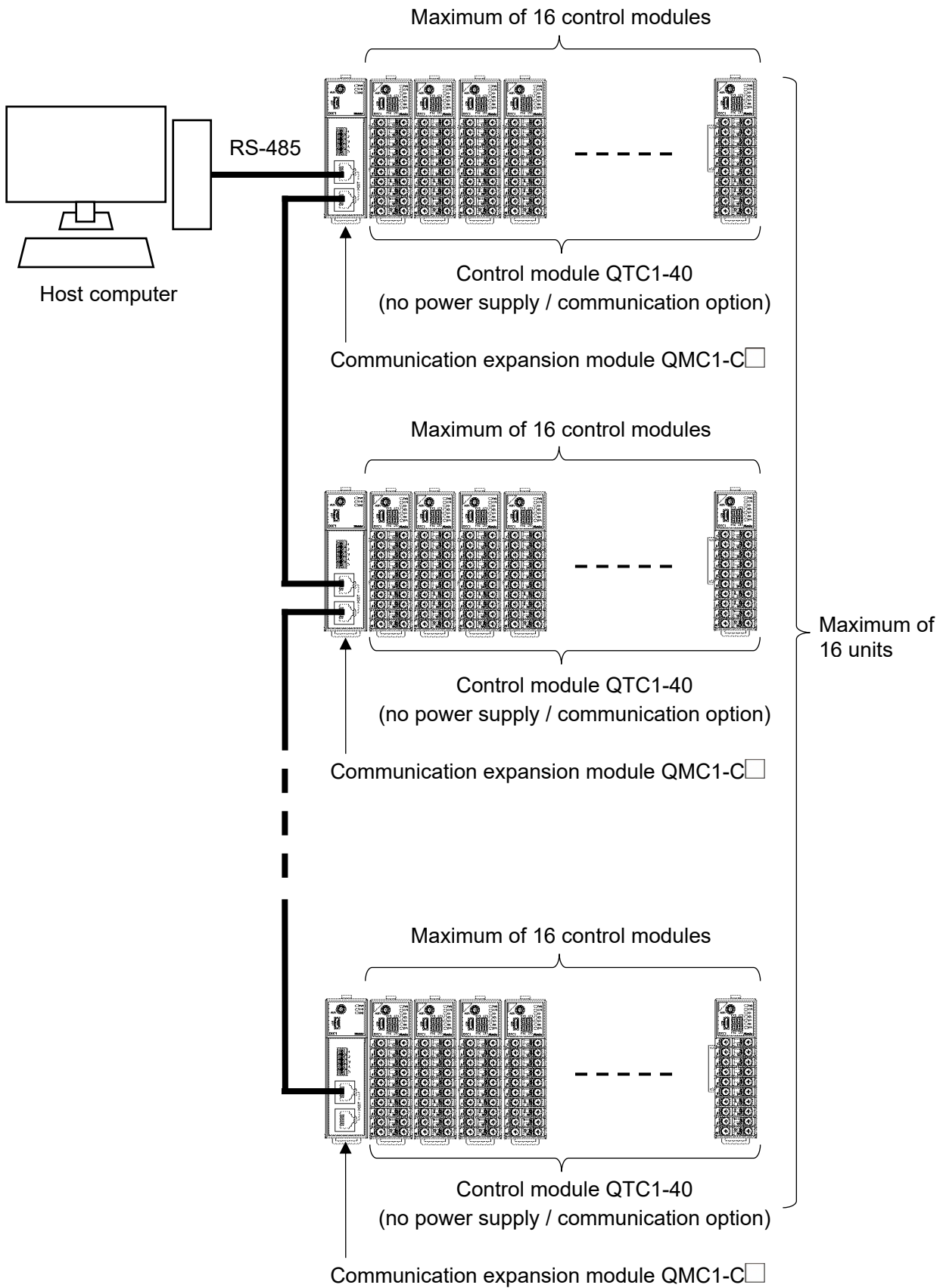

(Fig. 1.3.2-2)

1.3.3 Connecting to PLC

(1) When connecting to MELSEC Q, QnA series by Mitsubishi Electric Corporation

When connecting to the MELSEC Q, QnA series by Mitsubishi Electric Corporation, one control module QTC1-4P (with power supply / communication option) is required for host communication. Use the SIF function (Smart InterFace, programless communication function) (P.13-1 to P.13-36). The second and subsequent power lines to the control module are BUS-connected by the connector.

For the second and subsequent control modules, use the control module QTC1-40(no power supply / communication option).

Maximum of 16 control modules can be connected.

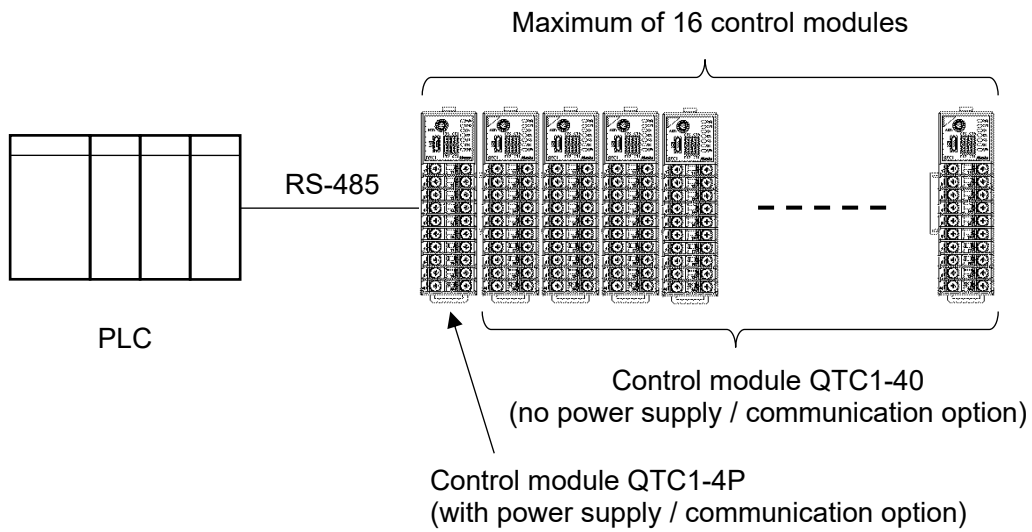

(Fig. 1.3.3-1)

- (2) When connecting to PLC by Mitsubishi Electric Corporation, PLC by OMRON Corporation and PLC by KEYENCE CORPORATION

When connecting to the PLC by Mitsubishi Electric Corporation, PLC by OMRON Corporation (*) and PLC by KEYENCE CORPORATION, one communication expansion module QMC1-C□ is required for host communication per unit.

The power lines to the control module are BUS-connected by the connector.

Use the control module QTC1-40(no power supply / communication option).

Maximum of 16 control modules can be connected.

- (*): When connecting to an OMRON PLC with the SIF function of communication expansion module QMC1-C□, the RS-485 communication type cannot be used.
Only RS-422A communication type can be connected.

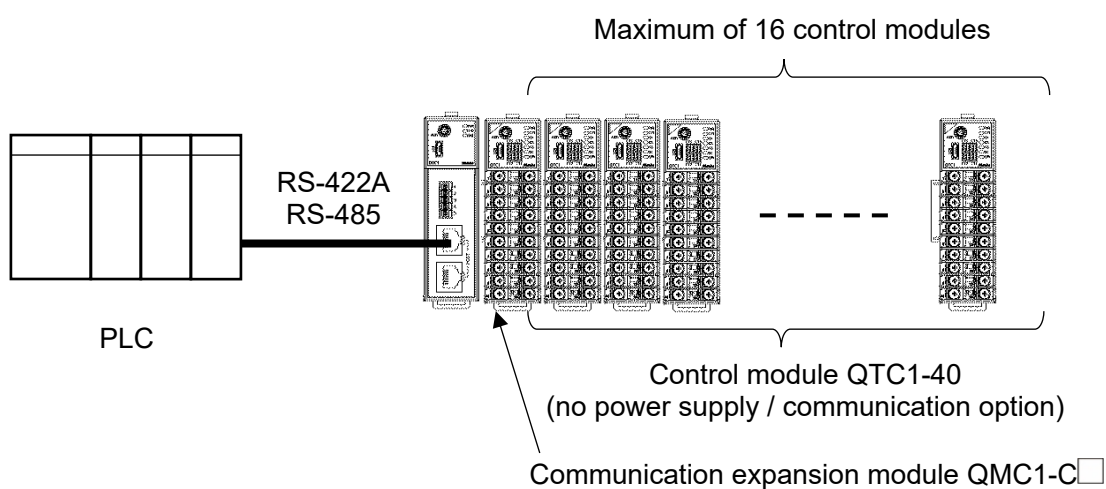

(Fig. 1.3.3-2)

A maximum of 16 units can be connected by connecting the communication expansion module QMC1-C□s.

Refer to communication expansion module QMC1-C□ instruction manual for detail.

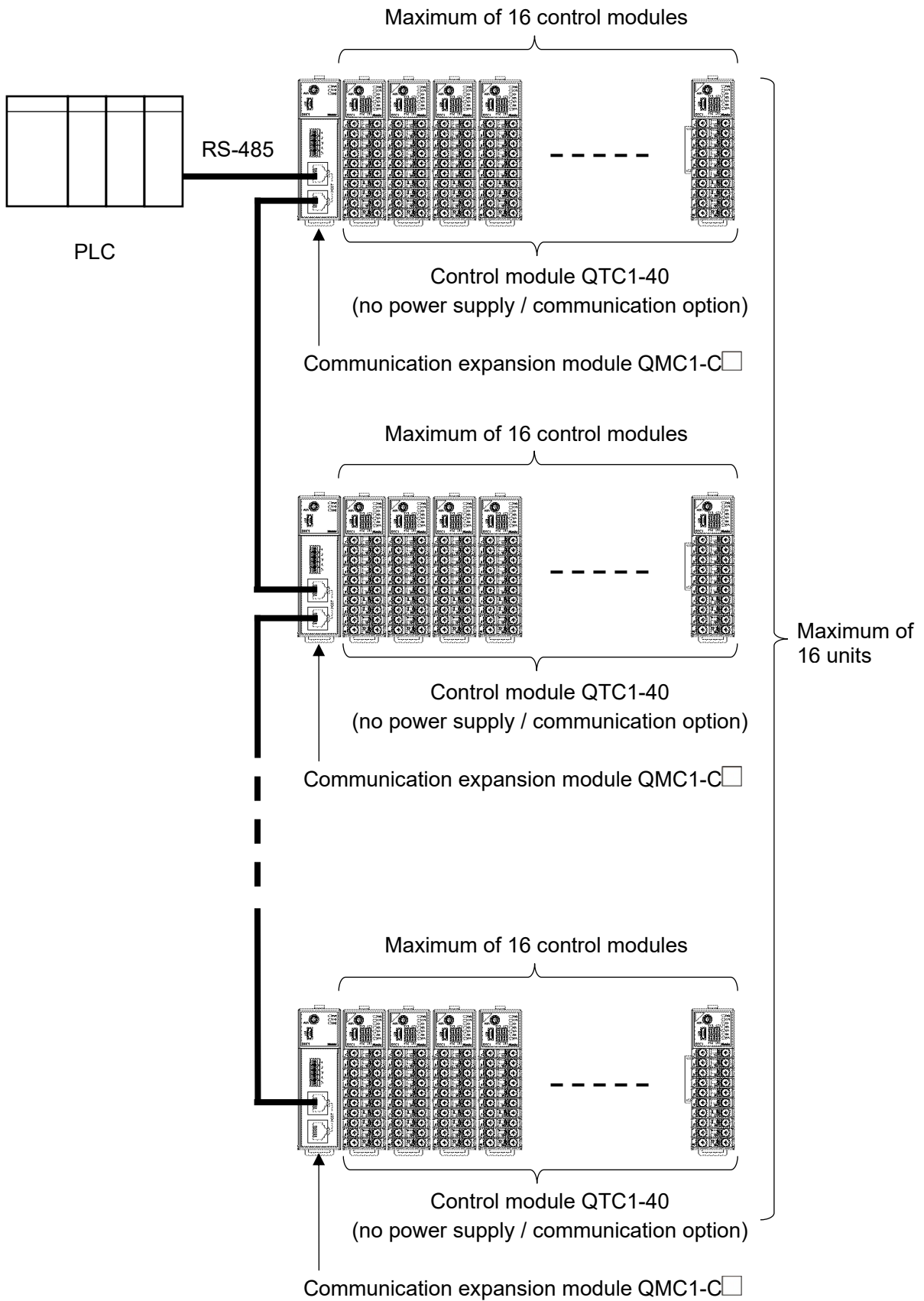

(Fig. 1.3.3-3)

1.3.4 Connecting to CUnet

When connecting to the CUnet, control module QTC1-4C (with power supply / CUnet communication option) is required.

Maximum of 64 control modules can be connected.

Configuration example of host computer (master board) and QTC1-4C

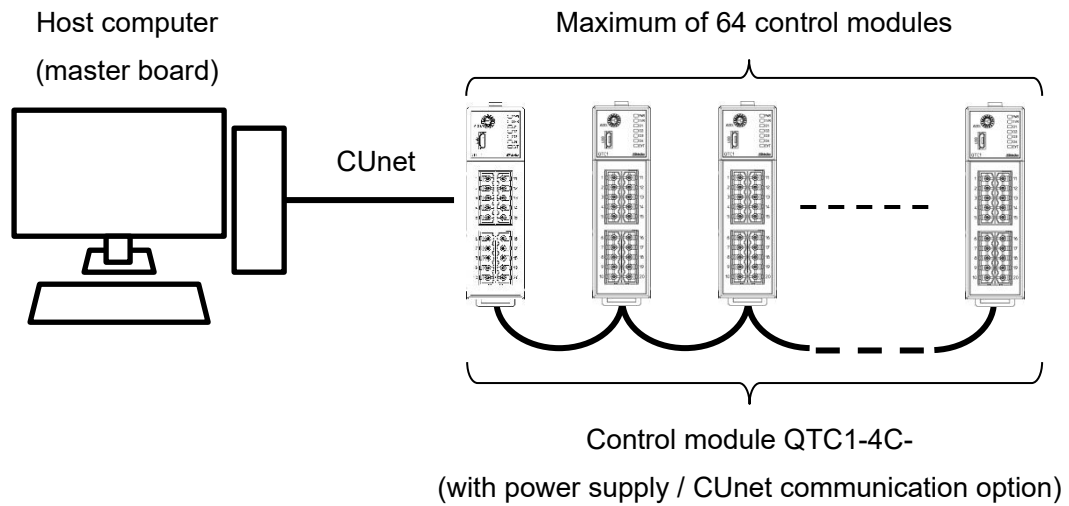

(Fig. 1.3.4-1)

1.4 Parameter Passing

1.4.1 Using the Control Module QTC1-4P (with power supply / communication option)

When the control module QTC1-4P (with power supply / communication option) is used, the parameter passing is as shown below.

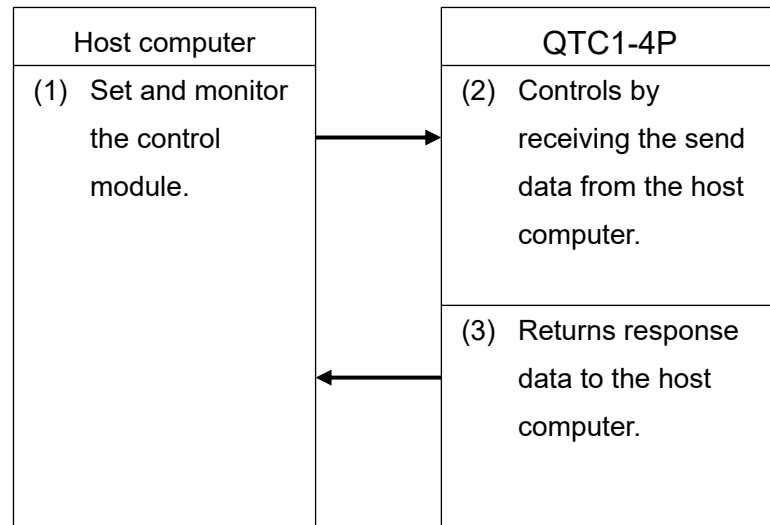

(Fig. 1.4.1-1)

1.4.2 Using the Communication Expansion Module QMC1-C□

When the communication expansion module QMC1-C□ is used, the parameter passing is as shown below.

Refer to the communication expansion module QMC1-C□ instruction manual for detail.

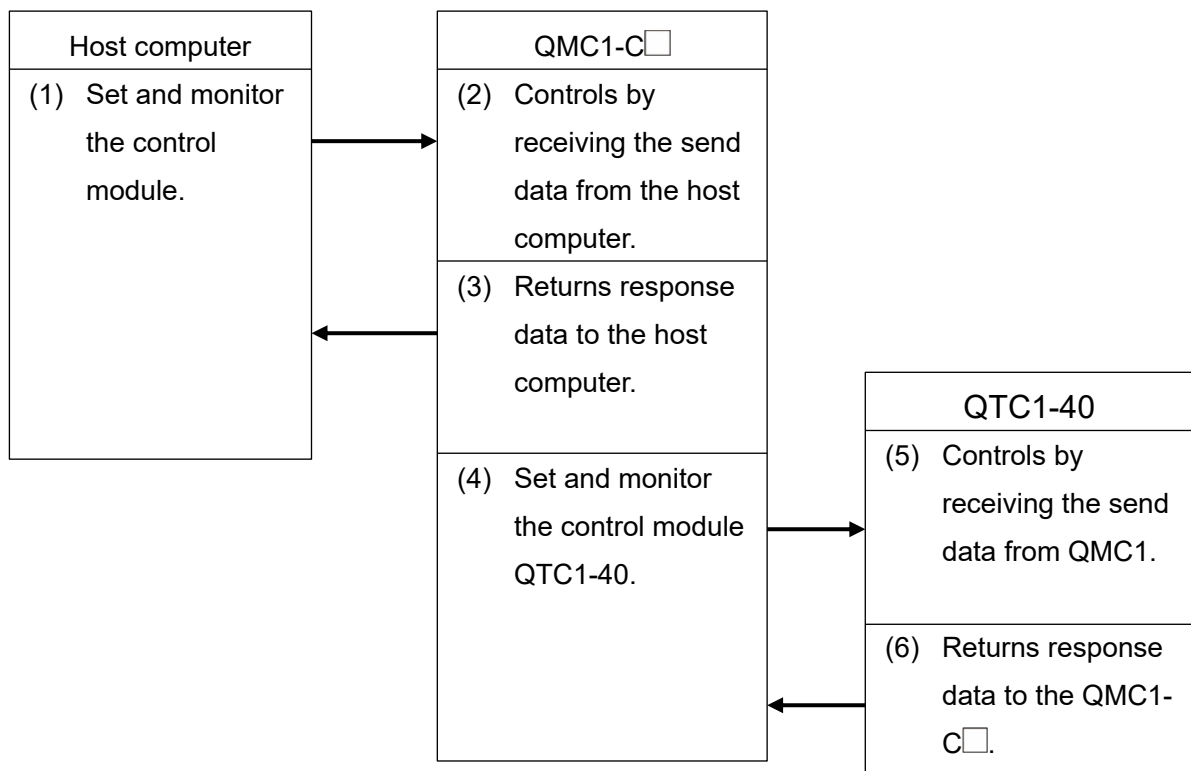

(Fig. 1.4.2-1)

2 Model

2.1 Model

QTC1-4		<input type="checkbox"/>	<input type="checkbox"/>	<input type="checkbox"/>	<input type="checkbox"/>	<input type="checkbox"/>	<input type="checkbox"/>	<input type="checkbox"/>	<input type="checkbox"/>	<input type="checkbox"/>	<input type="checkbox"/>	<input type="checkbox"/>			
Power supply / communication option	0												No option		
	P												With power supply / communication option		
	C												With power supply / CUnet communication option		
Wiring type	T												Terminal block type		
	C												Connector type		
CH1 Control output		<input type="checkbox"/>											Refer to output code table		
CH2 Control output			<input type="checkbox"/>												
CH3 Control output				<input type="checkbox"/>											
CH4 Control output					<input type="checkbox"/>										
CH1 Input								<input type="checkbox"/>					Refer to input code table (2-2)		
CH2 Input									<input type="checkbox"/>						
CH3 Input										<input type="checkbox"/>					
CH4 Input											<input type="checkbox"/>				
Heater burnout alarm option(*1)												-0	No option		
													-2	CT 4 points 20 A (*2)	
														-A	CT 4 points 100 A (*2)
Event input/output option													0	No option	
														1	Event input (4 points) (*3)
														2	Event output (4 points) (*3)

(*1): Cannot be added to DC current output type or DC voltage output type.

(*2): CT and connector harness are sold separately.

(*3): Connector harness is sold separately.

Output code table

Output code	Output type
R	Relay contact output
S	Non-contact voltage output (For SSR drive)
A	Direct current output 4 to 20 mA DC
0	Direct current output 0 to 20 mA DC
V	DC voltage output 0 to 1 V DC
1	DC voltage output 0 to 5 V DC
2	DC voltage output 1 to 5 V DC
3	DC voltage output 0 to 10 V DC
C	Open collector output

Input code table

Input code	Input type		Range
M	Thermocouple input	K	-200 to 1370°C
		K	-200.0 to 400.0°C
		J	-200 to 1000°C
		R	0 to 1760°C
		S	0 to 1760°C
		B	0 to 1820°C
		E	-200 to 800°C
		T	-200.0 to 400.0°C
		N	-200 to 1300°C
		PL- II	0 to 1390°C
		C (W/Re5-26)	0 to 2315°C
		K	-328 to 2498°F
		K	-328.0 to 752.0°F
		J	-328 to 1832°F
		R	32 to 3200°F
		S	32 to 3200°F
		B	32 to 3308°F
		E	-328 to 1472°F
		T	-328.0 to 752.0°F
		N	-328 to 2372°F
	PL- II	32 to 2534°F	
	C (W/Re5-26)	32 to 4199°F	
	RTD input	Pt100	-200.0 to 850.0°C
		Pt100	-328.0 to 1562.0°F
	DC voltage input	0 to 1 V DC	-32768 to 32767
	Direct current input	4 to 20 mA DC (Externally mounted shunt resistor)	-32768 to 32767
		0 to 20 mA DC (Externally mounted shunt resistor)	-32768 to 32767
A	Direct current input	4 to 20 mA DC (Built-in shunt resistor)	-32768 to 32767
		0 to 20 mA DC (Built-in shunt resistor)	-32768 to 32767
V	DC voltage input	0 to 5 V DC	-32768 to 32767
		1 to 5 V DC	-32768 to 32767
		0 to 10 V DC	-32768 to 32767

2.2 How to Read the Model Label

The model label is attached to the right side of this instrument.

Terminal block type

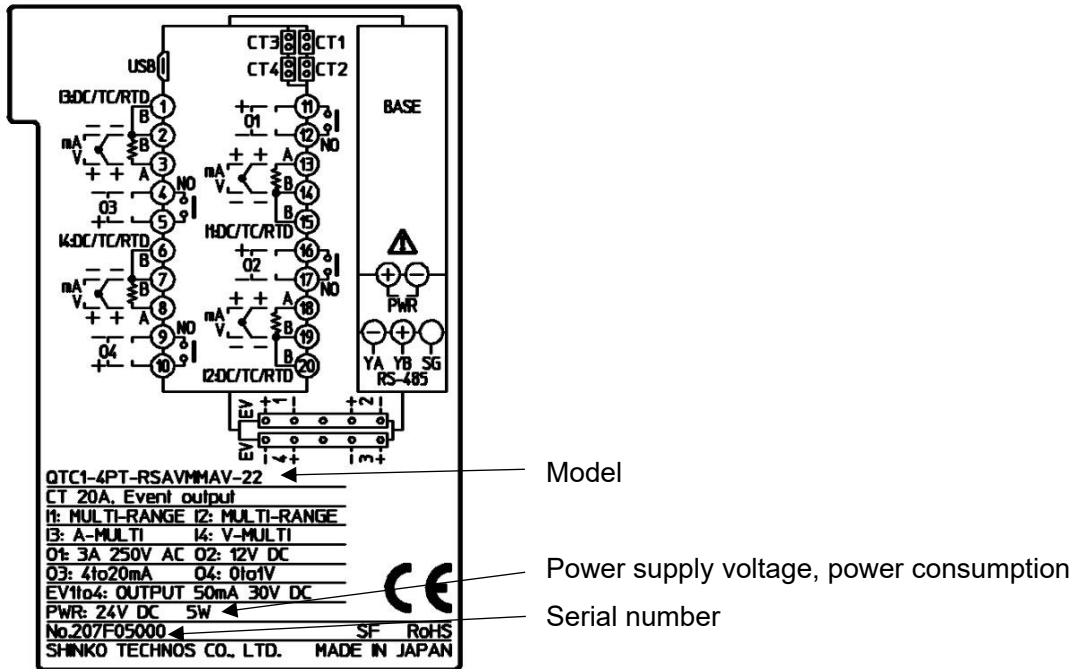

(Fig. 2.2-1)

Connector type

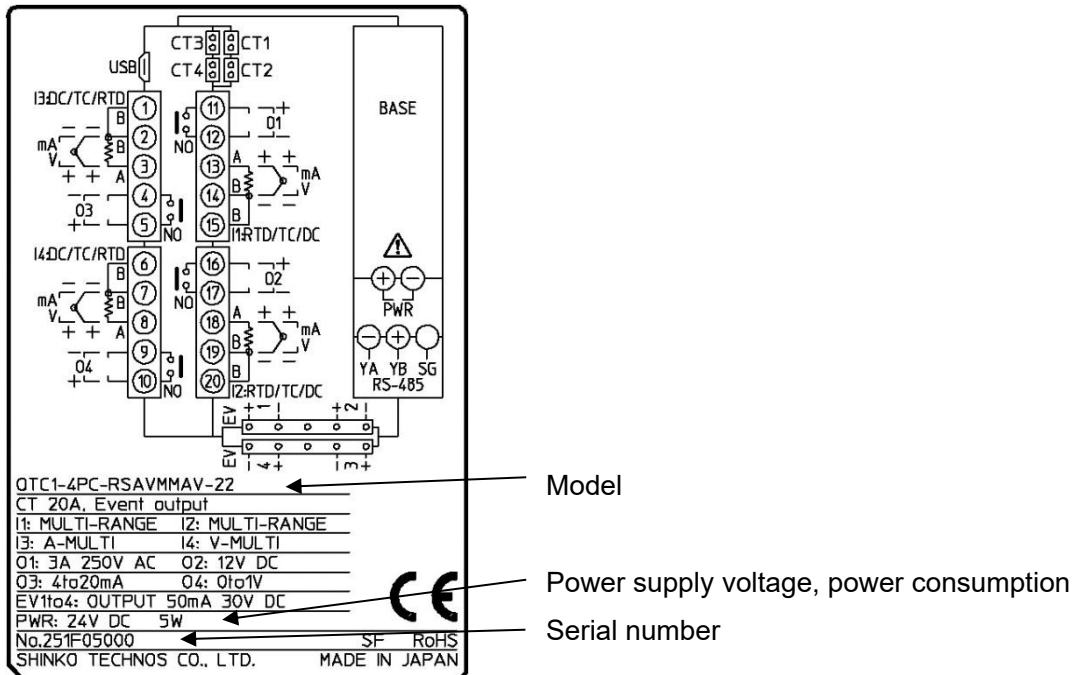

(Fig. 2.2-2)

3 Name and Functions

3.1 Control Module QTC1-4

Terminal block type

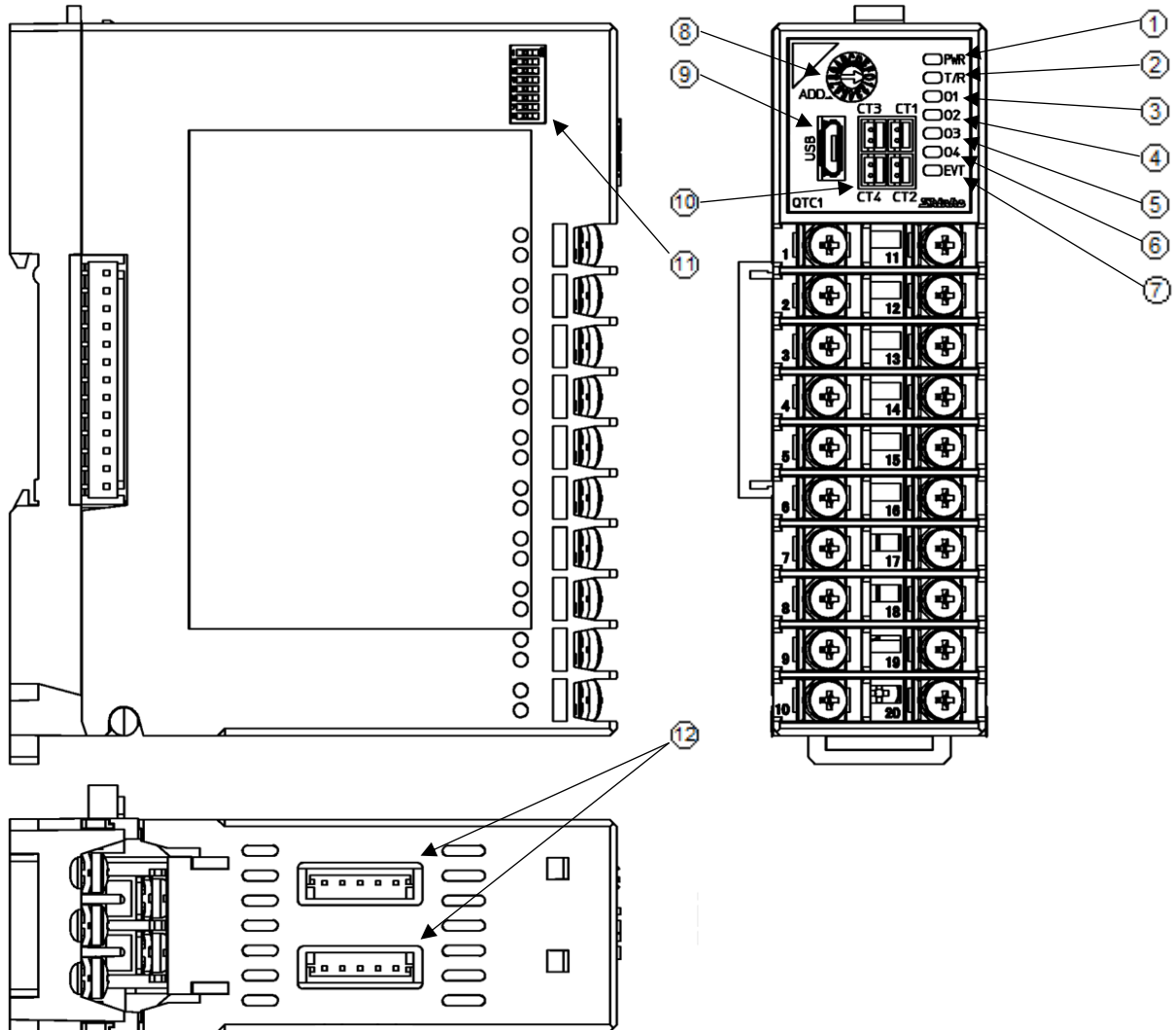

(Fig. 3.1-1)

Connector type

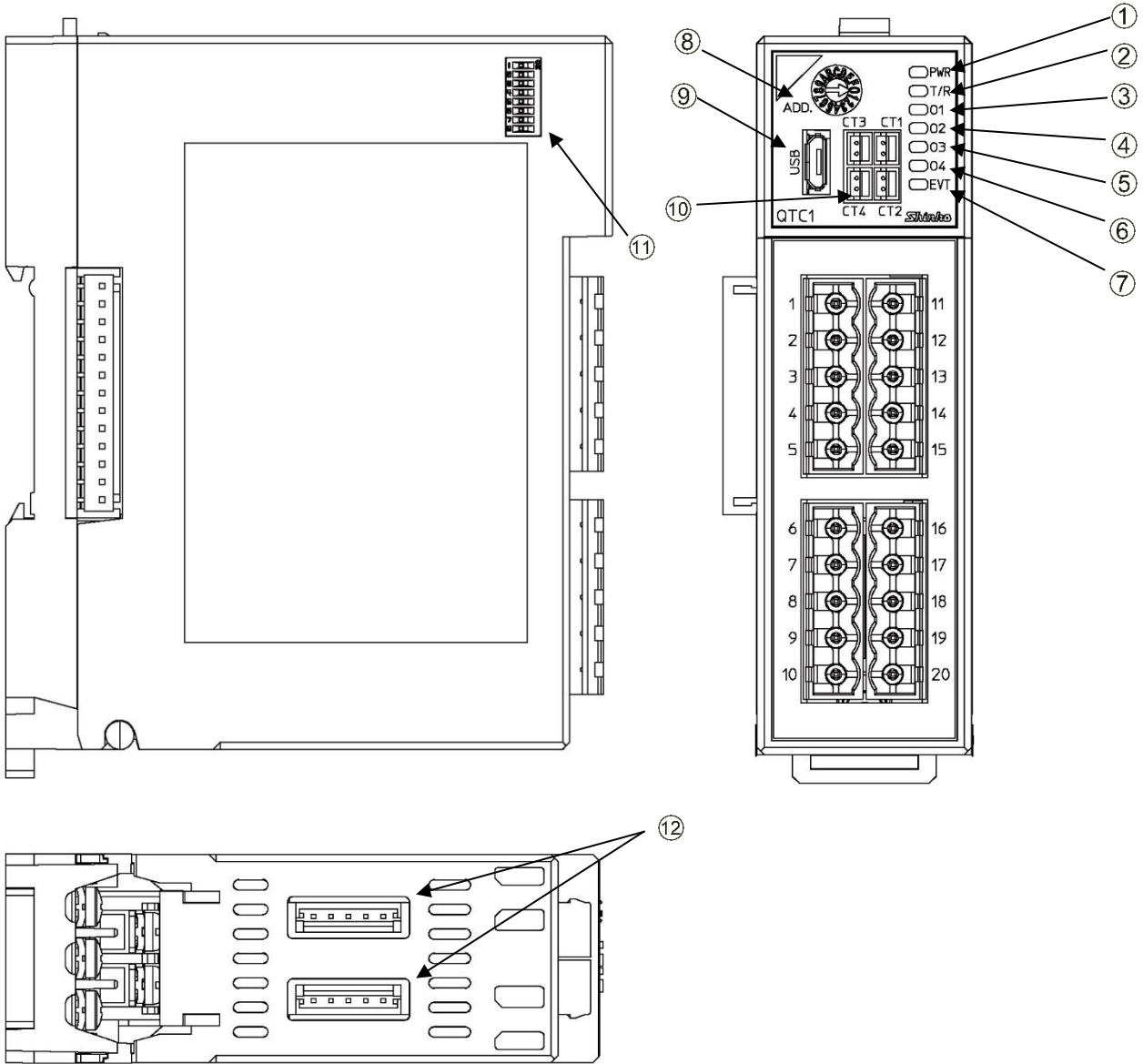

(Fig. 3.1-2)

Operation indicator

No.	Symbol (color)	Name and Function
①	PWR (Green)	<p>Power indicator</p> <ul style="list-style-type: none"> • Lights off (always): No power supply to the instrumen • Lights up (always): Power supply to the instrumen • Flashing for 500 ms (3 seconds): Warming up the instrument • Flashing for 500 ms (always): Internal failure of the instrument [When non-volatile IC memory error or ADC (internal circuit) error]
②	T/R (Yellow)	<p>Communication indicator</p> <ul style="list-style-type: none"> • Lights off (always): Communication error (no response) or USB communication • Flashing (slow): Communication error (reception error) • Flashing (fast): Communication is normal
③	O1 (Green)	<p>CH1 control output indicator</p> <ul style="list-style-type: none"> • Lights off: CH1 control output is OFF or control is prohibited • Lights up: CH1 control output is ON (other than direct current output and DC voltage output) • Flashing: CH1 control output is ON (Dorect current output, DC voltage output)
④	O2 (Green)	<p>CH2 control output indicator</p> <ul style="list-style-type: none"> • Lights off: CH2 control output is OFF or control is prohibited • Lights up: CH2 control output is ON (other than direct current output and DC voltage output) • Flashing: CH2 control output is ON (Direct current output, DC voltage output)
⑤	O3 (Green)	<p>CH3 control output indicator</p> <ul style="list-style-type: none"> • Lights off: CH3 control output is OFF or control is prohibited • Lights up: CH3 control output is ON (other than DC current output and DC voltage output) • Flashing: CH3 control output is ON (DC current output, DC voltage output)
⑥	O4 (Green)	<p>CH4 control output indicator</p> <ul style="list-style-type: none"> • Lights off: CH4 control output is OFF or control is prohibited • Lights up: CH4 control output is ON (other than DC current output and DC voltage output) • Flashing: CH4 control output is ON (DC current output, DC voltage output)
⑦	EVT (Red)	<p>Event indicator</p> <ul style="list-style-type: none"> • Lights off (always): No alarm or abnormality • Lights up (always): Alarm, loop abnormality alarm or heater burnout alarm (option) is activated • Flashing for 500 ms: Sensor error (overscale, underscale) • Flashing for 250 ms: Sensor error (input disconnection) or power is supplied from the computer by USB bus power

Switch and connector

No.	Symbol	Name and Function
⑧	ADD.	Module address selection rotary switch Rotary switch for module address selection. The module address is the value of the selected rotary switch plus one.
⑨	USB	Console communication connector Connector for console communication tool cable.
⑩	CT1	CH1 CT input connector Connector for heater burnout alarm CT input of CH1.
	CT2	CH2 CT input connector Connector for heater burnout alarm CT input of CH2.
	CT3	CH3 CT input connector Connector for heater burnout alarm CT input of CH3.
	CT4	CH4 CT input connector Connector for heater burnout alarm CT input of CH4.
⑪		Communication specification selection dip switch DIP switch for selecting communication specifications. Select the communication specifications such as communication speed, data bit, parity, stop bit and communication protocol.
⑫		Event input/output connector Connector for event input or event output. Operation is selected by event input assignment selection or event output assignment selection.

4 Procedure Before Starting Operation

The procedure up to the start of operation when connecting to a host computer is shown below.

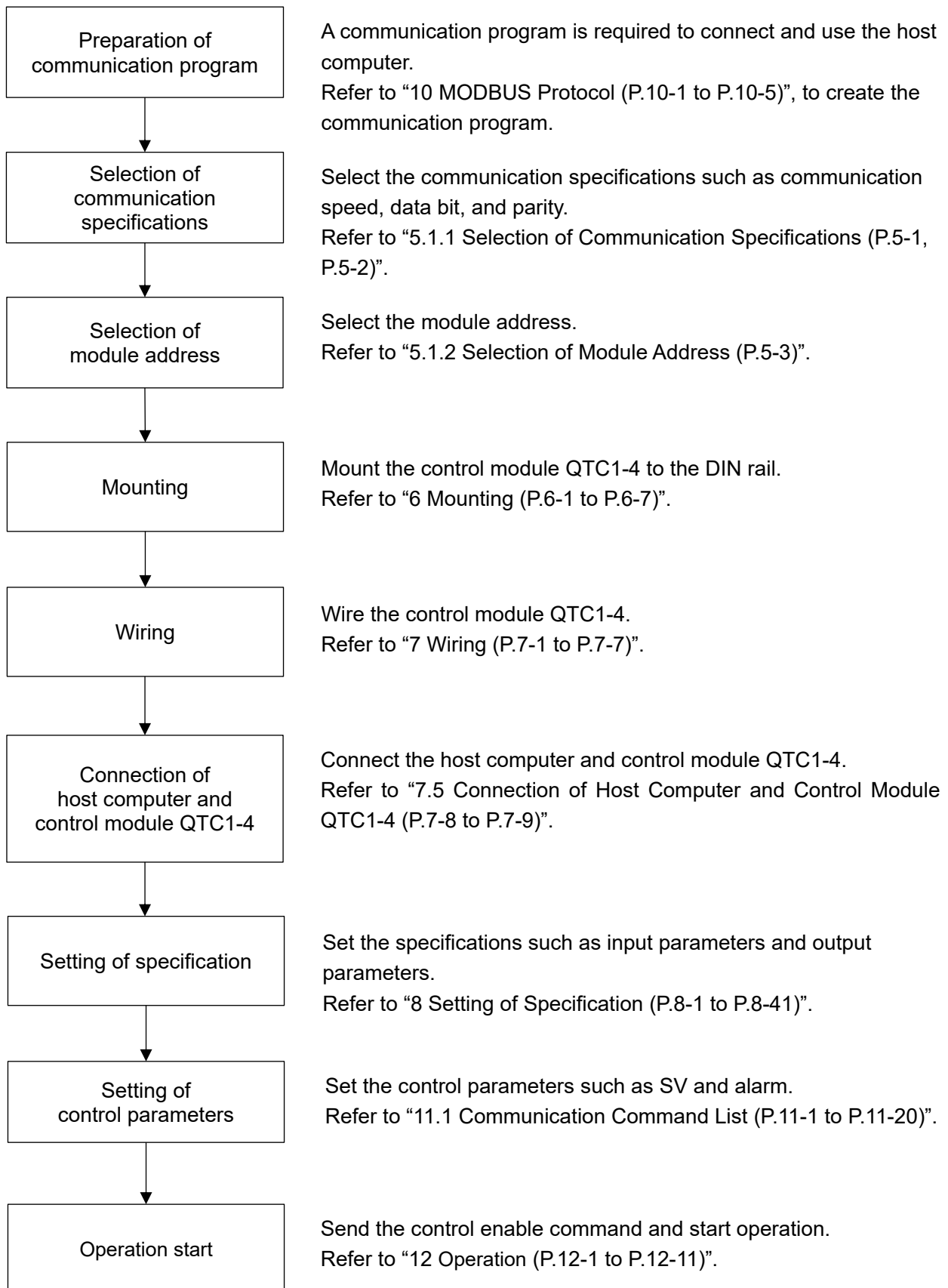

(Fig. 4-1)

5 Communication Parameter Setting

5.1 Communication Parameter Setting

5.1.1 Selection of Communication Specifications



Caution

When connecting to the communication expansion module QMC1-C□, the communication specification selection is not required.

Use it in the factory default (all OFF).

Use the communication specification selection dip switch on the left side of the instrument to select communication specifications.

Terminal block type

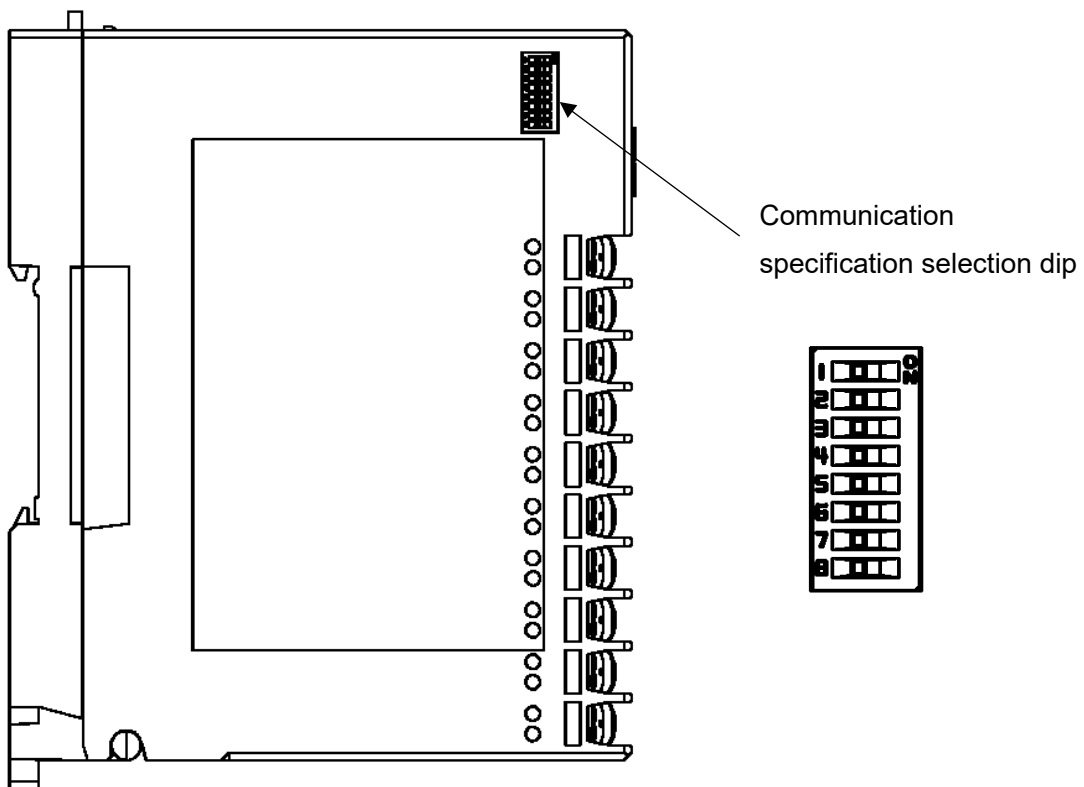

(Fig. 5.1.1-1)

Connector type

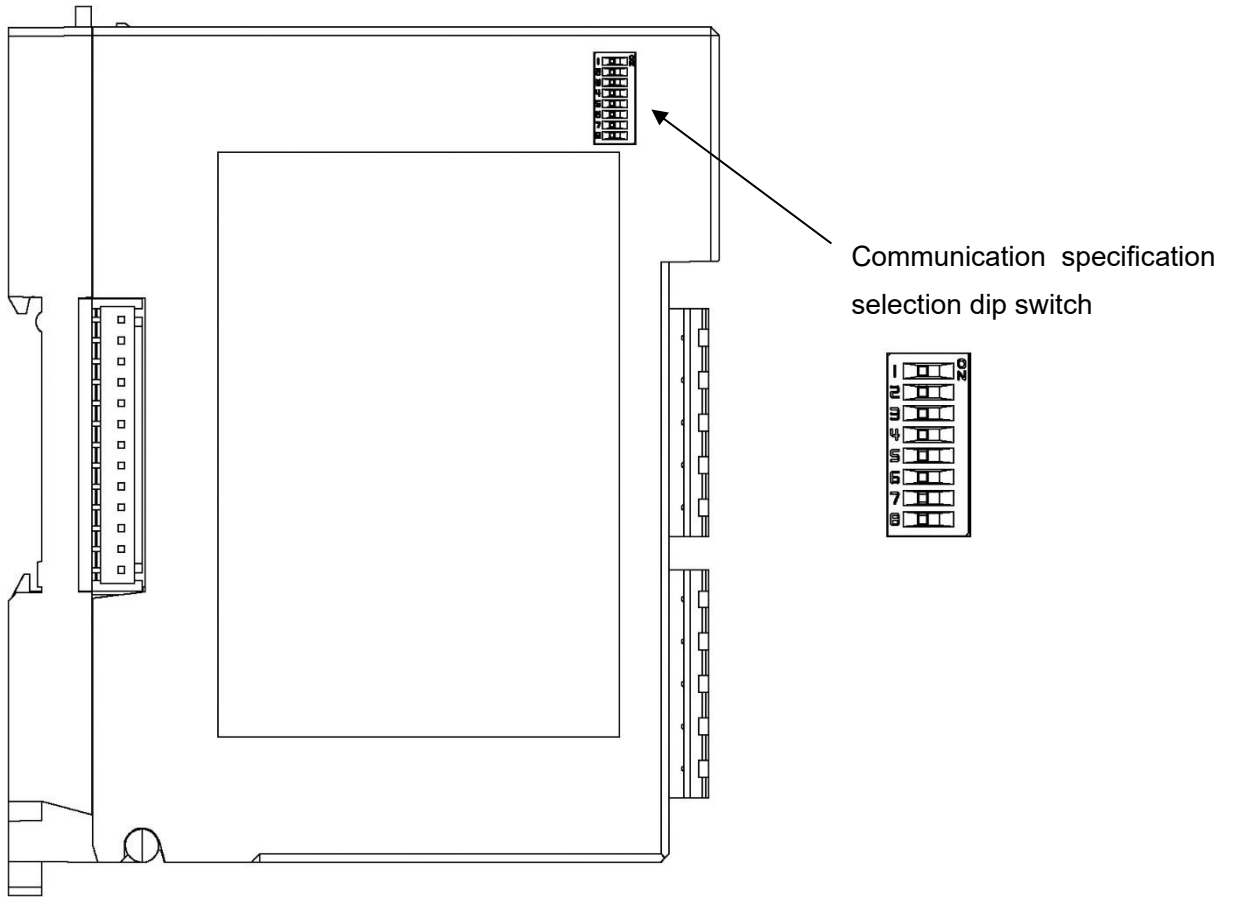

(Fig. 5.1.1-2)

Select the communication speed, data bit, parity, stop bit and communication protocol.

All are off when shipped from the factory.

- Communication speed: 57600 bps
- Data bit: 8 bits
- Parity: Even
- Stop bit: 1 bit
- Communication protocol: MODBUS specification

(1) Selection of communication speed

Communication specification selection dip switch		Communication speed
1	2	
OFF	OFF	57600 bps
ON	OFF	38400 bps
OFF	ON	19200 bps
ON	ON	9600 bps

(2) Selection of data bit, parity and stop bit

Communication specification selection dip switch			Data bit, parity and stop bit
3	4	5	
OFF	OFF	OFF	8 bits, Even, 1 bit
ON	OFF	OFF	8 bits, Even, 2 bits
OFF	ON	OFF	8 bits, Odd, 1 bit
ON	ON	OFF	8 bits, Odd, 2 bits
OFF	OFF	ON	8 bits, None, 1 bit
ON	OFF	ON	8 bits, None, 2 bits

(3) Selection of communication protocol

Communication specification selection dip switch	Communication protocol
6 (*)	
OFF	MODBUS specification
ON	SIF specification

(*): Valid for QTC1-4P (with power supply / host communication function)

Dip switches No.7 and No.8 does not use. Leave it OFF.

5.1.2 Selection of Module Address

Caution

When SIF specification is selected in "Selection of communication protocol (P. 5-2)" or when auto balance control function is selected in " Extension function selection P.8-32)", select module addresses from 1 to consecutive numbers.

If select MODBUS specification, select any number from 0 to F (1 to 16).

The module address is selected with the rotary switch.

Terminal block type

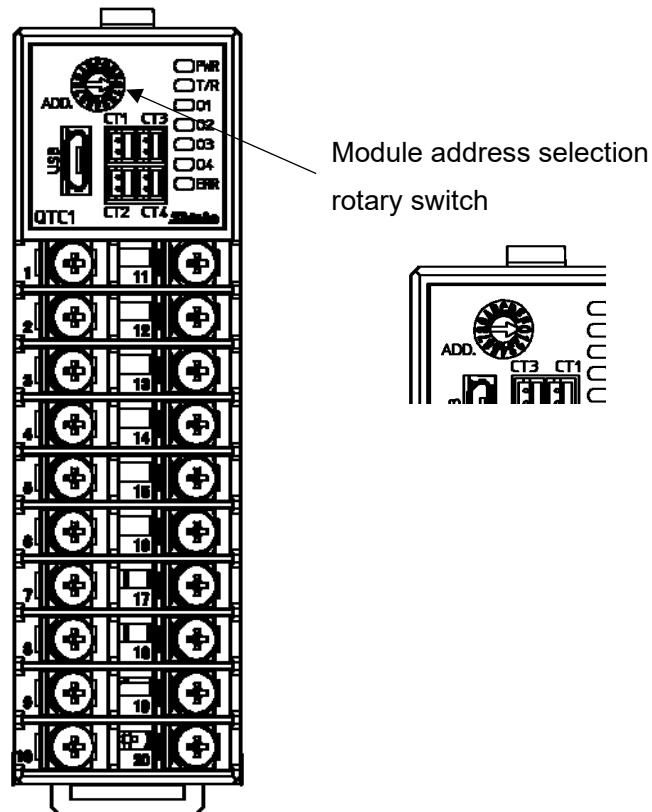

(Fig. 5.1.2-1)

Connector type

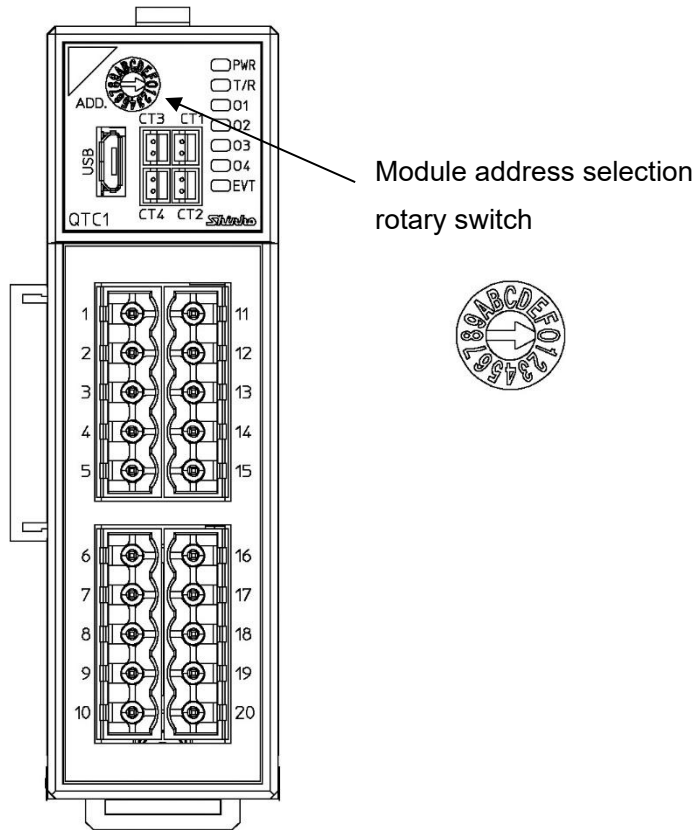

(Fig. 5.1.2-2)

Use a small flat blade screwdriver to select the module address.

The value obtained by adding 1 to the value of the selected rotary switch becomes the module address.

Module address: 0 to F (1 to 16)

Rotary switch	0	1		9	A	B		F
Module address	1	2		10	11	12		16

5.1.3 Setting of CUnet communication specification

The CUnet communication specifications are set by the dip switches (SW10, SW11) on the base part.

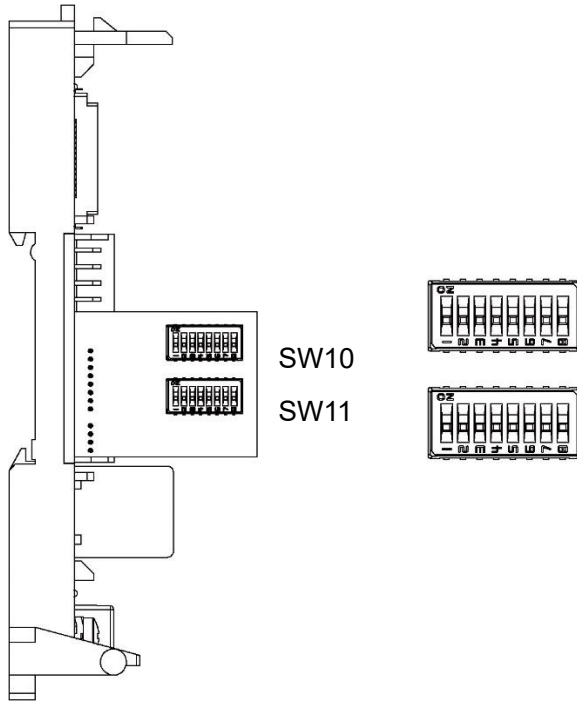

(Fig. 5.1.3-1)

SW	No.	State		Factory default
SW10	1	Station address setting	Bit0 ON: Enable, OFF: Disable	Disable
	2		Bit1 ON: Enable, OFF: Disable	Disable
	3		Bit2 ON: Enable, OFF: Disable	Disable
	4		Bit3 ON: Enable, OFF: Disable	Disable
	5		Bit4 ON: Enable, OFF: Disable	Disable
	6		Bit5 ON: Enable, OFF: Disable	Disable
	7	Communication speed setting	7:OFF 8:OFF 12Mbps 7:ON 8:OFF 6Mbps	12 Mbps
	8		7:OFF 8:ON 3Mbps 7:ON 8:ON Disable (12 Mbps)	
SW11	1	Master address setting	Bit0 ON: Enable, OFF: Disable	Disable
	2		Bit1 ON: Enable, OFF: Disable	Disable
	3		Bit2 ON: Enable, OFF: Disable	Disable
	4		Bit3 ON: Enable, OFF: Disable	Disable
	5		Bit4 ON: Enable, OFF: Disable	Disable
	6		Bit5 ON: Enable, OFF: Disable	Disable
	7	Number of occupied (OWN) items selection(*)	7: OFF 8: OFF 1 item 7: ON 8: OFF 2 items	1 item
	8		7: OFF 8: ON 3 items 7: ON 8: ON 4 items	

(*): The following items are allocated to global memory for each module.

Number of occupied (OWN) items	QTC1-4	
	DI item	DO item
1	PV: 03E8-03EB	Manual control MV: 0014-0017
2	Status flag 1: 03F4-03F7	
3	MV: 03EC-03EF	
4		

The cells with diagonal lines are invalid (no area is allocated in global memory) because they have no allocation.

Refer to "11. Communication Command List" for details.

6 Mounting

Caution

- When mounting or removing this instrument, be sure to turn off the power supply to this instrument.
- Mount the DIN rail horizontally.
- This instrument fits the following DIN rails.
Top hat rail TH35 JIS C 2812-1988

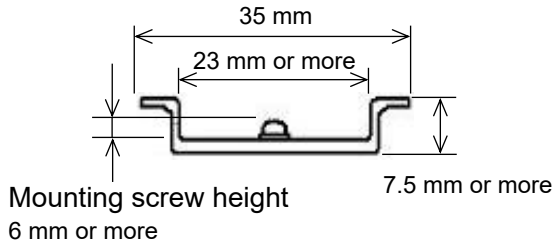

Width: 35 mm
Height: 7.5 mm or more
Groove width: 23 mm or more
DIN rail mounting screw height:
6 mm or more
(For DIN rail height 7.5 mm)

(Fig. 6-1)

- If this instrument is mounted in a position susceptible to vibration or shock, mount commercially available end plate at both ends of the instrument.
- When installing, make sure that the orientation (upper and lower) of this instrument is correct.
- When mounting or removing this instrument on the DIN rail, it must be tilted slightly
Secure a space of 50 mm or more in the vertical direction of the instrument, considering the wiring space of the power supply/communication line and heat dissipation.

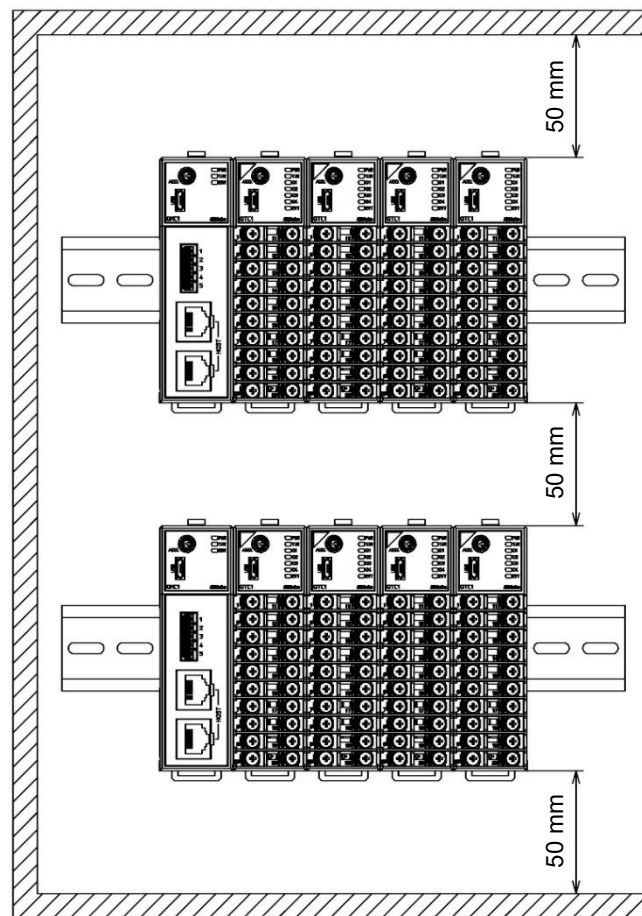

(Fig. 6-2)

6.1 Selection of Location

Ensure the mounting location corresponds to the following conditions:

- A minimum of dust, and an absence of corrosive gases
- No flammable, explosive gases
- No mechanical vibrations or shocks
- No exposure to direct sunlight, an ambient temperature of -10 to 50°C(14°F to 122°F) that does not change rapidly, and no icing
- An ambient non-condensing humidity of 35 to 85%RH
- No large capacity electromagnetic switches or cables through which large current is flowing
- No water, oil or chemicals or the vapors of these substances can come into direct contact with the unit.
- When installing this unit within a control panel, please note that ambient temperature of this unit – not the ambient temperature of the control panel – must not exceed 50°C (122°F). Otherwise the life of electronic components (especially electrolytic capacitor) may be shortened.
- * Avoid setting this instrument directly on or near flammable material even though the case of this instrument is made of flame-resistant resin.

6.2 External Dimensions (Scale: mm)

6.2.1 Control Module QTC1-4

Terminal block type

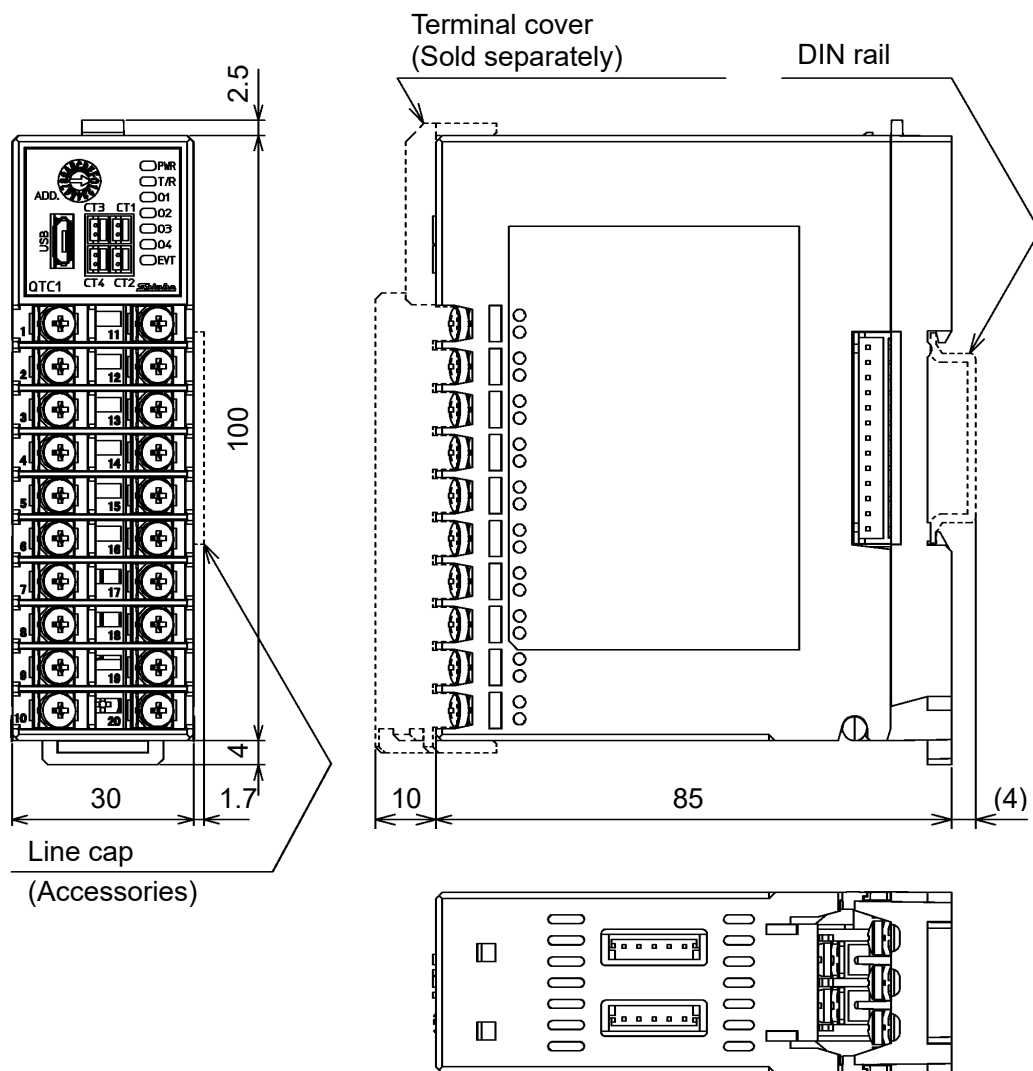

(Fig. 6.2.1-1)

Connector type

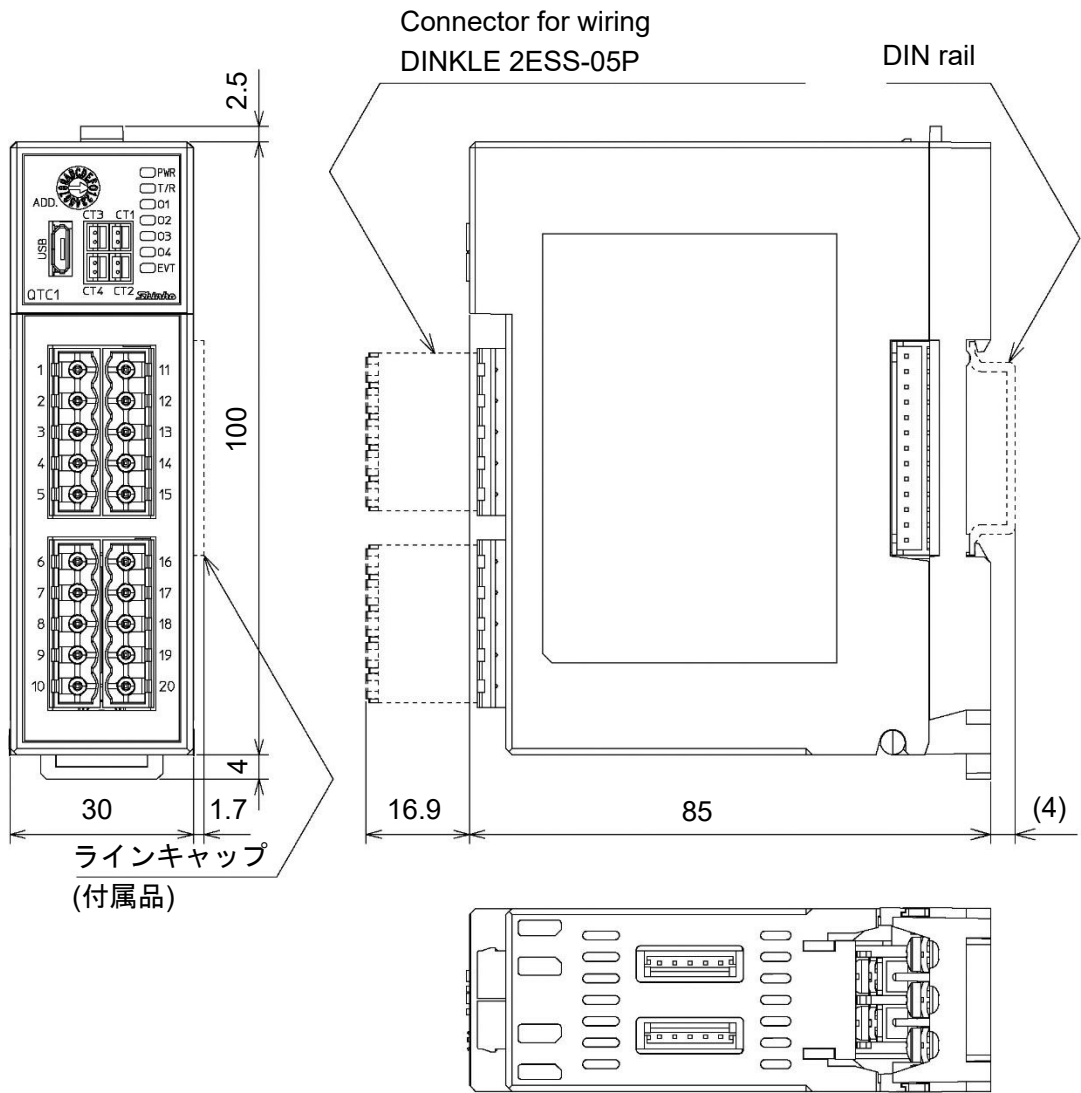

(Fig. 6.2.1-2)

6.2.2 CT (Current transformer)

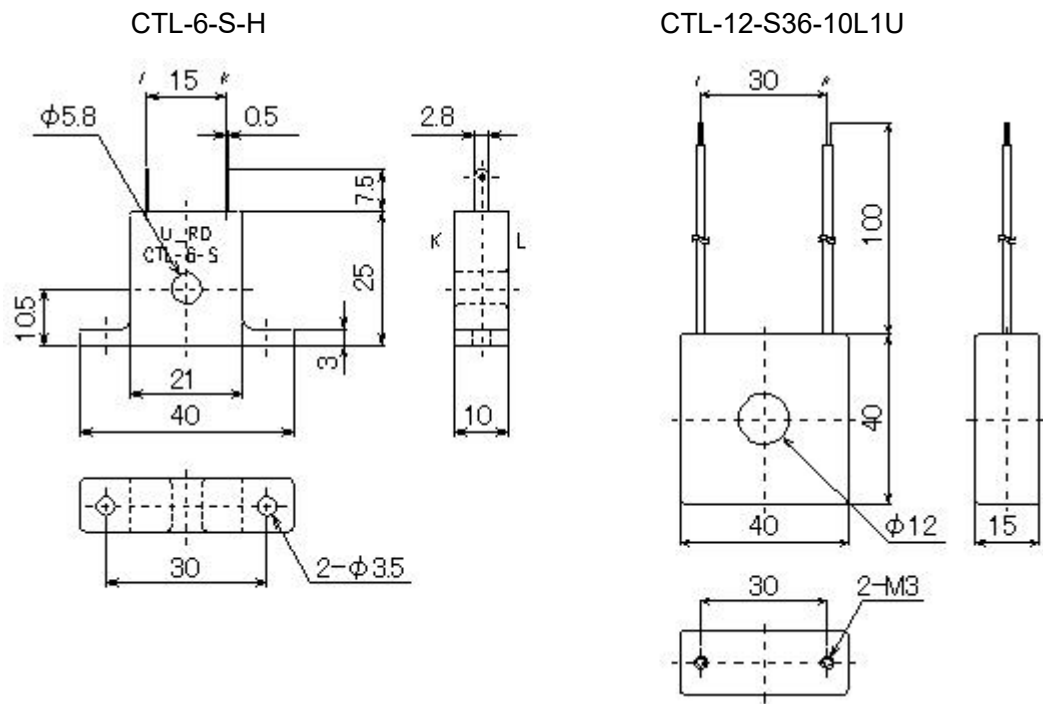

(Fig. 6.2.2-1)

6.3 Mounting

Mounting to the DIN rail

- ① Lower the lock lever of this instrument. (The lock lever of this instrument has a spring structure, but if lower it in the direction of the arrow until it stops, it will be locked in that position.)
- ② Hook the part ② of this instrument onto the top of the DIN rail.
- ③ Insert the lower part of this instrument with the part ② as a fulcrum.
- ④ Raise the lock lever of this instrument.
Make sure it is fixed to the DIN rail.

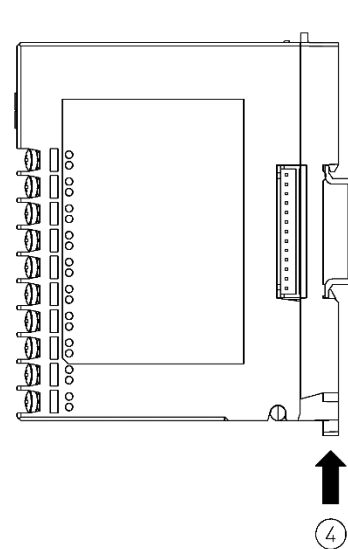
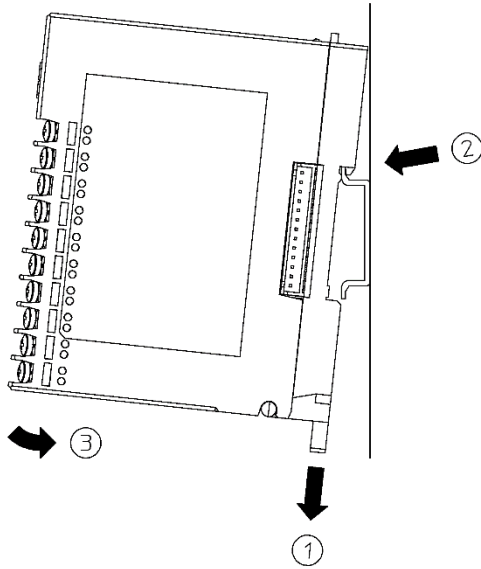

Removal from the DIN rail

- ① Insert a flat blade screwdriver into the lock lever of this instrument and lower the lock lever until it stops.
- ② Remove this instrument from the DIN rail by lifting it from below.

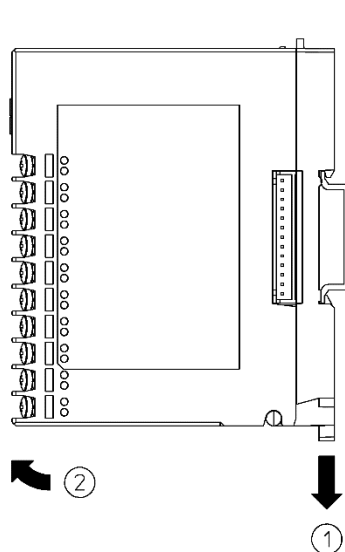

Mounting multiple modules to the DIN rail

This section describes an example of mounting multiple control modules QTC-4 on the DIN rail.

- ① Remove the line cap on the right side of the QTC1-4P.
- ② Lower the lock lever of the QTC1-40, and mounting the QTC1-40 to the DIN rail.
- ③ Slide the QTC1-40 to the left and connect the connectors to each other.
- ④ Raise the lock lever of this instrument.
Make sure it is fixed to the DIN rail.

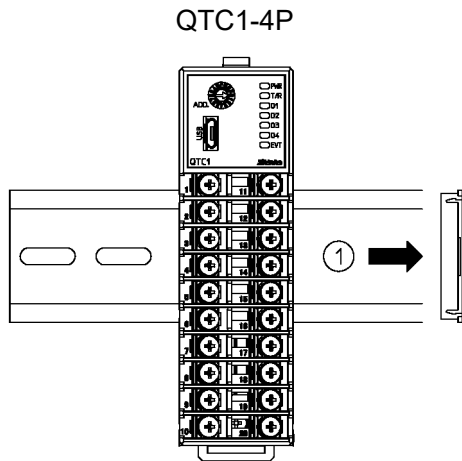

(Fig. 6.3-4)

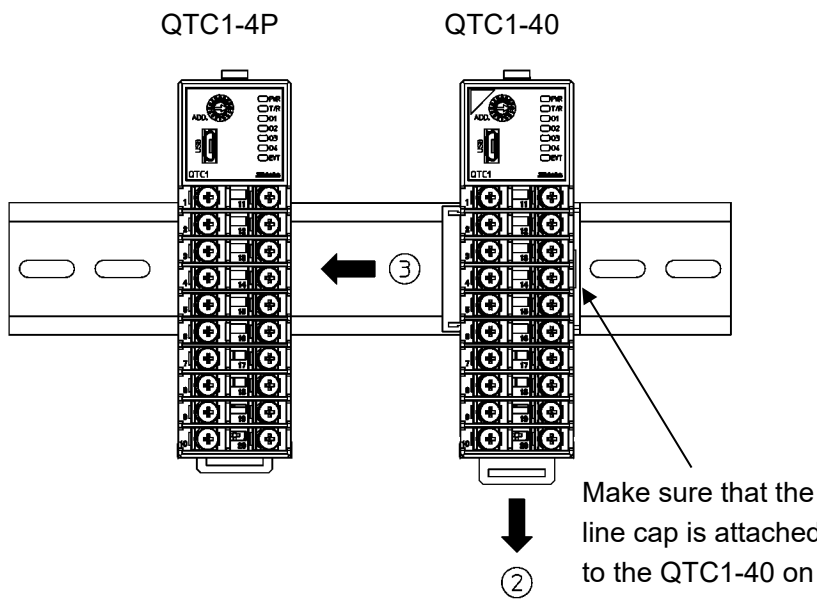

(Fig. 6.3-5)

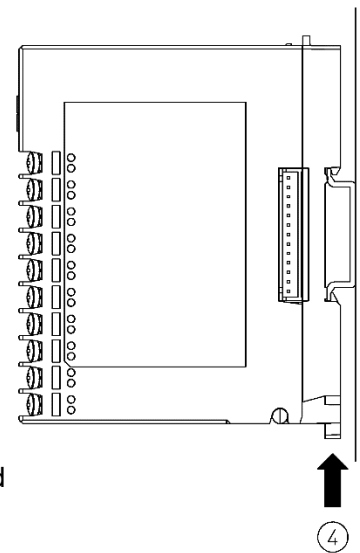

(Fig. 6.3-6)

This section describes an example of mounting communication expansion module QMC1-C□ and control module QTC1-40 on the DIN rail.

- ① Remove the line cap on the right side of the QMC1-C□.
- ② Lower the lock lever of the QTC1-40, and mounting the QTC1-40 to the DIN rail.
- ③ Slide the QTC1-40 to the left and connect the connectors to each other.
- ④ Raise the lock lever of the QTC1-40.
Make sure it is fixed to the DIN rail.

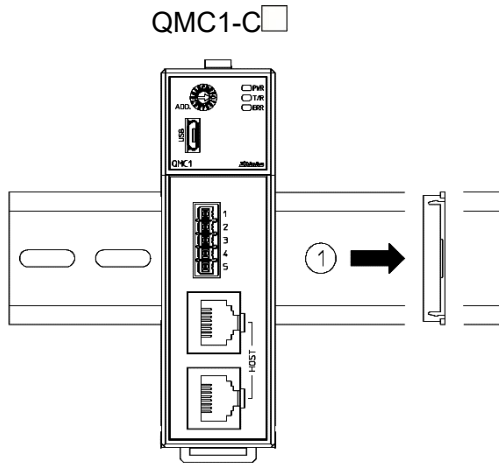

(Fig. 6.3-7)

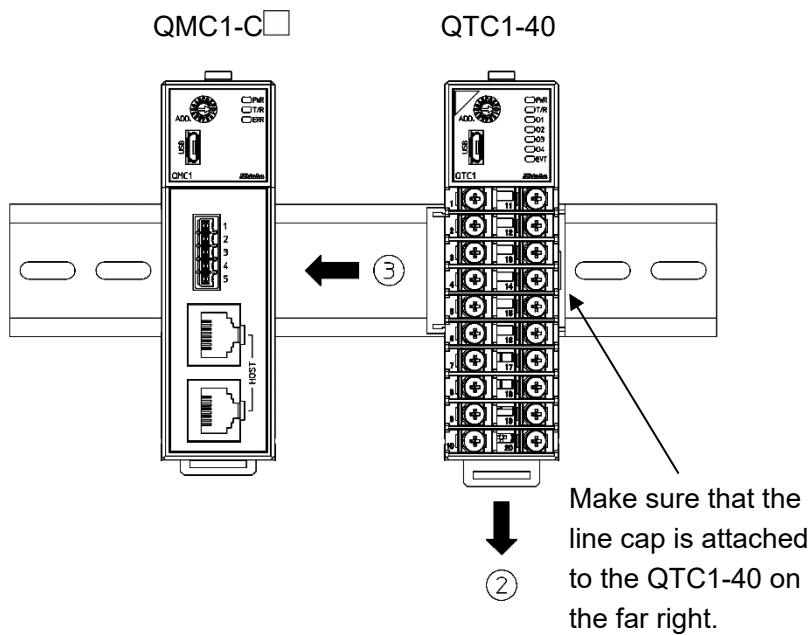

(Fig. 6.3-8)

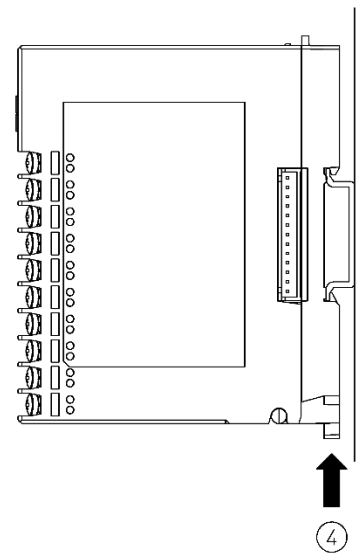

(Fig. 6.3-9)

Removal multiple modules from the DIN rail

This section describes an example of removing multiple control modules QTC-4 on the DIN rail.

- ① Insert a flat blade screwdriver into the lock lever of the QTC1-40 and lower the lock lever until it stops.
- ② Slide QTC1-40 to the right side and disconnect it from the connector, then remove it from the DIN rail.

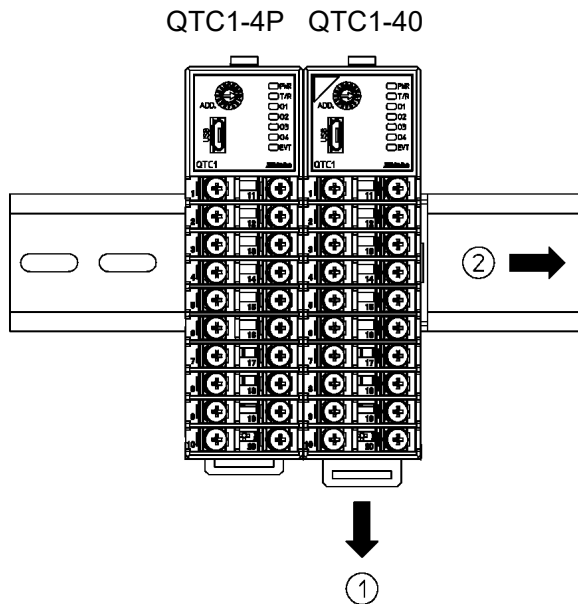

(Fig. 6.3-10)

7 Wiring



Warning

Turn off the power supply to this instrument before wiring.

If you work while the power is supplied, you may get an electric shock, which could result in an accident resulting in death or serious injury.

7.1 Recommended Terminal and Recommended Rod Terminal

Recommended terminal

Use a solderless terminal with an insulation sleeve in which an M3 screw fits as shown below.

Use ring-type solderless terminals for the power supply section, serial communication section and CUnet communication section.

Solderless Terminal	Manufacturer	Model	Compatible wire size	Tightening torque
Y-type	NICHIFU TERMINAL INDUSTRIES CO., LTD.	TMEX1.25Y-3	AWG22 to 16	Input/output section: 0.63 N•m Power supply section: 0.5 N•m Serial communication section: 0.3 N•m CUnet communication section: 0.3 N•m
	J.S.TMFG.CO.,LTD.	VD1.25-B3A	AWG22 to 16	
Ring-type	NICHIFU TERMINAL INDUSTRIES CO., LTD.	TMEX1.25-3	AWG22 to 16	
		TMEX2-3S	AWG16 to 14	
	J.S.TMFG.CO.,LTD.	V1.25-3	AWG22 to 16	
		V1.25-3	AWG16 to 14	

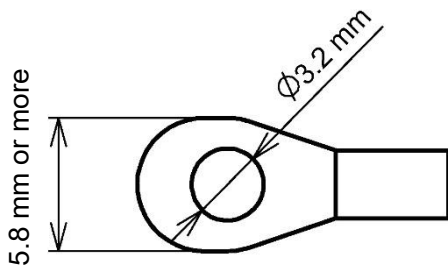

(Fig. 7.1-1)

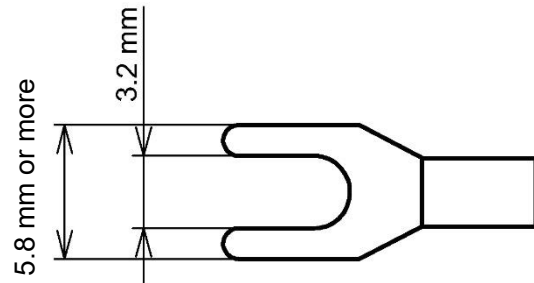

(Fig. 7.1-2)

Recommended rod terminal (connector specifications)

For connector specifications, use PHOENIX CONTACT brand rod terminals with insulating sleeves and crimping tools for the input/output sections.

Model	AWG	Crimping tool
AI 0,25-10 YE	AWG24	ZA3 CRIMPFOX UD 6
AI 0,34-10 TQ	AWG22	
AI 0.5-10 WH	AWG20	
AI 0,75-10 GY or AI 1-10 RD	AWG18	
AI 1,5-10 BK	AWG16	
AI 2,5-10 BU	AWG14	
AI 4-10 GY	AWG12	

7.2 Using Terminal Cover Precaution

Attach the terminal cover TC-QTC (sold separately) so that the shorter one is on the right side of the case.

For the wiring of terminal numbers 11 to 20, pass through the left side of the terminal cover.

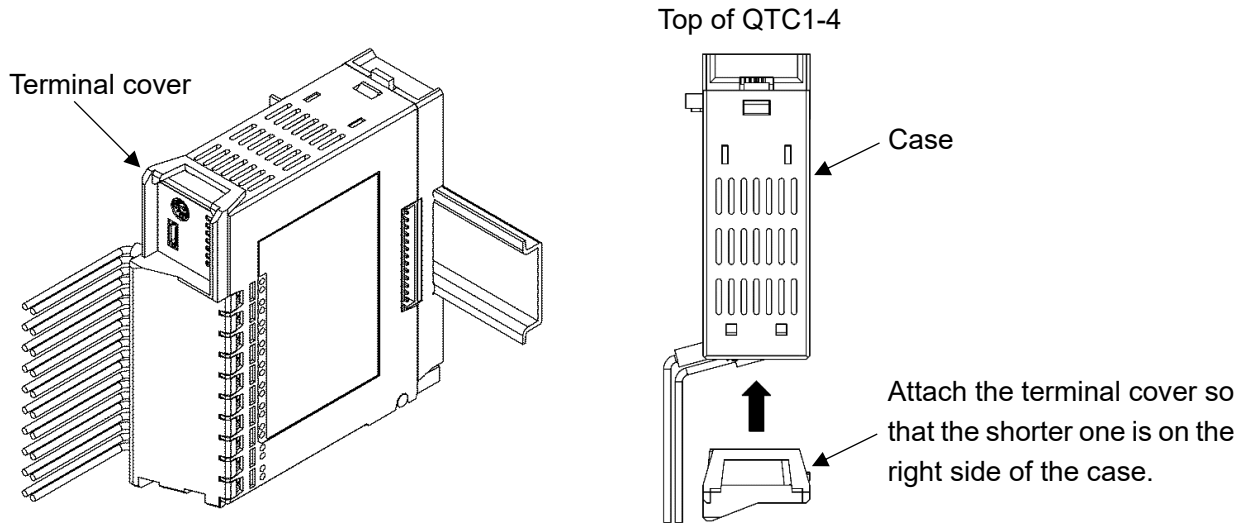

(Fig. 7.2-1)

(Fig. 7.2-2)

7.3 Terminal Arrangement

7.3.1 Input and Output Terminal Arrangement

Terminal block type

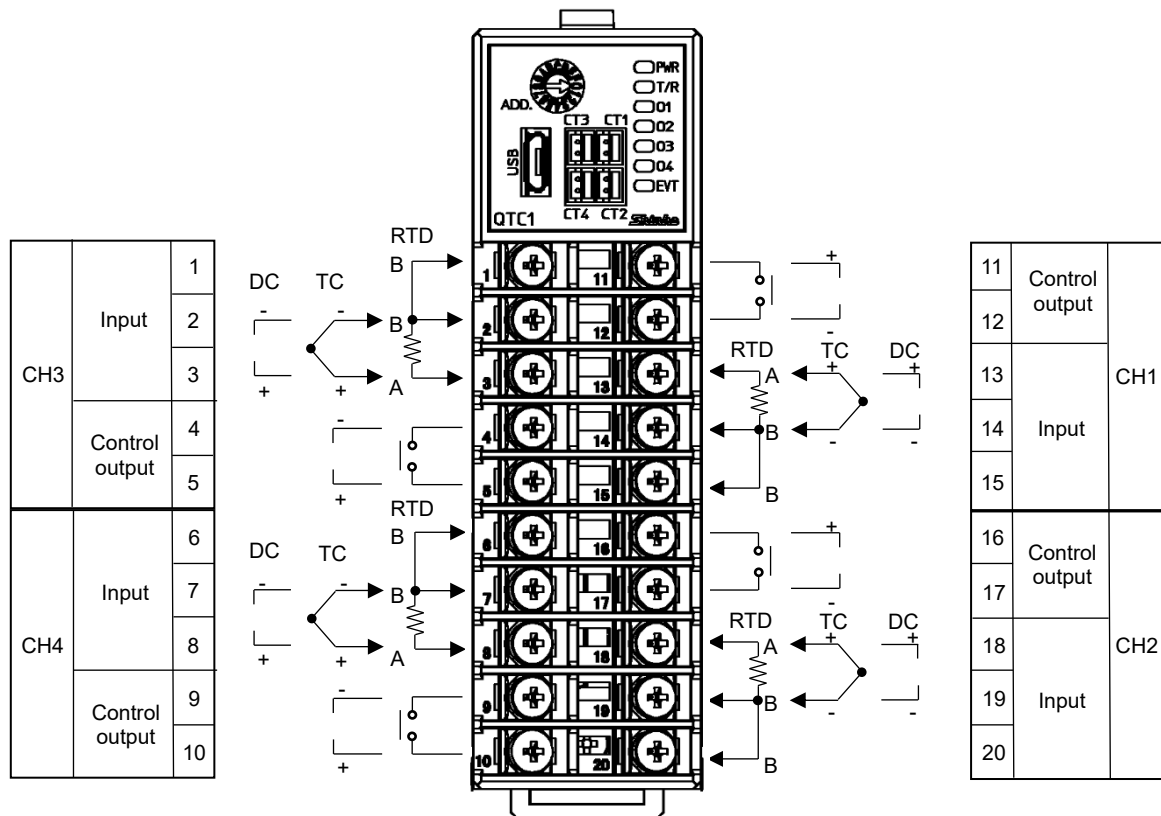

(Fig. 7.3.1-1)

Connector type

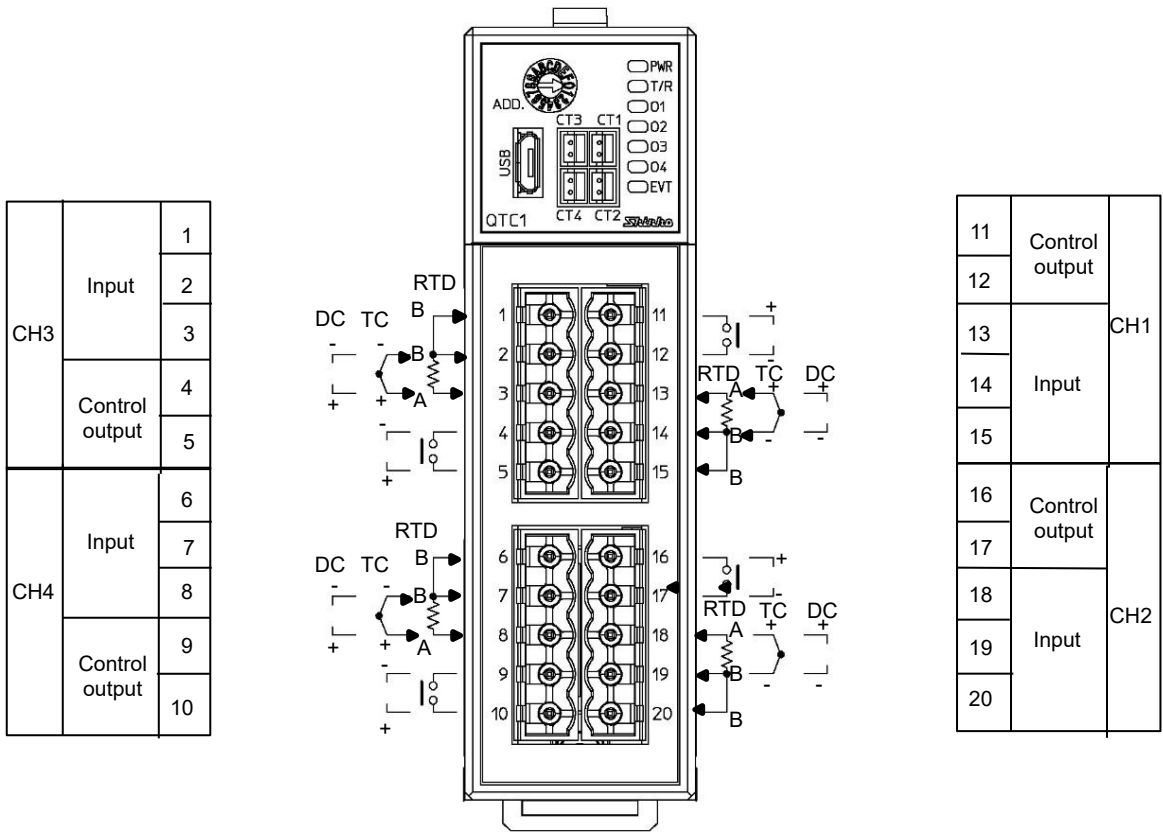

(Fig. 7.3.1-2)

7.3.2 Power Supply and Serial Communication Terminal Arrangement

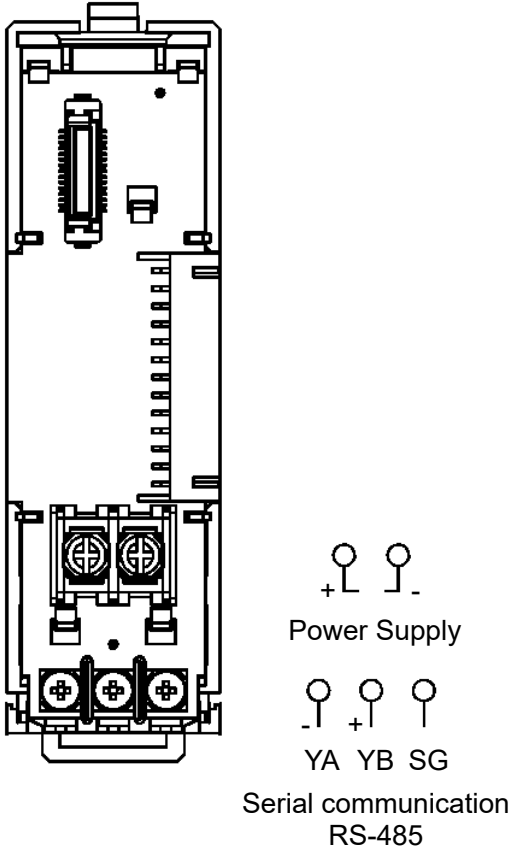

(Fig. 7.3.2-1)

7.3.3 Power Supply and CUNet Communication Terminal Arrangement

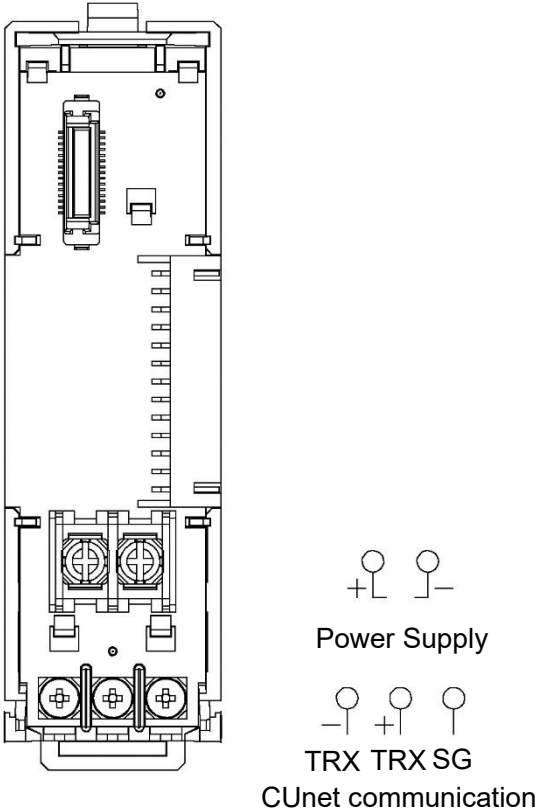

(Fig. 7.3.3-1)

7.3.4 Event Input and Output Terminal Arrangement

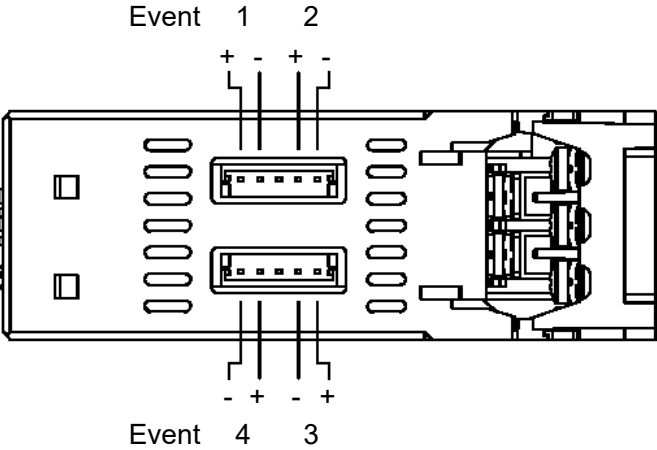

(Fig. 7.3.4-1)

7.4 Wiring

7.4.1 Wiring for Power Supply and Serial Communication / CUNet Communication

The terminal block for power supply and serial communication / CUNet communication is located on the base of this instrument.

Wiring by the following procedure.

(1) Case removal

- ① Push the release lever on the top of this instrument to unlock it.
- ② Remove the case.

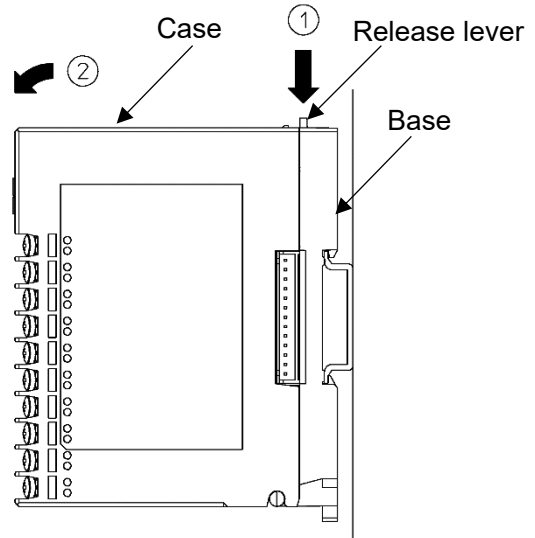

(Fig. 7.4.1-1)

(2) Wiring

Serial communication

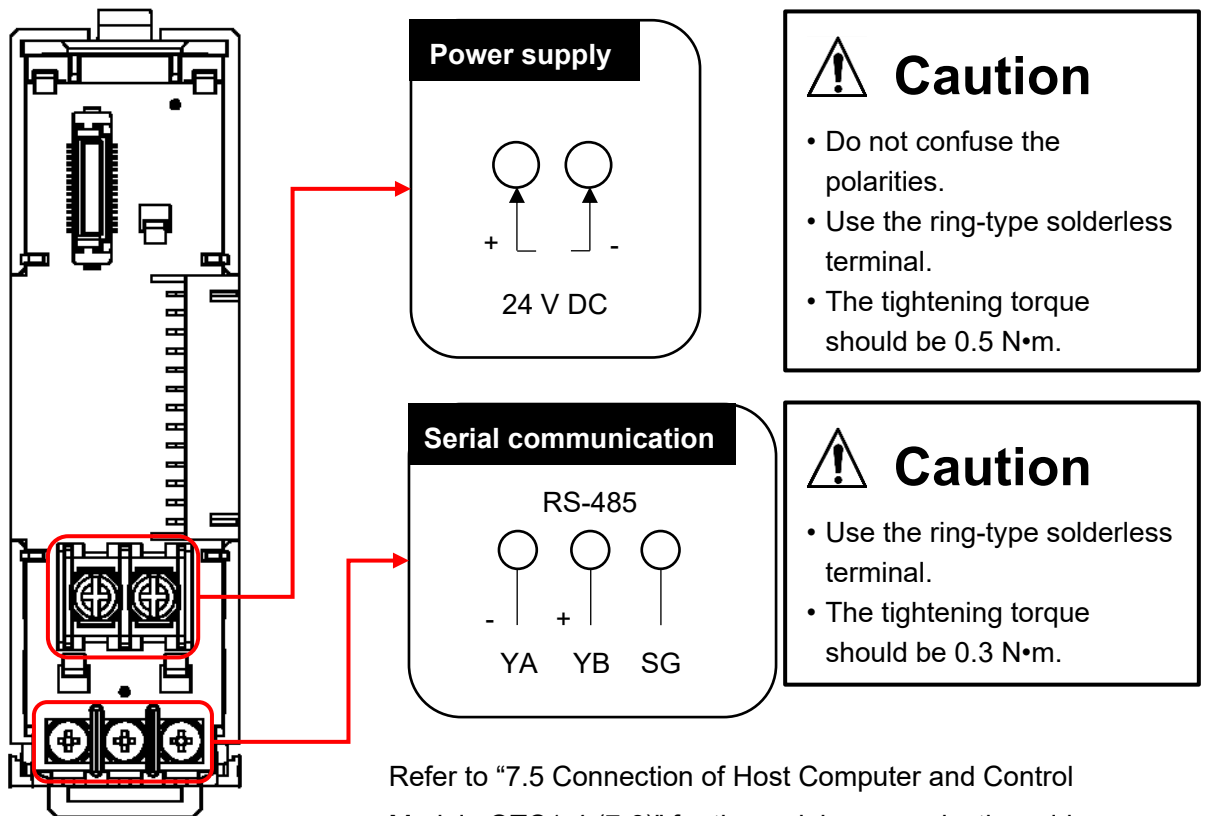

Refer to “7.5 Connection of Host Computer and Control Module QTC1-4 (7-8)” for the serial communication wiring.

(Fig. 7.4.1-2)

About termination resistance

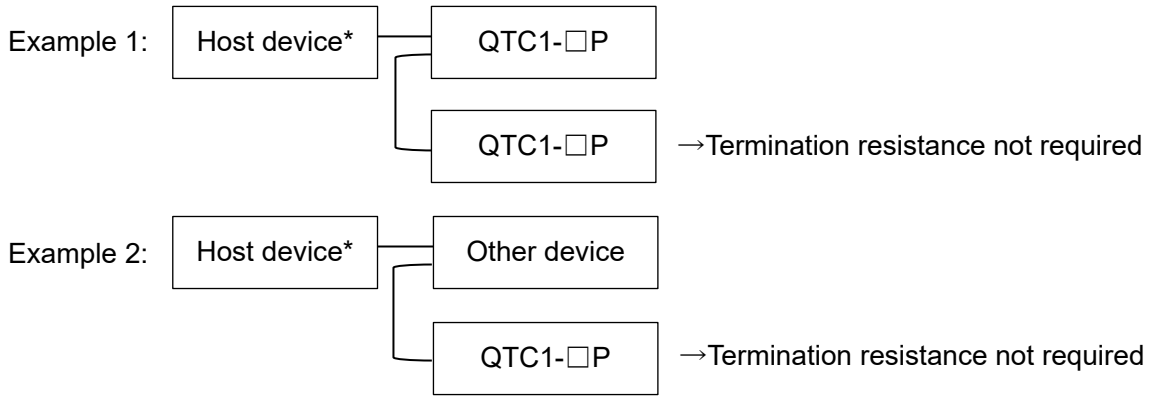

*Install the termination resistance of the host device in accordance with the instruction manual of the host device.

(Fig. 7.4.1-3)

CUnet communication

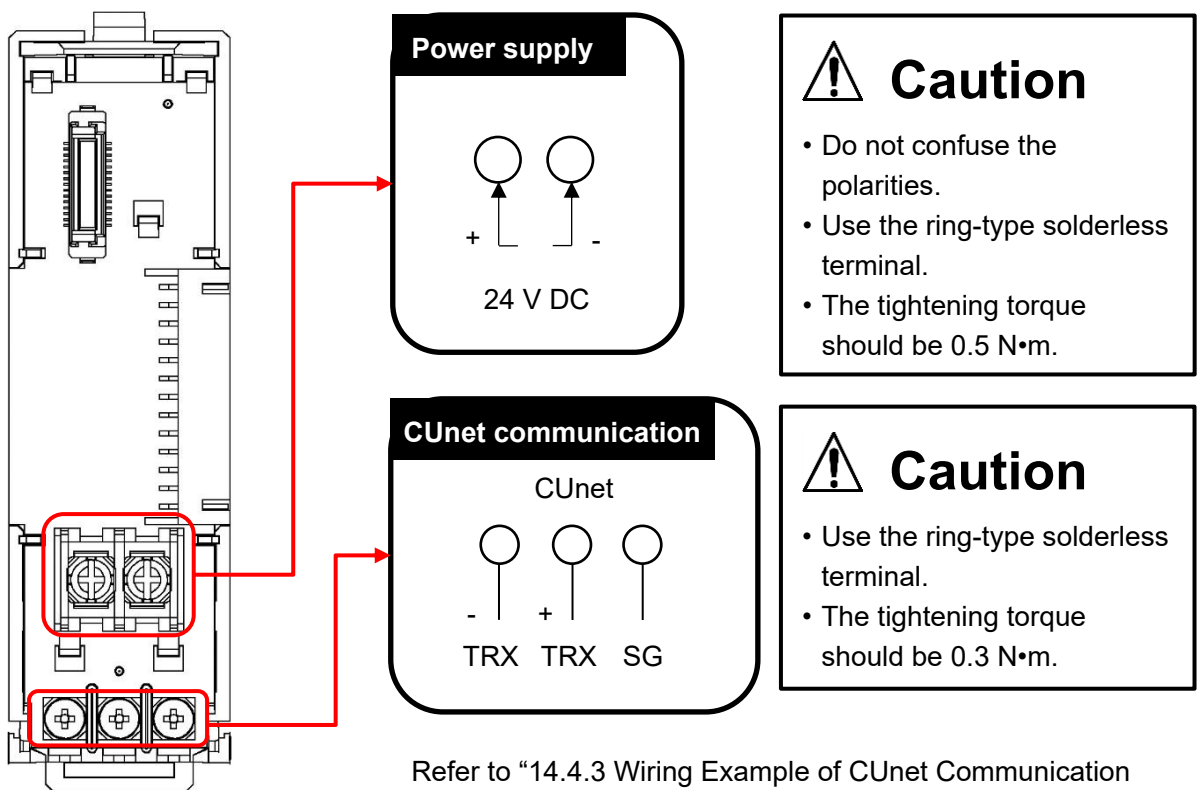

Refer to “14.4.3 Wiring Example of CUnet Communication Line” (P.14-10) for the wiring of CUnet communication.

(Fig. 7.4.1-4)

(3) Case mounting

- ① Hook the case on the lower part ① of this instrument.
- ② Mount the case so that the lower part ① of this instrument is the fulcrum and covers the release lever. There is a clicking sound.

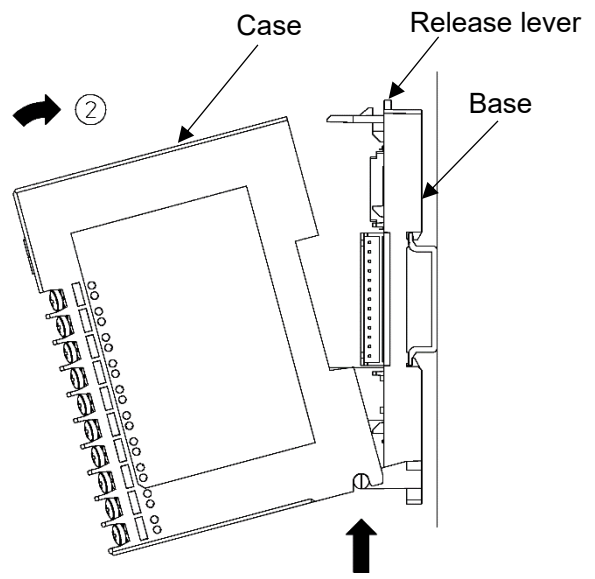

①
(Fig. 7.4.1-5)

7.4.2 Wiring for Input, Output and CT
Terminal block type

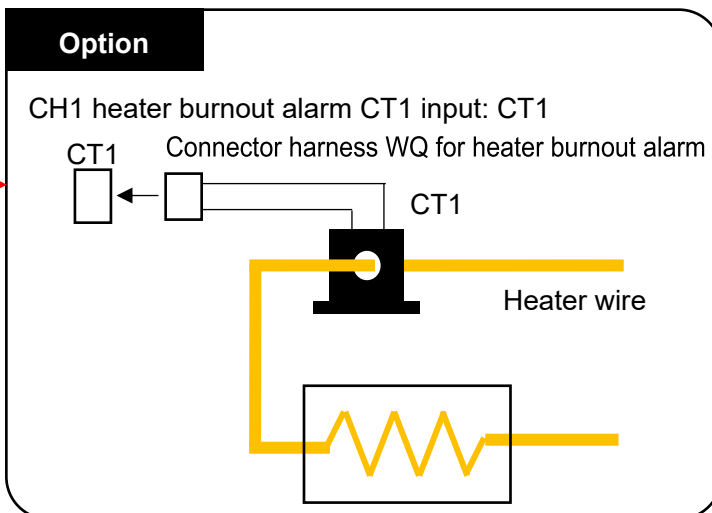
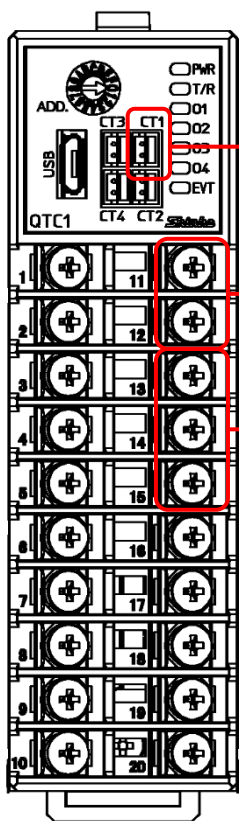

CH2 heater burnout alarm CT1 input: CT2
 CH3 heater burnout alarm CT1 input: CT3
 CH4 heater burnout alarm CT1 input: CT4

Caution

- Please note that CH1, CH2 and CH3, CH4 have different terminal arrangements.
- The tightening torque should be 0.63 N•m.

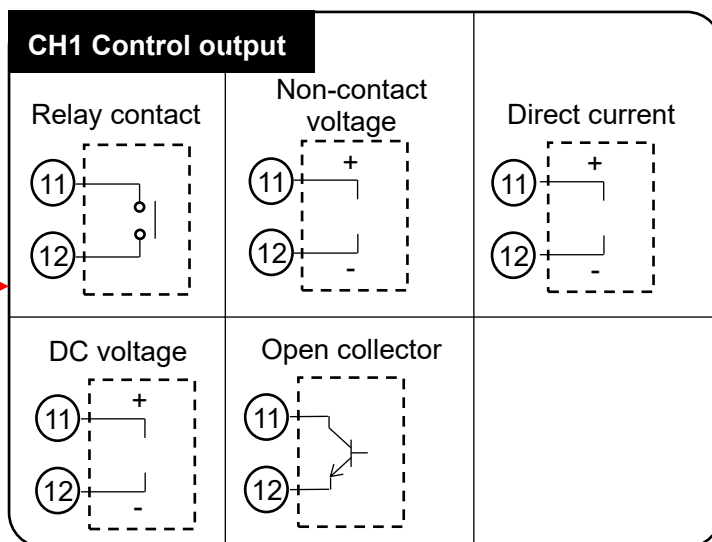

CH2 Control output: ⑩ ⑨
 CH3 Control output: ⑤ ④
 CH4 Control output: ⑩ ⑨

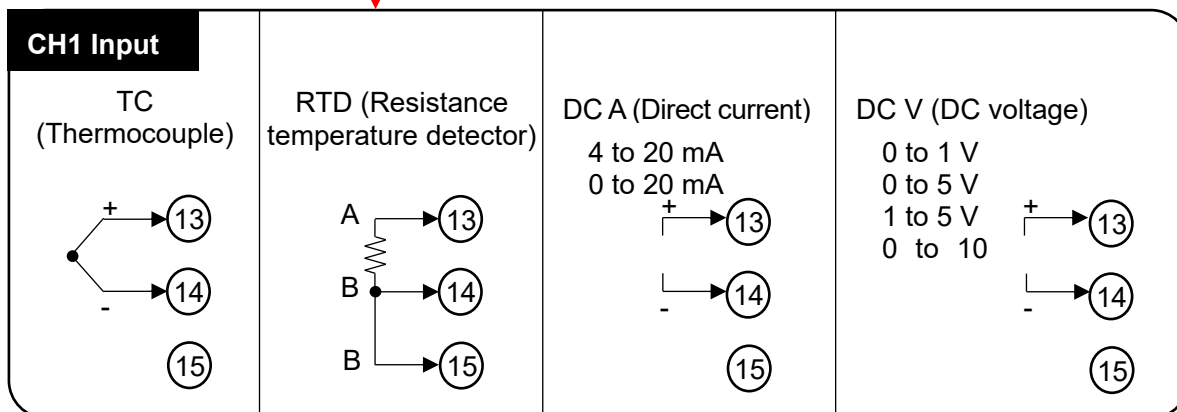

CH2 Input: ⑱ ⑲ ⑳
 CH3 Input: ③ ② ①
 CH4 Input: ⑧ ⑦ ⑥

(Fig. 7.4.2-1)

Connector type

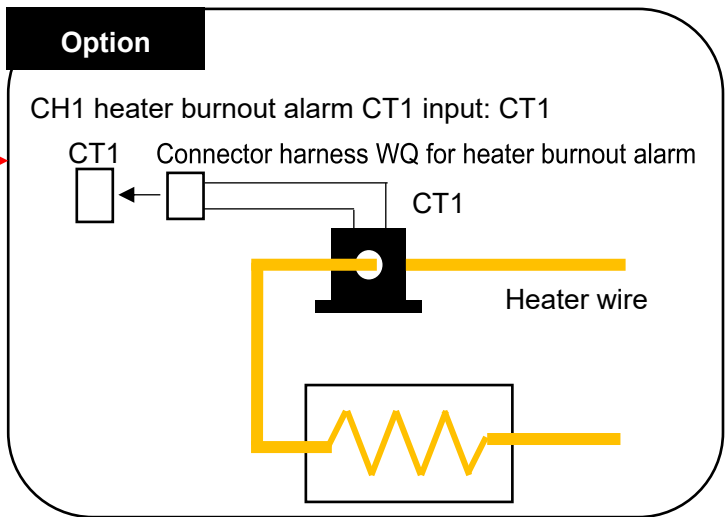
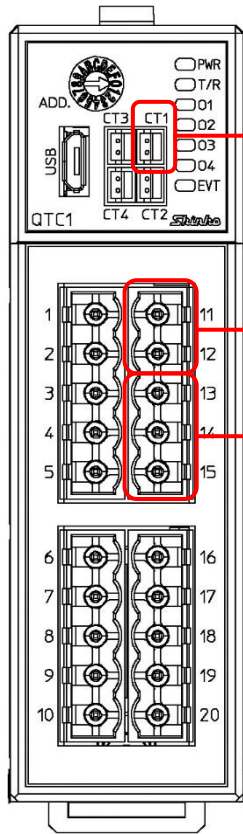

CH2 heater burnout alarm CT1 input: CT2
 CH3 heater burnout alarm CT1 input: CT3
 CH4 heater burnout alarm CT1 input: CT4

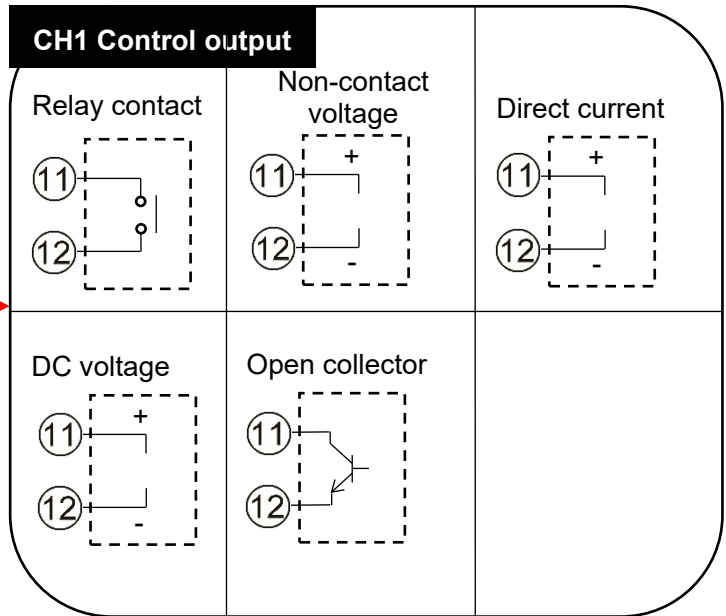

CH2 Control output: ①⑥ ①⑦
 CH3 Control output: ⑤ ④
 CH4 Control output: ⑩ ⑨

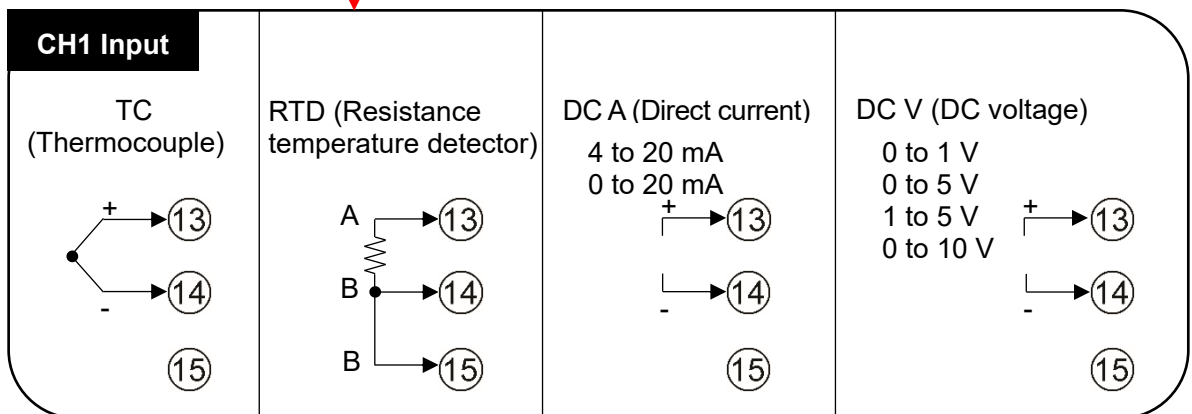

CH2 Input: ①⑧ ①⑨ ②⑩
 CH3 Input: ③ ② ①
 CH4 Input: ⑧ ⑦ ⑥

(Fig. 7.4.2-2)

7.4.3 Wiring for Event Input and Event Output

Using the connector harness EVQ for event input/output.

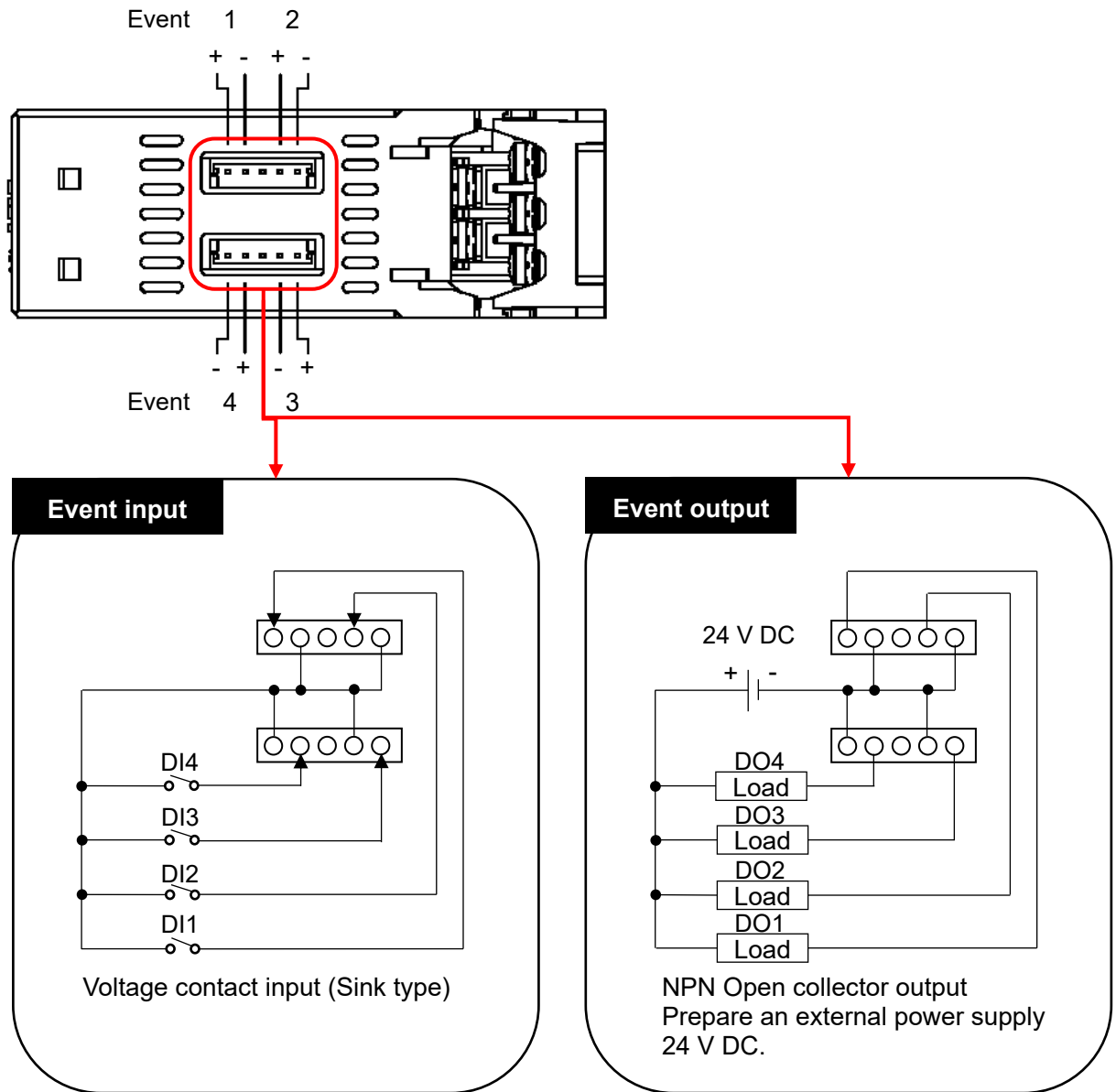

(Fig. 7.4.3-1)

7.5 Connection of Host Computer and Control Module QTC1-4

7.5.1 Wiring Example for Using USB Communication Cable CMC-001-1 (Sold separately)

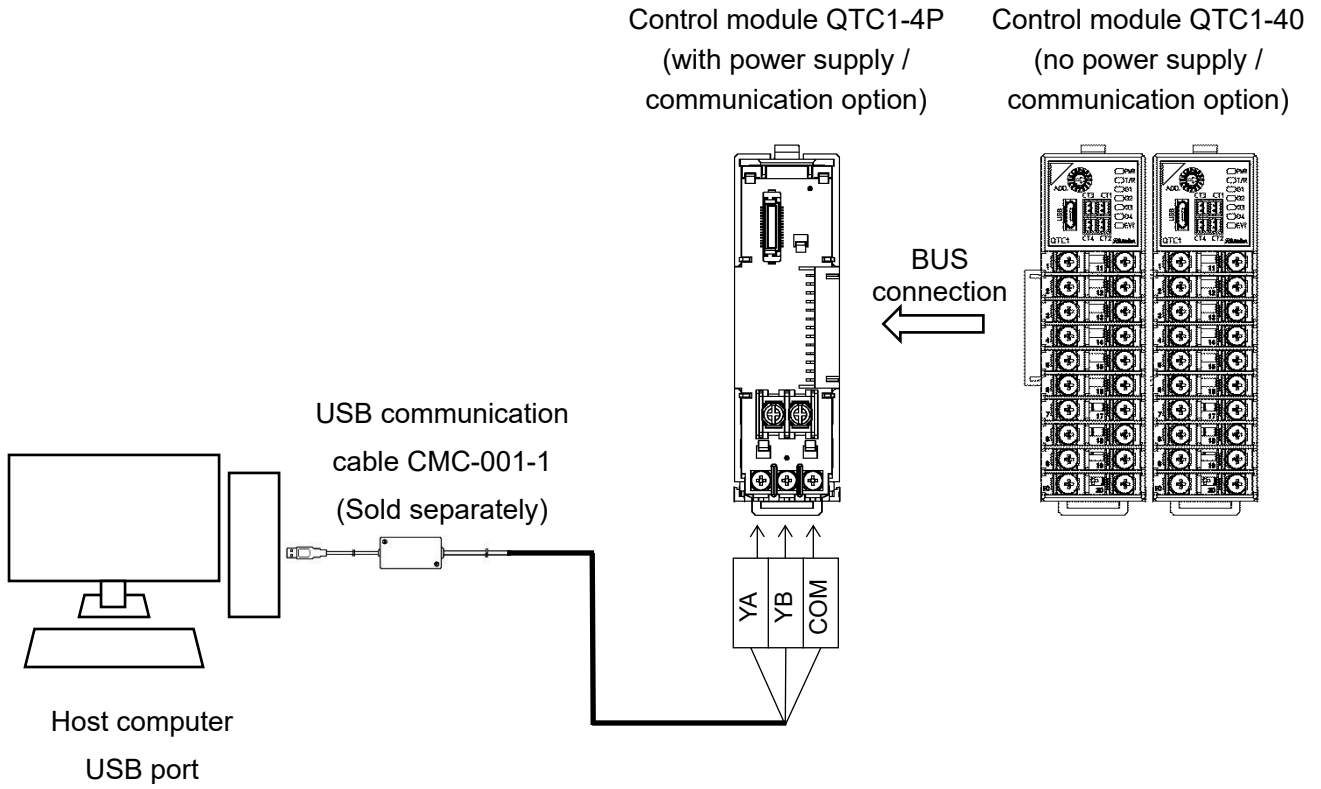

(Fig. 7.5.1-1)

7.5.2 Wiring Example for Using Communication Converter IF-400 (Sold separately)

The communication converter IF-400 (sold separately) does not support communication speeds of 38400 bps and 57600 bps.

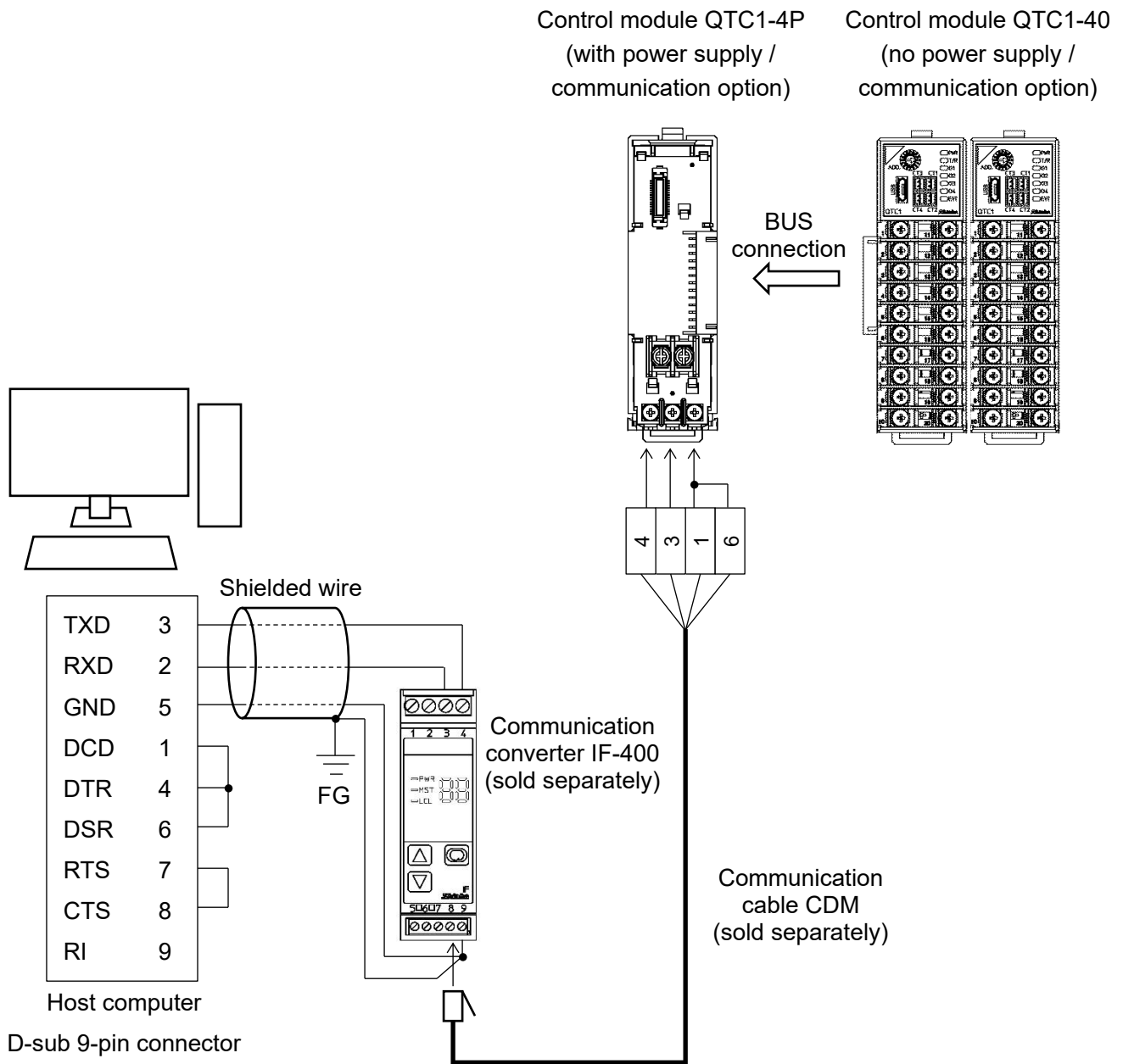

(Fig. 7.5.2-1)

Shielded wire

Connect only one side of the shielded wire to FG so that no current flows in the shield part. If both sides of the shield are connected to FG, a closed circuit will be created between the shielded wire and the ground, and a current will flow through the shielded wire, making it more susceptible to noise. Be sure to ground FG.

Recommended cable: OTSC-VB 2PX0.5SQ by Onamba Co., Ltd. or equivalent (use twisted pair shielded wire).

Termination resistor (terminator)

The communication converter IF-400 (sold separately) has a built-in termination resistor.

The termination resistor is also called a terminator. It is a resistor attached to the end of wiring when peripheral devices are connected to the host computer in a chain, and prevents signal reflection and signal disturbance at the end.

Since this instrument has a built-in pull-up resistor and pull-down resistor, no termination resistor is required on the communication line.

8 Setting of Specification



Caution

The console software (SWC-QTC101M) is common to QTC1-2.

Set the specifications.

This section describes how to set specifications using console software (SWC-QTC101M).

8.1 Preparation

8.1.1 Preparation of USB Communication Cable and Console Software

Please prepare the USB communication cable and the console software.

- USB communication cable
USB-micro USB Type-B (commercial item)
- Console software (SWC-QTC101M)
Please download from our website and install.
Click <https://shinko-technos.co.jp/e/> → Support/Download → Software

8.1.2 Connecting to Host Computer



Caution

Do not use the logging function of the console software when communicating by connecting the USB communication cable.

- (1) Connect the micro USB Type-B side of the USB communication cable to the console communication connector of this instrument.
- (2) Connect the USB plug of the USB communication cable to the USB port of the host computer.

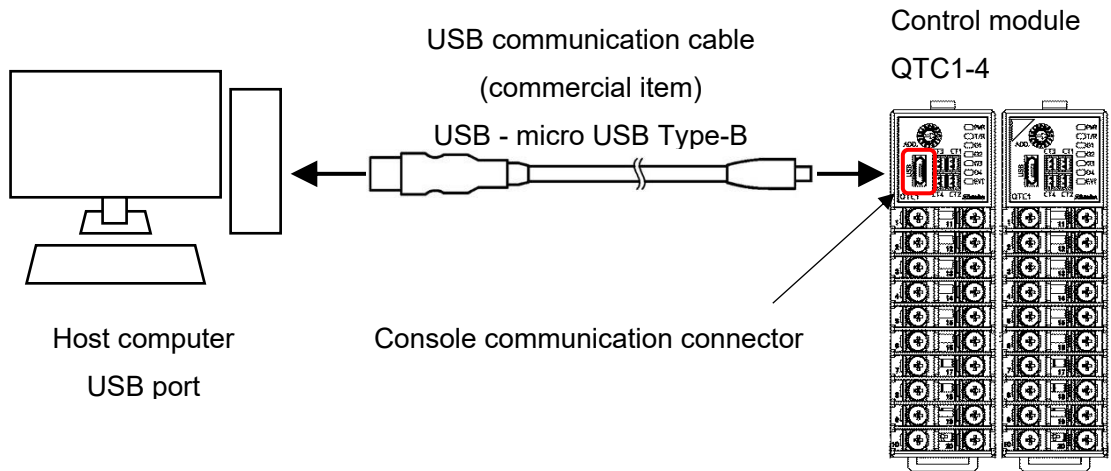

(Fig. 8.1.2-1)

(3) Checking the COM port number

Follow the procedure below to check the COM port number.

- ① Right-click "Start" → Click "Device manager" from menu.
- ② When "USB Serial Port (COM3)" is displayed in "Port (COM and LPT)", the COM port is assigned to No. 3.
Check the COM port number, and then close "Device Manager".

(4) Starting the console software (SWC-QTC101M)

- ① Start the console software (SWC-QTC101M).
Select "QTC1-4" in the Device selection.

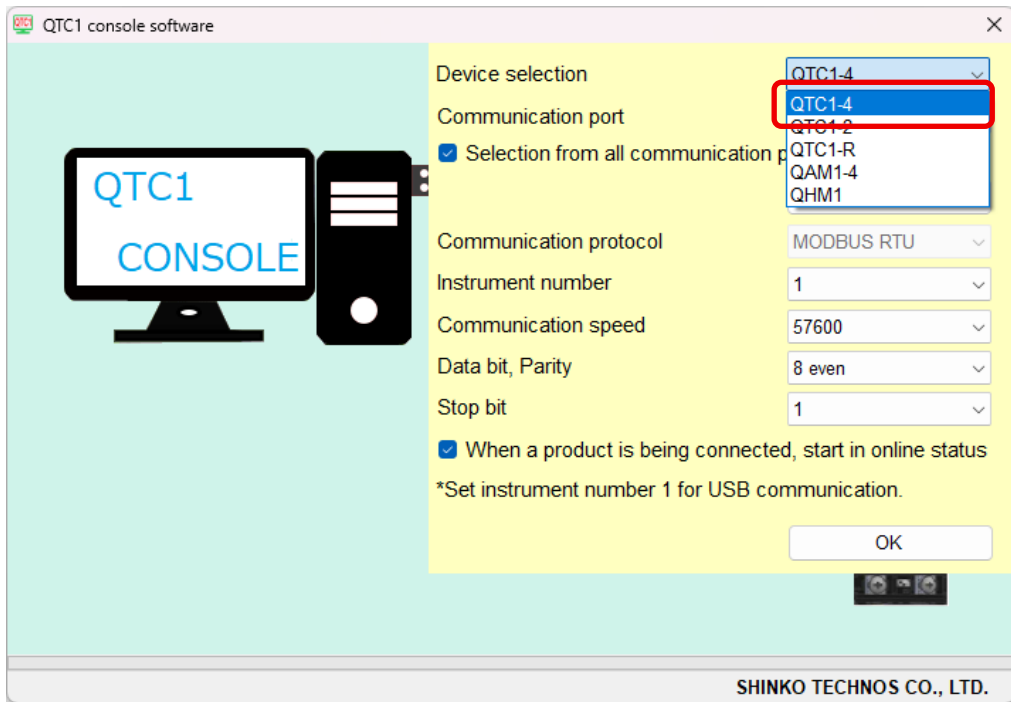

(Fig. 8.1.2-2)

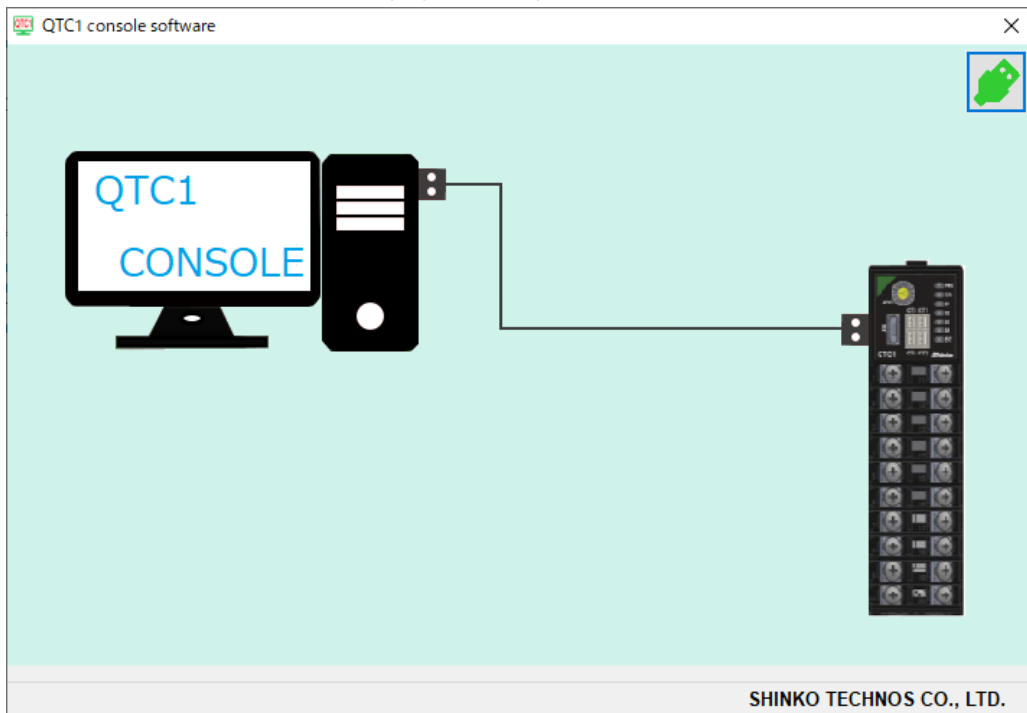

(Fig. 8.1.2-3)

- ② Click [User (U)] on the menu bar → [Communication condition (C)].
 Display the communication condition setting screen.

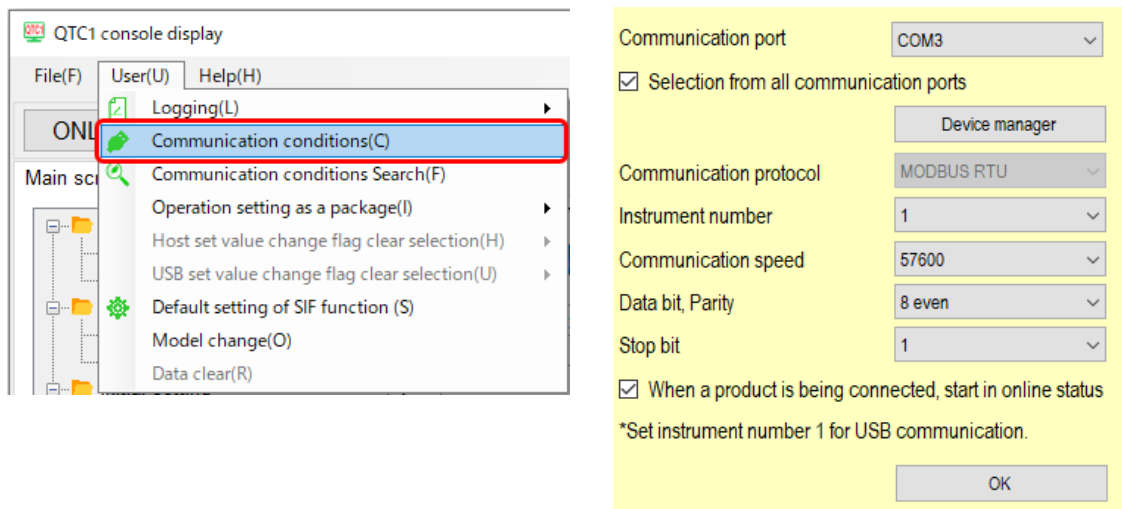

(Fig. 8.1.2-4)

※*The model "QTC1-4" can also be selected from User (U) - Model change (o) in the menu bar.

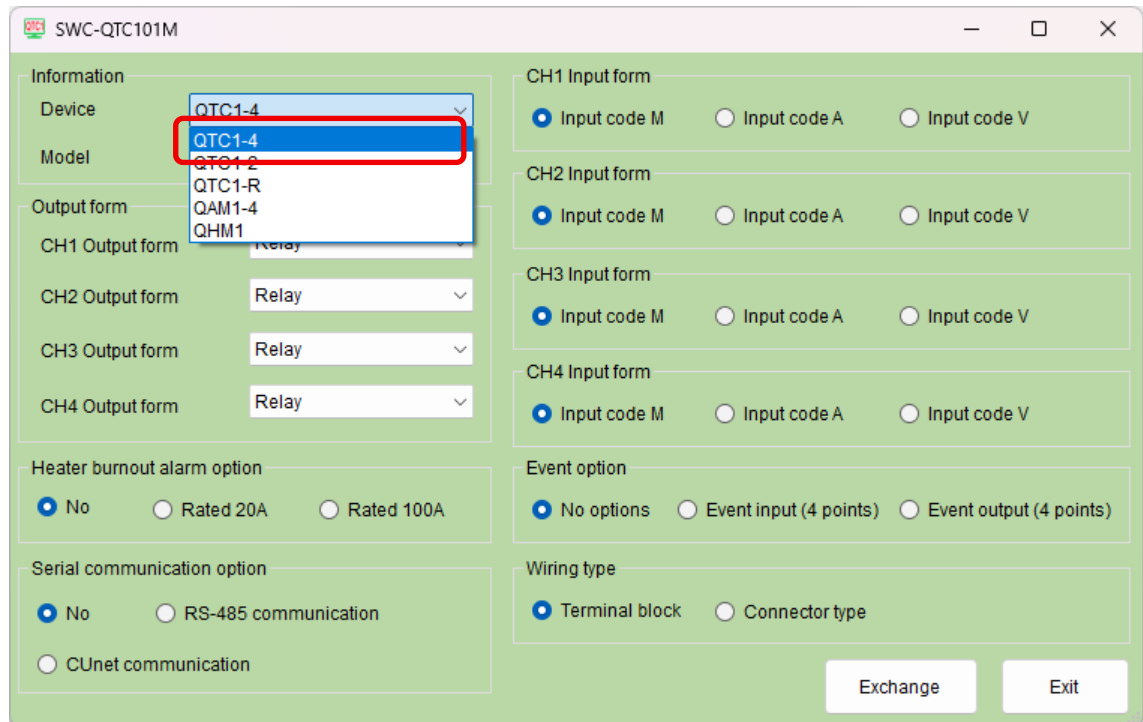

(Fig. 8.1.2-5)

- ③ Set the communication condition as shown below.

Setup Items	Setting Value
Communication port	Select the COM port number confirmed in ② of (3).
Communication protocol	MODBUS RTU

- ④ Click [OK]

- ⑤ Click [File (F)] on the menu bar → [Instrument to PC (U)].

Read all the setting values of the connected control module QTC1-4.

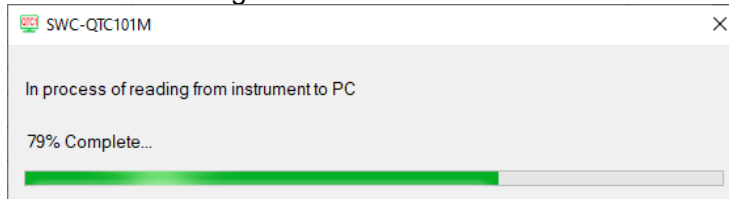

(Fig. 8.1.2-6)

- ⑥ Display the monitor value screen.

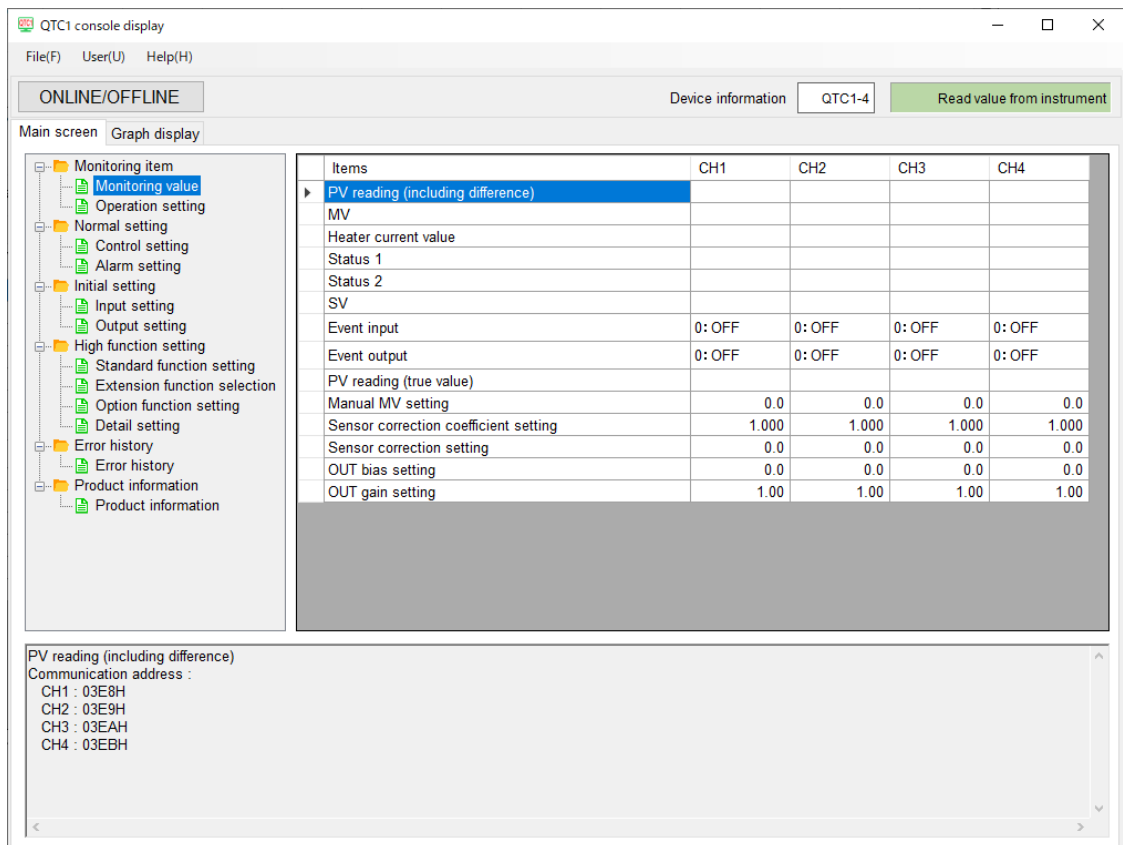

(Fig. 8.1.2-7)

The specifications are ready.

Please refer to "8.2 Specification Setting (P.8-5 to 8-41)" to set the specifications.

Setting the specifications for the second and subsequent modules

To set the specifications of the second and subsequent control modules QTC1-4, follow the procedure below.

- ① Connect the USB communication cable to the console communication connector of the second and subsequent control module QTC1-4.
- ② Click [File (F)] on the menu bar → [Instrument to PC (U)].

Read all the setting values of the connected control module QTC1-4.

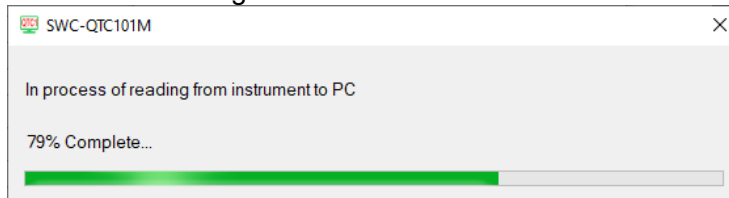

(Fig. 8.1.2-8)

- ③ Display the monitor value screen.

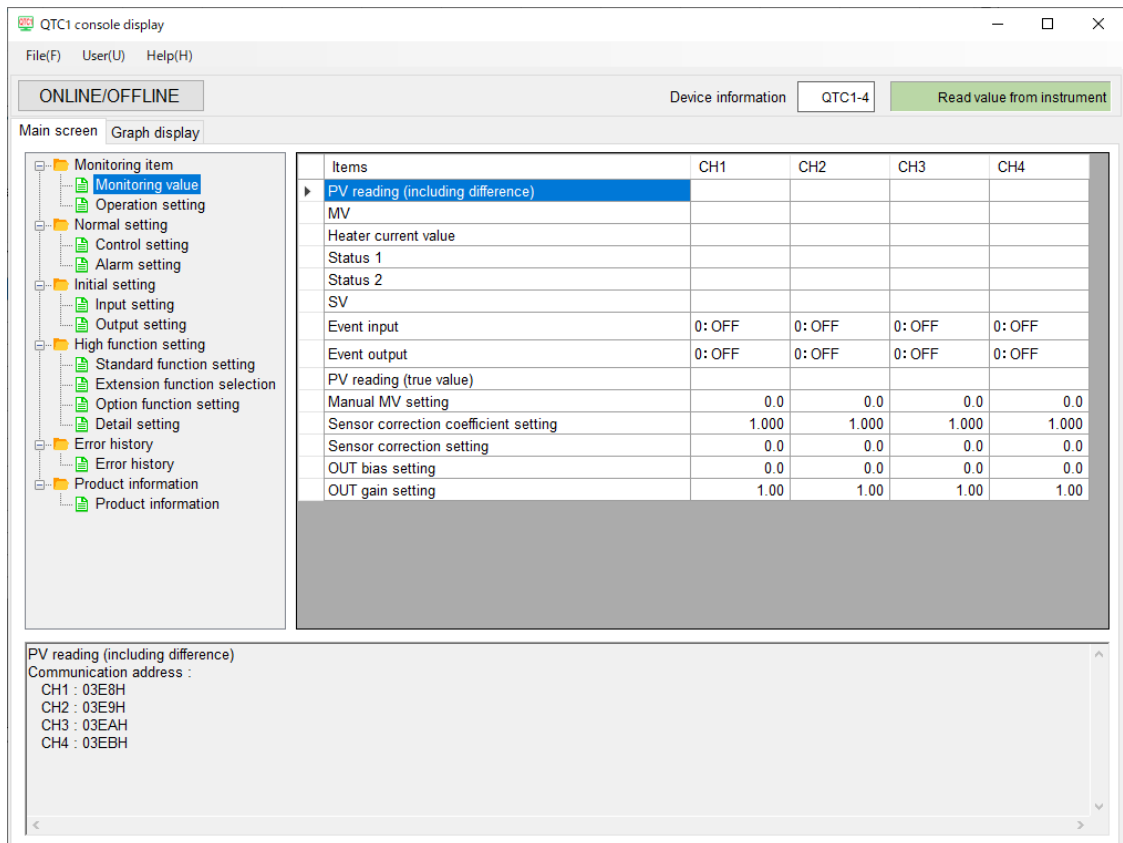

(Fig. 8.1.2-9)

Please refer to "8.2 Specification Setting (P.8-5 to 8-41)" to set the specifications.

8.2 Specification Setting

Basic operation of specification setting

Before setting the specifications, how to select the selection item and how to set the setting item are explained.

Select the selection item

This section explains how to select the selection item by using CH1 control enable/disable selection as an example.

Click on the selection item for the channel.

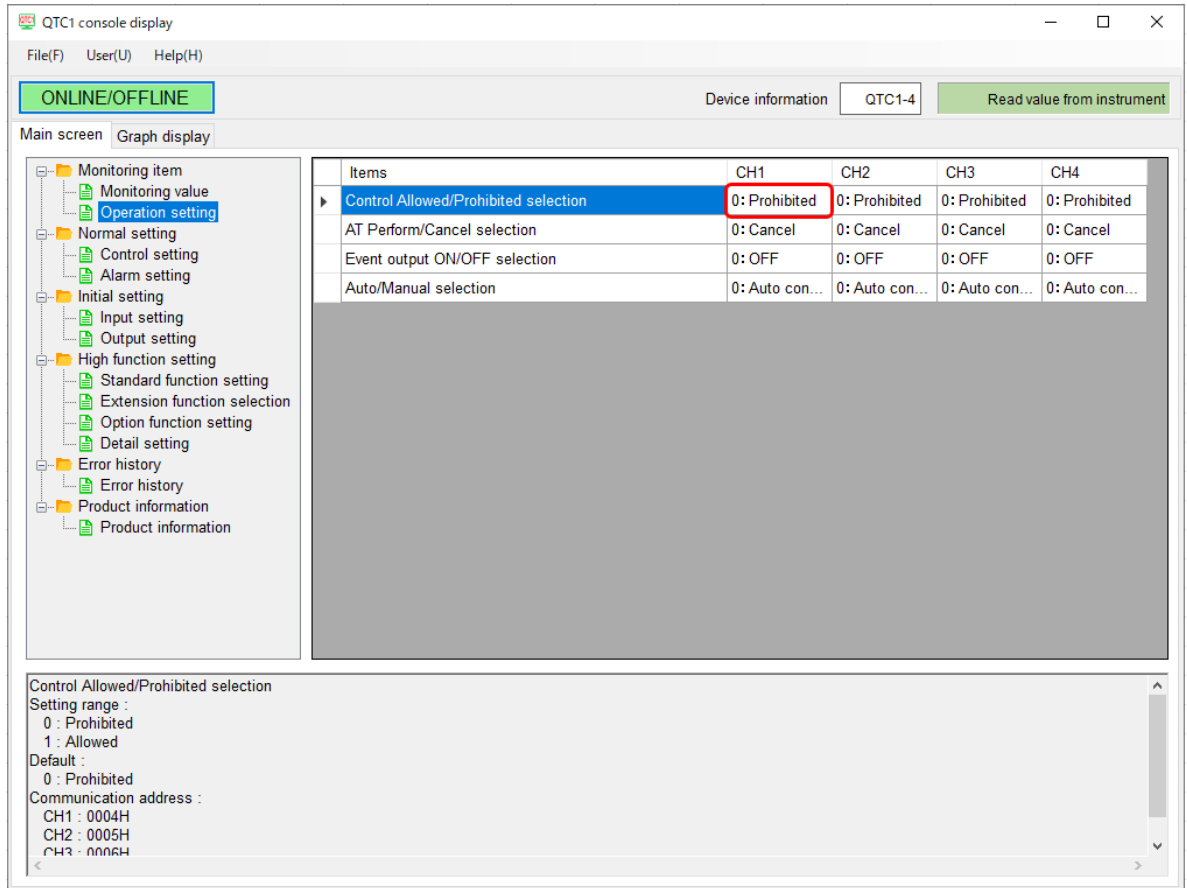

(Fig. 8.2-1)

Display the selection item list.

Click "0: Prohibited" or "1: Allowed".

Transfer the selected contents to the control module QTC1-4.

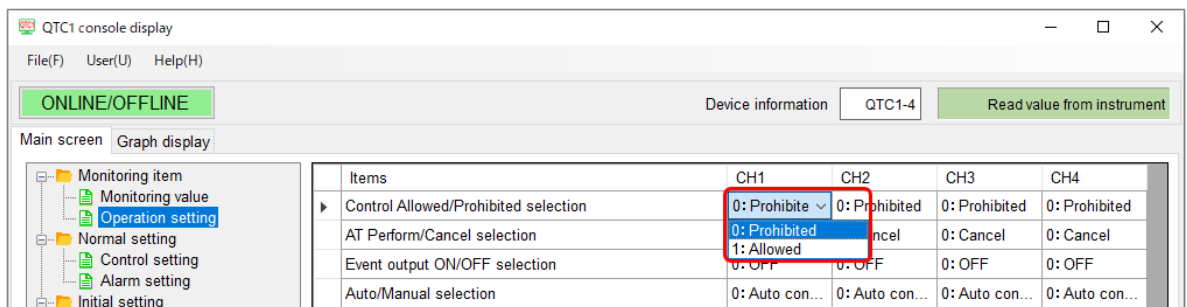

(Fig. 8.2-2)

Set the setting item

This section explains how to set the setting item by using CH1 SV setting as an example.

Click on the setting item for the channel.

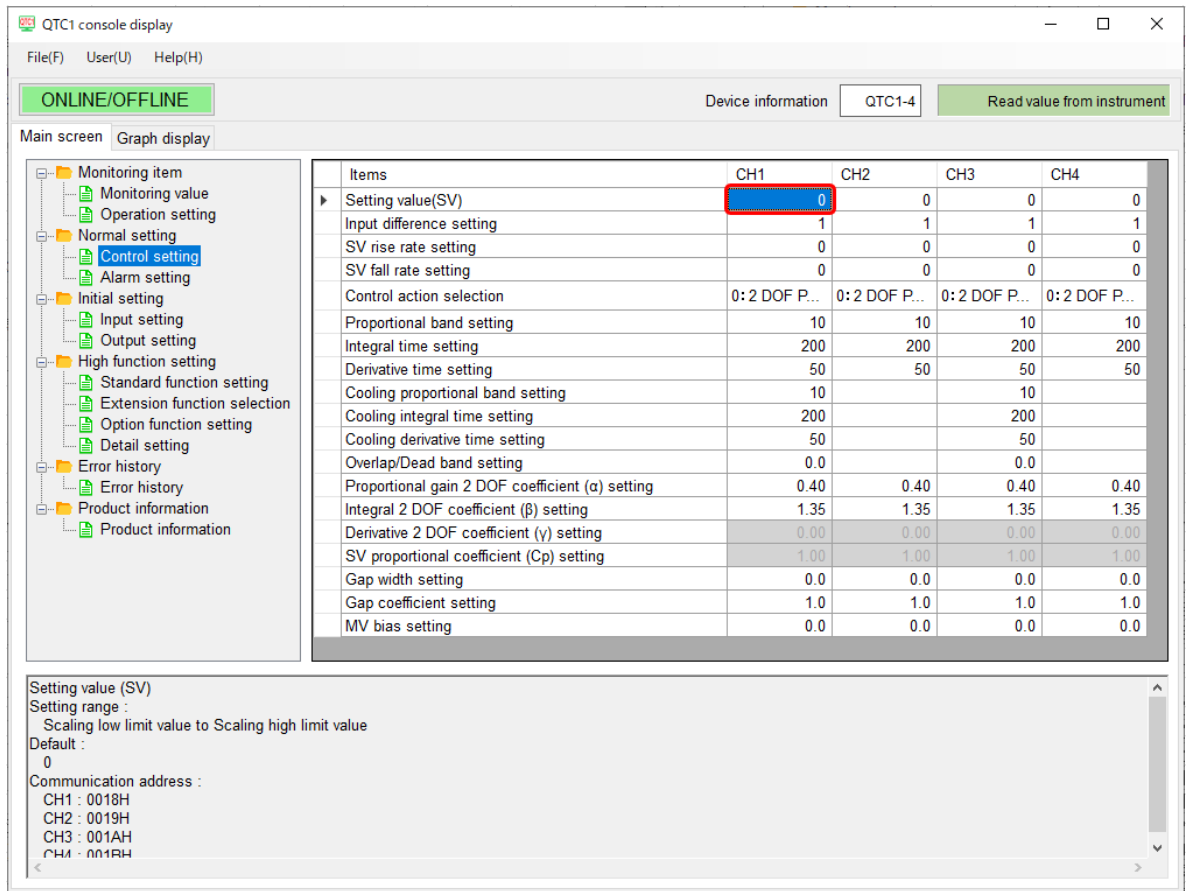

(Fig. 8.2-3)

Display the numeric keypad screen.

The current setting value and setting range are displayed on the numeric keypad screen.

Set within the setting range.

Input the setting value, and click [OK]. (*)

Transfer the setting value to the control module QTC1-4.

(*): The setting value can also be entered from the keyboard of the host computer.

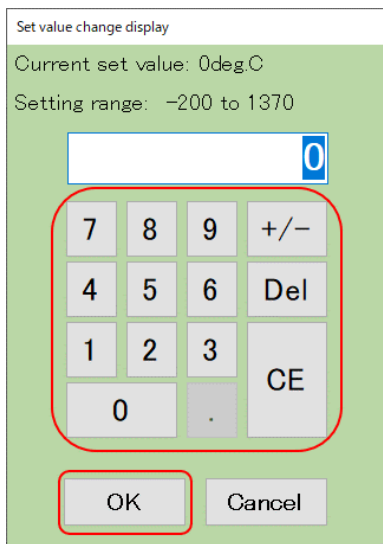

(Fig. 8.2-4)

8.2.1 Monitoring Value Setting

Display PV, output manipulated variable, state 1 reading value and state 2 reading value, and set monitor value parameters such as manual manipulated variable, sensor correction factor and sensor correction.

Click [Monitoring item] of [Main screen] tab → [Monitoring value].

Display the monitoring value screen.

The screenshot shows the QTC1 console display software interface. The window title is "QTC1 console display". The menu bar includes "File(F)", "User(U)", and "Help(H)". The status bar shows "ONLINE/OFFLINE" (green), "Device information" (QTC1-4), and "Read value from instrument" (green). The "Main screen" tab is active, and the "Monitoring value" item is selected in the left-hand menu tree.

The main display area shows a table with the following data:

Items	CH1	CH2	CH3	CH4
▶ PV reading (including difference)	32	28	29	34
MV	0.0	0.0	0.0	0.0
Heater current value	0.0	0.0	0.0	0.0
Status 1	0	0	0	0
Status 2	0	0	0	0
SV	0	0	0	0
Event input	0: OFF	0: OFF	0: OFF	0: OFF
Event output	0: OFF	0: OFF	0: OFF	0: OFF
PV reading (true value)	32	28	29	34
Manual MV setting	0.0	0.0	0.0	0.0
Sensor correction coefficient setting	1.000	1.000	1.000	1.000
Sensor correction setting	0.0	0.0	0.0	0.0
OUT bias setting	0.0	0.0	0.0	0.0
OUT gain setting	1.00	1.00	1.00	1.00

At the bottom of the screen, the "PV reading (including difference)" section displays the communication addresses for each channel:

```

Communication address :
CH1 : 03E8H
CH2 : 03E9H
CH3 : 03EAH
CH4 : 03EBH
    
```

(Fig. 8.2.1-1)

This section describes each setting item.

- Setting item
This is the setting item of control module QTC1-4.
- Channel
This is the channel number of control module QTC1-4.
- Address [HEX (Hexadecimal)]
This is the address of each channel of control module QTC1-4.
- Description, setting range and selection item
This is the description of setting item, the setting range and the selection item.
- Factory default
This is the factory shipment default value of the setting item.

Setting item	Channel	Address [HEX]	Description, setting range and selection item	Factory default
MV	CH1	0014	Set the MV for manual control.	MV when switching from automatic control to manual control
	CH2	0015	Refer to "15.2.12 Auto/Manual Control Switching (P.15-9)".	
	CH3	0016		
	CH4	0017	Setting range: -5.0 to 105.0%	
Sensor correction factor setting	CH1	0084	Set the sensor correction factor.	1.000
	CH2	0085	Set the slope of the sensor input value.	
	CH3	0086	Refer to "12.4 Correct PV (P.12-9, P.12-10)".	
	CH4	0087	Setting range: 0.000 to 10.000	
Sensor correction setting	CH1	0088	Set the sensor correction value.	When input code M is specified: 0°C (°F) When input code A, V is specified: 0
	CH2	0089	Refer to "12.4 Correct PV (P.12-9, P.12-10)".	
	CH3	008A	Setting range: -100.0 to 100.0°C	
	CH4	008B	(-180.0 to 180.0°F) -1000 to 1000 (when direct current and DC voltage input)	
Output bias setting	CH1	01C0	When the output distribution of the controlled object is known in advance, set the bias value for the reference output.	0.0%
	CH2	01C1		
	CH3	01C2		
	CH4	01C3		
Output gain setting	CH1	01C4	When the output distribution of the controlled object is known in advance, set the gain (ratio) with respect to the reference output.	1.00 times
	CH2	01C5		
	CH3	01C6		
	CH4	01C7		

8.2.2 Operation Parameters Setting

Set the operation parameters of Control Enable/Disable, AT Perform/Cancel, Event output ON/OFF, and Auto/Manual control.

Click [Monitoring item] of [Main screen] tab → [Operation setting].

Display the Operation setting screen.

The screenshot shows the QTC1 console display software interface. The main window is titled "QTC1 console display" and has a menu bar with "File(F)", "User(U)", and "Help(H)". Below the menu bar, there is a status bar with "ONLINE/OFFLINE" (green), "Device information" (QTC1-4), and "Read value from instrument" (green). The interface is divided into two main sections: "Main screen" and "Graph display".

The "Main screen" section contains a tree view on the left with the following items:

- Monitoring item
 - Monitoring value
 - Operation setting
- Normal setting
 - Control setting
 - Alarm setting
- Initial setting
 - Input setting
 - Output setting
- High function setting
 - Standard function setting
 - Extension function selection
 - Option function setting
 - Detail setting
- Error history
 - Error history
- Product information
 - Product information

The "Graph display" section contains a table with the following data:

Items	CH1	CH2	CH3	CH4
Control Allowed/Prohibited selection	0: Prohibited	0: Prohibited	0: Prohibited	0: Prohibited
AT Perform/Cancel selection	0: Cancel	0: Cancel	0: Cancel	0: Cancel
Event output ON/OFF selection	0: OFF	0: OFF	0: OFF	0: OFF
Auto/Manual selection	0: Auto con...	0: Auto con...	0: Auto con...	0: Auto con...

The bottom section of the interface shows the detailed view of the "Control Allowed/Prohibited selection" setting:

Control Allowed/Prohibited selection
Setting range :
0 : Prohibited
1 : Allowed
Default :
0 : Prohibited
Communication address :
CH1 : 0004H
CH2 : 0005H
CH3 : 0006H

(Fig. 8.2.2-1)

Setting item	Channel	Address [HEX]	Description, setting range and selection item	Factory default
Control Allowed/ Prohibited selection	CH1	0004	Select Control Allowed or Control Prohibited.	0: Prohibited
	CH2	0005	Selection item:	
	CH3	0006	0: Control Prohibited	
	CH4	0007	1: Control Allowed	
AT Perform/ Cancel selection	CH1	0008	Select AT Perform or AT Cancel.	0: Cancel
	CH2	0009	Selection item:	
	CH3	000A	0: Cancel	
	CH4	000B	1: Perform	
Event output ON/OFF selection	CH1	000C	Selects event output ON or event output OFF from the host.	0: OFF
	CH2	000D		
	CH3	000E	This setting is valid when 0 (No action) is selected in Event output allocation selection.	
	CH4	000F	Selection item: 0: OFF 1: ON	
Auto/Manual control selection	CH1	0010	Select Automatic control or Manual control.	0: Auto control
	CH2	0011	Refer to "15.2.12 Auto/Manual Control Switching (P.15-9)".	
	CH3	0012		
	CH4	0013	Selection item: 0: Auto control 1: Manual control	

8.2.3 Control Setting

Set the control parameters such as SV, SV rise rate, SV fall rate, control action and PID.

Click [Monitoring item] of [Main screen] tab → [Control setting].

Display the Control setting screen.

The screenshot shows the QTC1 console display with the following components:

- Menu Tree (Left):**
 - Monitoring item
 - Monitoring value
 - Operation setting
 - Normal setting
 - Control setting** (highlighted)
 - Alarm setting
 - Initial setting
 - Input setting
 - Output setting
 - High function setting
 - Standard function setting
 - Extension function selection
 - Option function setting
 - Detail setting
 - Error history
 - Error history
 - Product information
 - Product information

- Table (Center):**

Items	CH1	CH2	CH3	CH4
Setting value(SV)	0	0	0	0
Input difference setting	1	1	1	1
SV rise rate setting	0	0	0	0
SV fall rate setting	0	0	0	0
Control action selection	0: 2 DOF P...	0: 2 DOF P...	0: 2 DOF P...	0: 2 DOF P...
Proportional band setting	10	10	10	10
Integral time setting	200	200	200	200
Derivative time setting	50	50	50	50
Cooling proportional band setting	10		10	
Cooling integral time setting	200		200	
Cooling derivative time setting	50		50	
Overlap/Dead band setting	0.0		0.0	
Proportional gain 2 DOF coefficient (α) setting	0.40	0.40	0.40	0.40
Integral 2 DOF coefficient (β) setting	1.35	1.35	1.35	1.35
Derivative 2 DOF coefficient (γ) setting	0.00	0.00	0.00	0.00
SV proportional coefficient (C_p) setting	1.00	1.00	1.00	1.00
Gap width setting	0.0	0.0	0.0	0.0
Gap coefficient setting	1.0	1.0	1.0	1.0
MV bias setting	0.0	0.0	0.0	0.0
- Setting value (SV) Details (Bottom):**
- Setting range : Scaling low limit value to Scaling high limit value
- Default : 0
- Communication address :
 - CH1 : 0018H
 - CH2 : 0019H
 - CH3 : 001AH
 - CH4 : 001BH

(Fig. 8.2.3-1)

Setting item	Channel	Address [HEX]	Description, setting range and selection item	Factory default
SV setting	CH1 CH2 CH3 CH4	0018 0019 001A 001B	Set the SV to be controlled. Setting range: Scaling lower limit to Scaling high limit	0°C(°F)
Input difference setting	CH1 CH2 CH3 CH4	0134 0135 0136 0137	Set the value of the input difference to be detected by the input difference detection function. Setting range: 1 to 1000°C (1 to 1800°F) or 0.1 to 1000.0°C (0.1 to 1800.0°F) when Direct current and DC voltage input 1 to 10000	When input code M is specified: 1°C (°F) When input code A, V is specified: 1
SV rise rate setting	CH1 CH2 CH3 CH4	0090 0091 0092 0093	Set the rate of rise when changing SV by the set value ramp function. Refer to “15.2.9 Set Value Ramp Function (P.15-8)”. Setting range: 0 to 10000 °C/min (0 to 18000 °F/min) or 0.0 to 1000.0 °C/min (0.0 to 1800.0 °F/min) when direct current and DC voltage input 0 to 10000/min	When input code M is specified: 0 °C/min (°F/min) When input code A, V is specified: 0/min
SV fall rate setting	CH1 CH2 CH3 CH4	0094 0095 0096 0097	Set the fall of increase when changing SV by the set value ramp function. Refer to “15.2.9 Set Value Ramp Function (P.15-8)”. Setting range: 0 to 10000 °C/min (0 to 18000 °F/min) or 0.0 to 1000.0 °C/min (0.0 to 1800.0 °F/min) when direct current and DC voltage input 0 to 10000/min	When input code M is specified: 0 °C/min (°F/min) When input code A, V is specified: 0/min
Control action selection	CH1 CH2 CH3 CH4	0138 0139 013A 013B	Select the control action. This item can be selected only when Control Disable is set. Refer to “15.1 Control Action Explanation (P.15-1 to P.15-5)”. Selection item: 0: 2 DOF PID control 1: Fast-PID control 2: Slow-PID control 3: ON-OFF control 4: Gap-PID control	0: 2 DOF PID control

Setting item	Channel	Address [HEX]	Description, setting range and selection item	Factory default
Proportional band setting	CH1	001C	Set the proportional band setting.	When input code M is specified: 10 °C (18 °F) When input code A, V is specified: 2.50 %
	CH2	001D	When "1: Heating/Cooling Control" is selected in control function selection, the heating side proportional band setting is set.	
	CH3	001E		
	CH4	001F	Setting range: 1 to input span °C (°F) or 0.1 to input span °C (°F) when direct current and DC voltage input 0.10 to 100.00 % or 0.1 to 1000.0 %	
Integral time setting	CH1	0020	Set the integral time.	200 seconds
	CH2	0021	When "1: Heating/Cooling Control" is selected in control function selection, the the heating side integral time setting is set.	
	CH3	0022	The setting range varies depending on the selection of Integral/Derivative decimal point position selection.	
	CH4	0023	Setting range: 0 to 3600 seconds or 0.0 to 2000.0 seconds When select "2: Slow-PID control" of control action selection 1 to 3600 seconds or 0.1 to 2000.0 seconds	
Derivative time setting	CH1	0024	Set the derivative time.	50 seconds
	CH2	0025	When "1: Heating/Cooling Control" is selected in control function selection, the the heating side derivative time setting is set.	
	CH3	0026	The setting range varies depending on the selection of Integral/Derivative decimal point position selection.	
	CH4	0027	Setting range: 0 to 3600 seconds or 0.0 to 2000.0 seconds	
Cooling P-band setting	CH1	0194	Set the cooling proportional band.	When input code M is specified: 10 °C (18 °F) When input code A, V is specified: 2.50 %
	CH2	0195	This is valid when "1: Heating/Cooling Control" is selected in control function selection.	
	CH3	0196	Set to CH1 or CH3.	
	CH4	0197	It is disabled when set to CH2 or CH4. Setting range: 0 to input span °C (°F) or 0.0 to input span °C (°F) when direct current and DC voltage input 0.00 to 100.00 % or 0.0 to 100.0 %	

Setting item	Channel	Address [HEX]	Description, setting range and selection item	Factory default
Cooling integral time setting	CH1	0198	Set the cooling integral time setting.	200 seconds
	CH2	0199	This is valid when "1: Heating/Cooling Control" is selected in control function selection.	
	CH3	019A	Set to CH1 or CH3.	
	CH4	019B	It is disabled when set to CH2 or CH4. The setting range varies depending on the selection of Integral/Derivative decimal point position selection. Setting range: 0 to 3600 seconds or 0.0 to 2000.0 seconds when select "2: Slow-PID control" of control action selection 1 to 3600 seconds or 0.1 to 2000.0 seconds	
Cooling derivative time setting	CH1	019C	Set the cooling derivative time setting	50 seconds
	CH2	019D	This is valid when "1: Heating/Cooling Control" is selected in control function selection.	
	CH3	019E	Set to CH1 or CH3.	
	CH4	019F	It is disabled when set to CH2 or CH4. The setting range varies depending on the selection of Integral/Derivative decimal point position selection. Setting range: 0 to 3600 seconds or 0.0 to 2000.0 seconds	
Overlap/Dead band setting	CH1	01A8	Set the overlap/dead band setting.	When input code M is specified: 0.0°C (°F) When input code A, V is specified: 0
	CH2	01A9	Refer to "15.5.6 Heating/Cooling Control Operation D iagram (When Setting Dead Band) (P.15-38)" and "15.5.7 Heating/Cooling Control Operation Diagram (When Setting Overlap Band) (P.15-39)".	
	CH3	01AA	This is valid when "1: Heating/Cooling Control" is selected in control function selection.	
	CH4	01AB	Set to CH1 or CH3. It is disabled when set to CH2 or CH4. Setting range: -100.0 to 100.0°C (-180.0 to 180.0°F) when direct current and DC voltage input -1000 to 1000	

Setting item	Channel	Address [HEX]	Description, setting range and selection item	Factory default
Proportional gain 2 DOF coefficient (α) setting	CH1	013C	Set the proportional gain 2 DOF coefficient (α) setting. Refer to "15.1.1 2 DOF PID Control (P.15-2)". When select "1: Fast-PID control", "2: Slow-PID control", "3: ON-OFF control", or "4: Gap-PID control" in control action, do not change this setting item. Setting range: 0.00 to 1.00	0.40
	CH2	013D		
	CH3	013E		
	CH4	013F		
Integral 2 DOF coefficient (β) setting	CH1	0140	Set the integral 2 DOF coefficient (β) setting. Refer to "15.1.1 2 DOF PID Control (P.15-2)". When select "1: Fast-PID control", "2: Slow-PID control", "3: ON-OFF control", or "4: Gap-PID control" in control action, do not change this setting item. Setting range: 0.00 to 10.00	1.35
	CH2	0141		
	CH3	0142		
	CH4	0143		
Derivative 2 DOF coefficient (γ , Cd) setting	CH1	0144	Set the derivative 2-DOF coefficient (γ , Cd) setting. Do not change this setting item. Setting range: 0.00 to 1.00	0.00
	CH2	0145		
	CH3	0146		
	CH4	0147		
Desired value proportional coefficient (C_p) setting	CH1	0148	Set the desired value proportional coefficient (C_p) setting. Do not change this setting item. Setting range: 0.00 to 1.00	1.00
	CH2	0149		
	CH3	014A		
	CH4	014B		
Gap width setting	CH1	014C	Set the gap width setting. Proportional band \times Gap width Setting range: 0.0 to 10.0%	0.0%
	CH2	014D		
	CH3	014E		
	CH4	014F		
Gap coefficient setting	CH1	0150	Set the gap coefficient setting. Setting range: 0.0 to 1.0	1.0
	CH2	0151		
	CH3	0152		
	CH4	0153		
MV bias setting	CH1	0098	Set the MV bias setting. Refer to "15.2.4 MV Bias (P.15-6)". Setting range: 0.0 to 100.0%	0.0%
	CH2	0099		
	CH3	009A		
	CH4	009B		

8.2.4 Alarm Parameters Setting

Set the alarm parameters such as Alarm 1 to 4 type selection, Alarm 1 to 4 setting and Alarm 1 to 4 hysteresis setting.

Click [Normal setting] of [Main screen] tab → [Alarm setting].

Display the Alarm setting screen.

The screenshot shows the QTC1 console display software interface. The main window is titled "QTC1 console display" and includes a menu bar (File(F), User(U), Help(H)), a status bar (ONLINE/OFFLINE, Device information: QTC1-4, Read value from instrument), and tabs for "Main screen" and "Graph display".

The left sidebar contains a tree view of settings:

- Monitoring item
 - Monitoring value
 - Operation setting
- Normal setting
 - Control setting
 - Alarm setting (highlighted)
- Initial setting
 - Input setting
 - Output setting
- High function setting
 - Standard function setting
 - Extension function selection
 - Option function setting
 - Detail setting
- Error history
 - Error history
- Product information
 - Product information

The main area displays a table of alarm parameters:

Items	CH1	CH2	CH3	CH4
Alarm 1 type selection	0: No action	0: No action	0: No action	0: No action
Alarm 2 type selection	0: No action	0: No action	0: No action	0: No action
Alarm 3 type selection	0: No action	0: No action	0: No action	0: No action
Alarm 4 type selection	0: No action	0: No action	0: No action	0: No action
Alarm 1 hysteresis setting	1.0	1.0	1.0	1.0
Alarm 2 hysteresis setting	1.0	1.0	1.0	1.0
Alarm 3 hysteresis setting	1.0	1.0	1.0	1.0
Alarm 4 hysteresis setting	1.0	1.0	1.0	1.0
Alarm 1 setting	0	0	0	0
Alarm 1 high limit setting	0	0	0	0
Alarm 2 setting	0	0	0	0
Alarm 2 high limit setting	0	0	0	0
Alarm 3 setting	0	0	0	0
Alarm 3 high limit setting	0	0	0	0
Alarm 4 setting	0	0	0	0
Alarm 4 high limit setting	0	0	0	0
Loop break alarm band setting	0	0	0	0
Loop break alarm time setting	0	0	0	0

The bottom section shows the detailed view for "Alarm 1 type selection":

Alarm 1 type selection
 Setting range :
 0 : No action
 1 : High limit alarm
 2 : Low limit alarm
 3 : High/Low limits alarm
 4 : High/Low limit range alarm
 5 : Process high alarm
 6 : Process low alarm
 7 : High limit with standby alarm

(Fig. 8.2.4-1)

Setting item	Channel	Address [HEX]	Description, setting range and selection item	Factory default
Alarm 1 action selection	CH1	0038	Select the alarm 1 action.	0: No action
	CH2	0039	Refer to “15.5.3 Alarm Operation Diagram (P.15-34, P.15-35)”.	
	CH3	003A		
	CH4	003B	Selection item: 0: No action 1: High limit alarm 2: Low limit alarm 3: High/Low limits alarm 4: High/Low limits range 5: Process High alarm 6: Process low alarm 7: High limit with standby 8: Low limit with standby 9: High/Low limits alarm with 10: High/Low limits alarm individually 11: High/Low limits range alarm individually 12: High/Low limits alarm with standby individually	
Alarm 2 action selection	CH1	003C	Select the alarm 2 action.	0: No action
	CH2	003D	Refer to “15.5.3 Alarm Operation Diagram (P.15-34, P.15-35)”.	
	CH3	003E		
	CH4	003F	Selection item: 0: No action 1: High limit alarm 2: Low limit alarm 3: High/Low limits alarm 4: High/Low limits range 5: Process High alarm 6: Process low alarm 7: High limit with standby 8: Low limit with standby 9: High/Low limits alarm with 10: High/Low limits alarm individually 11: High/Low limits range alarm individually 12: High/Low limits alarm with standby individually	

Setting item	Channel	Address [HEX]	Description, setting range and selection item	Factory default
Alarm 3 action selection	CH1	0040	Select the alarm 3 action.	0: No action
	CH2	0041	Refer to “15.5.3 Alarm Operation Diagram (P.15-34, P.15-35)”.	
	CH3	0042		
	CH4	0043	Selection item: 0: No action 1: High limit alarm 2: Low limit alarm 3: High/Low limits alarm 4: High/Low limits range 5: Process High alarm 6: Process low alarm 7: High limit with standby 8: Low limit with standby 9: High/Low limits alarm with 10: High/Low limits alarm individually 11: High/Low limits range alarm individually 12: High/Low limits alarm with standby individually	
Alarm 4 action selection	CH1	0044	Select the alarm 4 action.	0: No action
	CH2	0045	Refer to “15.5.3 Alarm Operation Diagram (P.15-34, P.15-35)”.	
	CH3	0046		
	CH4	0047	Selection item: 0: No action 1: High limit alarm 2: Low limit alarm 3: High/Low limits alarm 4: High/Low limits range 5: Process High alarm 6: Process low alarm 7: High limit with standby 8: Low limit with standby 9: High/Low limits alarm with 10: High/Low limits alarm individually 11: High/Low limits range alarm individually 12: High/Low limits alarm with standby individually	

Setting item	Channel	Address [HEX]	Description, setting range and selection item	Factory default
Alarm 1 hysteresis setting	CH1	0048	Set the alarm 1 hysteresis setting.	When input code M is specified: 10°C (18°F) When input code A, V is specified: 10
	CH2	0049	Refer to “15.5.3 Alarm Operation Diagram (P.15-34, P.15-35)”.	
	CH3	004A		
	CH4	004B	Setting range: 0.1 to 1000.0°C (0.1 to 1800.0°F) when direct current and DC voltage input 1 to 10000	
Alarm 2 hysteresis setting	CH1	004C	Set the alarm 2 hysteresis setting.	When input code M is specified: 10°C (18°F) When input code A, V is specified: 10
	CH2	004D	Refer to “15.5.3 Alarm Operation Diagram (P.15-34, P.15-35)”.	
	CH3	004E		
	CH4	004F	Setting range: 0.1 to 1000.0°C (0.1 to 1800.0°F) when direct current and DC voltage input 1 to 10000	
Alarm 3 hysteresis setting	CH1	0050	Set the alarm 3 hysteresis setting.	When input code M is specified: 10°C (18°F) When input code A, V is specified: 10
	CH2	0051	Refer to “15.5.3 Alarm Operation Diagram (P.15-34, P.15-35)”.	
	CH3	0052		
	CH4	0053	Setting range: 0.1 to 1000.0°C (0.1 to 1800.0°F) when direct current and DC voltage input 1 to 10000	
Alarm 4 hysteresis setting	CH1	0054	Set the alarm 4 hysteresis setting.	When input code M is specified: 10°C (18°F) When input code A, V is specified: 10
	CH2	0055	Refer to “15.5.3 Alarm Operation Diagram (P.15-34, P.15-35)”.	
	CH3	0056		
	CH4	0057	Setting range: 0.1 to 1000.0°C (0.1 to 1800.0°F) when direct current and DC voltage input 1 to 10000	
Alarm 1 value setting	CH1	0058	Set the alarm 1 value setting.	When input code M is specified: 0°C (°F) When input code A, V is specified: 0
	CH2	0059	Refer to “15.5.3 Alarm Operation Diagram (P.15-34, P.15-35)”.	
	CH3	005A		
	CH4	005B	When High/Low limits alarm individually, High/Low limits range alarm individually or High/Low limits alarm with standby individually is selected in Alarm 1 action selection, the lower limit value of alarm 1 is set. Setting range: Refer to “Alarm 1 to 4 value setting range table (P.8-22)”.	

Setting item	Channel	Address [HEX]	Description, setting range and selection item	Factory default
Alarm 1 high limit value setting	CH1	005C	Set the alarm 1 high limit value setting.	When input code M is specified: 0°C (°F) When input code A, V is specified: 0
	CH2	005D	Refer to “15.5.3 Alarm Operation Diagram (P.15-34, P.15-35)”.	
	CH3	005E	When High/Low limits alarm individually, High/Low limits s range alarm individually or High/Low limits alarm with standby individually is selected in Alarm 1 action selection, this setting is valid Setting range: Refer to “Alarm 1 to 4 value setting range table (P.8-22)”.	
	CH4	005F		
Alarm 2 value setting	CH1	0060	Set the alarm 2 value setting.	When input code M is specified: 0°C (°F) When input code A, V is specified: 0
	CH2	0061	Refer to “15.5.3 Alarm Operation Diagram (P.15-34, P.15-35)”.	
	CH3	0062	When High/Low limits alarm individually, High/Low limits s range alarm individually or High/Low limits alarm with standby individually is selected in Alarm 2 action selection, the lower limit value of alarm 2 is set. Setting range: Refer to “Alarm 1 to 4 value setting range table (P.8-22)”.	
	CH4	0063		
Alarm 2 high limit value setting	CH1	0064	Set the alarm 2 high limit value setting.	When input code M is specified: 0°C (°F) When input code A, V is specified: 0
	CH2	0065	Refer to “15.5.3 Alarm Operation Diagram (P.15-34, P.15-35)”.	
	CH3	0066	When High/Low limits alarm individually, High/Low limits s range alarm individually or High/Low limits alarm with standby individually is selected in Alarm 2 action selection, this setting is valid Setting range: Refer to “Alarm 1 to 4 value setting range table (P.8-22)”.	
	CH4	0067		
Alarm 3 value setting	CH1	0068	Set the alarm 3 value setting.	When input code M is specified: 0 °C (°F) When input code A, V is specified: 0
	CH2	0069	Refer to “15.5.3 Alarm Operation Diagram (P.15-34, P.15-35)”.	
	CH3	006A	When High/Low limits alarm individually, High/Low limits s range alarm individually or High/Low limits alarm with standby individually is selected in Alarm 3 action selection, the lower limit value of alarm 3 is set. Setting range: Refer to “Alarm 1 to 4 value setting range table (P.8-22)”.	
	CH4	006B		

Setting item	Channel	Address [HEX]	Description, setting range and selection item	Factory default
Alarm 3 high limit value setting	CH1	006C	Set the alarm 3 high limit value setting.	When input code M is specified: 0°C (°F) When input code A, V is specified: 0
	CH2	006D	Refer to “15.5.3 Alarm Operation Diagram (P.15-34, P.15-35)”.	
	CH3	006E	When High/Low limits alarm individually, High/Low limits s range alarm individually or High/Low limits alarm with standby individually is selected in Alarm 3 action selection, this setting is valid Setting range: Refer to “Alarm 1 to 4 value setting range table (P.8-22)”.	
	CH4	006F		
Alarm 4 value setting	CH1	0070	Set the alarm 4 value setting.	When input code M is specified: 0°C (°F) When input code A, V is specified: 0
	CH2	0071	Refer to “15.5.3 Alarm Operation Diagram (P.15-34, P.15-35)”.	
	CH3	0072	When High/Low limits alarm individually, High/Low limits s range alarm individually or High/Low limits alarm with standby individually is selected in Alarm 4 action selection, the lower limit value of alarm 4 is set. Setting range: Refer to “Alarm 1 to 4 value setting range table (P.8-22)”.	
	CH4	0073		
Alarm 4 high limit value setting	CH1	0074	Set the alarm 4 high limit value setting.	When input code M is specified: 0°C (°F) When input code A, V is specified: 0
	CH2	0075	Refer to “15.5.3 Alarm Operation Diagram (P.15-34, P.15-35)”.	
	CH3	0076	When High/Low limits alarm individually, High/Low limits s range alarm individually or High/Low limits alarm with standby individually is selected in Alarm 4 action selection, this setting is valid Setting range: Refer to “Alarm 1 to 4 value setting range table (P.8-22)”.	
	CH4	0077		
Loop break alarm band setting	CH1	007C	Set the alarm band for judging loop break.	When input code M is specified: 0°C (°F) When input code A, V is specified: 0
	CH2	007D	Refer to “15.2.8 Loop Break Alarm (P.15-8)”.	
	CH3	007E	Setting range: 0 to 150°C (0 to 270°F) or 0.0 to 150.0°C (0.0 to 270.0°F) when direct current and DC voltage input 0 to 1500	
	CH4	007F		
Loop break alarm time setting	CH1	0080	Set the alarm time for judging loop break.	0 minutes
	CH2	0081	Refer to “15.2.8 Loop Break Alarm (P.15-8)”.	
	CH3	0082	Setting range: 0 to 200 minutes	
	CH4	0083		

Alarm 1 to 4 value setting range table

Alarm action	Setting range
No action	
High limit alarm	-(Input span) to Input span (*1)
Lowh limit alarm	-(Input span) to Input span (*1)
High/Low limits alarm	0 to Input span (*1)
High/Low limit s range	0 to Input span (*1)
Process High alarm	Input range lower limit to Input range high limit (*2)
Process low alarm	Input range lower limit to Input range high limit (*2)
High limit with standby	-(Input span) to Input span (*1)
Low limit with standby	-(Input span) to Input span (*1)
High/Low limits alarm with	0 to Input span (*1)
High/Low limits alarm individually	0 to Input span (*1)
High/Low limit s range alarm individually	0 to Input span (*1)
High/Low limits alarm with standby individually	0 to Input span (*1)

(*1): When direct current input and DC voltage input, the input span is the scaling width.

(*2): When direct current input and DC voltage input, the Input range lower limit is the scaling lower limit, and the Input range high limit is the scaling high limit.

8.2.5 Input Setting

Set the input parameters such as input type, temperature unit and input sampling cycle.

Click [Initial setting] of [Main screen] tab → [Input setting].

Display the Input setting screen.

The screenshot shows the QTC1 console display interface. The top bar indicates the device is 'ONLINE/OFFLINE' and shows 'Device information' as 'QTC1-4'. The main screen is divided into a left sidebar with a tree view and a central table.

The tree view on the left includes categories like 'Monitoring item', 'Normal setting', 'Initial setting', 'High function setting', 'Error history', and 'Product information'. The 'Initial setting' category is expanded, and 'Input setting' is selected.

The central table displays the following settings:

Items	CH1	CH2	CH3	CH4
Input type selection	0: K -200 t...	0: K -200 t...	0: K -200 t...	0: K -200 t...
Input math function selection	0: Standard	0: Standard	0: Standard	0: Standard
Input difference selection	0: Disabled	0: Disabled	0: Disabled	0: Disabled
Temperature unit selection	0: deg.C	0: deg.C	0: deg.C	0: deg.C
Scaling high limit setting	1370	1370	1370	1370
Scaling low limit setting	-200	-200	-200	-200
Input sampling selection	0: 125ms	0: 125ms	0: 125ms	0: 125ms
PV filter setting	0.0	0.0	0.0	0.0
Number of moving average setting	1	1	1	1

Below the table, the 'Input type selection' setting is detailed:

Input type selection
 Setting range :
 For input M :
 For temperature unit selection = deg.C :
 0 : K -200 to 1370 deg.C
 1 : K -200.0 to 400.0 deg.C
 2 : J -200 to 1000 deg.C
 3 : R 0 to 1760 deg.C
 4 : S 0 to 1760 deg.C
 5 : R 0 to 1820 deg.C

(Fig. 8.2.5-1)

Setting item	Channel	Address [HEX]	Description, setting range and selection item	Factory default
Input type selection (When input code M is specified)	CH1	00C8	Select the input type.	0: K -200 to 1370°C
	CH2	00C9	Selection item:	
	CH3	00CA	0: K -200 to 1370°C	
	CH4	00CB	1: K -200.0 to 400.0°C	
			2: J -200 to 1000°C	
			3: R 0 to 1760°C	
			4: S 0 to 1760°C	
			5: B 0 to 1820°C	
			6: E -200 to 800°C	
			7: T -200.0 to 400.0°C	
			8: N -200 to 1300°C	
			9: PL-II 0 to 1390°C	
			10: C(W/Re5-26) 0 to 2315°C	
			11: Pt100 -200.0 to 850.0°C	
			12: 0 to 1 V DC -32768 to 32767	
			13: 4 to 20 mA DC (Externally mounted shunt resistor) -32768 to 32767	
			14: 0 to 20 mA DC (Externally mounted shunt resistor) -32768 to 32767	
Input type selection (When input code A is specified)	CH1	00C8	Select the input type.	0: 4 to 20 mA DC (Built in shunt resistor)
	CH2	00C9	Selection item:	
	CH3	00CA	0: 4 to 20 mA DC (Built in shunt resistor) -32768 to 32767	
	CH4	00CB	1: 0 to 20 mA DC (Built in shunt resistor) -32768 to 32767	
Input type selection (When input code V is specified)	CH1	00C8	Select the input type.	0: 0 to 5 V DC -32768 to 32767
	CH2	00C9	Selection item:	
	CH3	00CA	0: 0 to 5 V DC -32768 to 32767	
	CH4	00CB	1: 1 to 5 V DC -32768 to 32767	
			2: 0 to 10 V DC -32768 to 32767	
Input math function selection	CH1	012C	Select the input math function.	0: Standard
	CH2	012D	Refer to "15.3.3 Input Math Function (P.15-26)".	
	CH3	012E	Selection item:	
	CH4	012F	0: Standard	
			1: Difference input [(CH1-CH2) or (CH3-CH4)](*)	
		2: Addition input [(CH1+CH2) or (CH3+CH4)](*)		
		(*): Select CH1 or CH3 for differential input and addition input. It is disabled when set with CH2 or CH4.		

Setting item	Channel	Address [HEX]	Description, setting range and selection item	Factory default
Input difference selection	CH1	0130	Select the channel for which the input difference detection function detects the input difference from the local channel. Selection item: 0: Disable 1: CH1 2: CH2 3: CH3 4: CH4	0: Disable
	CH2	0131		
	CH3	0132		
	CH4	0133		
Temperature unit selection	CH1	00CC	Select the temperature unit. Valid when input code M is specified. Selection item: 0: deg. C 1: deg. F	0: deg. C
	CH2	00CD		
	CH3	00CE		
	CH4	00CF		
Scaling high limit setting (*)	CH1	00D0	Set the scaling high limit. Setting range: Scaling low limit to Rated high limit	Rated high limit When direct current input or DC voltage input is used 10000
	CH2	00D1		
	CH3	00D2		
	CH4	00D3		
Scaling low limit setting (*)	CH1	00D4	Set the scaling low limit. Setting range: Rated low limit to Scaling high limit	Rated low limit When direct current input or DC voltage input is used -2000
	CH2	00D5		
	CH3	00D6		
	CH4	00D7		
Input sampling selection	CH1	00D8	Select the input sampling cycle. Selection item: 0: 125 ms 1: 50 ms 2: 20 ms It is fixed at 125 ms for thermocouple input and RTD input. If select a value other than 125 ms, it will be invalid.	125 ms
	CH2	00D9		
	CH3	00DA		
	CH4	00DB		
PV filter time constant setting	CH1	008C	Set the PV filter time constant. Refer to "15.4.4 PV Filter Time Constant (P.15-28)". Setting range: 0.0 to 10.0 seconds	0.0 seconds
	CH2	008D		
	CH3	008E		
	CH4	008F		
Number of moving average setting	CH1	0108	Set the number of moving averages that average the input values. The input values are averaged the set number of times, and the input values are exchanged every input sampling cycle. If set 1 time, the moving average will not be performed. Setting range: 1 to 10 times	1 time
	CH2	0109		
	CH3	010A		
	CH4	010B		

(*): For thermocouple input and RTD input, the scaling high limit is the SV high limit and the scaling low limit is the SV low limit.

When the scaling high limit value and scaling low limit value are set to the same value, the control output turns OFF.

8.2.6 Output Setting

Set the output parameters such as direct/reverse action, proportional cycle and ON/OFF hysteresis.

Click [Monitoring item] of [Initial screen] tab → [Output setting].

Display the Output setting screen.

The screenshot shows the QTC1 console display interface. At the top, there is a status bar with 'ONLINE/OFFLINE' and 'Device information QTC1-4'. Below this is a navigation menu with 'Main screen' and 'Graph display'. The left sidebar contains a tree view of settings, with 'Output setting' selected under 'Initial setting'. The main area displays a table of settings for four channels (CH1, CH2, CH3, CH4). The 'Direct/Reverse action selection' row is highlighted in blue. Below the table, a detailed view of the 'Direct/Reverse action selection' setting is shown, including its setting range (0: Reverse action, 1: Direct action) and default value (0: Reverse action).

Items	CH1	CH2	CH3	CH4
Direct/Reverse action selection	0: Reverse ...	0: Reverse ...	0: Reverse ...	0: Reverse ...
Proportional cycle setting	30.0	30.0	30.0	30.0
ON/OFF hysteresis setting	1.0	1.0	1.0	1.0
Cooling proportional cycle setting	30.0		30.0	
Cooling ON/OFF hysteresis setting	1.0		1.0	
Output minimum ON/OFF time setting	0	0	0	0
OUT rate-of change setting	0.00	0.00	0.00	0.00
Control action selection when input error	0: Output ...	0: Output ...	0: Output ...	0: Output ...
Output manipulated variable setting when input error	0.0	0.0	0.0	0.0

Direct/Reverse action selection
Setting range :
0 : Reverse action
1 : Direct action
Default :
0 : Reverse action
Communication address :
CH1 : 00DCH
CH2 : 00DDH
CH3 : 00DFH

(Fig. 8.2.6-1)

Setting item	Channel	Address [HEX]	Description, setting range and selection item	Factory default
Direct/ Reverse action selection	CH1	00DC	Select the direct action or reverse action.	0: Reverse action
	CH2	00DD	Selection item:	
	CH3	00DE	0: Reverse action	
	CH4	00DF	1: Direct action	
Proportional cycle setting	CH1	0028	Set the proportional cycle.	Relay contact output: 30.0 seconds Non-contact voltage output, open collector output: 3.0 seconds DC current output, DC voltage output: None
	CH2	0029	When "1: Heating/Cooling Control" is selected	
	CH3	002A	in control function selection, the heating side	
	CH4	002B	proportional band setting is set. Setting range: 0.1 to 100.0 seconds	
ON/OFF hysteresis setting	CH1	002C	Set the ON/OFF hysteresis.	When input code M is specified: 1.0°C (1.8°F) When input code A, V is specified: 10
	CH2	002D	When "1: Heating/Cooling Control" is selected	
	CH3	002E	in control function selection, the heating side	
	CH4	002F	ON/OFF hysteresis setting is set. Setting range: 0.1 to 1000.0°C (0.1 to 1800.0°F) when direct current and DC voltage input 1 to 10000	
Cooling proportional cycle setting	CH1	01A0	Set the cooling proportional cycle.	Relay contact output: 30.0 seconds Non-contact voltage output, open collector output: 3.0 seconds DC current output, DC voltage output: None
	CH2	01A1	This is valid when "1: Heating/Cooling	
	CH3	01A2	Control" is selected in control function	
	CH4	01A3	selection. Set to CH1 or CH3. It is disabled when to with CH2 or CH4. Setting range: 0.1 to 100.0 seconds	

Setting item	Channel	Address [HEX]	Description, setting range and selection item	Factory default
Cooling ON/OFF hysteresis setting	CH1	01A4	Set the cooling ON/OFF hysteresis.	When input code M is specified: 1.0°C (1.8°F) When input code A, V is specified: 10
	CH2	01A5	This is valid when "1: Heating/Cooling Control" is selected in control function selection.	
	CH3	01A6	Set to CH1 or CH3.	
	CH4	01A7	It is disabled when set to CH2 or CH4. Setting range: 0.1 to 1000.0°C (0.1 to 1800.0°F) when direct current and DC voltage input 1 to 10000	
Output minimum ON/OFF time setting	CH1	0154	Set the time to turn the output on or off without depending on the MV.	0 ms
	CH2	0155	Refer to "15.2.6 Output Minimum ON/OFF Time (P.15-11)".	
	CH3	0156	Setting range: 0 to 1000 ms	
	CH4	0157		
Output rate-of change setting	CH1	01CC	Set the output change rate limit.	0.00 %/seconds
	CH2	01CD	Refer to "15.2.15 Output Rate-of Change Limit (P.15-11)".	
	CH3	01CE	Setting range: 0.00 to 100.00 %/seconds	
	CH4	01CF		
Control action selection when input error	CH1	01D0	Selects the control action to be taken in the event of an input error.	0: Operation amount set value at input error
	CH2	01D1	Refer to "15.2.5 Selection of Action at Input Error (P.15-6)".	
	CH3	01D2	Selection item: 0: Operation amount set value at input error	
	CH4	01D3	1: Control operation continued	
Output manipulated variable setting when input error	CH1	01D4	Sets the output operation amount in the event of an input error.	0.0 %
	CH2	01D5	Refer to "15.2.5 Selection of Action at Input Error (P.15-6)".	
	CH3	01D6	Setting range: 0.0 to 100.0 % when direct current and DC voltage input -5.0 to 105.0 %	
	CH4	01D7		

8.2.7 Standard Function Setting

Set the standard function parameters such as control function and cooling action mode.

Click [High function setting] of [Main screen] tab → [Standard function setting].

Display the Standard function setting screen.

The screenshot shows the QTC1 console display interface. At the top, there is a status bar with 'ONLINE/OFFLINE', 'Device information', 'QTC1-4', and 'Read value from instrument'. Below this is a navigation bar with 'Main screen' and 'Graph display' tabs. A tree view on the left lists various settings, with 'Standard function setting' highlighted under 'High function setting'. The main area displays a table of settings for four channels (CH1-CH4).

Items	CH1	CH2	CH3	CH4
Control function selection	0: Standard	0: Standard	0: Standard	0: Standard
Cooling action mode selection	0: Air cooling		0: Air cooling	
Slave scale high limit setting	1370		1000	
Slave scale low limit setting	-200		-200	

Below the table, the 'Control function selection' setting is expanded, showing the following details:

Control function selection
Setting range :
For CH1, CH3 :
0 : Standard
1 : Heat cooling control
2 : Cascade control
3 : Output selection function
For CH2, CH4 :
0 : Standard
1 : Unused

(Fig. 8.2.7-1)

Setting item	Channel	Address [HEX]	Description, setting range and selection item	Factory default
Control function selection	CH1	0190	Select the control function.	0: Standard
	CH2	0191	This can be selected only when control is prohibited.	
	CH3	0192	Refer to "15.2.16 Control Function (P.15-12 to P.15-16)". Selection item: 0: Standard 1: Heating/Cooling control (*) 2: Cascade control (*) 3: Output selection function (*): Select CH1 or CH3 for heating/cooling control and cascade control. If these are selected for CH2 or CH4, they are invalid.	
	CH4	0193		
Cooling action mode selection	CH1	01B4	Select the cooling action mode.	0: Air cooling
	CH2	01B5	Refer to "Heating/Cooling control (P.15-12, P.15-13)".	
	CH3	01B6	This is valid when "1: Heating/Cooling Control" is selected in control function selection. Set to CH1 or CH3. It is disabled when set to CH2 or CH4. Selection item: 0: Air cooling (Linear characteristics) 1: Oil cooling (1.5th power of the linear characteristics) 2: Water cooling (2nd power of the linear characteristics)	
	CH4	01B7		
Slave scale high limit setting	CH1	01B8	Set the slave scale high limit of cascade control.	Slave input range high limit
	CH2	01B9	Refer to "Cascade control (P.15-13, P.15-14)".	
	CH3	01BA	Set to CH1 or CH3.	
	CH4	01BB	It is disabled when set to CH2 or CH4. Setting range: Slave scale low limit to Slave input range high limit	
Slave scale low limit setting	CH1	01BC	Set the slave scale low limit of cascade control.	Slave input range low limit
	CH2	01BD	Refer to "Cascade control (P.15-13, P.15-14)".	
	CH3	01BE	Set to CH1 or CH3.	
	CH4	01BF	It is disabled when set to CH2 or CH4. Setting range: Slave input range low limit to Slave scale high limit to	

8.2.8 Extension Function Selection

Select the extension function parameters such as extension function, auto balance control enabled/disabled and number of communication management module.

Click [High function setting] of [Main screen] tab → [Extension function selection].

Display the Extension function selection screen.

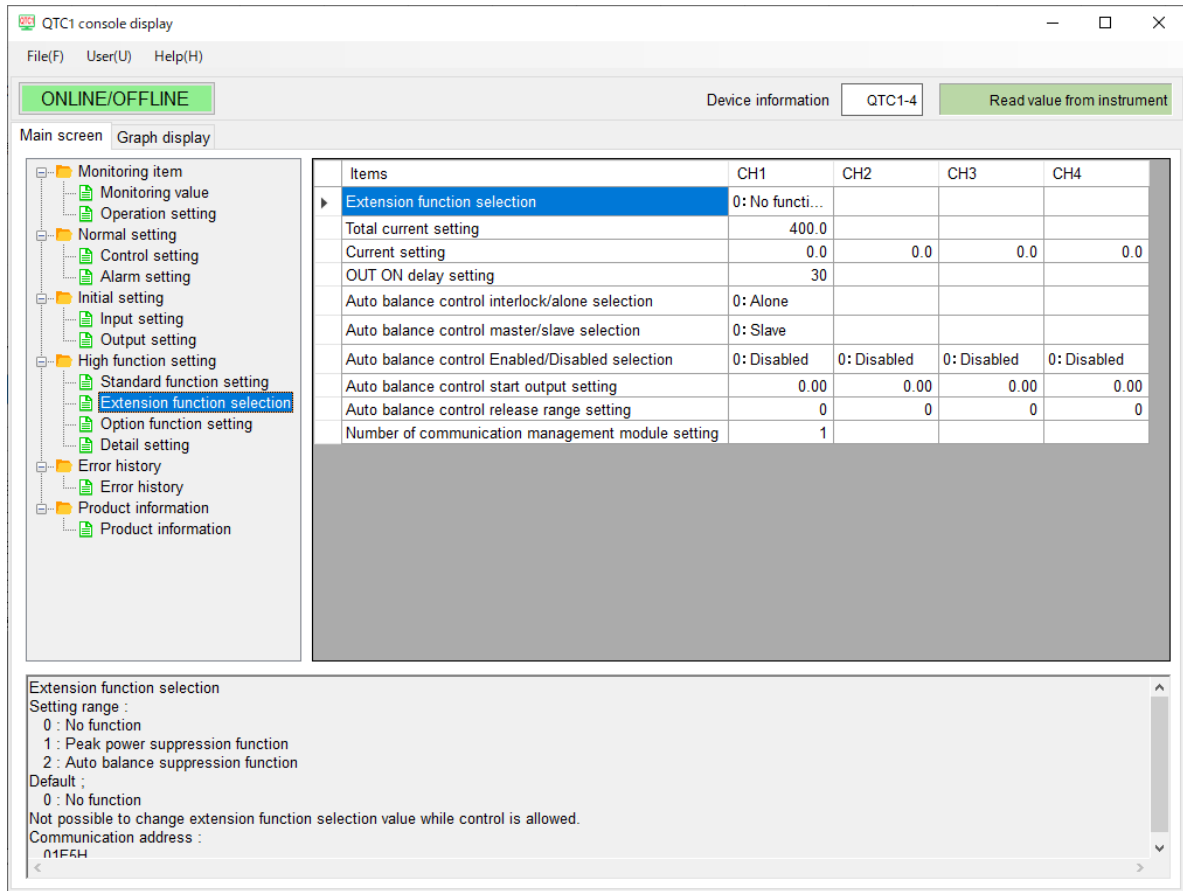

(Fig. 8.2.8-1)

Setting item	Channel	Address [HEX]	Description, setting range and selection item	Factory default
Extension function selection		01F5	Select the extension function. Refer to “15.3.1 Extension Function Selection (P.15-17 to P.15-24)”. Selection item: 0: No function 1: Peak power suppression function 2: Auto balance control function	0: No function
Total current setting		01F6	Set the total current. Refer to “Peak power suppression function (P.15-17, P.15-18)”. Setting range: 0.0 to 400.0 A	400.0 A
Current value setting	CH1 CH2 CH3 CH4	01F7 01F8 01F9 01FA	Set the current value for each channel. Refer to “Peak power suppression function (P.15-17, P.14-18)”. Setting range: 0.0 to 100.0 A	0.0 A
Output ON delay setting		01FB	Set the output ON delay. Refer to “Peak power suppression function (P.15-17, P.14-18)”. Setting range: 0 to 100 ms	30 ms
Auto balance control Interlock/ Single selection		01FC	Select whether to use the auto balance control function in conjunction with each other or individually. Refer to “Auto balance control function (P.15-18 to P.15-24)”. Selection item: 0: Single 1: Interlock	0: Single
Auto balance control Master/ Slave selection		01FD	Select whether to use the autobalance control function as a master or a slave. Refer to “Auto balance control function (P.15-18 to P.15-24)”. Selection item: 0: Slave channel 1: CH1 master channel 2: CH2 master channel 3: CH3 master channel 4: CH4 master channel	0: Slave

Setting item	Channel	Address [HEX]	Description, setting range and selection item	Factory default
Auto balance control Enabled/ Disabled selection	CH1 CH2 CH3 CH4	01FE 01FF 0200 0201	Select whether to enable or disable the auto balance control function for each channel. Refer to "Auto balance control function (P.15-18 to P.15-24)". Selection item: 0: Disabled 1: Enabled	0: Disabled
Auto balance control start output setting	CH1 CH2 CH3 CH4	0202 0203 0204 0205	Set the MV when auto balance control starts. Refer to "Auto balance control function (P.15-18 to P.15-24)". Setting range: 0.00 to 1.00 (corresponds to 0 to 100 %)	0.00 (0 %)
Auto balance control cancel area setting	CH1 CH2 CH3 CH4	0206 0207 0208 0209	Set the area to cancel the auto balance control function. When set to 0, the auto balance control cancel area is twice the proportional band of the master channel. Refer to "Auto balance control function (P.15-18 to P.15-24)". Setting range: 0 to Input span °C (°F) × 10 % or 0.0 to Input span °C (°F) × 10 % when direct current and DC voltage input 0 to Scaling width × 10 %	When input code M is specified: 0°C (°F) When input code A, V is specified: 0
Number of communication management module setting		020A	Set the number of modules managed by the master module when using the SIF function or auto balance control function. Refer to "13 Communication with PLC Using SIF Function (P.13-1 to P.13-36)" or "Auto balance control function (P.15-18 to P.15-24)". Setting range: 1 to 16 modules Set the number of modules including the master module. (Example) If two slave modules are connected, set them to three.	1 module

8.2.9 Option Function Setting

Set the option function parameters such as heater burnout alarm and event input/output allocation.

Click [High function setting] of [Main screen] tab → [Option function setting].

Display the Option function setting screen.

The screenshot shows the QTC1 console display interface. At the top, there is a status bar with 'ONLINE/OFFLINE' and 'Device information QTC1-4'. Below this, there are tabs for 'Main screen' and 'Graph display'. A tree view on the left shows the navigation structure, with 'Option function setting' selected under 'High function setting'. The main area displays a table of settings:

Items	CH1	CH2	CH3	CH4
Heater burnout alarm setting	0.0	0.0	0.0	0.0
Communication response delay time setting	0			
Event output allocation selection	0: No action	0: No action	0: No action	0: No action
Event input allocation selection	0: No action	0: No action	0: No action	0: No action

Below the table, the 'Heater burnout alarm setting' is expanded, showing the following details:

- Setting range :
 - 0.0 to 20.0A (Option 2)
 - 0.0 to 100.0A (Option A)
- Default :
 - 0.0A
- Communication address :
 - CH1 : 0078H
 - CH2 : 0079H
 - CH3 : 007AH

(Fig. 8.2.9-1)

Setting item	Channel	Address [HEX]	Description, setting range and selection item	Factory default
Heater burnout alarm setting	CH1 CH2 CH3 CH4	0078 0079 007A 007B	<p>Set the heater current value to judge the heater burnout.</p> <p>When the heater current value (CT input current) falls below the heater burnout alarm setting value, the heater burnout alarm is activated, and when it exceeds the heater burnout alarm setting value, the heater burnout alarm is released.</p> <p>The heater current value is updated when the control output is ON.</p> <p>When the control output is OFF, the heater current value when the previous control output was ON is stored.</p> <p>Set a value that is approximately 80% of the heater current value in consideration of fluctuations in the power supply voltage.</p> <p>If 0.0 is set, the heater burnout alarm will not be done.</p> <p>Refer to “15.5.4 Heater Burnout Alarm Operation Diagram (P.15-36)”.</p> <p>Setting range: when select 20 A: 0.0 to 20.0 A when select 100 A: 0.0 to 100.0 A</p>	0.0 A
Communication response delay time setting		01F4	<p>Set the delay time for returning a response after receiving a command from the host.</p> <p>When connecting to the communication expansion module QMC1-C□, set the communication response delay time to 0 ms (initial value).</p> <p>Setting range: 0 to 1000 ms</p>	0 ms

Setting item	Channel	Address [HEX]	Description, setting range and selection item	Factory default
Event output allocation selection	CH1	00FC	Select the event output allocation.	0: No action
	CH2	00FD	Selection item:	
	CH3	00FE	0: No action	
	CH4	00FF	By selecting the event output ON/OFF selection from the host, the event output can be output. When the event output ON/OFF selection is set to 0 (event output OFF), the event output is turned off, and when it is set to 1 (event output ON), the event output is turned on. 1: Event output (CH alone) The event output turns ON when any of the selected channel's alarm, heater burnout alarm, or loop error alarm is activated. 2: Event output (CH interlock) The event output turns on when an alarm, heater burnout alarm, or loop error alarm occurs on all channels.	
Event input allocation selection	CH1	0100	Select the event input allocation.	0: No action
	CH2	0101	Selection item:	
	CH3	0102	0: No action	
	CH4	0103	It can be used for any operation by reading the event input status flag. When the event input is turned off, the event input status flag is set to 0, and when the event input is turned on, the event input status flag is set to 1. 1: Control start/stop (CH alone) For the selected channel only, control will start when the event input turns ON, and control will stop when the event input turns OFF. 2: Control start/stop (CH interlock) For all channels, turning on the event input starts the control, and turning off the event input stops the control.	

8.2.10 Detail Setting

Set the detail parameters such as out high limit, out low limit, AT action mode, AT bias and restore action selection when power is turn on.

Click [High function setting] of [Main screen] tab → [Detail setting].

Display the detail setting screen.

The screenshot shows the 'QTC1 console display' application window. The 'Main screen' tab is active, and the 'Detail setting' option is selected in the left-hand menu. The main area displays a table of settings for four channels (CH1, CH2, CH3, CH4). The 'Output high limit setting' is highlighted in blue.

Items	CH1	CH2	CH3	CH4
OUT high limit setting	100.0	100.0	100.0	100.0
OUT low limit setting	0.0	0.0	0.0	0.0
Cooling OUT high limit setting	100.0		100.0	
Cooling OUT low limit setting	0.0		0.0	
AT action mode selection	0: Standard...	0: Standard...	0: Standard...	0: Standard...
AT bias setting	20	20	20	20
AT gain setting	1.0	1.0	1.0	1.0
Alarm 1 value 0 Enabled/Disabled selection	0: Disabled	0: Disabled	0: Disabled	0: Disabled
Alarm 2 value 0 Enabled/Disabled selection	0: Disabled	0: Disabled	0: Disabled	0: Disabled
Alarm 3 value 0 Enabled/Disabled selection	0: Disabled	0: Disabled	0: Disabled	0: Disabled
Alarm 4 value 0 Enabled/Disabled selection	0: Disabled	0: Disabled	0: Disabled	0: Disabled
Proportional band decimal point position selection	0: Second ...	0: Second ...	0: Second ...	0: Second ...
Integral/Derivative decimal point position selection	0: Without ...	0: Without ...	0: Without ...	0: Without ...
Restore action selection when power is turn on	0: Stop	0: Stop	0: Stop	0: Stop
Ch Enabled/Disabled selection	1: Enabled	1: Enabled	1: Enabled	1: Enabled
OUT channel selection	1: CH1	2: CH2	3: CH3	4: CH4
Non-volatile IC memory save selection	0: Save			

Below the table, the 'Output high limit setting' is detailed:

Output high limit setting
 Setting range :
 Output low limit setting value to 100.0 % (105.0 % for DC current output, DC voltage output)
 Default :
 100.0%
 Communication address :
 CH1 : 0030H
 CH2 : 0031H
 CH3 : 0032H
 CH4 : 0033H

(Fig. 8.2.10-1)

Setting item	Channel	Address [HEX]	Description, setting range and selection item	Factory default
OUT high limit setting	CH1	0030	Set the output high limit.	100.0%
	CH2	0031	Setting range:	
	CH3	0032	OUT low limit setting to 100.0%	
	CH4	0033	when current output OUT low limit setting to 105.0%	
OUT low limit setting	CH1	0034	Set the output low limit.	0.0%
	CH2	0035	Setting range:	
	CH3	0036	0.0% to OUT high limit setting	
	CH4	0037	when current output -5.0% to OUT high limit setting	
Cooling output high limit setting	CH1	01AC	Set the cooling output high limit.	100.0%
	CH2	01AD	This is valid when "1: Heating/Cooling	
	CH3	01AE	Control" is selected in control function	
	CH4	01AF	selection. Set to CH1 or CH3. It is disabled when set to CH2 or CH4. Setting range: Cooling OUT low limit setting to 100.0% when current output Cooling OUT low limit setting to 105.0%	
Cooling output low limit setting	CH1	01B0	Set the cooling output low limit.	0.0%
	CH2	01B1	This is valid when "1: Heating/Cooling	
	CH3	01B2	Control" is selected in control function	
	CH4	01B3	selection. Set to CH1 or CH3. It is disabled when set to CH2 or CH4. Setting range: 0.0% to Cooling OUT high limit setting when current output -5.0% to Cooling OUT high limit setting	
AT action mode selection	CH1	00E0	Select the AT action mode.	0: Normal AT
	CH2	00E1	Refer to "12.2.1 Normal AT (P.12-4)" and	
	CH3	00E2	"12.2.2 Start-up AT (P.12-5)".	
	CH4	00E3	Selection item: 0: Normal AT 1: Start-up AT	

Setting item	Channel	Address [HEX]	Description, setting range and selection item	Factory default
AT bias setting	CH1	00E4	Set the bias for normal AT.	20°C (36°F)
	CH2	00E5	The AT point is automatically determined	
	CH3	00E6	based on the deviation between PV and SV.	
	CH4	00E7	The AT bias setting is invalid for direct current input and DC voltage input. Refer to “12.2.1 Normal AT (P.12-4)”. Setting range: 0 to 50°C (0 to 90°F) or 0.0 to 50.0°C (0.0 to 90.0°F)	
AT gain setting	CH1	00E8	Set the ratio of the proportional band	1.0 times
	CH2	00E9	calculated by executing normal AT or Start-up	
	CH3	00EA	AT.	
	CH4	00EB	Setting range: 0.1 to 10.0 times	
Alarm 1 value 0 Enabled/ Disabled selection	CH1	00EC	Select whether to enable or disable the alarm	0: Disabled
	CH2	00ED	action when Alarm 1 setting value is 0.	
	CH3	00EE	Refer to “15.2.7 Alarm Output (P.15-8)”. Selection item:	
	CH4	00EF	0: Disabled 1: Enabled	
Alarm 2 value 0 Enabled/ Disabled selection	CH1	00F0	Select whether to enable or disable the alarm	0: Disabled
	CH2	00F1	action when Alarm 2 setting value is 0.	
	CH3	00F2	Refer to “15.2.7 Alarm Output (P.15-8)”. Selection item:	
	CH4	00F3	0: Disabled 1: Enabled	
Alarm 3 value 0 Enabled/ Disabled selection	CH1	00F4	Select whether to enable or disable the alarm	0: Disabled
	CH2	00F5	action when Alarm 3 setting value is 0.	
	CH3	00F6	Refer to “15.2.7 Alarm Output (P.15-8)”. Selection item:	
	CH4	00F7	0: Disabled 1: Enabled	

Setting item	Channel	Address [HEX]	Description, setting range and selection item	Factory default
Alarm 4 value 0 Enabled/ Disabled selection	CH1	00F8	Select whether to enable or disable the alarm action when Alarm 4 setting value is 0. Refer to "15.2.7 Alarm Output (P.15-8)". Selection item: 0: Disabled 1: Enabled	0: Disabled
	CH2	00F9		
	CH3	00FA		
	CH4	00FB		
Integral/ Derivative decimal point position selection	CH1	0158	Select whether the integration time or the derivative time has no decimal point or has a decimal point. Refer to "15.2.3 Integral/Derivative Decimal Point Position (P.15-6)". Selection item: 0: Without decimal point 1: With decimal point	0: Without decimal point
	CH2	0159		
	CH3	015A		
	CH4	015B		
Power-on restore action selection	CH1	015C	Select whether to resume in the continuous state (state before turning off the power) or in the stopped state when the power is turned on. Selection item: 0: Stopped state (Return to automatic control) 1: Continuous state (Return to automatic control) 2: Stopped state (Return to previous state) 3: Continuous state (Return to previous state)	0: Stopped state
	CH2	015D		
	CH3	015E		
	CH4	015F		
Proportional band decimal point position selection	CH1	0160	Selects the decimal point position for the proportional band. Refer to "15.2.2 Selecting the decimal point position of the proportional band (P.15-6)". Selection item: 0: 2nd decimal place 1: 1st decimal place	0: 2nd decimal place
	CH2	0161		
	CH3	0162		
	CH4	0163		
CH Enabled/ Disabled selection	CH1	0104	Select enable or disable for each channel. If select Disabled, all operations will be disabled for the selected channel. Also, PV becomes 0. Selection item: 0: Disabled 1: Enabled	1: Enabled
	CH2	0105		
	CH3	0106		
	CH4	0107		

Setting item	Channel	Address [HEX]	Description, setting range and selection item	Factory default
Output channel selection	CH1 CH2 CH3 CH4	01C8 01C9 01CA 01CB	Select the input channel for the output of each channel. Refer to "Output selection function (P.15-16)". This is valid when output selection function is selected in control function selection (P.8-30). Selection item: 1: CH1 2: CH2 3: CH3 4: CH4	Input channel same as output channel
Non-volatile IC memory save selection		020B	Select whether to allow or prohibit saving data to the non-volatile IC memory. Refer to "15.2.11 Non-volatile IC Memory Data Save (P.15-9)". Selection item: 0: Save 1: Not save	0: Save

9 Communication Procedure

Communication starts with command transmission from the host computer (hereafter Master), and ends with the response of this instrument (hereafter Slave).

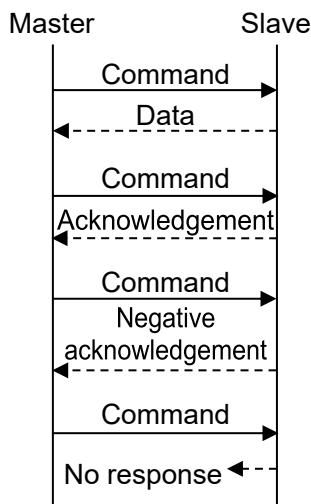

(Fig. 9-1)

- Response with data
When the master sends the Read command, the slave responds with the corresponding set value or current status.
- Acknowledgement
When the master sends the Write command, the slave responds by sending the acknowledgement after the processing is terminated.
- Negative acknowledgement
When the master sends a non-existent command or value out of the setting range, the slave returns a negative acknowledgement.
- No response
The slave will not respond to the master in the following cases:
 - Broadcast address is set.
 - Communication error (framing error, parity error)
 - CRC-16 discrepancy

Communication timing of the RS-485

Master Side (Take note while programming)

When the master starts transmission through the RS-485 communication line, the master is arranged so as to provide an idle status (mark status) transmission period of 1 or more characters before sending the command to ensure synchronization on the receiving side.

Set the program so that the master can disconnect the transmitter from the communication line within a 1 character transmission period after sending the command in preparation for reception of the response from the slave.

To avoid collision of transmissions between the master and the slave, send the next command after carefully checking that the master has received the response.

If a response to the command is not returned due to communication errors, set the Retry Processing to send the command again. (It is recommended to execute Retry twice or more.)

Slave Side

When the slave starts transmission through the RS-485 communication line, the slave is arranged so as to provide an idle status (mark status) transmission period of 1 ms or more (*) before sending the response to ensure synchronization on the receiving side.

The slave is arranged so as to disconnect the transmitter from the communication line within a 1 character transmission period after sending the response.

(*): Can be set in "Communication response delay time setting (P.8-35)" within a range of 0 to 1000 ms.

10 MODBUS Protocol

10.1 Transmission Mode

It becomes the RTU mode, and 8-bit binary data in command is transmitted as it is.

Data format	Start bit:	1 bit
	Data bit:	8 bits
	Parity:	Even (Odd, No parity) (Selectable)
	Stop bit:	1 bit (2 bits) (Selectable)
Error detection:		CRC-16 (Cyclic Redundancy Check)

10.2 Data Communication Interval

1.5 character transmission times or less

(Communication speed 9600 bps, 19200 bps: 1.5 character transmission times,

Communication speed 38400 bps, 57600 bps: 750 μs)

To transmit continuously, an interval between characters which consist of one message, must be within 1.5 character transmission times.

If an interval lasts longer than 1.5 character transmission times, the PCA1 assumes that transmission from the master is finished, which results in a communication error, and will not return a response.

10.3 Message Configuration

Message is configured to start after idle time is processed for more than 3.5 character transmissions, and end after idle time is processed for more than 3.5 character transmissions.

(Communication speed 9600 bps, 19200 bps: 3.5 character transmission times,

Communication speed 38400 bps, 57600 bps: 1.75 ms)

The data part has a maximum of 252 bytes.

3.5 idle characters	Slave address	Function code	Data	Error check CRC-16	3.5 idle characters
---------------------	---------------	---------------	------	--------------------	---------------------

(1) Slave Address

Slave address is an individual instrument number on the slave side, and is set within the range 1 to 16 (01H to 10H). The master identifies slaves by the slave address of the requested message.

The slave informs the master which slave is responding to the master by placing its own address in the response message.

Slave address 0 (00H, Broadcast address) can identify all the slaves connected. However, slaves do not respond.

(2) Function Code

The function code is the command code for the slave to undertake one of the following actions.

Type	Function Code	Sub Function Code	Contents
Data access	03(03H)		Reads a single or multiple piece(s) of data from slave(s) (Amount of data: Max. 100).
	06(06H)		Writes a single piece of data to slave(s).
	16(10H)		Writes multiple pieces of data to slave(s) (Amount of data: Max. 20).

The function code is used to discern whether the response is normal (acknowledgement) or if any error (negative acknowledgement) has occurred when the slave returns the response message to the master.

When acknowledgement is returned, the slave simply returns the original function code.

When negative acknowledgement is returned, the MSB of the original function code is set as 1 for the response.

For example, if the master sends request message setting 13H to the function code by mistake, slave returns 93H by setting the MSB to 1, because the former is an illegal function.

For negative acknowledgement, the exception codes below are set to the data of the response message, and returned to the master in order to inform it of what kind of error has occurred.

Exception Code	Contents
1(01H)	Illegal function (Non-existent function)
2(02H)	Illegal data address (Non-existent data address)
3(03H)	Illegal data value (Value out of the setting range)
17(11H)	Status unable to be written. (AT is performing.)

(3) Data

Data differs depending on the function code.

A request message from the master is composed of a data item, amount of data and setting data.

A response message from the slave is composed of the byte count, data and exception codes in negative acknowledgements, corresponding to the request message.

The effective range of data is -32768 to 32767 (8000H to 7FFFH).

Refer to "11.1 Communication Command List (P.11-1 to P.11-20)".

(4) Error Check

After calculating CRC-16 (Cyclic Redundancy Check) from the slave address to the end of the data, the calculated 16-bit data is appended to the end of message in sequence from low order to high order.

[How to calculate CRC-16]

In the CRC-16 system, the information is divided by the polynomial series. The remainder is added to the end of the information and transmitted. The generation of a polynomial series is as follows.

(Generation of polynomial series: $X^{16} + X^{15} + X^2 + 1$)

- ① Initialize the CRC-16 data (assumed as X) (FFFFH).
- ② Calculate exclusive OR (XOR) with the 1st data and X. This is assumed as X.
- ③ Shift X one bit to the right. This is assumed as X.
- ④ When a carry is generated as a result of the shift, XOR is calculated by X of ③ and the fixed value (A001H). This is assumed as X. If a carry is not generated, go to step ⑤.
- ⑤ Repeat steps ③ and ④ until shifting 8 times.
- ⑥ XOR is calculated with the next data and X. This is assumed as X.
- ⑦ Repeat steps ③ to ⑤.
- ⑧ Repeat steps ③ to ⑤ up to the final data.
- ⑨ Set X as CRC-16 to the end of message in sequence from low order to high order.

10.4 Message Example

Numerals written below the command represent the number of characters.

(1) Read [Slave address 1, CH1 PV (03E8H)]

- A request message from the master

Idle 3.5 characters	Slave address (01H)	Function code (03H)	Data item (03E8H)	Amount of data (0001H)	Error check CRC-16 (047AH)	Idle 3.5 characters
	1	1	2	2	2	

- Response message from the slave in normal status [When PV=600°C (0258H)]

Idle 3.5 characters	Slave address (01H)	Function code (03H)	Response byte count (02H)	Data (0258H)	Error check CRC-16 (B8DEH)	Idle 3.5 characters
	1	1	1	2	2	

(2) Write [Slave address 1, CH1 SV (0018H)]

- A request message from the master [When SV 600°C (0258H)]

Idle 3.5 characters	Slave address (01H)	Function code (06H)	Data item (0018H)	Data (0258H)	Error check CRC-16 (0957H)	Idle 3.5 characters
	1	1	2	2	2	

- Response message from the slave in normal status

Idle 3.5 characters	Slave address (01H)	Function code (06H)	Data item (0018H)	Data (0258H)	Error check CRC-16 (0957H)	Idle 3.5 characters
	1	1	2	2	2	

- Response message from the slave in exception (error) status (When a value out of the setting range is set)

The function code MSB is set to 1 for the response message in exception (error) status, and 86H is returned.

The exception code 03H (Value out of the setting range) is returned (error).

Idle 3.5 characters	Slave address (01H)	Function code (86H)	Exception code (03H)	Error check CRC-16 (0261H)	Idle 3.5 characters
	1	1	1	2	

(3) Read [Slave address 1, CH1 SV(0018H)]

- A request message from the master

Idle 3.5 characters	Slave address (01H)	Function code (03H)	Data item (0018H)	Amount of data (0001H)	Error check CRC-16 (040DH)	Idle 3.5 characters
	1	1	2	2	2	

- Response message from the slave in normal status [When SV 600°C (0258H)]

Idle 3.5 characters	Slave address (01H)	Function code (03H)	Response byte count (02H)	Data (0258H)	Error check CRC-16 (B8DEH)	Idle 3.5 characters
	1	1	1	2	2	

- Response message from the slave in exception (error) status (When data item is incorrect)

The function code MSB is set to 1 for the response message in exception (error) status, and 83H is returned.

The exception code 02H (Non-existent data address) is returned (error).

Idle 3.5 characters	Slave address (01H)	Function code (83H)	Exception code (02H)	Error check CRC-16 (C0F1H)	Idle 3.5 characters
	1	1	1	2	

(4) Write 4 commands [Slave address 1, CH1 SV (0018H) to CH4 SV (001BH)]

(Writing multiple pieces of data)

The configuration of the data is as follows.

Amount of data : 4(0004H)

Byte count : 8(08H)

Data : Data is converted to Hexadecimal.

Data Item		Data	Data (Converted to Hexadecimal)
0018H	CH1 SV setting	600°C	0258H
0019H	CH2 SV setting	600°C	0258H
001AH	CH3 SV setting	600°C	0258H
001BH	CH4 SV setting	600°C	0258H

- A request message from the master (When writing the above data)

Idle 3.5 characters	Slave address (01H)	Function code (10H)	Data item (0018H)	Data (0004080258025802580258H)
	1	1	2	11

Error check CRC-16 (6E98H)	Idle 3.5 characters
2	

- Response message from the slave in normal status

Idle 3.5 characters	Slave address (01H)	Function code (10H)	Data item (0018H)	Data (0004H)	Error check CRC-16 (41CDH)	Idle 3.5 characters
	1	1	2	2	2	

- (5) Read 4 commands [Slave address 1, CH1 SV (0018H) to CH4 SV (001BH)]

(Reading multiple pieces of data)

- A request message from the master (When reading the above data)

Idle 3.5 characters	Slave address (01H)	Function code (03H)	Data item (0018H)	Amount of data (0004H)	Error check CRC-16 (C40EH)	Idle 3.5 characters
	1	1	2	2	2	

- Response message from the slave in normal status

Idle 3.5 characters	Slave address (01H)	Function code (03H)	Response byte count (08H)	Data (0258025802580258H)
	1	1	1	8

Error check CRC-16 (6D15H)	Idle 3.5 characters
2	

The data the response message is as follows.

Data Item		Data	Data (Converted to Hexadecimal)
0018H	CH1 SV setting	600°C	0258H
0019H	CH2 SV setting	600°C	0258H
001AH	CH3 SV setting	600°C	0258H
001BH	CH4 SV setting	600°C	0258H

11 Communication Command List



CAUTION

The communication commands are the same as for QTC1-2.

11.1 Communication Command List

This section explains each item of communication command.

- Data Item
This is a setting item for the control module QTC1-4.
- Amount of data
The amount of data that can be handled by each data item.
The amount of setting items for each channel is 4.
The amount of setting items for each module is 1.
- Channel
This is a channel number of the control module QTC1-4.
- Address [HEX (Hexadecimal), DEC (Decimal)]
This is an each channel address of the control module QTC1-4.
- Attribute
R/W: Read and write (Host ↔ Control module QTC1-4)
RO: Read only (Host ← Control module QTC1-4)
- Data
This is an explanation of the setting range and setting conditions for each data.

Data Item	Amount of data:	Channel	Address		Attribute	Data
			HEX	DEC		
System	4	CH1 CH2 CH3 CH4	0000 0001 0002 0003	0 1 2 3		This is a system item for internal processing. Please do not use.
Control Allowed/ Prohibited selection	4	CH1 CH2 CH3 CH4	0004 0005 0006 0007	4 5 6 7	R/W	0000H: Control Prohibited 0001H: Control Allowed
AT Perform/Cancel selection	4	CH1 CH2 CH3 CH4	0008 0009 000A 000B	8 9 10 11	R/W	0000H: AT cancel 0001H: AT perform
Event output ON/OFF selection	4	CH1 CH2 CH3 CH4	000C 000D 000E 000F	12 13 14 15	R/W	0000H: Event output OFF 0001H: Event output ON
Auto/Manual control selection	4	CH1 CH2 CH3 CH4	0010 0011 0012 0013	16 17 18 19	R/W	0000H: Automatic control 0001H: Manual control
Manual MV setting (*)	4	CH1 CH2 CH3 CH4	0014 0015 0016 0017	20 21 22 23	R/W	-5.0 to 105.0%
SV setting	4	CH1 CH2 CH3 CH4	0018 0019 001A 001B	24 25 26 27	R/W	Scaling low limit to Scaling high limit
Proportional band setting	4	CH1 CH2 CH3 CH4	001C 001D 001E 001F	28 29 30 31	R/W	1 to Input span °C (°F) or 0.1 to Input span °C (°F) For direct current input and DC voltage input: 0.10 to 100.00% or 0.1 to 1000.0%
Integral time setting	4	CH1 CH2 CH3 CH4	0020 0021 0022 0023	32 33 34 35	R/W	0 to 3600 seconds or 0.0 to 2000.0 seconds For "2: Slow-PID control" is selected in control action: 1 to 3600 seconds or 0.1 to 2000.0 seconds
Derivative time setting	4	CH1 CH2 CH3 CH4	0024 0025 0026 0027	36 37 38 39	R/W	0 to 3600 seconds or 0.0 to 2000.0 seconds
Proportional cycle setting	4	CH1 CH2 CH3 CH4	0028 0029 002A 002B	40 41 42 43	R/W	0.1 to 100.0 seconds

(*): This is valid when the manual control is selected in "Auto/Manual control".
When automatic control is selected, negative acknowledgment is returned.

Data Item	Amount of data:	Channel	Address		Attribute	Data
			HEX	DEC		
ON/OFF hysteresis setting	4	CH1	002C	44	R/W	0.1 to 1000.0°C (0.1 to 1800.0°F) For direct current input and DC voltage input: 1 to 10000
		CH2	002D	45		
		CH3	002E	46		
		CH4	002F	47		
Output high limit setting	4	CH1	0030	48	R/W	Output low limit to 100.0% For current output: Output low limit to 105.0%
		CH2	0031	49		
		CH3	0032	50		
		CH4	0033	51		
Output low limit setting	4	CH1	0034	52	R/W	0.0% to output high limit For current output: -5.0% to output high limit
		CH2	0035	53		
		CH3	0036	54		
		CH4	0037	55		
Alarm 1 action selection	4	CH1	0038	56	R/W	0000H: No event 0001H: High limit alarm 0002H: Low limit alarm 0003H: High/Low limits alarm 0004H: High/Low limits range alarm
		CH2	0039	57		
		CH3	003A	58		
		CH4	003B	59		
Alarm 2 action selection	4	CH1	003C	60	R/W	0005H: Process high alarm 0006H: Process low alarm 0007H: High limit with standby 0008H: Low limit with standby 0009H: High/Low limits alarm with standby 000AH: High/Low limits alarm individually 000BH: High/Low limits range alarm individually 000CH: High/Low limits alarm with standby individually
		CH2	003D	61		
		CH3	003E	62		
		CH4	003F	63		
Alarm 3 action selection	4	CH1	0040	64	R/W	0008H: Low limit with standby 0009H: High/Low limits alarm with standby 000AH: High/Low limits alarm individually 000BH: High/Low limits range alarm individually 000CH: High/Low limits alarm with standby individually
		CH2	0041	65		
		CH3	0042	66		
		CH4	0043	67		
Alarm 4 action selection	4	CH1	0044	68	R/W	0.1 to 1000.0°C (0.1 to 1800.0°F) For direct current input and DC voltage input: 1 to 10000
		CH2	0045	69		
		CH3	0046	70		
		CH4	0047	71		
Alarm 1 hysteresis setting	4	CH1	0048	72	R/W	0.1 to 1000.0°C (0.1 to 1800.0°F) For direct current input and DC voltage input: 1 to 10000
		CH2	0049	73		
		CH3	004A	74		
		CH4	004B	75		
Alarm 2 hysteresis setting	4	CH1	004C	76	R/W	0.1 to 1000.0°C (0.1 to 1800.0°F) For direct current input and DC voltage input: 1 to 10000
		CH2	004D	77		
		CH3	004E	78		
		CH4	004F	79		
Alarm 3 hysteresis setting	4	CH1	0050	80	R/W	0.1 to 1000.0°C (0.1 to 1800.0°F) For direct current input and DC voltage input: 1 to 10000
		CH2	0051	81		
		CH3	0052	82		
		CH4	0053	83		
Alarm 4 hysteresis setting	4	CH1	0054	84	R/W	0.1 to 1000.0°C (0.1 to 1800.0°F) For direct current input and DC voltage input: 1 to 10000
		CH2	0055	85		
		CH3	0056	86		
		CH4	0057	87		

Data Item	Amount of data:	Channel	Address		Attribute	Data
			HEX	DEC		
Alarm 1 value setting	4	CH1	0058	88	R/W	Refer to "Alarm 1 to 4 value setting range table (P.11-5)".
		CH2	0059	89		
		CH3	005A	90		
		CH4	005B	91		
Alarm 1 high limit value setting	4	CH1	005C	92	R/W	
		CH2	005D	93		
		CH3	005E	94		
		CH4	005F	95		
Alarm 2 value setting	4	CH1	0060	96	R/W	
		CH2	0061	97		
		CH3	0062	98		
		CH4	0063	99		
Alarm 2 high limit value setting	4	CH1	0064	100	R/W	
		CH2	0065	101		
		CH3	0066	102		
		CH4	0067	103		
Alarm 3 value setting	4	CH1	0068	104	R/W	
		CH2	0069	105		
		CH3	006A	106		
		CH4	006B	107		
Alarm 3 high limit value setting	4	CH1	006C	108	R/W	
		CH2	006D	109		
		CH3	006E	110		
		CH4	006F	111		
Alarm 4 value setting	4	CH1	0070	112	R/W	
		CH2	0071	113		
		CH3	0072	114		
		CH4	0073	115		
Alarm 4 high limit value setting	4	CH1	0074	116	R/W	
		CH2	0075	117		
		CH3	0076	118		
		CH4	0077	119		
Heater burnout alarm setting(*)	4	CH1	0078	120	R/W	For 20 A is selected: 0.0 to 20.0 A For 100 A is selected: 0.0 to 100.0 A
		CH2	0079	121		
		CH3	007A	122		
		CH4	007B	123		
Loop break alarm band setting	4	CH1	007C	124	R/W	0 to 150°C (0 to 270°F) or 0.0 to 150.0°C (0.0 to 270.0°F) For direct current input and DC voltage input: 0 to 1500
		CH2	007D	125		
		CH3	007E	126		
		CH4	007F	127		
Loop break alarm time setting	4	CH1	0080	128	R/W	0 to 200 minutes
		CH2	0081	129		
		CH3	0082	130		
		CH4	0083	131		

(*): CH1 to CH4 correspond to CT input connectors CT1 to CT4, respectively.

When CT is connected to CT3, set to CH3.

Data Item	Amount of data:	Channel	Address		Attribute	Data
			HEX	DEC		
Sensor correction factor setting	4	CH1	0084	132	R/W	0.000 to 10.000
		CH2	0085	133		
		CH3	0086	134		
		CH4	0087	135		
Sensor correction setting	4	CH1	0088	136	R/W	-100.0 to 100.0°C (-180.0 to 180.0°F) For direct current input and DC voltage input: -1000 to 1000
		CH2	0089	137		
		CH3	008A	138		
		CH4	008B	139		
PV filter time constant setting	4	CH1	008C	140	R/W	0.0 to 10.0 seconds
		CH2	008D	141		
		CH3	008E	142		
		CH4	008F	143		
SV rise rate setting	4	CH1	0090	144	R/W	0 to 10000 °C/min (0 to 18000 °F/min) or 0.0 to 1000.0 °C/min (0.0 to 1800.0 °F/min) For direct current input and DC voltage input: 0 to 10000/min
		CH2	0091	145		
		CH3	0092	146		
		CH4	0093	147		
SV fall rate setting	4	CH1	0094	148	R/W	0 to 10000 °C/min (0 to 18000 °F/min) or 0.0 to 1000.0 °C/min (0.0 to 1800.0 °F/min) For direct current input and DC voltage input: 0 to 10000/min
		CH2	0095	149		
		CH3	0096	150		
		CH4	0097	151		
MV bias setting	4	CH1	0098	152	R/W	0.0 to 100.0%
		CH2	0099	153		
		CH3	009A	154		
		CH4	009B	155		

Alarm 1 to 4 value setting range table

Alarm action	Setting range
No event	
High limit alarm	-(Input span) to Input span (*1)
Low limit alarm	-(Input span) to Input span (*1)
High/Low limits alarm	0 to Input span (*1)
High/Low limits range alarm	0 to Input span (*1)
Process high alarm	Input range low limit to Input range high limit (*2)
Process low alarm	Input range low limit to Input range high limit (*2)
High limit with standby	-(Input span) to Input span (*1)
Low limit with standby	-(Input span) to Input span (*1)
High/Low limits alarm with standby	0 to Input span (*1)
High/Low limits alarm individually	0 to Input span (*1)
High/Low limits range alarm individually	0 to Input span (*1)
High/Low limits alarm with standby individually	0 to Input span (*1)

(*1): For DC voltage, direct current input, the input span is the same as the scaling span.

(*2) For DC voltage, direct current input, input range low (or high) limit value is the same as scaling low (or high) limit value.

Data Item	Amount of data:	Channel	Address		Attribute	Data
			HEX	DEC		
Reservation (*)			009C to 00C7			
Input type selection	4	CH1 CH2 CH3 CH4	00C8 00C9 00CA 00CB	200 201 202 203	R/W	<p>For input code M is specified:</p> <p>0000H: K -200 to 1370°C 0001H: K -200.0 to 400.0°C 0002H: J -200 to 1000°C 0003H: R 0 to 1760°C 0004H: S 0 to 1760°C 0005H: B 0 to 1820°C 0006H: E -200 to 800°C 0007H: T -200.0 to 400.0°C 0008H: N -200 to 1300°C 0009H: PL-II 0 to 1390°C 000AH: C(W/Re5-26) 0 to 2315°C 000BH: Pt100 -200.0 to 850.0°C 000CH: 0 to 1 V DC -32768 to 32767 000DH: 4 to 20 mA(Externally mounted shunt resistor) DC -32768 to 32767 000EH: 0 to 20 mA(Externally mounted shunt resistor) DC -32768 to 32767</p> <p>For input code A is specified:</p> <p>0000H: 4 to 20 mA DC(Built-in shunt resistor) -32768 to 32767 0001H: 0 to 20 mA DC(Built-in shunt resistor) -32768 to 32767</p> <p>For input code V is specified:</p> <p>0000H: 0 to 5 V DC -32768 to 32767 0001H: 1 to 5 V DC -32768 to 32767 0002H: 0 to 10 V DC -32768 to 32767</p>
Temperature unit selection	4	CH1 CH2 CH3 CH4	00CC 00CD 00CE 00CF	204 205 206 207	R/W	<p>0000H: °C (Celsius) 0001H: °F (Fahrenheit)</p> <p>For input code M is specified, it can be selected.</p>
Scaling high limit setting	4	CH1 CH2 CH3 CH4	00D0 00D1 00D2 00D3	208 209 210 211	R/W	Scaling low limit value to Rated high limit value
Scaling low limit setting	4	CH1 CH2 CH3 CH4	00D4 00D5 00D6 00D7	212 213 214 215	R/W	Rated low limit value to Scaling high limit value

(*): A single or multiple data are read, the reserved item returns the initial value (0) in acknowledgment. When writing single or multiple, Acknowledgement is returned and the data is discarded.

Data Item	Amount of data:	Channel	Address		Attribute	Data
			HEX	DEC		
Input sampling selection	4	CH1	00D8	216	R/W	0000H: 125 ms 0001H: 50 ms 0002H: 20 ms Fixed to 125 ms for thermocouple input and RTD input. It becomes invalid if a value other than 125 ms is selected.
		CH2	00D9	217		
		CH3	00DA	218		
		CH4	00DB	219		
Direct/Reverse action selection	4	CH1	00DC	220	R/W	0000H: Reverse action 0001H: Direct action
		CH2	00DD	221		
		CH3	00DE	222		
		CH4	00DF	223		
AT action mode selection	4	CH1	00E0	224	R/W	0000H: Normal AT 0001H: Start-up AT
		CH2	00E1	225		
		CH3	00E2	226		
		CH4	00E3	227		
AT bias setting	4	CH1	00E4	228	R/W	0 to 50°C (0 to 90°F) or 0.0 to 50.0°C (0.0 to 90.0°F)
		CH2	00E5	229		
		CH3	00E6	230		
		CH4	00E7	231		
AT gain setting	4	CH1	00E8	232	R/W	0.1 to 10.0 times
		CH2	00E9	233		
		CH3	00EA	234		
		CH4	00EB	235		
Alarm 1 value 0 Enabled/ Disabled selection	4	CH1	00EC	236	R/W	0000H: Disabled 0001H: Enabled
		CH2	00ED	237		
		CH3	00EE	238		
		CH4	00EF	239		
Alarm 2 value 0 Enabled/ Disabled selection	4	CH1	00F0	240	R/W	
		CH2	00F1	241		
		CH3	00F2	242		
		CH4	00F3	243		
Alarm 3 value 0 Enabled/ Disabled selection	4	CH1	00F4	244	R/W	
		CH2	00F5	245		
		CH3	00F6	246		
		CH4	00F7	247		
Alarm 4 value 0 Enabled/ Disabled selection	4	CH1	00F8	248	R/W	
		CH2	00F9	249		
		CH3	00FA	250		
		CH4	00FB	251		

Data Item	Amount of data:	Channel	Address		Attribute	Data
			HEX	DEC		
Event output allocation selection	4	CH1 CH2 CH3 CH4	00FC 00FD 00FE 00FF	252 253 254 255	R/W	<p>0000H: No action By selecting the event output ON/OFF selection from the host, the event output can be output. When the event output ON/OFF selection is set to 0 (event output OFF), the event output is turned off, and when it is set to 1 (event output ON), the event output is turned on.</p> <p>0001H: Event output (CH alone) The event output turns ON when any of the alarm, heater burnout alarm or loop break alarm of the selected channel is activated.</p> <p>0002H: Event output (CH interlocking) The event output turns ON when any of the alarm, heater burnout alarm or loop break alarm is activated in all channels.</p>
Event input allocation selection	4	CH1 CH2 CH3 CH4	0100 0101 0102 0103	256 257 258 259	R/W	<p>0000H: No action It can be used for any operation by reading the event input status flag. 0 is set to the event input status flag when the event input is turned OFF, and 1 is set to it when the event input is turned ON.</p> <p>0001H: Control start/stop (CH alone) For only selected channels, control is started when the event input is turned ON, and control is stop when the event input is turned OFF.</p> <p>0002H: Control start/stop (CH interlocking) For all channels, control is started when the event input is turned ON, and control is stop when the event input is turned OFF.</p>
CH Enabled/ Disabled selection	4	CH1 CH2 CH3 CH4	0104 0105 0106 0107	260 261 262 263	R/W	<p>0000H: Disabled 0001H: Enabled</p>
Number of moving average setting	4	CH1 CH2 CH3 CH4	0108 0109 010A 010B	264 265 266 267	R/W	1 to 10 times

Data Item	Amount of data:	Channel	Address		Attribute	Data
			HEX	DEC		
Reservation (*1)			010C to 012B			
Input math function selection	4	CH1 CH2 CH3 CH4	012C 012D 012E 012F	300 301 302 303	R/W	0000H: Standard 0001H: Difference input (*2) [(CH1-CH2) or (CH3-CH4)] 0002H: Addition input (*2) [(CH1+CH2) or (CH3+CH4)]
Input difference selection	4	CH1 CH2 CH3 CH4	0130 0131 0132 0133	304 305 306 307	R/W	0000H: Disable 0001H: CH1 0002H: CH2 0003H: CH3 0004H: CH4
Input difference setting	4	CH1 CH2 CH3 CH4	0134 0135 0136 0137	308 309 310 311	R/W	1 to 1000°C (1 to 1800°F) or 0.1 to 1000.0°C (0.1 to 1800.0°F) For direct current input and DC voltage input: 1 to 10000
Control action selection(*3)	4	CH1 CH2 CH3 CH4	0138 0139 013A 013B	312 313 314 315	R/W	0000H: 2 DOF PID control 0001H: Fast-PID control 0002H: Slow-PID control 0003H: ON-OFF control 0004H: Gap-PID control Selectable only when control is prohibited.
Proportional gain 2 DOF coefficient (α) setting	4	CH1 CH2 CH3 CH4	013C 013D 013E 013F	316 317 318 319	R/W	0.00 to 1.00 When select “1: Fast-PID control”, “2: Slow-PID control”, “3: ON-OFF control”, or “4: Gap-PID control” in control action, do not change this setting item.
Integral 2 DOF coefficient (β) setting	4	CH1 CH2 CH3 CH4	0140 0141 0142 0143	320 321 322 323	R/W	0.00 to 10.00 When select “1: Fast-PID control”, “2: Slow-PID control”, “3: ON-OFF control”, or “4: Gap-PID control” in control action, do not change this setting item.
Derivative 2 DOF coefficient (γ , Cd) setting	4	CH1 CH2 CH3 CH4	0144 0145 0146 0147	324 325 326 327	R/W	0.00 to 1.00 Do not change this setting item.

(*1): A single or multiple data are read, the reserved item returns the initial value (0) in acknowledgment.

When writing single or multiple, acknowledgement is returned and the data is discarded.

(*2): Select CH1 or CH3 for differential input and addition input.

It is disabled when CH2 or CH4 is selected.

(*3): When integral time is 0 or 0.0, if Slow-PID control is selected or control action is selected when control is enabled (during control execution), error code 17 (11H) is returned with negative acknowledgement.

Data Item	Amount of data:	Channel	Address		Attribute	Data
			HEX	DEC		
Desired value proportional coefficient (Cp) setting	4	CH1	0148	328	R/W	0.00 to 1.00 Do not change this setting item.
		CH2	0149	329		
		CH3	014A	330		
		CH4	014B	331		
Gap width setting	4	CH1	014C	332	R/W	0.0 to 10.0% Proportional band × Gap width
		CH2	014D	333		
		CH3	014E	334		
		CH4	014F	335		
Gap coefficient setting	4	CH1	0150	336	R/W	0.0 to 1.0
		CH2	0151	337		
		CH3	0152	338		
		CH4	0153	339		
Output minimum ON/OFF time setting	4	CH1	0154	340	R/W	0 to 1000 ms
		CH2	0155	341		
		CH3	0156	342		
		CH4	0157	343		
Integral/Derivative decimal point position selection	4	CH1	0158	344	R/W	0000H: Without decimal point 0001H: With decimal point
		CH2	0159	345		
		CH3	015A	346		
		CH4	015B	347		
Power-on restore action selection	4	CH1	015C	348	R/W	0000H: Stopped state (Return to automatic control) 0001H: Continuous state (Return to automatic control) 0002H: Stopped state (Return to previous state) 0003H: Continuous state (Return to previous state)
		CH2	015D	349		
		CH3	015E	350		
		CH4	015F	351		
Proportional band decimal point position selection	4	CH1	0160	352	R/W	0000H: 2nd decimal place 0001H: 1st decimal place
		CH2	0161	353		
		CH3	0162	354		
		CH4	0163	355		
Reservation (*1)			0164 to 018F			
Control function selection	4	CH1	0190	400	R/W	0000H: Standard 0001H: Heating/cooling control (*2) 0002H: Cascade control (*2) 0003H: Output selection function Selectable only when control is prohibited.
		CH2	0191	401		
		CH3	0192	402		
		CH4	0193	403		

(*1): A single or multiple data are read, the reserved item returns the initial value (0) in acknowledgment. When writing single or multiple, Acknowledgement is returned and the data is discarded.

(*2): Select CH1 or CH3 for heating/cooling control and cascade control. It is disabled when CH2 or CH4 is selected.

Data Item	Amount of data:	Channel	Address		Attribute	Data
			HEX	DEC		
Cooling P-band setting (*)	4	CH1	0194	404	R/W	0 to linput span °C (°F) or 0.0 to linput span °C (°F) For direct current input and DC voltage input: 0.00 to 100.00% or 0.0 to 1000.0%
		CH2	0195	405		
		CH3	0196	406		
		CH4	0197	407		
Cooling integral time setting (*)	4	CH1	0198	408	R/W	0 to 3600 seconds or 0.0 to 2000.0 seconds When "2: Slow-PID control" is selected in control action: 1 to 3600 seconds or 0.1 to 2000.0 seconds
		CH2	0199	409		
		CH3	019A	410		
		CH4	019B	411		
Cooling derivative time setting (*)	4	CH1	019C	412	R/W	0 to 3600 seconds or 0.0 to 2000.0 seconds
		CH2	019D	413		
		CH3	019E	414		
		CH4	019F	415		
Cooling proportional cycle setting (*)	4	CH1	01A0	416	R/W	0.1 to 100.0 seconds
		CH2	01A1	417		
		CH3	01A2	418		
		CH4	01A3	419		
Cooling ON/OFF hysteresis setting	4	CH1	01A4	420	R/W	0.1 to 1000.0°C (0.1 to 1800.0°F) For direct current input and DC voltage input: 1 to 10000
		CH2	01A5	421		
		CH3	01A6	422		
		CH4	01A7	423		
Overlap/Dead band setting	4	CH1	01A8	424	R/W	-100.0 to 100.0°C (-180.0 to 180.0°F) For direct current input and DC voltage input: -1000 to 1000
		CH2	01A9	425		
		CH3	01AA	426		
		CH4	01AB	427		
Cooling output high limit setting (*)	4	CH1	01AC	428	R/W	Cooling output low limit to 100.0% For current output: Cooling output low limit to 105.0%
		CH2	01AD	429		
		CH3	01AE	430		
		CH4	01AF	431		
Cooling output low limit setting (*)	4	CH1	01B0	432	R/W	0.0% to Cooling output high limit For current output: -5.0% to Cooling output high limit
		CH2	01B1	433		
		CH3	01B2	434		
		CH4	01B3	435		
Cooling action mode selection (*)	4	CH1	01B4	436	R/W	0000H: Air cooling (Linear characteristics) 0001H: Oil cooling (1.5th power of the linear characteristics) 0002H: Water cooling (2nd power of the linear characteristics)
		CH2	01B5	437		
		CH3	01B6	438		
		CH4	01B7	439		
Slave scale high limit setting (*)	4	CH1	01B8	440	R/W	Slave scale low limit to Slave input range high limit
		CH2	01B9	441		
		CH3	01BA	442		
		CH4	01BB	443		

(*): Set to CH1 or CH3.

It is disabled when set to CH2 or CH4.

Data Item	Amount of data:	Channel	Address		Attribute	Data
			HEX	DEC		
Slave scale low limit setting (*1)	4	CH1 CH2 CH3 CH4	01BC 01BD 01BE 01BF	444 445 446 447	R/W	Slave input range low limit to Slave scale high limit
Output bias setting	4	CH1 CH2 CH3 CH4	01C0 01C1 01C2 01C3	448 449 450 451	R/W	0.0 to 100.0%
Output gain setting	4	CH1 CH2 CH3 CH4	01C4 01C5 01C6 01C7	452 453 454 455	R/W	0.00 to 10.00 times
Output channel selection	4	CH1 CH2 CH3 CH4	01C8 01C9 01CA 01CB	456 457 458 459	R/W	0001H: CH1 0002H: CH2 0003H: CH3 0004H: CH4 This is valid when "Output selection function" is selected in "Control function selection (P.11-10)".
Output rate-of-change setting	4	CH1 CH2 CH3 CH4	01CC 01CD 01CE 01CF	460 461 462 463	R/W	0.00 to 100.00 %/sec
Control action selection when input error		CH1 CH2 CH3 CH4	01D0 01D1 01D2 01D3	464 465 466 467	R/W	0000H: Operation amount set value at input error 0001H: Control operation continued
Output manipulated variable setting when input error		CH1 CH2 CH3 CH4	01D4 01D5 01D6 01D7	468 469 470 471	R/W	0.0 to 100.0 % when direct current and DC voltage input -5.0 to 105.0 %
Reservation (*2)			01D8 to 01F3			
Communication response delay time setting (*3)	1		01F4	500	R/W	0 to 1000 ms
Extension function selection	1		01F5	501	R/W	0000H: Without expanded function 0001H: Peak power suppression function 0002H: Auto balance control function
Total current setting	1		01F6	502	R/W	0.0 to 400.0 A

(*1): Set to CH1 or CH3.

It is disabled when set to CH2 or CH4.

(*2): A single or multiple data are read, the reserved item returns the initial value (0) in acknowledgment.

When writing single or multiple, Acknowledgement is returned and the data is discarded.

(*3): When connecting to the communication expansion module QMC1-C□, set the communication response delay time to 0 ms (initial value).

Data Item	Amount of data:	Channel	Address		Attribute	Data
			HEX	DEC		
Current value setting	4	CH1 CH2 CH3 CH4	01F7 01F8 01F9 01FA	503 504 505 506	R/W	0.0 to 100.0 A
OUT ON delay setting	1		01FB	507		0 to 100 ms
Auto balance control Interlock/Single selection	1		01FC	508	R/W	0000H: Single 0001H: Interlock
Auto balance control Master/Slave selection	1		01FD	509	R/W	0000H: Slave channel 0001H: CH1 master channel 0002H: CH2 master channel 0003H: CH3 master channel 0004H: CH4 master channel
Auto balance control Enabled/Disabled selection	4	CH1 CH2 CH3 CH4	01FE 01FF 0200 0201	510 511 512 513	R/W	0000H: Disabled 0001H: Enabled
Auto balance control start output setting	4	CH1 CH2 CH3 CH4	0202 0203 0204 0205	514 515 516 517	R/W	0.00 to 1.00 (corresponds to 0 to 100%)
Auto balance control cancel area setting(*)	4	CH1 CH2 CH3 CH4	0206 0207 0208 0209	518 519 520 521	R/W	0 to Input span °C (°F) × 10% or 0.0 to Input span °C (°F) × 10% For direct current input and DC voltage input: 0 to Scaling span × 10%
Number of communication management module setting	1		020A	522	R/W	1 to 16 modules
Non-volatile IC memory save selection	1		020B	523	R/W	0000H: Save permission 0001H: Save prohibited
Host setting value change flag clearing selection	1		020C	524	R/W	0000H: Clear 0001H: Do not clear (Change setting value)
USB setting value change flag clearing selection	1		020D	525	R/W	0000H: Clear 0001H: Do not clear (Change setting value)

(*): When set to 0, the auto balance control cancel area is twice the proportional band of the master channel.

Data Item	Amount of data:	Channel	Address		Attribute	Data
			HEX	DEC		
PV reading (including difference)	4	CH1	03E8	1000	RO	Value of "15.2.1 Control Range (P.15-6)" Corresponding to Input calculation function (Difference input, Addition input) and Input difference detection. (*2)
		CH2	03E9	1001		
		CH3	03EA	1002		
		CH4	03EB	1003		
MV reading	4	CH1	03EC	1004	RO	Output low limit to Output high limit
		CH2	03ED	1005		
		CH3	03EE	1006		
		CH4	03EF	1007		
SV reading	4	CH1	03F0	1008	RO	Scaling low limit to Scaling high limit
		CH2	03F1	1009		
		CH3	03F2	1010		
		CH4	03F3	1011		
Status flag 1 reading	4	CH1	03F4	1012	RO	B0: Control Enable/Diseble 0: Diseble 1: Enable B1: AT Perform/Cancel 0: Cancel 1: Perform B2: Auto/Manual control 0: Automatic 1: Manual B3: Control output 0: OFF 1: ON B4: Input error (Overscale) 0: Normal 1: Error B5: Input Error (Underscale) 0: Normal 1: Error B6: Alarm 1 output 0: OFF 1: ON B7: Alarm 2 output 0: OFF 1: ON B8: Alarm 3 output 0: OFF 1: ON B9: Alarm 4 output 0: OFF 1: ON B10: Loop break alarm output 0: OFF 1: ON B11: Heater burnout alarm output 0: OFF 1: ON B12: Input difference 0: Within range 1: Without range B13: Not used (indefinite) B14: Power supply identification (*) 0: 24 V DC 1: USB bus power B15: Non-volatile IC memory error 0: Normal 1: Error
		CH2	03F5	1013		
		CH3	03F6	1014		
		CH4	03F7	1015		

(*1): When power is supplied from the host computer by USB bus power, 0 is returned.

(*2): When power is supplied from 24 V DC and USB bus power, 0: 24 V DC is returned.

Data Item	Amount of data:	Channel	Address		Attribute	Data
			HEX	DEC		
Status flag 2 reading	4	CH1 CH2 CH3 CH4	03F8 03F9 03FA 03FB	1016 1017 1018 1019	RO	B0: Auto balance control 0: None 1: During auto balance control B1 to B3: Not used (indefinite) B4: Cold junction error 0: Normal 1: Error B5: Sensor error 0: Normal 1: Error B6: ADC error 0: Normal 1: Error B7: Host setting value change flag (*1) 0: Without flag 1: With flag B8: USB setting value change flag (*2) 0: Without flag 1: With flag B9 to B15: Not used (indefinite)
Heater current value reading	4	CH1 CH2 CH3 CH4	03FC 03FD 03FE 03FF	1020 1021 1022 1023	RO	0.0 to 20.0 A or 0.0 to 100.0 A
Event input reading	4	CH1 CH2 CH3 CH4	0400 0401 0402 0403	1024 1025 1026 1027	RO	0000H: OFF 0001H: ON
Event output reading	4	CH1 CH2 CH3 CH4	0404 0405 0406 0407	1028 1029 1030 1031	RO	0000H: OFF 0001H: ON

(*1): The host setting value change flag sets "1: With flag" in B7: Host setting value change flag when there is a change in the setting value from the host communication side.

When Clear (0000H) is received in the host setting value change flag clearing selection (020CH), B7: Host setting value change flag is set to "0: Without flag".

(*2): The USB setting value change flag sets "1: With flag" in B8: USB setting value change flag when there is a change in the setting value from the USB communication side.

When Clear (0000H) is received in the USB setting value change flag clearing selection (020DH), B8: USB setting value change flag is set to "0: Without flag".

Data Item	Amount of data:	Channel	Address		Attribute	Data
			HEX	DEC		
PV reading (true value)	4	CH1	0408	1032	RO	Value of "15.2.1 Control Range (P.15-6)" The input value of each channel is read regardless of the calculation function (Difference input, Addition input) and input difference detection. (*1)
		CH2	0409	1033		
		CH3	040A	1034		
		CH4	040B	1035		
Ambient temperature reading	4	CH1	040C	1036	RO	Read the input terminal temperature of each channel. (*2)
		CH2	040D	1037		
		CH3	040E	1038		
		CH4	040F	1039		

(*1): When power is supplied from the host computer by USB bus power, 0 is returned.

(*2): When thermocouple input, convert it to a value according to temperature unit selection.

For the read value, the value of the first decimal place is returned regardless of the presence or absence of a decimal point in the input range.

(Example) If 0.0 °C (32.0 °F), the read value will be 0 (320).

When RTD input, direct current input, and DC voltage input, 0 is returned.

Data Item	Amount of data:	Channel	Address		Attribute	Data
			HEX	DEC		
Alarm history 1 Error No.	4	CH1	044C	1100	RO	B0: Alarm 1 0: Normal 1: Error B1: Alarm 2 0: Normal 1: Error B2: Alarm 3 0: Normal 1: Error B3: Alarm 4 0: Normal 1: Error B4: Heater burnout alarm 0: Normal 1: Error B5: Not used (indefinite) B6: Loop break alarm 0: Normal 1: Error B7: Sensor error 0: Normal 1: Error B8: Input error (Overscale) 0: Normal 1: Error B9: Input error (Underscale) 0: Normal 1: Error B10: Cold junction error 0: Normal 1: Error B11: Non-volatile IC memory error 0: Normal 1: Error B12: ADC error 0: Normal 1: Error B13: Not used (indefinite) B14: Not used (indefinite) B15: Not used (indefinite)
		CH2	044D	1101		
		CH3	044E	1102		
		CH4	044F	1103		
Alarm history 2 Error No.	4	CH1	0450	1104	RO	
		CH2	0451	1105		
		CH3	0452	1106		
		CH4	0453	1107		
Alarm history 3 Error No.	4	CH1	0454	1108	RO	
		CH2	0455	1109		
		CH3	0456	1110		
		CH4	0457	1111		
Alarm history 4 Error No.	4	CH1	0458	1112	RO	
		CH2	0459	1113		
		CH3	045A	1114		
		CH4	045B	1115		
Alarm history 5 Error No.	4	CH1	045C	1116	RO	
		CH2	045D	1117		
		CH3	045E	1118		
		CH4	045F	1119		
Alarm history 6 Error No.	4	CH1	0460	1120	RO	
		CH2	0461	1121		
		CH3	0462	1122		
		CH4	0463	1123		
Alarm history 7 Error No.	4	CH1	0464	1124	RO	
		CH2	0465	1125		
		CH3	0466	1126		
		CH4	0467	1127		
Alarm history 8 Error No.	4	CH1	0468	1128	RO	
		CH2	0469	1129		
		CH3	046A	1130		
		CH4	046B	1131		
Alarm history 9 Error No.	4	CH1	046C	1132	RO	
		CH2	046D	1133		
		CH3	046E	1134		
		CH4	046F	1135		
Alarm history 10 Error No.	4	CH1	0470	1136	RO	
		CH2	0471	1137		
		CH3	0472	1138		
		CH4	0473	1139		

Data Item	Amount of data:	Channel	Address		Attribute	Data
			HEX	DEC		
Alarm history 1 Total energizing time	4	CH1	0474	1140	RO	Total energizing time when an error occurs
		CH2	0475	1141		
		CH3	0476	1142		
		CH4	0477	1143		
Alarm history 2 Total energizing time	4	CH1	0478	1144	RO	
		CH2	0479	1145		
		CH3	047A	1146		
		CH4	047B	1147		
Alarm history 3 Total energizing time	4	CH1	047C	1148	RO	
		CH2	047D	1149		
		CH3	047E	1150		
		CH4	047F	1151		
Alarm history 4 Total energizing time	4	CH1	0480	1152	RO	
		CH2	0481	1153		
		CH3	0482	1154		
		CH4	0483	1155		
Alarm history 5 Total energizing time	4	CH1	0484	1156	RO	
		CH2	0485	1157		
		CH3	0486	1158		
		CH4	0487	1159		
Alarm history 6 Total energizing time	4	CH1	0488	1160	RO	
		CH2	0489	1161		
		CH3	048A	1162		
		CH4	048B	1163		
Alarm history 7 Total energizing time	4	CH1	048C	1164	RO	
		CH2	048D	1165		
		CH3	048E	1166		
		CH4	048F	1167		
Alarm history 8 Total energizing time	4	CH1	0490	1168	RO	
		CH2	0491	1169		
		CH3	0492	1170		
		CH4	0493	1171		
Alarm history 9 Total energizing time	4	CH1	0494	1172	RO	
		CH2	0495	1173		
		CH3	0496	1174		
		CH4	0497	1175		
Alarm history 10 Total energizing time	4	CH1	0498	1176	RO	
		CH2	0499	1177		
		CH3	049A	1178		
		CH4	049B	1179		

Data Item	Amount of data:	Channel	Address		Attribute	Data
			HEX	DEC		
Contact switching total number of times (High)	4	CH1 CH2 CH3 CH4	049C 049D 049E 049F	1180 1181 1182 1183	RO	Contact switching total number of times (High)
Contact switching total number of times (Low)	4	CH1 CH2 CH3 CH4	04A0 04A1 04A2 04A3	1184 1185 1186 1187	RO	Contact switching total number of times (Low)
Total energizing time (High, Low)	4	(High) (Low)	04A4 04A5 04A6 04A7	1188 1189 1190 1191	RO	Total energizing time 1 count/10 min 1190, 1191 is always 0.
Heater accumulated energizing time (High)	4	CH1 CH2 CH3 CH4	04A8 04A9 04AA 04AB	1192 1193 1194 1195	RO	Heater accumulated energizing time (High) 1 count/1 min
Heater accumulated energizing time (Low)	4	CH1 CH2 CH3 CH4	04AC 04AD 04AE 04AF	1196 1197 1198 1199	RO	Heater accumulated energizing time (Low) 1 count/1 min
Output form	4	CH1 CH2 CH3 CH4	04B0 04B1 04B2 04B3	1200 1201 1202 1203	RO	0000H: Relay contact output 0001H: Non-contact voltage (for SSR drive) output 0002H: Open collector output 0003H: Not used (indefinite) 0004H: DC current output 4 to 20 mA DC 0005H: DC current output 0 to 20 mA DC 0006H: DC voltage output 0 to 1 V DC 0007H: DC voltage output 0 to 5 V DC 0008H: DC voltage output 1 to 5 V DC 0009H: DC voltage output 0 to 10 V DC
Input form	4	CH1 CH2 CH3 CH4	04B4 04B5 04B6 04B7	1204 1205 1206 1207	RO	0000H: Input code M 0001H: Input code A 0002H: Input code V
Product code	1		04B8	1208	RO	Product code
Presence of communication option	1		04B9	1209	RO	0000H: No option 0001H: With power supply/host communication function 0002H: With power supply/CUnet communication function
Wiring type	1		04BA	1210	RO	0000H: Terminal type 0001H: Connector type
Presence of heater burnout alarm option	1		04BB	1211	RO	0000H: No option 0001H: Rated 20 A 0002H: Rated 100 A

Data Item	Amount of data:	Channel	Address		Attribute	Data
			HEX	DEC		
Presence of event option	1		04BC	1212	RO	0000H: No option 0001H: Event input (4 points) 0002H: Event output (4 points)
Software version	1		04BD	1213	RO	Software version
Manufacturing date	1		04BE	1214	RO	Manufacturing date (e.g. 2009: September 2020)
Hardware version	1		04BF	1215	RO	Hardware version
Reservation (*)			04C0 to 0513			
Maintenance mode selection	1		0514	1300	R/W	0000H: Normal mode 0001H: Maintenance mode
Control output forced ON/OFF selection	4	CH1 CH2 CH3 CH4	0515 0516 0517 0518	1301 1302 1303 1304	R/W	0000H: Control output OFF 0001H: Control output ON
Event output forced ON/OFF selection	4	CH1 CH2 CH3 CH4	0519 051A 051B 051C	1305 1306 1307 1308	R/W	0000H: Event output OFF 0001H: Event output ON
Contact switching total number of times setting (High)	4	CH1 CH2 CH3 CH4	051D 051E 051F 0520	1309 1310 1311 1312	R/W	Contact switching total number of times (High)
Contact switching total number of times setting (Low)	4	CH1 CH2 CH3 CH4	0521 0522 0523 0524	1313 1314 1315 1316	R/W	Contact switching total number of times (Low)
Heater accumulated energizing time setting (High)	4	CH1 CH2 CH3 CH4	0525 0526 0527 0528	1317 1318 1319 1320	R/W	Heater accumulated energizing time (High) 1 count/1 min
Heater accumulated energizing time setting (Low)	4	CH1 CH2 CH3 CH4	0529 052A 052B 052C	1321 1322 1323 1324	R/W	Heater accumulated energizing time (Low) 1 count/1 min

(*): A single or multiple data are read, the reserved item returns the initial value (0) in acknowledgment.
When writing single or multiple, Acknowledgement is returned and the data is discarded.

11.2 Data

11.2.1 Notes About Write/Read Command

- The data (set value, decimal) is converted to a hexadecimal number. Negative numbers are represented in 2's complement.
- Do not use undefined Data items. If they are used, negative acknowledgement will be returned or a random value will be written or read, resulting in malfunction.
- MODBUS protocol uses Holding Register addresses. The Holding Register addresses are created as follows.

A data item is converted to decimal number, and the offset of 40001 is added. The result is the Holding Register address.

Using CH1 SV (0018H) as an example: Data item in the sending message is 0018H, however, MODBUS protocol Holding Register address is 40025 (24+40001).

11.2.2 Write Command

- The lifetime of the non-volatile IC memory is about 1 trillion times writes. Do not change the set value frequently by communication, as the set value storage retention time may be shortened if the number of times is exceeded. (If the set value is the same as the value before setting, it is not written to the non-volatile IC memory.)
- When data (set value) has a decimal point, a whole number (hexadecimal) without a decimal point is used.
- If the operation is changed with Alarm 1 action to Alarm 4 action (0038H to 0047H), Alarm 1 value to Alarm 4 value (0058H to 0077H) will return to the factory default values. For the items to be initialized, refer to "11.5 Initialization Items by Changing Settings (P.11-23)".
- Even if options are not ordered, writing via software communication will be possible. However, their command contents will not function.
- Communication parameters such as module address and communication speed of this instrument cannot be written by software communication. Set it with the rotary switch for module address selection and the dip switch for selecting communication specifications.
- When Write is executed using the Broadcast address [(00H) MODBUS protocol] command, the command is sent to all the connected slaves. However, a response is not returned.

11.2.3 Read Command

- When the data (set value) has a decimal point, a whole number (hexadecimal) without a decimal point is used for a response.

11.3 Negative Acknowledgement

11.3.1 Error Code 2 (02H)

The slave will return Error code 2 (02H) in the following case.

- When non-existent data item is read or written.

11.3.2 Error Code 3 (03H)

The slave will return Error code 3 (03H) in the following case.

- When a value out of the setting range is written.

11.3.3 Error Code 17 (11H)

The slave will return Error code 17 (11H) in the following case.

- When AT execution (0001H) is written with AT execution/stop selection (0008H to 000BH) during PI operation or ON/OFF operation.
- When AT execution (0001H) is written with AT execution/stop selection (0008H to 000BH) during AT execution.
When the control enable/disable selection (0004H to 0007H) is written during AT execution.
- When manual control MV setting (0014H to 0017H) is written during automatic control.

11.4 Notes on Programming Monitoring Software

11.4.1 How to Speed up the Scan Time

When monitoring multiple this instrument, set the program so that the requisite minimum pieces of data such as PV (03E8H to 03EBH), MV (03ECH to 03EFH), Status flag 1 (03F4H to 03F7H) can be read.

For other data, set the program so that they can be read only when their set value has changed.

This will speed up the scan time.

11.4.2 How to Read PID Parameters after AT or Start-up AT Finishes

While AT or Start-up AT is performing, this instrument sets "B1: AT Perform/Cancel" of "Status flag 1 (03F4H to 03F7H)" to "1: AT Perform".

After AT or Start-up AT is finished, PID parameters are updated.

On the monitoring software side, check that "B1: AT Perform/Cancel" of "Status flag 1 (03F4H to 03F7H)" has been set to "0: AT Cancel", then read parameters such as P, I, D.

11.4.3 Notes on Batch Transmission of All Setting Values

- If the operation is changed with Alarm 1 action to Alarm 4 action (0038H to 0047H), Alarm 1 value to Alarm 4 value (0058H to 0077H) will return to the factory default values.
Send the Alarm action and then the Alarm value.
For the items to be initialized, refer to "11.5 Items to be Initialized by Changing Settings (P.11-23)".
- If the input type is changed with Input type (00C8H to 00CBH), the setting values such as SV, Proportional band, and Alarm 1 value are initialized.
Send the Input type and then the other setting values.
For the items to be initialized, refer to "11.5 Initialization Items by Changing Settings (P.11-23)".

11.5 Initialization Items by Changing Settings

The items that are initialized by changing the settings are shown below.

○: Initialize

—: Not initialize

Setting change item Initialized item	Input type (00C8H to 00CBH)	Temperature unit (00CCH to 00CFH)	Alarm 1 action (0038H to 003BH)	Alarm 2 action (003CH to 003FH)	Alarm 3 action (0040H to 0043H)	Alarm 4 action (0044H to 0047H)
SV (0018H to 001BH)	○	○	—	—	—	—
Proportional band (001CH to 001FH)	○	○	—	—	—	—
ON/OFF hysteresis (002CH to 002FH)	○	○	—	—	—	—
Alarm 1 hysteresis (0048H to 004BH)	○	○	○	—	—	—
Alarm 2 hysteresis (004CH to 004FH)	○	○	—	○	—	—
Alarm 3 hysteresis (0050H to 0053H)	○	○	—	—	○	—
Alarm 4 hysteresis (0054H to 0057H)	○	○	—	—	—	○
Alarm 1 value (0058H to 005BH)	○	○	○	—	—	—
Alarm 1 high limit value (005CH to 005FH)	○	○	○	—	—	—
Alarm 2 value (0060H to 0063H)	○	○	—	○	—	—
Alarm 2 high limit value (0064H to 0067H)	○	○	—	○	—	—
Alarm 3 value (0068H to 006BH)	○	○	—	—	○	—
Alarm 3 high limit value (006CH to 006FH)	○	○	—	—	○	—
Alarm 4 value (0070H to 0073H)	○	○	—	—	—	○
Alarm 4 high limit value (0074H to 0077H)	○	○	—	—	—	○
Loop break alarm band (007CH to 007FH)	○	○	—	—	—	—
Loop break alarm time (0080H to 0083H)	○	○	—	—	—	—
Sensor correction factor (0084H to 0087H)	○	○	—	—	—	—
Sensor correction (0088H to 008BH)	○	○	—	—	—	—
SV rise rate (0090H to 0093H)	○	○	—	—	—	—
SV fall rate (0094H to 0097H)	○	○	—	—	—	—
Scaling high limit (00D0H to 00D3H)	○	○	—	—	—	—
Scaling low limit (00D4H to 00D7H)	○	○	—	—	—	—
AT bias (00E4H to 00E7H)	○	○	—	—	—	—
Input difference (0134H to 0137H)	○	○	—	—	—	—
Cooling P-band(0194H to 0197H)	○	○	—	—	—	—
Slave scale high limit (01B8H to 01BBH)	○	○	—	—	—	—
Slave scale low limit (01BCH to 01BFH)	○	○	—	—	—	—
Auto balance control cancel area (0206H to 0209H)	○	○	—	—	—	—

12 Operation

This section describes the operation when operating by communicating with the host computer. Refer to “11.1 Communication Command List (P.11-1 to P.11-20)” for setting the control parameters such as SV and alarm required for operation.

12.1 Control Permission

(1) Before turning the power ON

Check the following contents before turning the power ON to this instrument.

- Preparation of communication program
A communication program is required to connect and use the host computer.
Refer to “10 MODBUS Protocol (P.10-1 to P.10-5)” to create the communication program.
- Select communication specifications
Select the communication specifications such as communication speed, data bit, and parity.
Refer to “5.1.1 Selection of Communication Specifications (P.5-1, P.5-2)”.
- Select module address
Select the module address.
Refer to “5.1.2 Selection of Module Address (P.5-3)”.
- Mounting
Mount the control module QTC1-4 to the DIN rail.
Refer to “6 Mounting (P.6-1 to P.6-7)”.
- Wiring
Wire the control module QTC1-4.
Refer to “7 Wiring (P.7-1 to P.7-7)”.
- Connection of host computer and control module QTC1 4
Connect the host computer and control module QTC1-4.
Refer to “7.5 Connection of Host Computer and Control Module QTC1 4 (P.7-8, P.7-9)”.

(2) After turning the power ON

Check the following contents after turning the power ON to this instrument.

- Specification setting
Set specifications such as input parameters and output parameters.
Refer to “8 Setting of Specification (P.8-1 to P.8-41)”.
- Control parameters setting
Set the control parameters such as SV and alarm.
Refer to “11.1 Communication Command List (P.11-1 to P.11-20)”.

(3) Turn OFF → ON the QTC1-4 power

Turn OFF → ON the power of QTC1-4. The set value becomes effective.

(4) Turn ON the load circuit power

(5) Permission of control

Select "Control Allowed" in "Control Allowed/Prohibited".

The control operation starts so that the controlled object keeps CH1 SV.

Control Allowed [Slave address 1, Control Allowed/Prohibited of CH1]

- A request message from the master

Idle 3.5 characters	Slave address (01H)	Function code (06H)	Data item (0004H)	Data (0001H)	Error check CRC-16 (09CBH)	Idle 3.5 characters
	1	1	2	2	2	

- Response message from the slave in normal status

Idle 3.5 characters	Slave address (01H)	Function code (06H)	Data item (0004H)	Data (0001H)	Error check CRC-16 (09CBH)	Idle 3.5 characters
	1	1	2	2	2	

12.2 Set PID Constants (Execute AT)



Caution

- Perform the AT during the trial run.
- During AT, the all setting items can not be set.
- If a power failure occurs during AT execution, AT will be stopped.
- If AT is cancelled during the process, each setting values of P, I, D will revert to the values before AT was performed.
- If AT does not end about 4 hours after starting AT, AT is automatically stopped.
- If AT is executed near normal temperature, the temperature may not change and AT may not end normally.
- When AT is executed under Gap-PID control, D is calculated in 0 seconds.

Execute AT to set the PID constant.

There are two types of AT for this instrument, Normal AT and Start-up AT.

Refer to “AT action mode selection (00E0H to 00E3H) (P.11-7)” for AT action selection.

Start-up AT [Slave address 1, AT action of CH1]

- A request message from the master

Idle 3.5 characters	Slave address (01H)	Function code (06H)	Data item (00E0H)	Data (0001H)	Error check CRC-16 (49FCH)	Idle 3.5 characters
	1	1	2	2	2	

- Response message from the slave in normal status

Idle 3.5 characters	Slave address (01H)	Function code (06H)	Data item (00E0H)	Data (0001H)	Error check CRC-16 (49FCH)	Idle 3.5 characters
	1	1	2	2	2	

12.2.1 Normal AT

In order to set each value of P, I, D and ARW automatically, the AT process should be made to fluctuate to obtain an optimal value.

For DC voltage, direct current inputs, the AT process will fluctuate around the SV for conditions of [A], [B] and [C] below. One of 3 types of fluctuation below is automatically selected depending on the deviation between SV and PV.

When AT is executed under Gap-PID control, D is calculated in 0 seconds.

[A] If there is a large difference between the SV and PV as the temperature is rising

When AT bias is set to 20°C (°F), AT process will fluctuate at the temperature 20°C (°F) lower than the SV.

(Abbreviation: Temp.: Temperature)

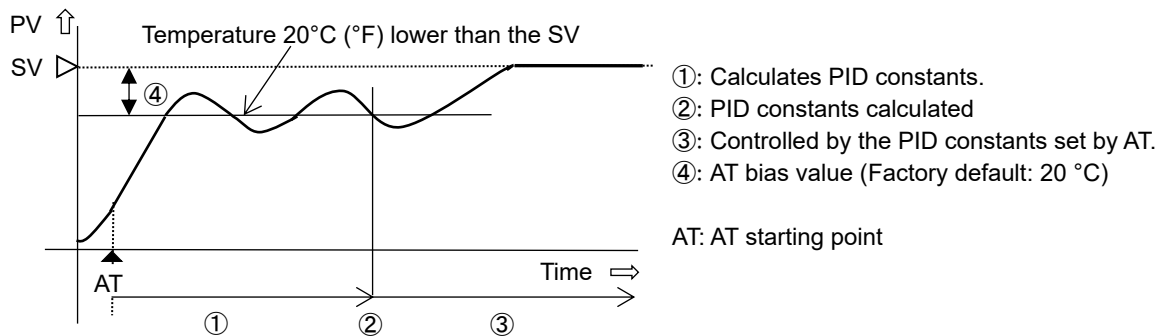

(Fig. 12.2.1-1)

[B] When the control is stable

The AT process will fluctuate around the SV.

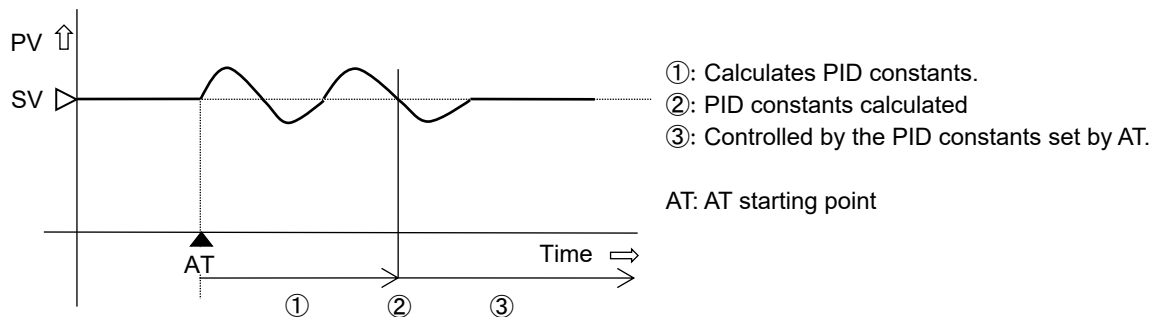

(Fig. 12.2.1-2)

[C] If there is a large difference between the SV and PV as the temperature is falling

When AT bias is set to 20°C (°F), AT process will fluctuate at the temperature 20°C (°F) higher than the SV.

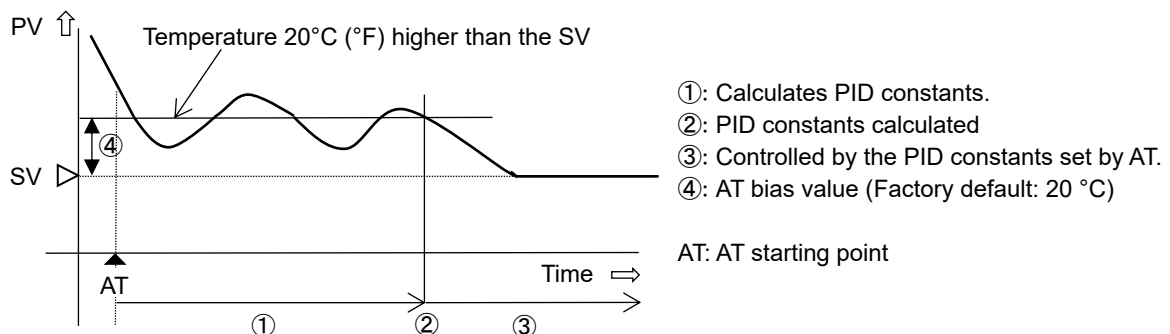

(Fig. 12.2.1-3)

12.2.2 Start-up AT

Start-up AT calculates each set value of P, I, D only in the temperature rising state when normal AT is not performed due to temperature interference.

The Start-up AT is not executed for "Heating/Cooling Control" or "Direct action". Select "Normal AT" in "AT Action" and execute.

The start-up AT execution selection value is stored inside this instrument. Therefore, if "Control enable/disable" is selected for "Control enable", Start-up AT is executed every time.

If you want to stop the Start-up AT, select "Normal AT" in "AT Action".

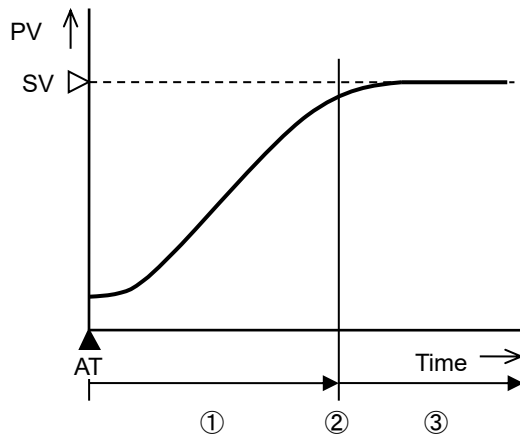

- ①: AT measurement in progress
- ②: PID constants calculated
- ③: Controlled by PID constant set by startup AT

(Fig. 12.2.2-1)

[Start-up AT execution conditions]

- At the start of Start-up AT, if the deviation between SV and PV is more than twice the proportional band, select Start-up AT with "AT Action" and select "AT Perform (Start-up with AT Perform/Cancel)". If you select "Run AT", Start-up AT is executed. However, if the PV slope and delay time cannot be measured normally to calculate P, I, and D, Start-up AT is stopped. Even after Start-up AT is completed normally, "AT Perform/Cancel" remains "AT Perform". Under the above execution conditions, if "Control enable" is selected in "Control enable/disable", Start-up AT is executed again. If you want to stop Start-up AT, select "Normal AT" in "AT Action".

[Start-up AT stop conditions]

- When "Control disable" is selected in "Control enable/disable"
- When the derivative time is set to 0
- When the input burned out

12.2.3 AT Gain Setting

Normally, set the ratio of the proportional band calculated by AT and Start-up AT.

Please set if necessary.

Setting range: 0.1 to 10.0 times (factory default: 1.0 times)

12.2.4 Executing AT

Refer to "AT Perform/Cancel selection (0008H to 000BH) (P.11-2)" and select "AT Perform".

AT Perform [Slave address 1, AT Perform/Cancel of CH1]

- A request message from the master

Idle 3.5 characters	Slave address (01H)	Function code (06H)	Data item (0008H)	Data (0001H)	Error check CRC-16 (C9C8H)	Idle 3.5 characters
	1	1	2	2	2	

- Response message from the slave in normal status

Idle 3.5 characters	Slave address (01H)	Function code (06H)	Data item (0008H)	Data (0001H)	Error check CRC-16 (C9C8H)	Idle 3.5 characters
	1	1	2	2	2	

During AT execution, set "AT Perform (1)" in B1: AT Perform/Cancel of Status flag 1 (1012H to 1015H).

When AT ends, B1: AT Perform/Cancel of Status flag 1 (1012H to 1015H) is set to "AT Cancel (0)", and control is performed with the PID constant set in AT.

In addition, the data written by "AT Perform/Cancel (0008H to 000BH)" is automatically cleared [AT Cancel (0000H)].

If AT does not end about 4 hours after starting AT, AT is automatically stopped.

12.3 Set Alarm

For Alarm output, the alarm value is set by deviation from the SV (excluding Process alarm), and if the PV goes outside the range, the Alarm output is turned ON (turned OFF for High/Low limit range alarm). It can select from High limit alarm, Low limit alarm, High/Low limits alarm, High/Low limit range alarm, Process high alarm, Process low alarm, High limit with standby alarm, Low limit with standby alarm, High/Low limits with standby alarm, High/Low limits alarm individually, High/Low limit range alarm individually, High/Low limits with standby alarm individually or no operation. Refer to “14.5.3 Alarm Action (P.14-33, P.14-34)” for detail of alarm action.

Alarm settings are made using Alarm action and Alarm value.

If the operation is changed with Alarm 1 action to Alarm 4 action (0038H to 0047H), Alarm 1 value to Alarm 4 value (0058H to 0077H) will return to the factory default values.

Send the Alarm action and then the Alarm value.

This section describes the CH1 alarm 1 setting example and alarm operation.

[Setting example]

Setting item	Setting value
SV	600°C
Alarm 1 action	Hogh limit alarm
Alarm 1 value	20°C
Alarm 1 hysteresis	1.0°C

[Alarm action]

When PV will be more than 620°C, Alarm 1 output turns ON.

When PV will be less than 619°C, Alarm 1 output turns OFF.

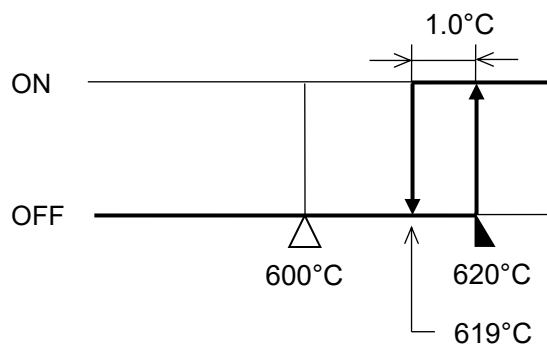

(Fig. 12.3-1)

High limit alarm [Slave address 1, Alarm 1 action of CH1]

- A request message from the master

Idle 3.5 characters	Slave address (01H)	Function code (06H)	Data item (0038H)	Data (0001H)	Error check CRC-16 (C9C7H)	Idle 3.5 characters
	1	1	2	2	2	

- Response message from the slave in normal status

Idle 3.5 characters	Slave address (01H)	Function code (06H)	Data item (0038H)	Data (0001H)	Error check CRC-16 (C9C7H)	Idle 3.5 characters
	1	1	2	2	2	

20°C (0014H) [Slave address 1, Alarm 1 value of CH1]

- A request message from the master

Idle 3.5 characters	Slave address (01H)	Function code (06H)	Data item (0058H)	Data (0014H)	Error check CRC-16 (0816H)	Idle 3.5 characters
	1	1	2	2	2	

- Response message from the slave in normal status

Idle 3.5 characters	Slave address (01H)	Function code (06H)	Data item (0058H)	Data (0014H)	Error check CRC-16 (0816H)	Idle 3.5 characters
	1	1	2	2	2	

12.4 Correct Process Variable

When a sensor cannot be set at the exact location where control is desired, the sensor-measured temperature may deviate from the temperature in the controlled location. When using multiple indicating controllers, sometimes the measured temperatures do not concur due to differences in sensor accuracy or dispersion of load capacities. In such a case, the control can be set at the desired temperature by adjusting the input value of sensors. However, it is effective within the input rated range regardless of the sensor correction value.

The input value is corrected by the sensor correction factor and the sensor correction.

The sensor correction factor sets the slope, and the sensor correction sets the difference between before and after correction.

PV after input correction is expressed by the following formula.

PV after input correction =

$$\text{Current PV} \times \text{Sensor correction factor setting value} + (\text{Sensor correction setting value})$$

An example of input value correction using a combination of Sensor correction factor and Sensor correction is shown below.

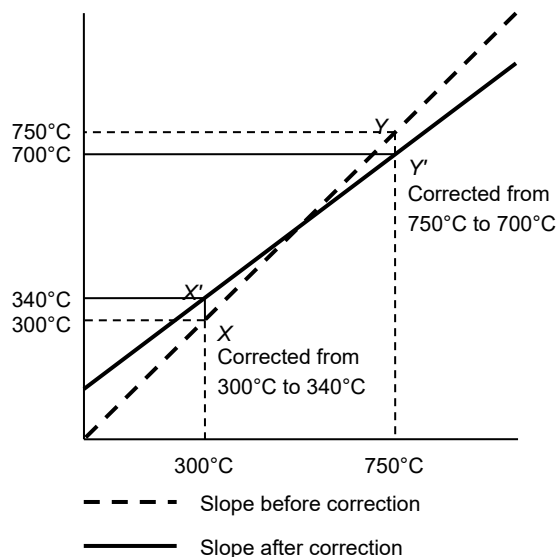

(Fig. 12.4-1)

- (1) Extract two points to be corrected and determine the PV after correction.
Before correction: 300°C → After correction: 340°C
Before correction: 750°C → After correction: 700°C
- (2) Find the sensor correction factor setting value from (1).
 $(Y' - X') / (Y - X) = (700 - 340) / (750 - 300) = 0.8$
- (3) It is input so that PV will be 300°C using a mV generator and dial resistor.
- (4) Set the value of (2) to the sensor correction factor.
- (5) Read PV.
It is displayed as 240°C.
- (6) Find the sensor correction setting value.
Find the difference between the PV after input correction and the PV read in (5).
 $340^\circ\text{C} - 240^\circ\text{C} = 100^\circ\text{C}$
- (7) Set the value of (6) to the sensor correction.
- (8) Input an electromotive force or resistance value equivalent to 750°C using a mV generator or dial resistor.
- (9) Read PV and check that the display is 700°C.

[Setting Example] When set Sensor correction factor: 0.800, Sensor correction: 100.0°C

0.800(0320H) [Slave address 1, Sensor correction factor of CH1]

- A request message from the master

Idle 3.5 characters	Slave address (01H)	Function code (06H)	Data item (0084H)	Data (0320H)	Error check CRC-16 (C8CBH)	Idle 3.5 characters
	1	1	2	2	2	

- Response message from the slave in normal status

Idle 3.5 characters	Slave address (01H)	Function code (06H)	Data item (0084H)	Data (0320H)	Error check CRC-16 (C8CBH)	Idle 3.5 characters
	1	1	2	2	2	

100.0°C (03E8H) [Slave address 1, Sensor correction of CH1]

- A request message from the master

Idle 3.5 characters	Slave address (01H)	Function code (06H)	Data item (0088H)	Data (03E8H)	Error check CRC-16 (095EH)	Idle 3.5 characters
	1	1	2	2	2	

- Response message from the slave in normal status

Idle 3.5 characters	Slave address (01H)	Function code (06H)	Data item (0084H)	Data (03E8H)	Error check CRC-16 (095EH)	Idle 3.5 characters
	1	1	2	2	2	

12.5 Auto/Manual Control Switch

Switching between Automatic control and Manual control is done by Auto/Manual control.

If control action is switched from automatic to manual and vice versa, balanceless-bumpless function works to prevent a sudden change in MV.

With Manual control, MV can be set arbitrarily. (*)

Set MV with Manual MV.

Manual control MV setting range: -5.0 to 105.0 %

When the instrument power supply is turned ON from OFF, it is restored with the control action selected by the power-on restoration action selection.

(*): If the sensor fails in manual control, the MV will be 0%.

[Setting Example] When set Auto/Manual control: Manual control, Manual MV: 20.0%

Manual control [Slave address 1, Auto/Manual control of CH1]

- A request message from the master

Idle 3.5 characters	Slave address (01H)	Function code (06H)	Data item (0010H)	Data (0001H)	Error check CRC-16 (49CFH)	Idle 3.5 characters
	1	1	2	2	2	

- Response message from the slave in normal status

Idle 3.5 characters	Slave address (01H)	Function code (06H)	Data item (0010H)	Data (0001H)	Error check CRC-16 (49CFH)	Idle 3.5 characters
	1	1	2	2	2	

20.0% (00C8H) [Slave address 1, Manual MV of CH1]

- A request message from the master

Idle 3.5 characters	Slave address (01H)	Function code (06H)	Data item (0014H)	Data (00C8H)	Error check CRC-16 (C858H)	Idle 3.5 characters
	1	1	2	2	2	

- Response message from the slave in normal status

Idle 3.5 characters	Slave address (01H)	Function code (06H)	Data item (0014H)	Data (00C8H)	Error check CRC-16 (C858H)	Idle 3.5 characters
	1	1	2	2	2	

13 Communication with PLC Using SIF Function

The SIF function (Smart InterFace, programless communication function) is a function that serially connects the PLC Q series (manufactured by Mitsubishi Electric Corp.) and this instrument, and reads and writes various data to and from PLC registers using the communication protocol of the PLC.

The following communication protocols and commands are supported.

Communication protocol	Format 4
Communication command	A compatible 1C frame AnA/AnU common command (QR/QW)

Using the console software (SWC-QTC101M), select the PLC register start number, PLC register address, the monitoring items and setting items to be linked, and set the specifications.

The control module QTC1-4P (with power supply / communication option) becomes the master, and the selected monitor item is periodically written to the PLC register by using the QW command, and the value of the PLC register is constantly updated.

In addition, the selected setting items are read from the PLC register in response to a setting request using the QR command.

When the read data is changed, the set value of control module QTC1-4P (with power supply / communication option), control module QTC1-40 (no power supply / communication option) or control module QTC1-20 (no power supply / communication option) is updated.

Configuration example of PLC and QTC1-4P, QTC1-40

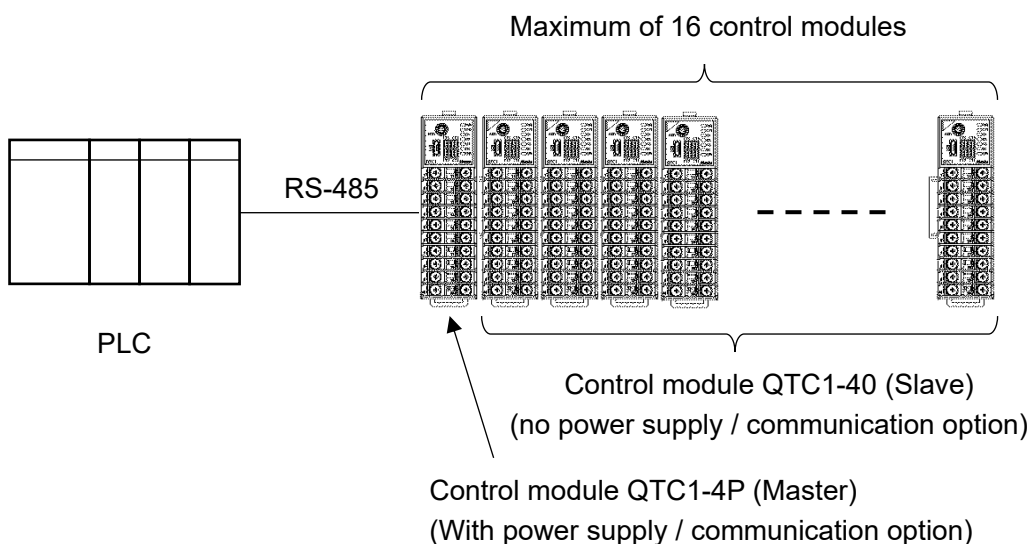

(Fig. 13-1)

13.1 Flow of Before Operation

The flow of operation when the QTC1-4P or QTC1-40 is connected to the PLC is shown below.

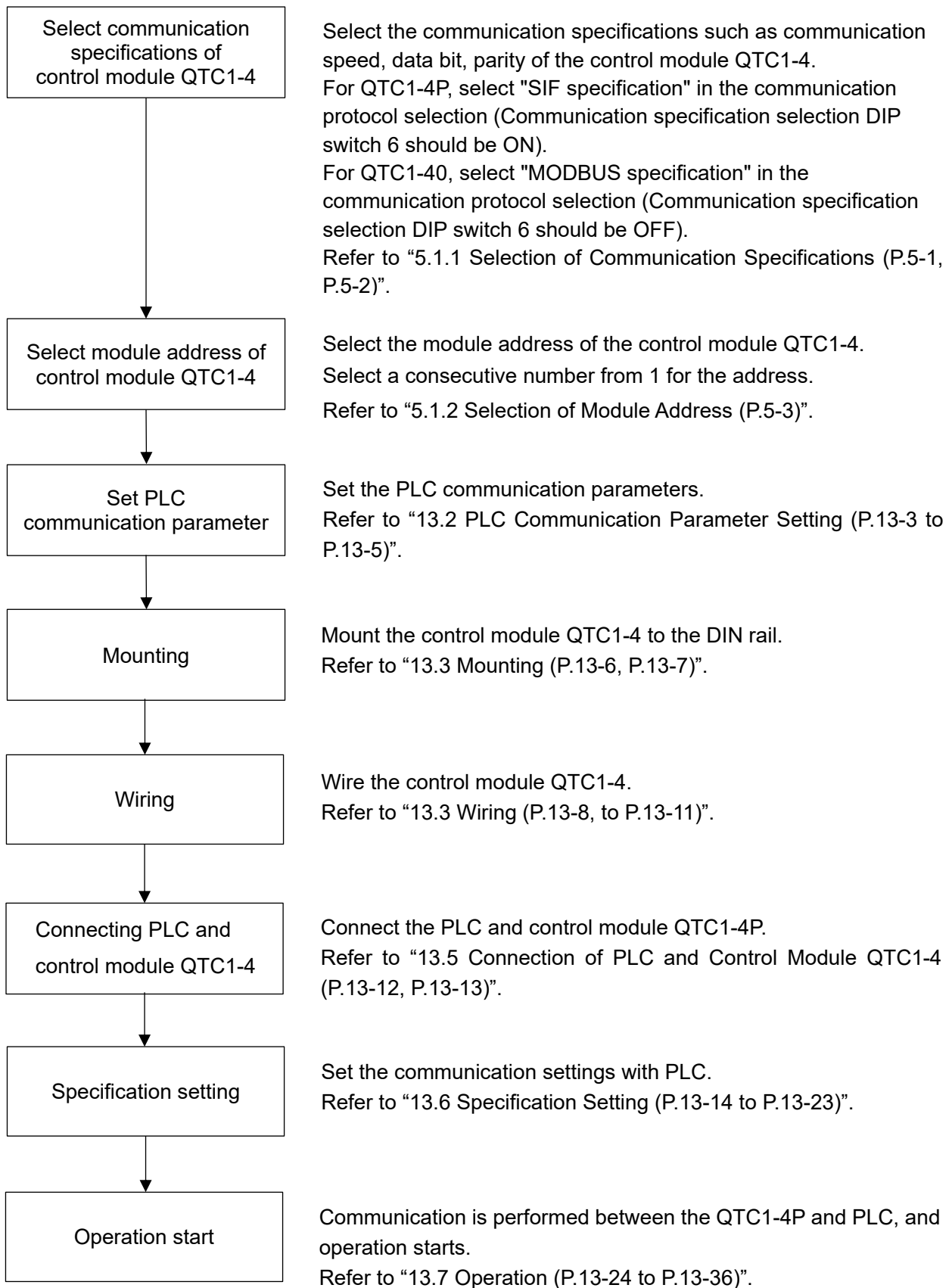

(Fig. 13.1-1)

13.2 PLC Communication Parameter Setting

Set the PLC communication parameters.

The setting method using GX Works3 is explained.

Connect the GX Works3 installed PC, set the communication speed, transmission specifications, communication protocol, etc., and then set the communication parameters using the PC write function. Refer to “Serial Communication Module User's Manual (Basic)” for detail.

(1) I/O assignment setting

Double-click [PLC parameter] on Project data list -> Parameter.

Display the parameter setting screen.

Click “I/O assignment setting” tab, and set “Type”, “Model Name” and “Point”.

The screenshot shows the 'Q Parameter Setting' dialog box with the 'I/O Assignment' tab selected. The 'I/O Assignment(*1)' table is as follows:

No.	Slot	Type	Model Name	Points	Start XY
0	PLC	PLC			
1	0(0-0)	Intelligent	QJ71C24N	32Points	
2	1(0-1)				
3	2(0-2)				
4	3(0-3)				
5	4(0-4)				
6	5(0-5)				
7	6(0-6)				

Below the table, there is a note: "Assigning the I/O address is not necessary as the CPU does it automatically. Leaving this setting blank will not cause an error to occur."

The 'Base Setting(*1)' section includes a table for Base Model Name, Power Model Name, Extension Cable, and Slots. The 'Main' row has '8' in the 'Slots' column. To the right, there are radio buttons for 'Auto' and 'Detail', and buttons for '8 Slot Default', '12 Slot Default', and 'Select module name'.

At the bottom, there are buttons for 'Export to CSV File', 'Import Multiple CPU Parameter', and 'Read PLC Data'. A note below these buttons states: "(*1)Setting should be set as same when using multiple CPU."

The dialog box has a standard Windows-style footer with buttons for 'Print Window...', 'Print Window Preview', 'Acknowledge XY Assignment', 'Default', 'Check', 'End', and 'Cancel'.

(Fig. 13.2-1)

[Setting Example]

Setting item	Setting contents
Type	Intelligent
Model Name	Model name of mounted unit (Example: QJ71C24N)
Point	32 points

(2) Switch setting

Click [Switch setting] button to the right of the I/O assignment setting.

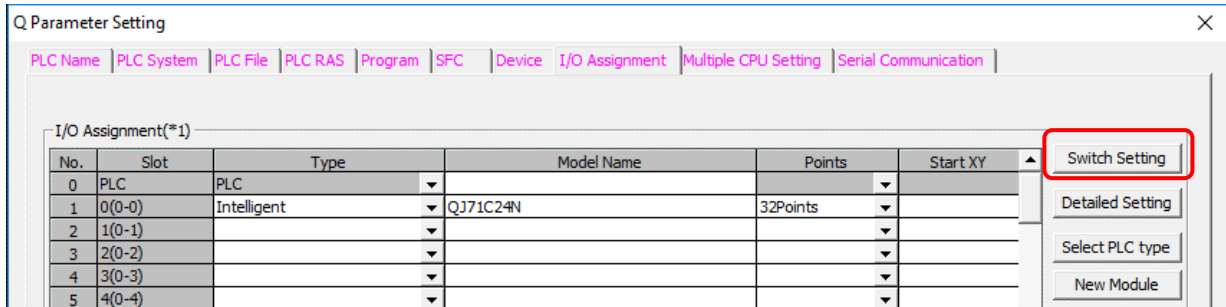

(Fig. 13.2-2)

Displays the Switch setting for I/O and intelligent function module screen.

Set the data bit, parity bit, stop bit, communication speed and communication protocol settings.

After setting, click [End] button.

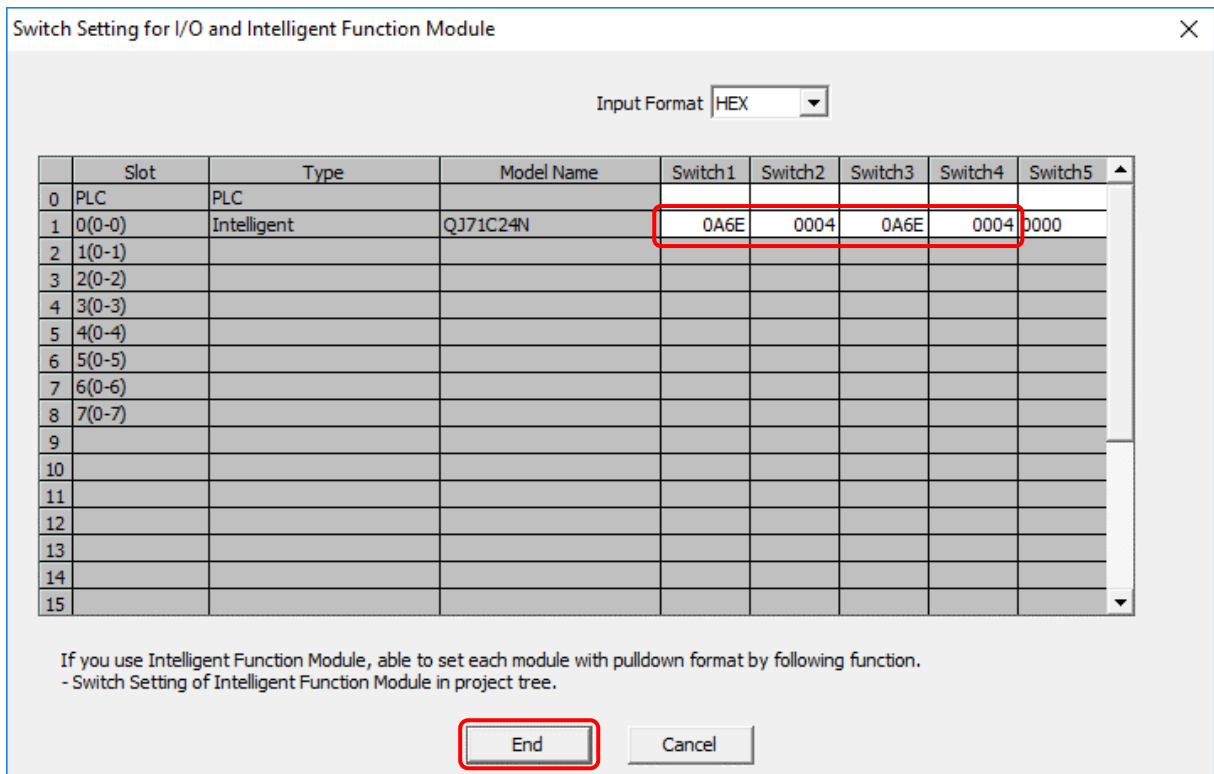

(Fig. 13.2-3)

[Setting Example]

Setting item	Setting contents
Action setting	Independent
Data bit	8 bits
Parity bit	Even
Stop bit	1 bit
Sum check code	Yes
Write during RUN	Enable
Setting change	Disable
Communication speed setting	Set the same communication speed as the control module QTC1-4 (Setting example: 57600 bps)
Communication protocol setting	Format 4

(3) PLC writing

Click [Write to PLC...] on Menu bar -> Online.

Display the PC writing screen.

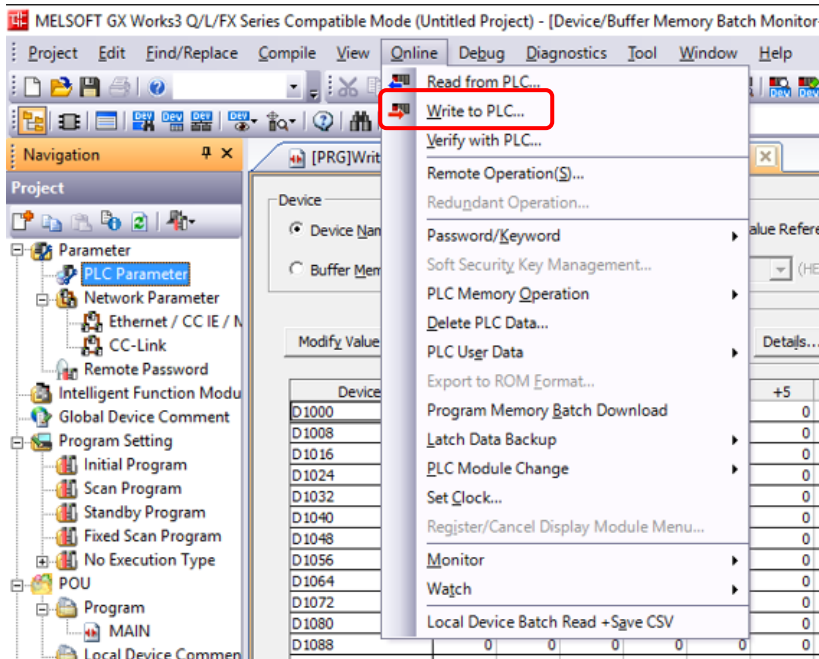

(Fig. 13.2-4)

Click [Select all] button -> [Execute] button.

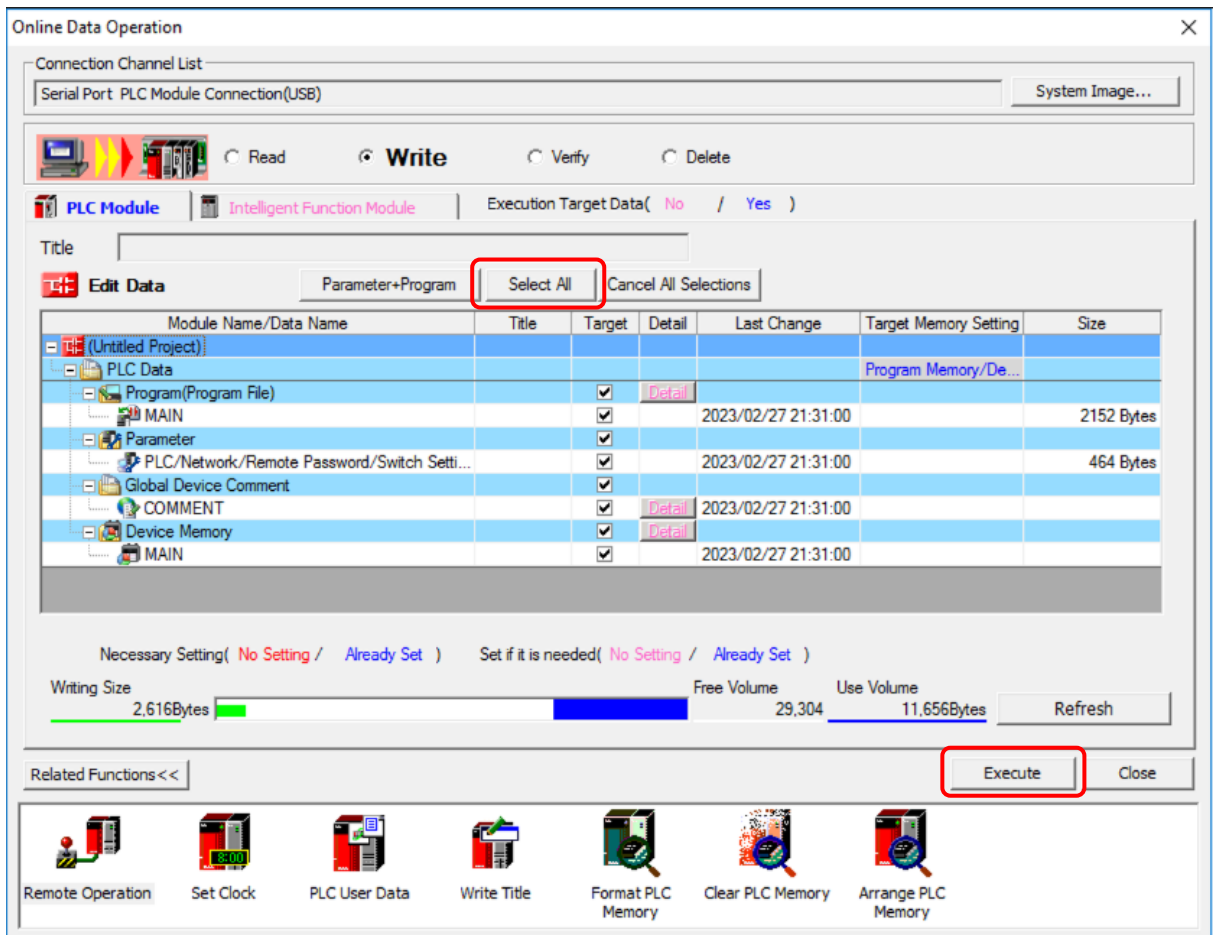

(Fig. 13.2-5)

This completes the PLC communication parameter settings.

13.3 Mounting

Mounting to the DIN rail

- ① Lower the lock lever of this instrument. (The lock lever of this instrument has a spring structure, but if lower it in the direction of the arrow until it stops, it will be locked in that position.)
- ② Hook the part ② of this instrument onto the top of the DIN rail.
- ③ Insert the lower part of this instrument with the part ② as a fulcrum.
- ④ Raise the lock lever of this instrument.
Make sure it is fixed to the DIN rail.

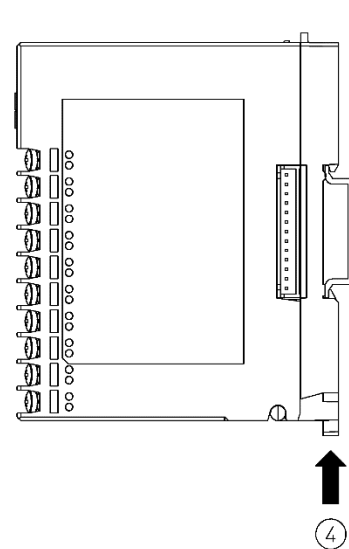
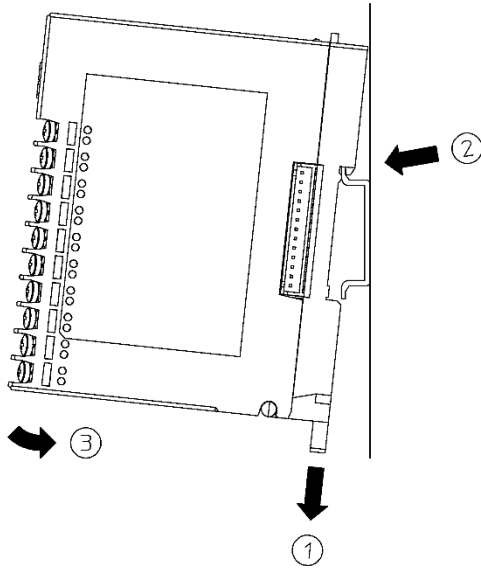

Removal from the DIN rail

- ① Insert a flat blade screwdriver into the lock lever of this instrument and lower the lock lever until it stops.
- ② Remove this instrument from the DIN rail by lifting it from below.

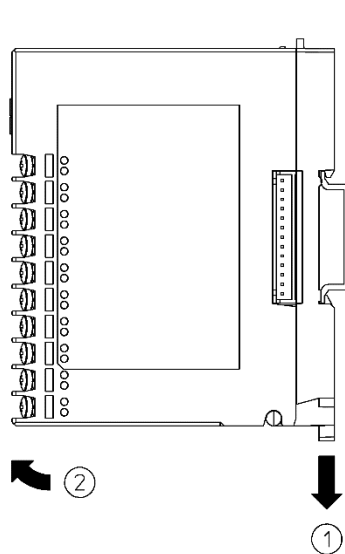

Mounting multiple modules to the DIN rail

This section describes an example of mounting multiple control modules QTC-4 on the DIN rail.

- ① Remove the line cap on the right side of the QTC1-4P.
- ② Lower the lock lever of the QTC1-40, and mounting the QTC1-40 to the DIN rail.
- ③ Slide the QTC1-40 to the left and connect the connectors to each other.
- ④ Raise the lock lever of this instrument.
Make sure it is fixed to the DIN rail.

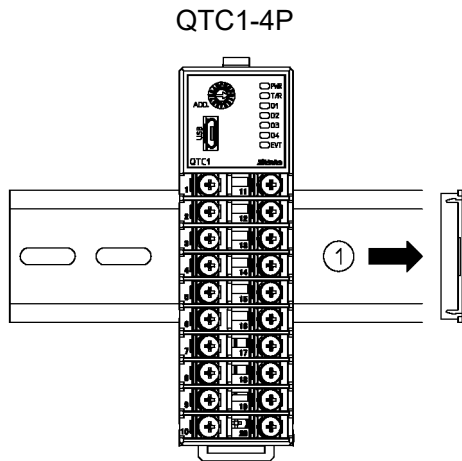

(Fig. 13.3-4)

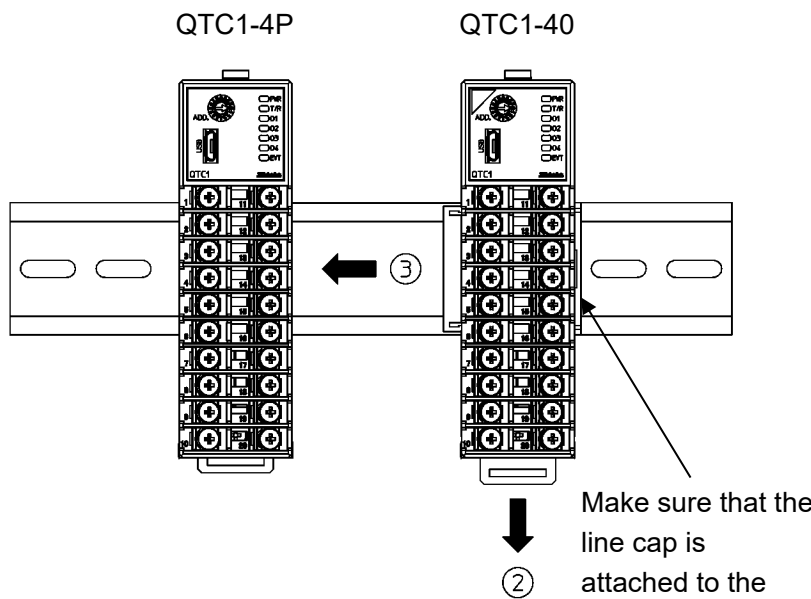

(Fig. 13.3-5)

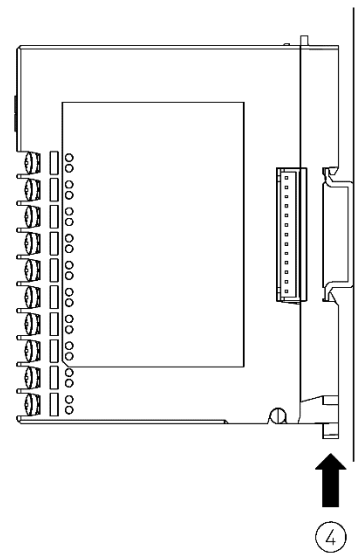

(Fig. 13.3-6)

13.4 Wiring

13.4.1 Wiring for Power Supply and Serial Communication

The terminal block for power supply and serial communication is located on the base of this instrument.

Wiring by the following procedure.

(1) Case removal

- ① Push the release lever on the top of this instrument to unlock it.
- ② Remove the case.

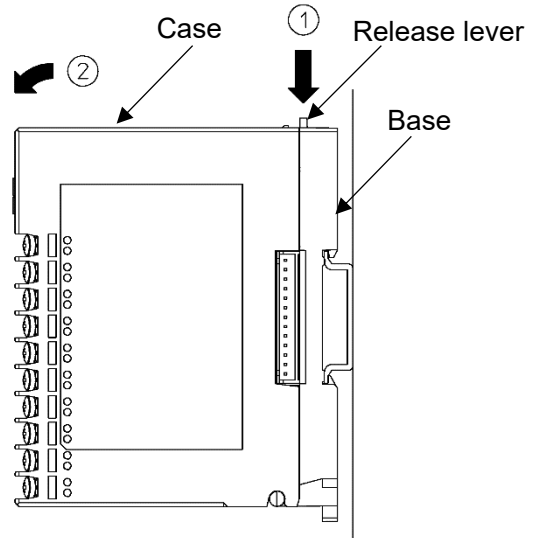

(Fig. 13.4.1-1)

(2) Wiring

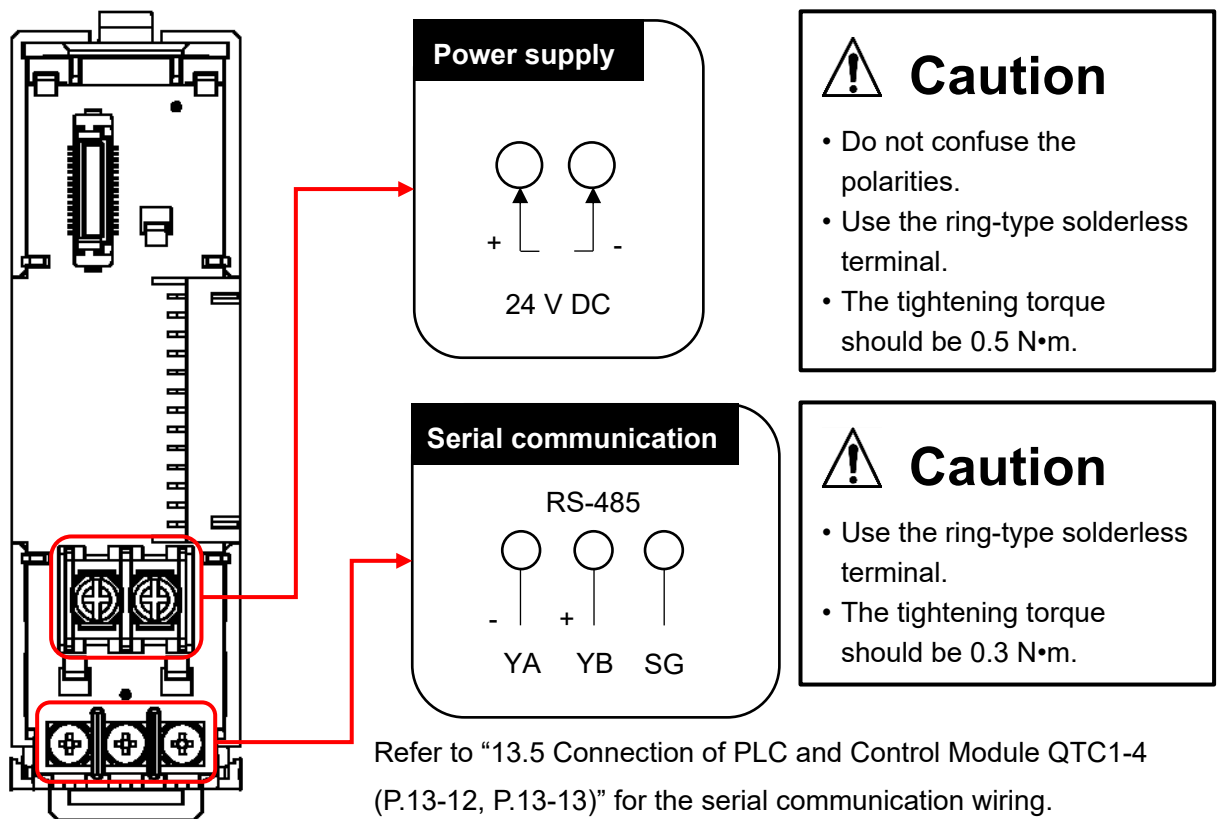

(Fig. 13.4.1-2)

(3) Case mounting

- ① Hook the case on the lower part ① of this instrument.
- ② Mount the case so that the lower part ① of this instrument is the fulcrum and covers the release lever. There is a clicking sound.

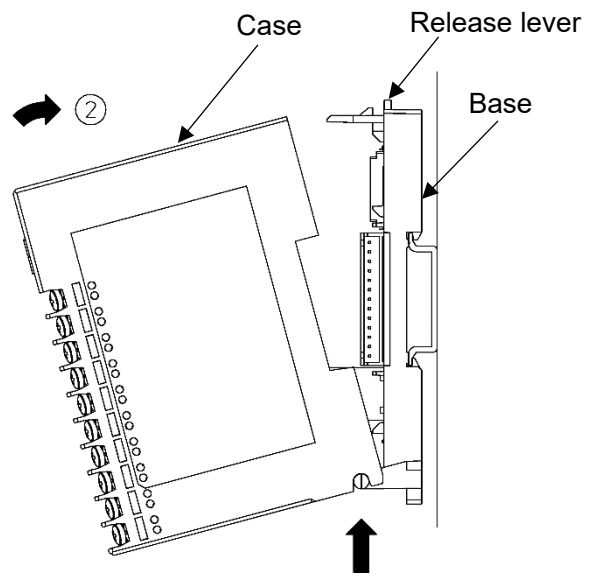

①
(Fig. 13.4.1-3)

13.4.2 Wiring for Input, Output and CT

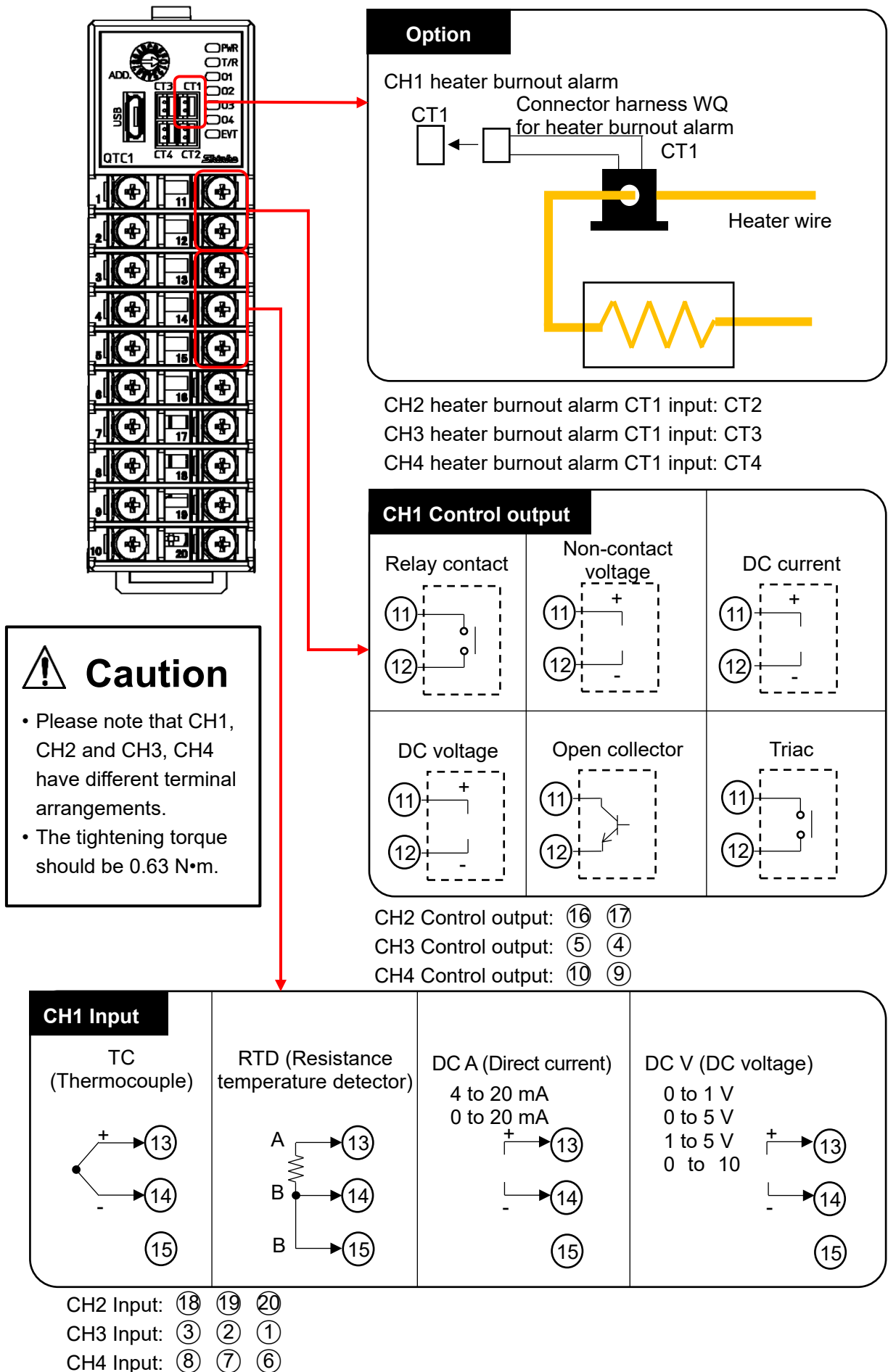

(Fig. 13.4.2-1)

13.4.3 Wiring for Event Input and Event Output

Using the connector harness EVQ for event input/output.

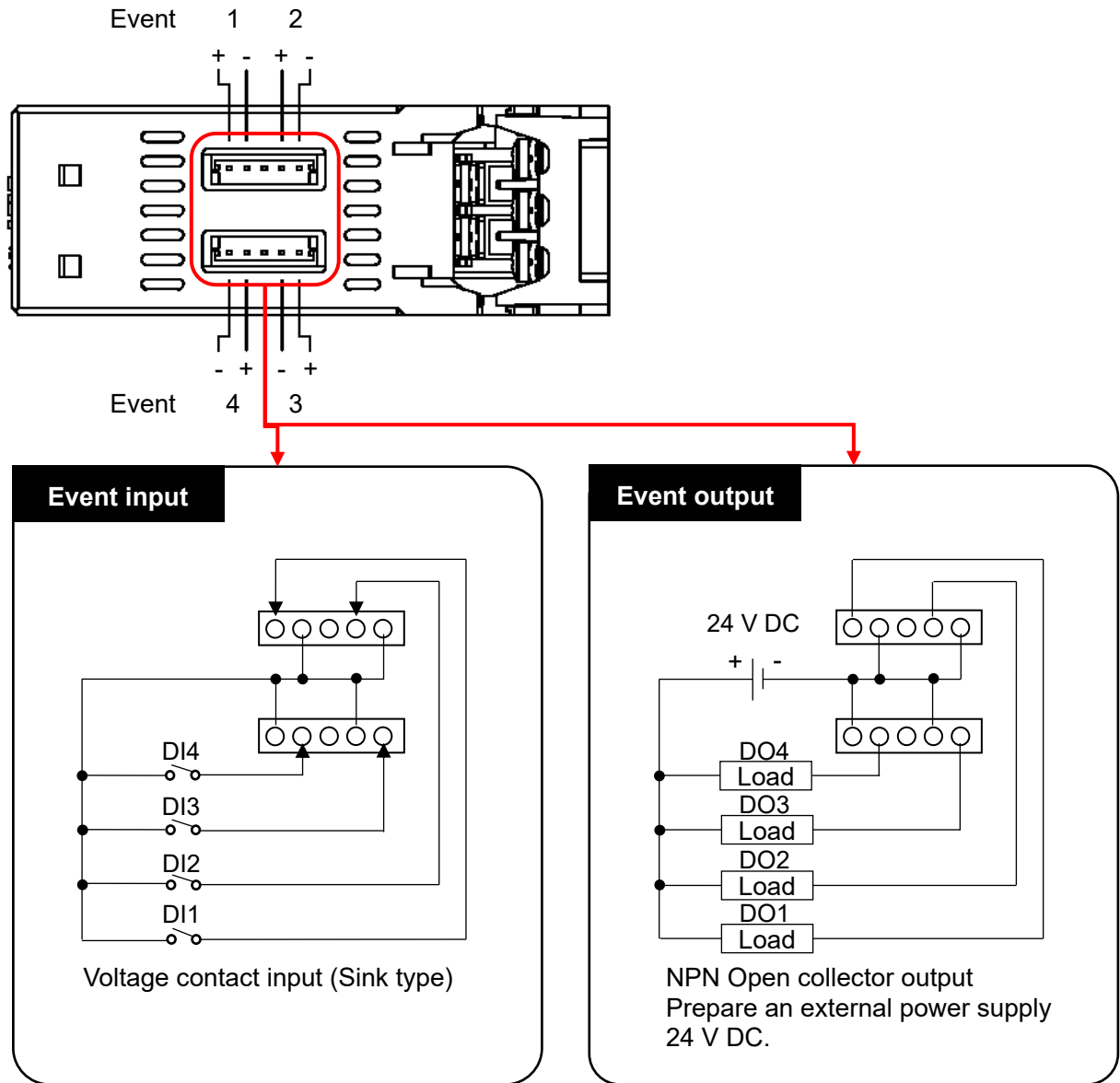

(Fig. 13.4.3-1)

13.5 Connection of PLC and Control Module QTC1-4

Warning

Turn off the power supply to this instrument before wiring.

If you work while the power is supplied, you may get an electric shock, which could result in an accident resulting in death or serious injury.

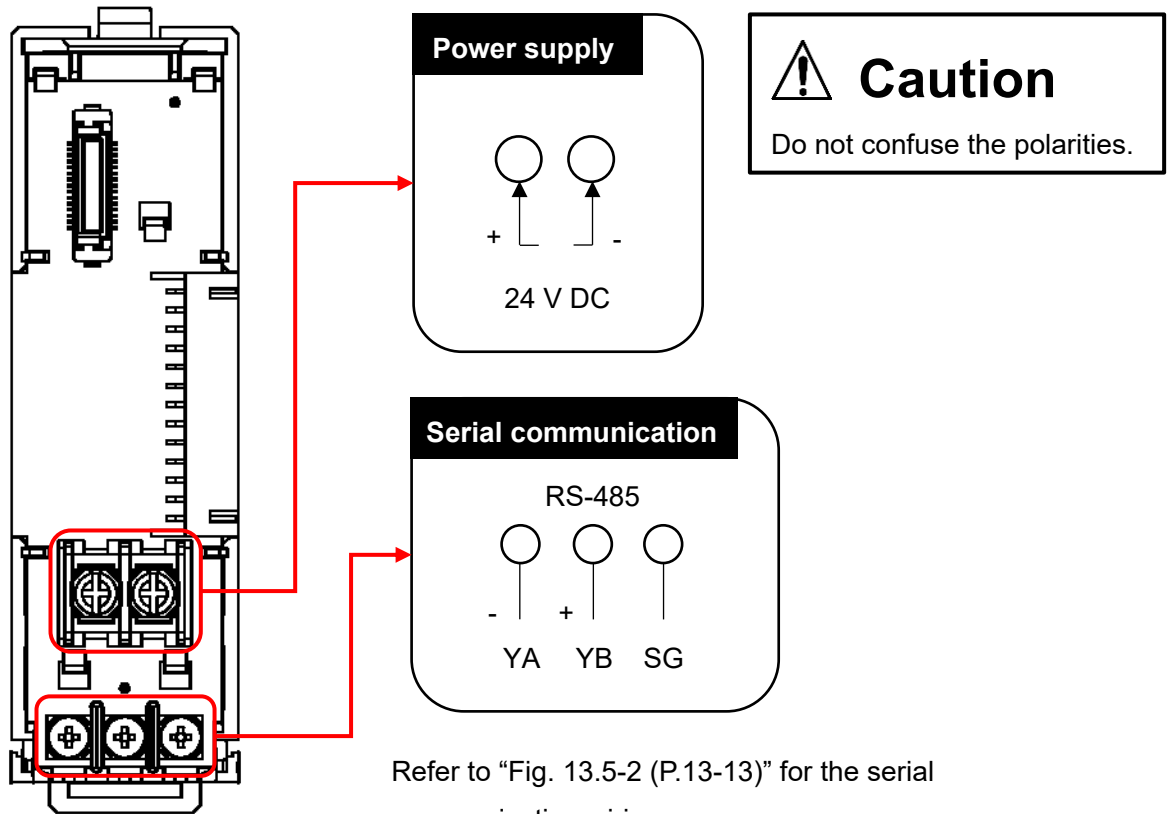

Refer to "Fig. 13.5-2 (P.13-13)" for the serial communication wiring.

(Fig. 13.5-1)

Example of connection between PLC and QTC1-4P, QTC1-40

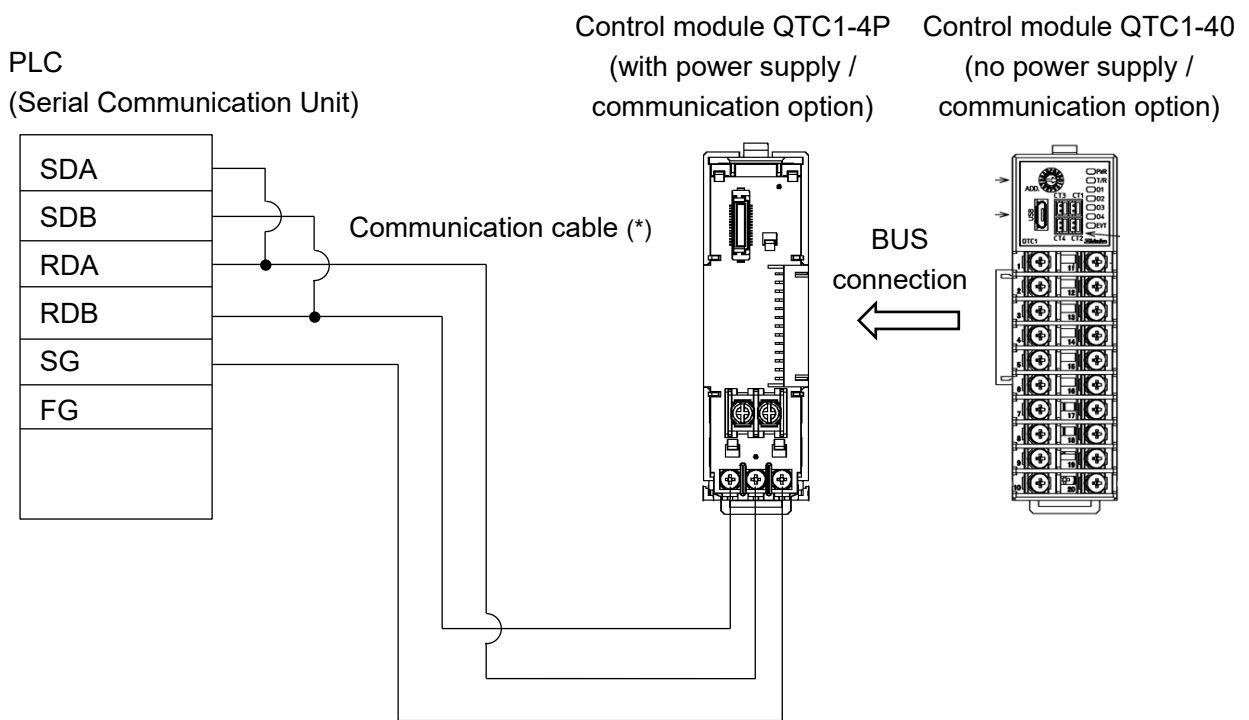

(*): For communication cables, please contact the store where you purchased the product or our sales office.

(Fig. 13.5-2)

13.6 Specification Setting

Set the specifications of the control module to communicate with the PLC.

This section describes how to set specifications using console software (SWC-QTC101M).

13.6.1 Preparation of USB Communication Cable and Console Software

Please prepare the USB communication cable and the console software.

- USB communication cable
USB-micro USB Type-B (commercial item)

- Console software (SWC-QTC101M)
Please download from our website and install.

Click <https://shinko-technos.co.jp/e/> → Support/Download → Software

13.6.2 Connecting to Host Computer



Caution

Do not use the logging function of the console software when communicating by connecting the USB communication cable.

- (1) Connect the micro USB Type-B side of the USB communication cable to the console communication connector of this instrument.
- (2) Connect the USB plug of the USB communication cable to the USB port of the host computer.

Example of connection between host computer and QTC1-4P, QTC1-40

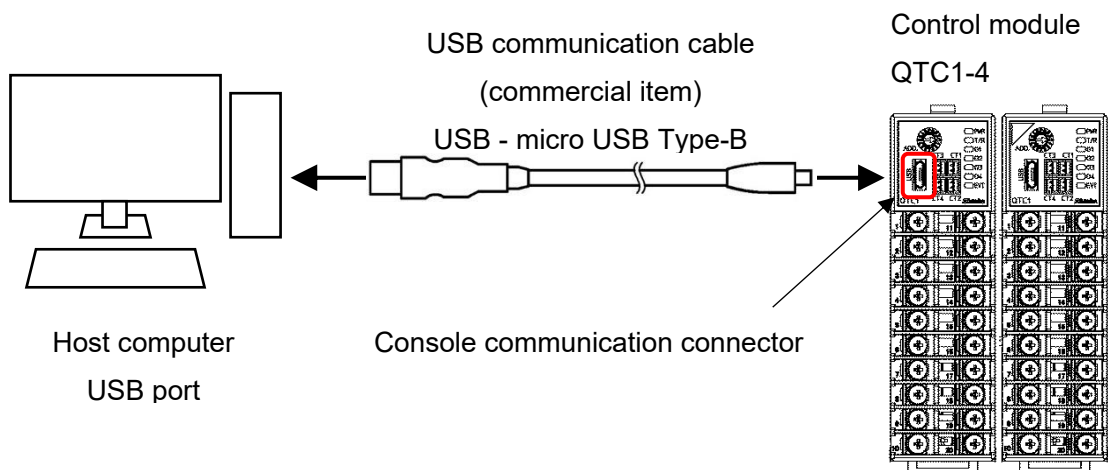

(Fig. 13.6.2-1)

(3) Checking the COM port number

Follow the procedure below to check the COM port number.

- ① Right-click “Start” → Click “Device manager” from menu.
- ② When “USB Serial Port (COM3)” is displayed in “Port (COM and LPT)”, the COM port is assigned to No. 3.
Check the COM port number, and then close “Device Manager”.

(4) Starting the console software (SWC-QTC101M)

- ① Start the console software (SWC-QTC101M).
Select “QTC1-4” in the Device selection.

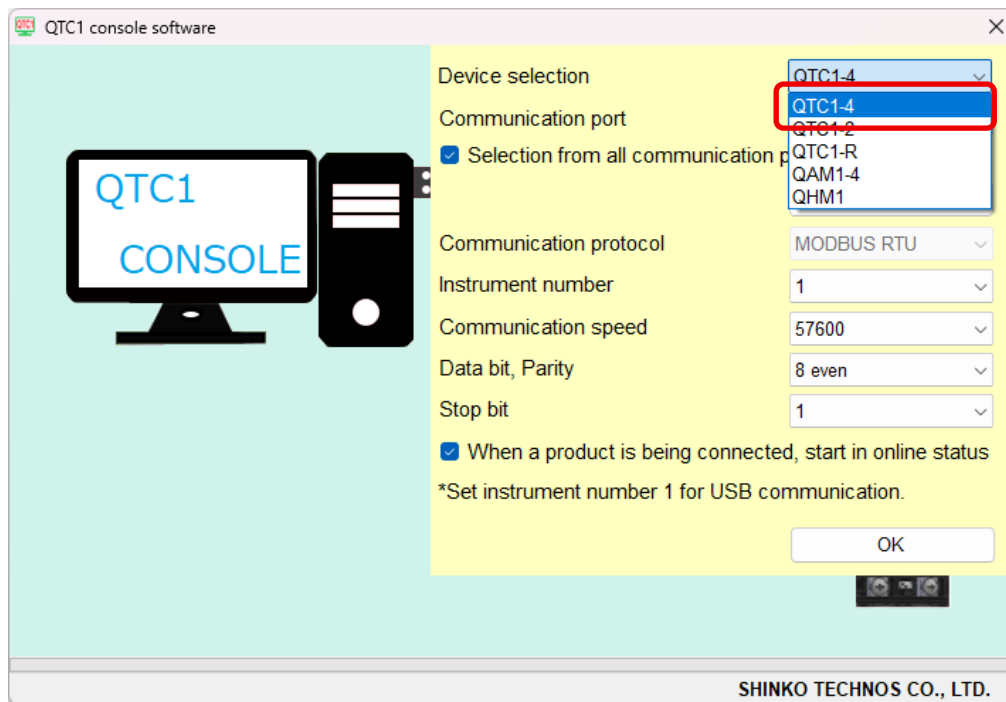

(Fig. 13.6.2-2)

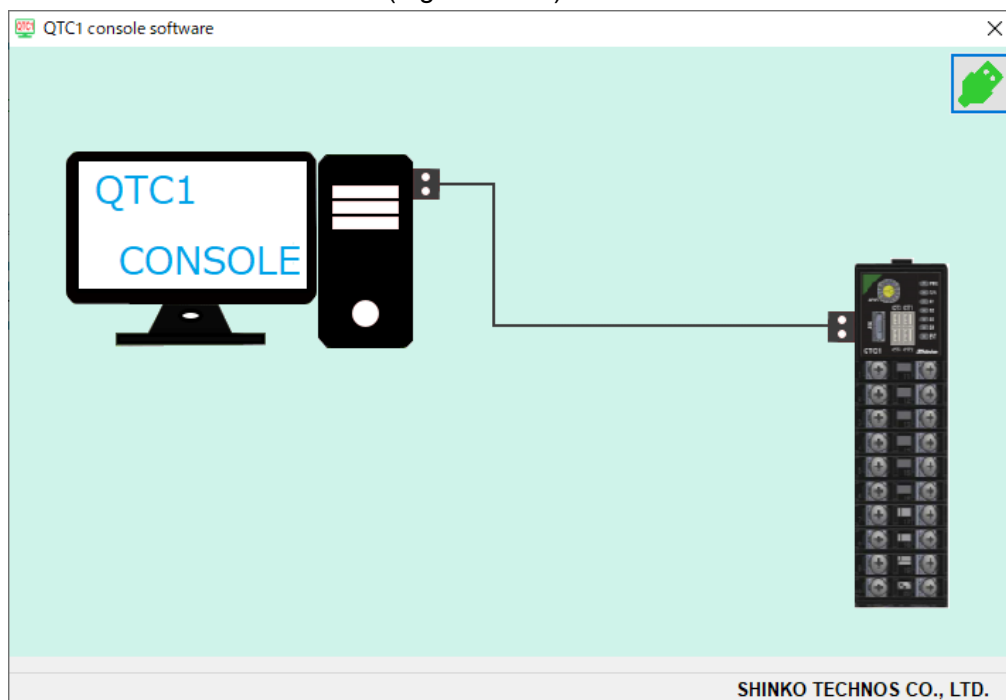

(Fig. 13.6.2-3)

- ② Click [User (U)] on the menu bar → [Communication condition (C)].
Display the communication condition setting screen.

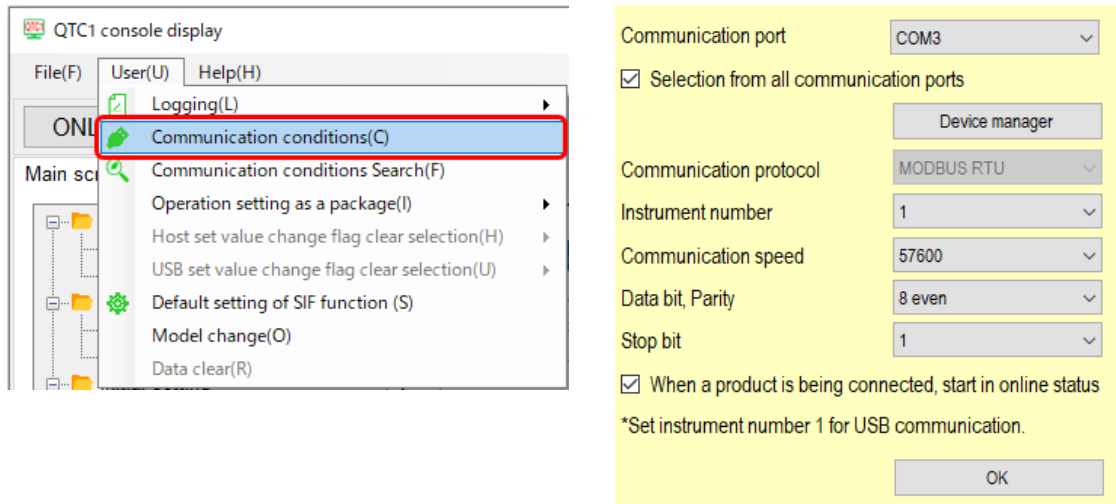

(Fig. 13.6.2-4)

※*The model “QTC1-4” can also be selected from User (U) - Model change (o) in the menu bar.

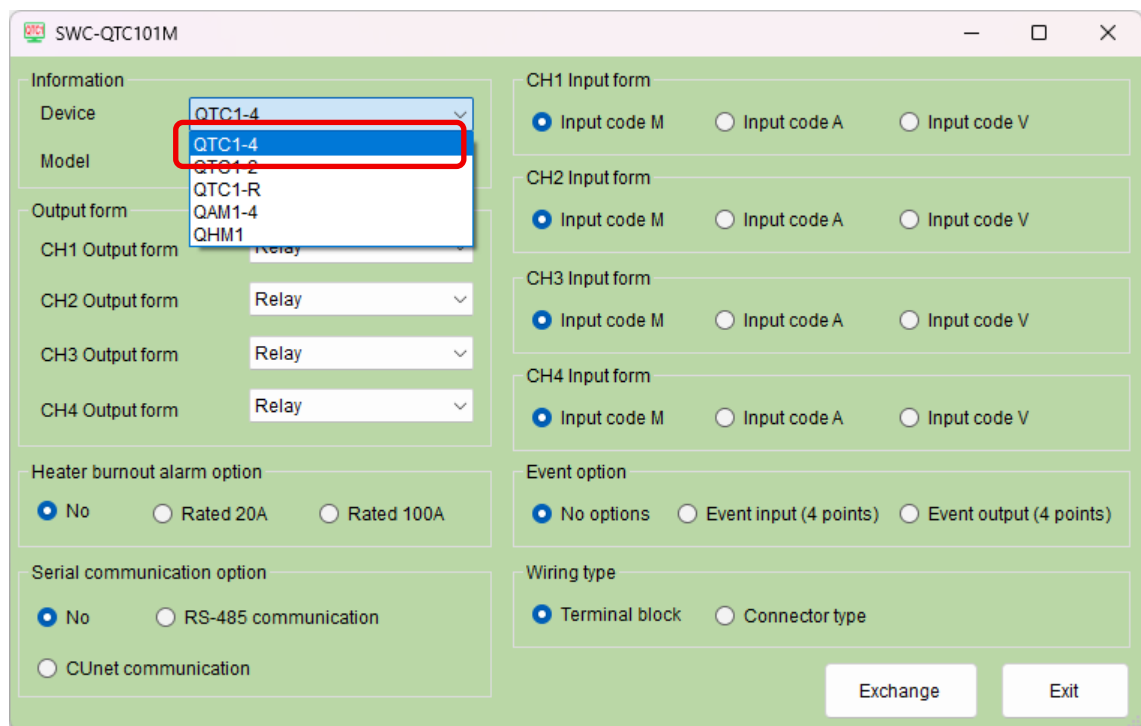

(Fig. 13.6.2-5)

- ③ Set the communication condition as shown below.

Setup Items	Setting Value
Communication port	Select the COM port number confirmed in ② of (3).
Communication protocol	MODBUS RTU

- ④ Click [OK]

- ⑤ Click “Default setting of SIF function(S)” from “User(U)” of menu ber.
Display “Default setting of SIF function” screen.

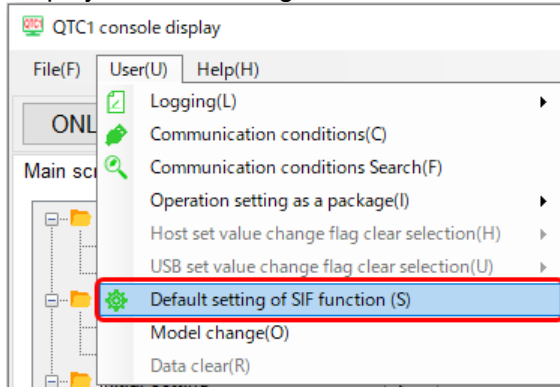

(Fig. 13.6.2-6)

- ⑥ Select “Module 1” and click “System” tab.

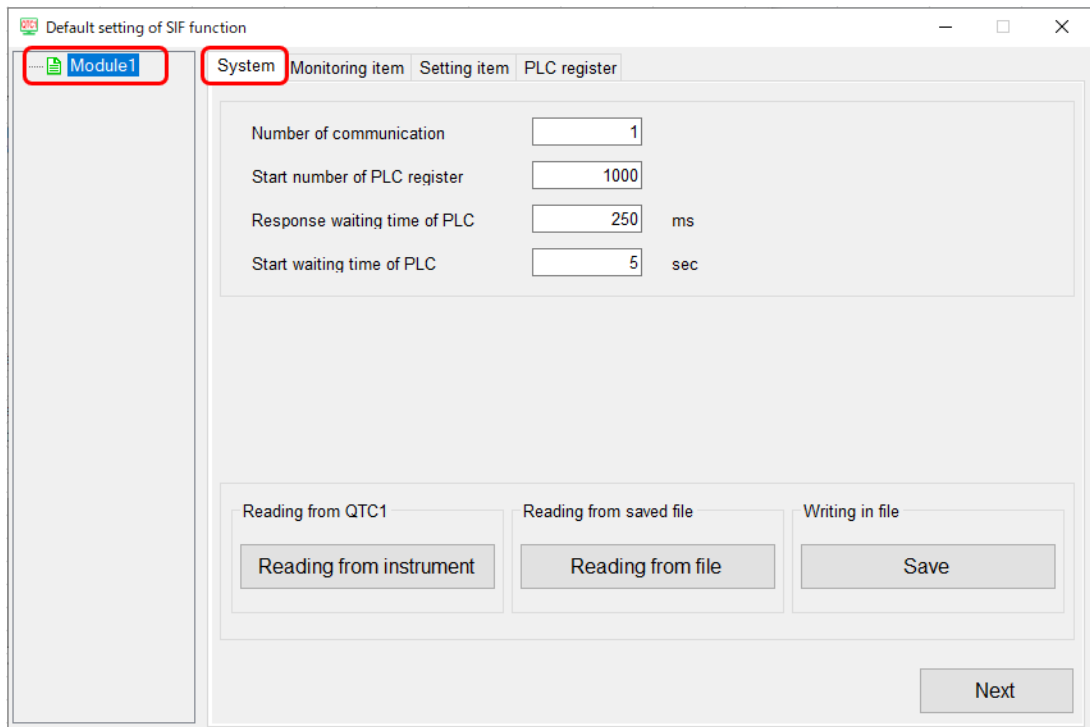

(Fig. 13.6.2-7)

The specifications are ready.

13.6.3 Specification Setting

SIF function initial setting screen

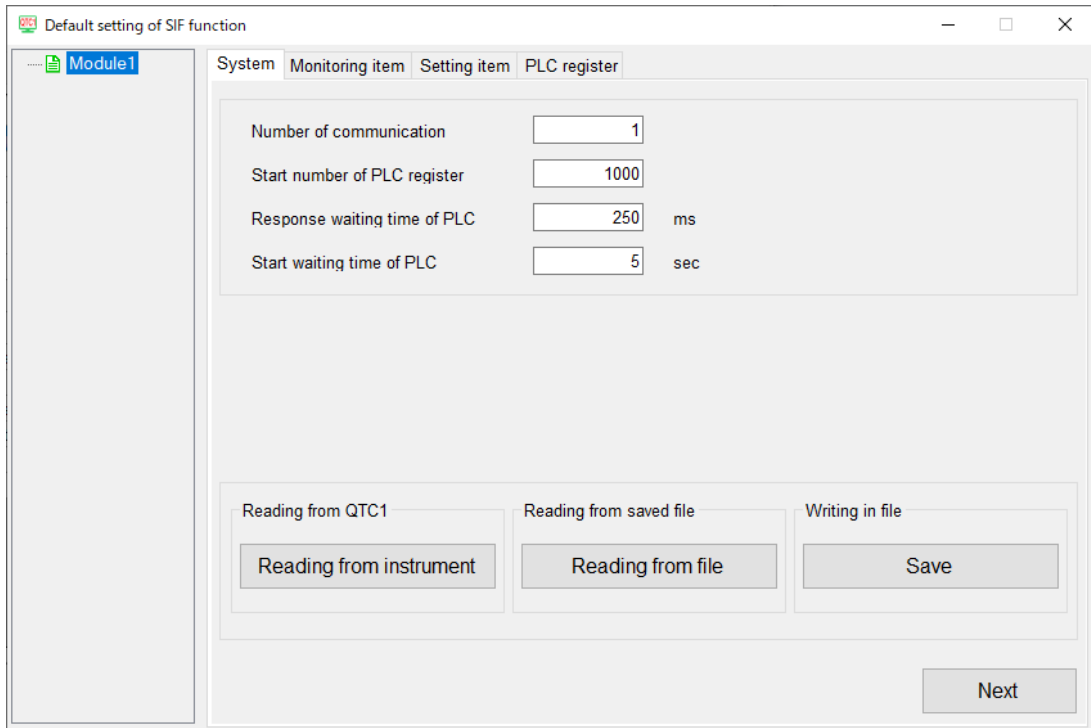

(Fig. 13.6.3-1)

Set the specifications referring to the SIF function initial setting items.

SIF function initial setting items

MODBUS address		Name	Settings • Selection range	Initial value	Remarks (*)
HEX	DEC				
020A	522	Communication management module number setting	1 to 16 modules	1	1
0384	900	PLC register start number	0 to 65535	1000	0
0385	901	PLC response wait time	100 to 3000 ms	250	1
0386	902	PLC communication start wait time	1 to 255 seconds	5	1
0387	903	Reservation (Not used)		0	0
0388	904	Reservation (Not used)		0	0
0389	905	Monitor item 1	Refer to Monitor item 1 (P.13-18)	31	0
038A	906	Monitor item 2	Refer to Monitor item 2 (P.13-19)	0	0
038B	907	Monitor item 3	Refer to Monitor item 3 (P.13-19)	0	0
038C	908	Reservation (Not used)		0	0
038D	909	Reservation (Not used)		0	0
038E	910	Setting item 1	Refer to Setting item 1 (P.13-20)	57827	0
038F	911	Setting item 2	Refer to Setting item 2 (P.13-20)	2721	0
0390	912	Setting item 3	Refer to Setting item 3 (P.13-21)	0	0
0391	913	Setting item 4	Refer to Setting item 4 (P.13-21)	0	0
0392	914	Setting item 5	Refer to Setting item 5 (P.13-22)	0	0
0393	915	Setting item 6	Refer to Setting item 6 (P.13-22)	0	0
0394	916	Setting item 7	Refer to Setting item 7 (P.13-23)	0	0

(*) 0: The value set in each control module QTC1-4 is a valid item.

1: The value set in the control module QTC1-4P is a valid item.

- (1) Communication management module number setting
Set the number of modules managed by the master module.
Set the number of modules including the master module.

- (2) PLC register start number
Set the start number of the register used in PLC communication. It is fixed to the D register.
Please set in the range of 0 to 65535.
For A compatible 1C frame AnA/AnU, set within the range of 0 to 8191.
A maximum of 170 registers are used per control module. [System area: 10 registers, Monitor item: 80 registers (20 × 4ch), Setting item: 80 registers (20 × 4ch)]
When using multiple control modules, be careful not to duplicate them.

- (3) PLC response wait time
Set the retransmission interval time when there is no response from the PLC.
Please set in the range of 100 to 3000 ms.

- (4) PLC communication start wait time
Set the time from when the control module QTC1-4P power is turned on until communication is started to the PLC.
Please set in the range of 1 to 255 seconds.

- (5) Monitor item 1 to 3
Click [Monitor item] tab or [Next] button.
Displays the Monitor item screen.
Select any of Monitor item 1 to 3. The maximum number of valid item selections is 20.
The excess is invalid for all channels in the control module.

Monitor item 1 (Initial value: 31)

Bit	No.	Selection	Description
0	01	1	PV reading (including difference)
1	02	1	MV reading
2	03	1	SV reading
3	04	1	Status flag 1 reading
4	05	1	Status flag 2 reading
5	06	0	Heater current value reading
6	07	0	Event input reading
7	08	0	Event output reading
8	09	0	PV reading (true value)
9	10	0	Ambient temperature reading
10	11	0	Not used
11	12	0	Not used
12	13	0	Not used
13	14	0	Not used
14	15	0	Not used
15	16	0	Not used

Monitor item 2 (Initial value: 0)

Bit	No.	Selection	Description
0	17	0	Alarm history 1 Error No.
1	18	0	Alarm history 2 Error No.
2	19	0	Alarm history 3 Error No.
3	20	0	Alarm history 4 Error No.
4	21	0	Alarm history 5 Error No.
5	22	0	Alarm history 6 Error No.
6	23	0	Alarm history 7 Error No.
7	24	0	Alarm history 8 Error No.
8	25	0	Alarm history 9 Error No.
9	26	0	Alarm history 10 Error No.
10	27	0	Alarm history 1 Total energizing time
11	28	0	Alarm history 2 Total energizing time
12	29	0	Alarm history 3 Total energizing time
13	30	0	Alarm history 4 Total energizing time
14	31	0	Alarm history 5 Total energizing time
15	32	0	Alarm history 6 Total energizing time

Monitor item 3 (Initial value: 0)

Bit	No.	Selection	Description
0	33	0	Alarm history 7 Total energizing time
1	34	0	Alarm history 8 Total energizing time
2	35	0	Alarm history 9 Total energizing time
3	36	0	Alarm history 10 Total energizing time
4	37	0	Contact switching total number of times (High)
5	38	0	Contact switching total number of times (Low)
6	39	0	Total energizing time (High, Low)
7	40	0	Heater accumulated energizing time (High)
8	41	0	Heater accumulated energizing time (Low)
9	42	0	Not used
10	43	0	Not used
11	44	0	Not used
12	45	0	Not used
13	46	0	Not used
14	47	0	Not used
15	48	0	Not used

(6) Setting item 1 to 7

Click [Setting item] tab or [Next] button.

Displays the Setting item screen.

Select any of Setting item 1 to 7. The maximum number of valid item selections is 20.

The excess is invalid for all channels in the control module.

Setting item 1 (Initial value: 57827)

Bit	Setting request item number	Selection	Description
0	1	1	Control Allowed/Prohibited selection
1	2	1	AT Perform/Cancel selection
2	3	0	Event output ON/OFF selection
3	4	0	Auto/Manual control selection
4	5	0	Manual MV setting
5	6	1	SV setting
6	7	1	Proportional band setting
7	8	1	Integral time setting
8	9	1	Derivative time setting
9	10	0	Proportional cycle setting
10	11	0	ON/OFF hysteresis setting
11	12	0	Output high limit setting
12	13	0	Output low limit setting
13	14	1	Alarm 1 action selection
14	15	1	Alarm 2 action selection
15	16	1	Alarm 3 action selection

Setting item 2 (Initial value: 2721)

Bit	Setting request item number	Selection	Description
0	17	1	Alarm 4 action selection
1	18	0	Alarm 1 hysteresis setting
2	19	0	Alarm 2 hysteresis setting
3	20	0	Alarm 3 hysteresis setting
4	21	0	Alarm 4 hysteresis setting
5	22	1	Alarm 1 value setting
6	23	0	Alarm 1 high limit value setting
7	24	1	Alarm 2 value setting
8	25	0	Alarm 2 high limit value setting
9	26	1	Alarm 3 value setting
10	27	0	Alarm 3 high limit value setting
11	28	1	Alarm 4 value setting
12	29	0	Alarm 4 high limit value setting
13	30	0	Heater burnout alarm setting
14	31	0	Loop break alarm band setting
15	32	0	Loop break alarm time setting

Setting item 3 (Initial value: 0)

Bit	Setting request item number	Selection	Description
0	33	0	Sensor correction factor setting
1	34	0	Sensor correction setting
2	35	0	PV filter time constant setting
3	36	0	SV rise rate setting
4	37	0	SV fall rate setting
5	38	0	MV bias setting
6	39	0	Not used
7	40	0	Not used
8	41	0	Not used
9	42	0	Not used
10	43	0	Not used
11	44	0	Not used
12	45	0	Not used
13	46	0	Not used
14	47	0	Not used
15	48	0	Not used

Setting item 4 (Initial value: 0)

Bit	Setting request item number	Selection	Description
0	49	0	Input type selection
1	50	0	Temperature unit selection
2	51	0	Scaling high limit setting
3	52	0	Scaling low limit setting
4	53	0	Input sampling selection
5	54	0	Direct/Reverse action selection
6	55	0	AT action mode selection
7	56	0	AT bias setting
8	57	0	ATgain setting
9	58	0	Alarm 1 value 0 Enabled/Disabled selection
10	59	0	Alarm 2 value 0 Enabled/Disabled selection
11	60	0	Alarm 3 value 0 Enabled/Disabled selection
12	61	0	Alarm 4 value 0 Enabled/Disabled selection
13	62	0	Event output allocation selection
14	63	0	Event input allocation selection
15	64	0	CH Enabled/Disabled selection

Setting item 5 (Initial value: 0)

Bit	Setting request item number	Selection	Description
0	65	0	Number of moving average setting
1	66	0	Input math function selection
2	67	0	Input difference selection
3	68	0	Input difference setting
4	69	0	Control action selection
5	70	0	Proportional gain 2 DOF coefficient (α) setting
6	71	0	Integral 2 DOF coefficient (β) setting
7	72	0	Derivative 2 DOF coefficient (γ , Cd) setting
8	73	0	Desired value proportional coefficient (Cp) setting
9	74	0	Gap width setting
10	75	0	Gap coefficient setting
11	76	0	Output minimum ON/OFF time setting
12	77	0	Integral/Derivative decimal point position selection
13	78	0	Power-on restore action selection
14	79	0	Proportional band decimal point position selection
15	80	0	Not used

Setting item 6 (Initial value: 0)

Bit	Setting request item number	Selection	Description
0	81	0	Control function selection
1	82	0	Cooling P-band setting
2	83	0	Cooling Integral time setting
3	84	0	Cooling Derivative time setting
4	85	0	Cooling proportional cycle setting
5	86	0	Cooling ON/OFF hysteresis setting
6	87	0	Overlap/Dead band setting
7	88	0	Cooling output high limit setting
8	89	0	Cooling output low limit setting
9	90	0	Cooling action mode selection
10	91	0	Slave scale high limit setting
11	92	0	Slave scale low limit setting
12	93	0	Output bias setting
13	94	0	Output gain setting
14	95	0	Output channel selection
15	96	0	Output rate-of-change setting

Setting item 7 (Initial value: 0)

Bit	Setting request item number	Selection	Description
0	97	0	Communication response delay time setting
1	98	0	Extension function selection
2	99	0	Total current setting
3	100	0	Current value setting
4	101	0	OUT ON delay setting
5	102	0	Auto balance control Interlock/Single selection
6	103	0	Auto balance control Master/Slave selection
7	104	0	Auto balance control Enabled/Disabled selection
8	105	0	Auto balance control start output setting
9	106	0	Auto balance control cancel area setting
10	107	0	Number of communication management module setting
11	108	0	Non-volatile IC memory save selection
12	109	0	Control action selection when input error
13	110	0	Output manipulated variable setting when input error
14	111	0	Not used
15	112	0	Not used

(7) Control module power OFF → ON

Turn the control module power off and then on. The set value becomes effective.

This completes the specification setting.

If multiple control modules are connected, connect the USB communication cable to the next control module.

Click User (U) - Model change (o) in the menu bar.

This will display the Change Model screen.

Select "QTC1-4" and click the [Exchange] button.

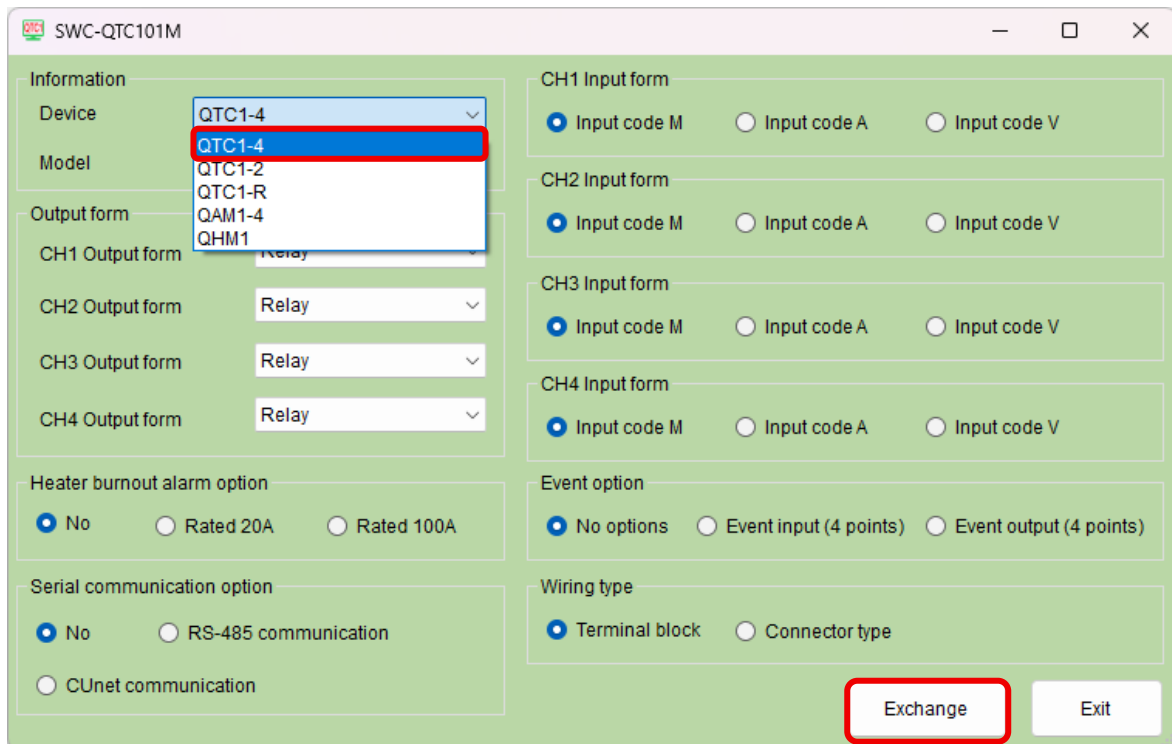

(Fig. 13.6.3-2)

Click "Default setting of SIF function(S)" from "User(U)" of menu ber.

Display "Default setting of SIF function" screen.

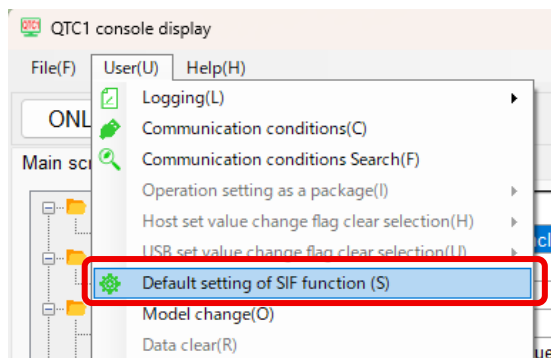

(Fig. 13.6.3-3)

Select the connected module number (Example: Module 2) and click the [System] tab.

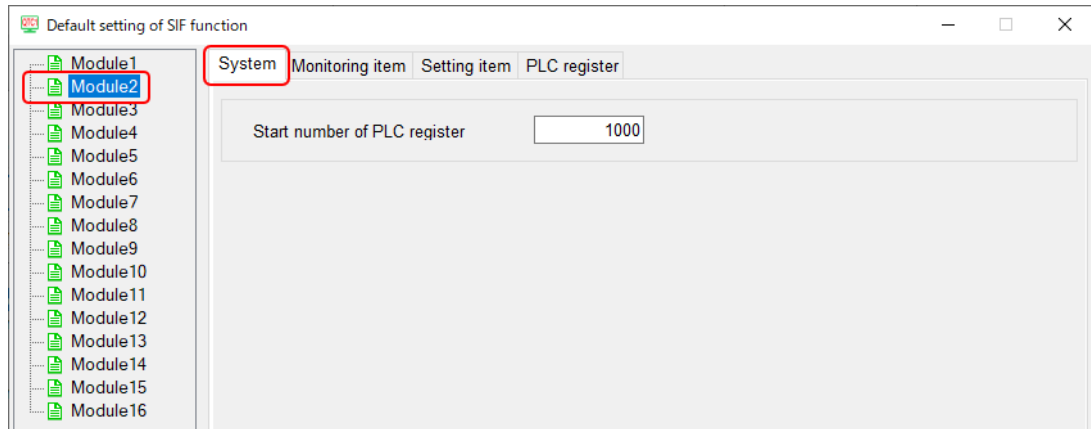

(Fig. 13.6.3-4)

(2) PLC register start number, (5) Monitor item 1 to 3 and (6) Setting item 1 to 7 are selected, and (7) Control module power is turned OFF → ON.

13.7 Operation

The following explains how to connect two control modules to the PLC.

Example of connection between PLC and QTC1-4P, QTC1-40

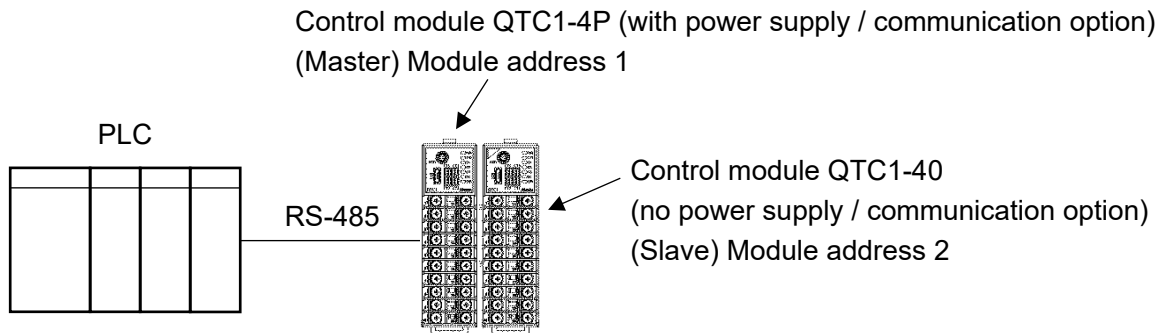

(Fig. 13.7-1)

13.7.1 Communication Procedure

- (1) The control module QTC1-4P becomes the master and collects the valid monitor items and setting items of the control module QTC1-40 (slave).
- (2) After the PLC communication start waiting time has elapsed, the control module QTC1-4P periodically writes the item selected in the monitor items to the PLC register.

Also, the item selected from the setting items is read from the PLC register in response to a setting request.

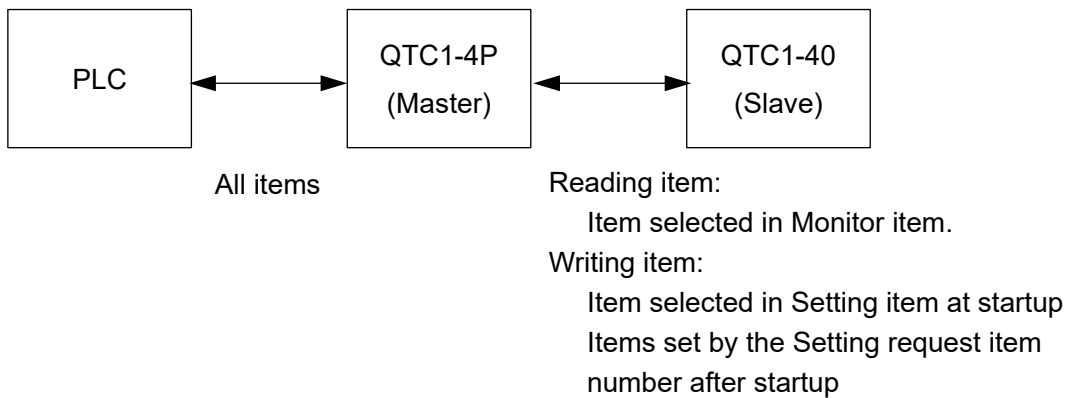

(Fig. 13.7.1-1)

13.7.2 Handshake between Control Module QTC1-4P and PLC

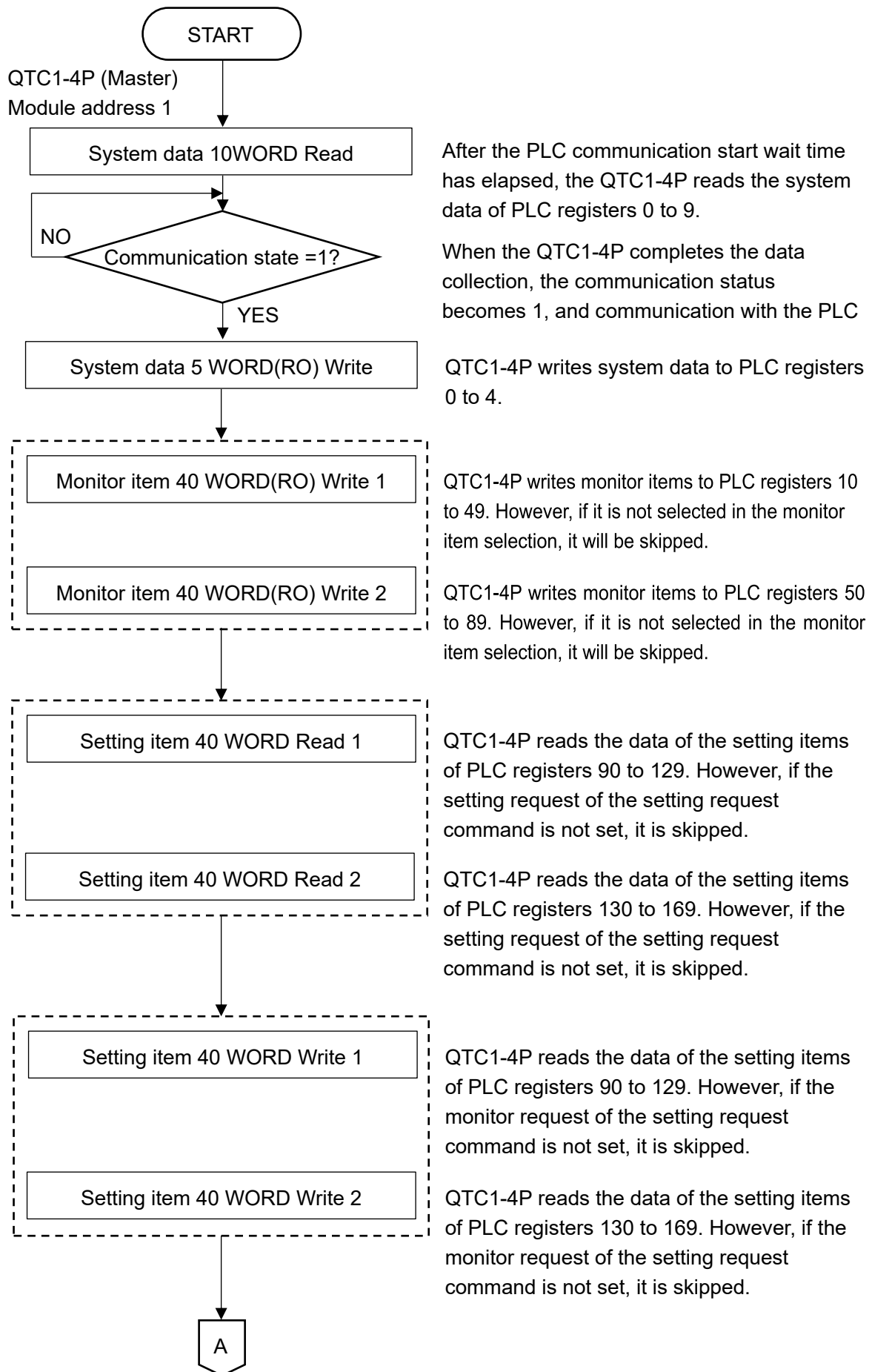

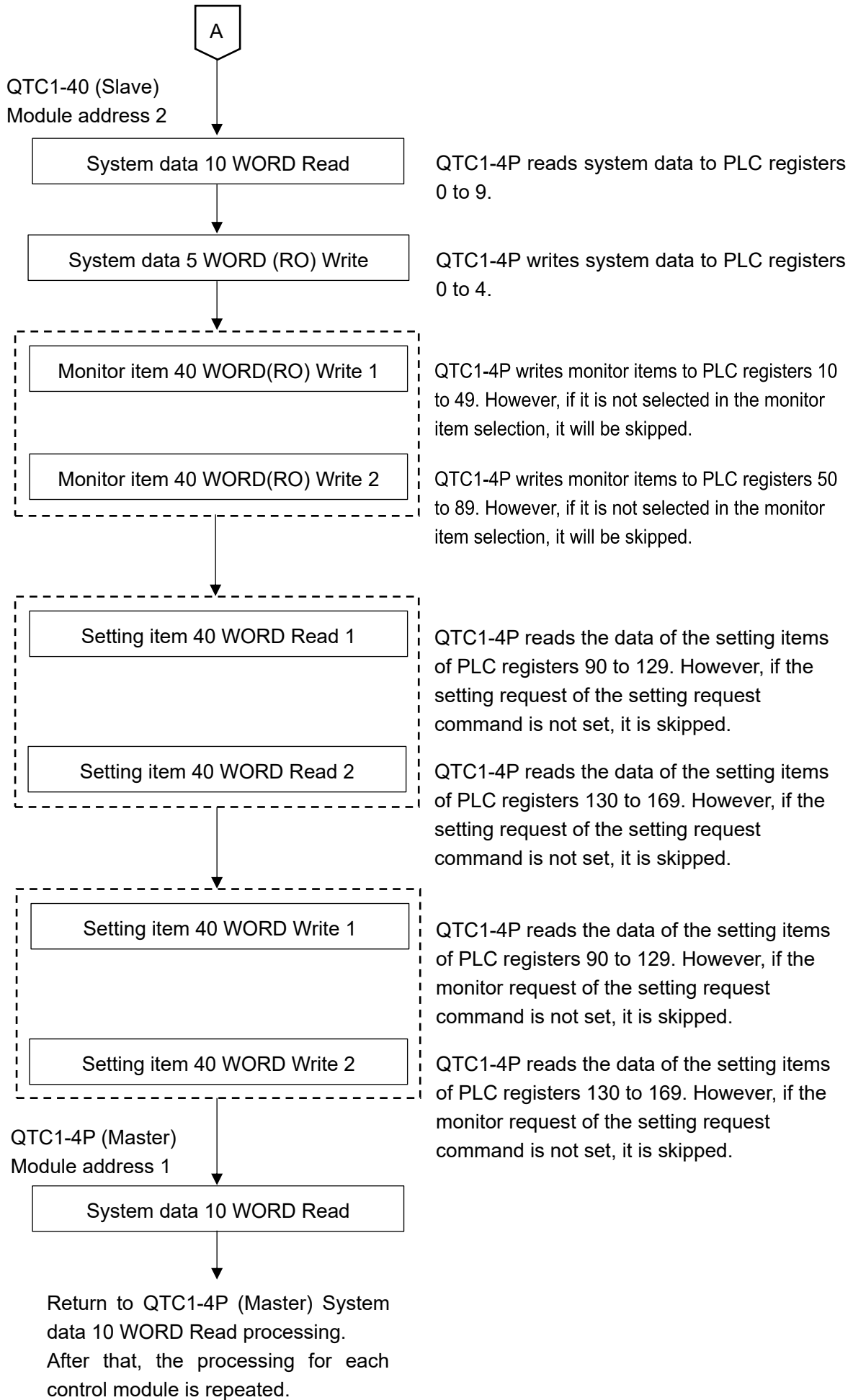

13.7.3 PLC Communication Data Map

Shown below is the PLC communication data map when the initial setting example for PLC communication is set.

Example of initial setting for PLC communication

MODBUS address		Name	QTC1-4P (Master) setting	QTC1-40 (Slave) setting
HEX	DEC			
0384	900	PLC register start number	1000	1100
0385	901	PLC response wait time	250	250
0386	902	PLC communication start wait time	5	5
0387	903	Reservation (Not used)	0	0
0388	904	Reservation (Not used)	0	0
0389	905	Monitor item 1	31	31
038A	906	Monitor item 2	0	0
038B	907	Monitor item 3	0	0
038C	908	Reservation (Not used)	0	0
038D	909	Reservation (Not used)	0	0
038E	910	Setting item 1	57827	57827
038F	911	Setting item 2	2721	2721
0390	912	Setting item 3	0	0
0391	913	Setting item 4	0	0
0392	914	Setting item 5	0	0
0393	915	Setting item 6	0	0
0394	916	Setting item 7	0	0

PLC data register layout

	QTC1-4P (Master)	QTC1-40 (Slave)
Information between QTC1-4 and PLC (system data)	1000 to 1009	1100 to 1109
Monitor item	1010 to 1029	1110 to 1129
Setting item	1030 to 1085	1130 to 1185

Details of information (system data) between control module QTC1-4 and PLC

Control module QTC1-4 (Master)

Data	PLC data register	Attribute	Description
Communication status	1000	RO	0: QTC1-4P collecting data 1: QTC1-4P completes data collection (Startup: Initial setting value of each slave)
QTC1-4 - PLC Normal communication monitor	1001	RO	Increment counter (*1) Repeat 0 to 65535 → 0 to 65535
QTC1-4 Error code	1002	RO	B0: PLC register R/W error 0: Normal 1: Error B1: QTC1-4P communication error 0: Normal 1: Error B2: QTC1-4P Negative acknowledgement when setting0: 0: Normal 1: Error (It will be cleared when B0 of 1006 is cleared.)
Setting request monitor	1003	RO	B0: Setting (Reflect and set to B0 of 1006.) B1: Monitoring (Reflect and set until B1 of 1006 is cleared.)
Reservation	1004	RO	
Setting request item number	1005	R/W	0: All items selected in setting items 1 to 7 1 to 112: Items selected in setting items 1 to 7 (1 data) Only the data (1 data) of the selected item will be read or written. However, because communication with the PLC is a batch process, all the selected items are read or written.
Setting request command (*2)	1006	R/W	B0: Setting request (PLC → QTC1-4P) QTC1-4P requests to read the setting item data from the PLC register. B1: Monitor request (QTC1-4P → PLC) QTC1-4P requests to write the setting item data to the PLC register. After the setting request or monitor request is completed, QTC1-4P clears each bit.
Reservation	1007	R/W	
Reservation	1008	R/W	
Reservation	1009	R/W	

(*1): The increment counter is +1 when QTC1-4P sends out a command.

The number of increments of the count value varies depending on the number of valid monitor items and setting items, the number of connected units, and whether or not a setting request is received.

(e.g.) If the initial value of the number of valid monitor items is 31 and only one monitor is connected, the count value is +3, and if two monitor items are connected, the count value is +6.

(*2): If the setting request and the monitor request are set at the same time, processing is performed in the following procedure: ① setting request (QTC1-4P reads PLC register data), ② monitor request (writing data to PLC register).

If the setting request is set during the monitor request, the monitor request is discarded and the monitoring request is made again after the setting request.

Control module QTC1-40 (Slave)

Data	PLC data register	Attribute	Description
Communication status	1100	RO	0: QTC1-4P collecting data of QTC1-40 1: QTC1-4P completes data collection of QTC1-40 (Startup: Initial setting value of each slave)
QTC1-4 - PLC Normal communication monitor	1101	RO	Increment counter (*1) Repeat 0 to 65535 → 0 to 65535
QTC1-4 Error code	1102	RO	B0: PLC register R/W error 0: Normal 1: Error B1: Communication error between QTC1-4P and QTC1-40 0: Normal 1: Error B2: Negative acknowledgement when setting QTC1-4P to QTC1-40 (It will be cleared when B0 of 1006 is cleared.) 0: Normal 1: Error
Setting request monitor	1103	RO	B0: Setting (Reflect and set to B0 of 1006.) B1: Monitoring (Reflect and set until B1 of 1006 is cleared.)
Reservation	1104	RO	
Setting request item number	1105	R/W	0: All items selected in setting items 1 to 7 1 to 112: Items selected in setting items 1 to 7 (1 data) Only the data (1 data) of the selected item will be read or written. However, because communication with the PLC is a batch process, all the selected items are read or written.
Setting request command (*2)	1106	R/W	B0: Setting request (PLC → QTC1-4P) QTC1-4P requests to read the setting item data from the PLC register. B1: Monitor request (QTC1-4P → PLC) QTC1-4P requests to write the setting item data to the PLC register. After the setting request or monitor request is completed, QTC1-4P clears each bit.
Reservation	1107	R/W	
Reservation	1108	R/W	
Reservation	1109	R/W	

(*1): The increment counter is +1 when QTC1-4P sends out a command.

The number of increments of the count value varies depending on the number of valid monitor items and setting items, the number of connected units, and whether or not a setting request is received.

(e.g.) If the initial value of the number of valid monitor items is 31 and only one monitor is connected, the count value is +3, and if two monitor items are connected, the count value is +6.

(*2): If the setting request and the monitor request are set at the same time, processing is performed in the following procedure: ① setting request (QTC1-4P reads PLC register data), ② monitor request (writing data to PLC register).

If the setting request is set during the monitor request, the monitor request is discarded and the monitoring request is made again after the setting request.

Details of monitor item and setting item between control module QTC1-4 and PLC

Control module QTC1-4P (Master)

Data item	Channel	PLC data register	Attribute	Data
PV reading (Including difference)	CH1	1010	RO	The value of "15.2.1 Control range (P.15-6)". Supports input math function (difference input, addition input) and input difference detection function.
	CH2	1011		
	CH3	1012		
	CH4	1013		
MV reading	CH1	1014	RO	Output low limit to Output high limit
	CH2	1015		
	CH3	1016		
	CH4	1017		
SV reading	CH1	1018	RO	Scaling low limit to Scaling high limit
	CH2	1019		
	CH3	1020		
	CH4	1021		
Status flag 1 reading	CH1	1022	RO	B0: Control Allowed/Prohibited 0: Prohibited 1: Allowed B1: AT Perform/Cancel 0: Cancel 1: Perform B2: Auto/Manual control 0: Automatic 1: Manual B3: Control output 0: OFF 1: ON B4: Input error (Overscale) 0: Normal 1: Error B5: Input error (Underscale) 0: Normal 1: Error B6: Alarm 1 output 0: OFF 1: ON B7: Alarm 2 output 0: OFF 1: ON B8: Alarm 3 output 0: OFF 1: ON B9: Alarm 4 output 0: OFF 1: ON B10: Loop brake alarm output 0: OFF 1: ON B11: Heater burnout alarm output 0: OFF 1: ON B12: Input difference 0: Within range 1: Out of range B13: Not used (indefinite) B14: Power supply identification 0: 24 V DC 1: USB bus power B15: Non-volatile IC memory error 0: Normal 1: Error
	CH2	1023		
	CH3	1024		
	CH4	1025		

Data item	Channel	PLC data register	Attribute	Data
Status flag 2 reading	CH1 CH2 CH3 CH4	1026 1027 1028 1029	RO	B0: Auto balance control 0: None 1: During auto balance control B1 to B3: Not used (indefinite) B4: Cold junction error 0: Normal 1: Error B5: Sensor error 0: Normal 1: Error B6: ADC error 0: Normal 1: Error B7: Host setting value change flag 0: Without flag 1: With flag B8: USB setting value change flag 0: Without flag 1: With flag B9 to B15: Not used (indefinite)
Control Allowed/Prohibited selection	CH1 CH2 CH3 CH4	1030 1031 1032 1033	R/W	0: Prohibited 1: Allowed
AT Perform/Cancel selection	CH1 CH2 CH3 CH4	1034 1035 1036 1037	R/W	0: AT Cancel 1: AT Perform
SV setting	CH1 CH2 CH3 CH4	1038 1039 1040 1041	R/W	Scaling low limit to Scaling high limit
Proportional band setting	CH1 CH2 CH3 CH4	1042 1043 1044 1045	R/W	1 to Input span °C (°F) or 0.1 to Input span °C (°F) when direct current and DC voltage input 0.10 to 100.00% or 0.1 to 1000.0%
Integration time setting	CH1 CH2 CH3 CH4	1046 1047 1048 1049	R/W	0 to 3600 seconds or 0.0 to 2000.0 seconds when "2: Slow-PID control" is selected in control action selection. 1 to 3600 seconds or 0.1 to 2000.0 seconds
Derivative time setting	CH1 CH2 CH3 CH4	1050 1051 1052 1053	R/W	0 to 3600 seconds or 0.0 to 2000.0 seconds

Data item	Channel	PLC data register	Attribute	Data
Alarm 1 action selection	CH1	1054	R/W	0: No action 1: High limit alarm 2: Lowh limit alarm 3: High/Low limits alarm 4: High/Low limit s range 5: Process High alarm 6: Process low alarm 7: High limit with standby 8: Low limit with standby 9: High/Low limits alarm with individually 10: High/Low limits alarm individually 11: High/Low limit s range alarm individually 12: High/Low limits alarm with standby individually Refer to "Alarm 1 to 4 value setting range table".
	CH2	1055		
	CH3	1056		
	CH4	1057		
Alarm 2 action selection	CH1	1058	R/W	
	CH2	1059		
	CH3	1060		
	CH4	1061		
Alarm 3 action selection	CH1	1062	R/W	
	CH2	1063		
	CH3	1064		
	CH4	1065		
Alarm 4 action selection	CH1	1066	R/W	
	CH2	1067		
	CH3	1068		
	CH4	1069		
Alarm 1 value setting	CH1	1070	R/W	
	CH2	1071		
	CH3	1072		
	CH4	1073		
Alarm 2 value setting	CH1	1074	R/W	
	CH2	1075		
	CH3	1076		
	CH4	1077		
Alarm 3 value setting	CH1	1078	R/W	
	CH2	1079		
	CH3	1080		
	CH4	1081		
Alarm 4 value setting	CH1	1082	R/W	
	CH2	1083		
	CH3	1084		
	CH4	1085		

Alarm 1 to 4 value setting range table

Alarm type	Setting range
No action	
High limit alarm	-(Input span) to Input span (*1)
Lowh limit alarm	-(Input span) to Input span (*1)
High/Low limits alarm	0 to Input span (*1)
High/Low limit s range	0 to Input span (*1)
Process High alarm	Input range lower limit to Input range high limit (*2)
Process low alarm	Input range lower limit to Input range high limit (*2)
High limit with standby	-(Input span) to Input span (*1)
Low limit with standby	-(Input span) to Input span (*1)
High/Low limits alarm with	0 to Input span (*1)
High/Low limits alarm individually	0 to Input span (*1)
High/Low limit s range alarm individually	0 to Input span (*1)
High/Low limits alarm with standby individually	0 to Input span (*1)

(*1): When direct current input and DC voltage input, the input span is the scaling width.

(*2): When direct current input and DC voltage input, the Input range lower limit is the scaling lower limit, and the Input range high limit is the scaling high limit.

Control module QTC1-40 (Slave)

Data item	Channel	PLC data register	Attribute	Data
PV reading (Including difference)	CH1	1110	RO	Same as QTC1-4P (Master).
	CH2	1111		
	CH3	1112		
	CH4	1113		
MV reading	CH1	1114	RO	Same as QTC1-4P (Master).
	CH2	1115		
	CH3	1116		
	CH4	1117		
SV reading	CH1	1118	RO	Same as QTC1-4P (Master).
	CH2	1119		
	CH3	1120		
	CH4	1121		
Status flag 1 reading	CH1	1122	RO	Same as QTC1-4P (Master).
	CH2	1123		
	CH3	1124		
	CH4	1125		
Status flag 2 reading	CH1	1126	RO	Same as QTC1-4P (Master).
	CH2	1127		
	CH3	1128		
	CH4	1129		
Control Allowed/Prohibited selection	CH1	1130	R/W	Same as QTC1-4P (Master).
	CH2	1131		
	CH3	1132		
	CH4	1133		
AT Perform/Cancel selection	CH1	1134	R/W	Same as QTC1-4P (Master).
	CH2	1135		
	CH3	1136		
	CH4	1137		
SV setting	CH1	1138	R/W	Same as QTC1-4P (Master).
	CH2	1139		
	CH3	1140		
	CH4	1141		
Proportional band setting	CH1	1142	R/W	Same as QTC1-4P (Master).
	CH2	1143		
	CH3	1144		
	CH4	1145		
Integration time setting	CH1	1146	R/W	Same as QTC1-4P (Master).
	CH2	1147		
	CH3	1148		
	CH4	1149		
Derivative time setting	CH1	1150	R/W	Same as QTC1-4P (Master).
	CH2	1151		
	CH3	1152		
	CH4	1153		

Data item	Channel	PLC data register	Attribute	Data
Alarm 1 action selection	CH1	1154	R/W	Same as QTC1-4P (Master).
	CH2	1155		
	CH3	1156		
	CH4	1157		
Alarm 2 action selection	CH1	1158	R/W	
	CH2	1159		
	CH3	1160		
	CH4	1161		
Alarm 3 action selection	CH1	1162	R/W	
	CH2	1163		
	CH3	1164		
	CH4	1165		
Alarm 4 action selection	CH1	1166	R/W	
	CH2	1167		
	CH3	1168		
	CH4	1169		
Alarm 1 value setting	CH1	1170	R/W	
	CH2	1171		
	CH3	1172		
	CH4	1173		
Alarm 2 value setting	CH1	1174	R/W	
	CH2	1175		
	CH3	1176		
	CH4	1177		
Alarm 3 value setting	CH1	1178	R/W	
	CH2	1179		
	CH3	1180		
	CH4	1181		
Alarm 4 value setting	CH1	1182	R/W	
	CH2	1183		
	CH3	1184		
	CH4	1185		

13.7.4 Data Exchange between Control Module QTC1-4 and P-PLC

Data transfer between the control module QTC1-4P and PLC is performed by the setting request item number and setting request command.

(1) Setting request item number

Set whether to transfer the data of all items selected in setting item 1 to 7 selection or only the data (1 data) of the selected item.

0: Transfers the data of all items selected in setting item 1 to 7 selection.

1 to 112: Transfers only the data (1 data) of the item selected in setting item 1 to 7 selection.

(2) Setting request command

The setting request command includes setting request and monitor request.

B0: Setting request (PLC → QTC1-4P)

The control module QTC1-4P is a command to request to read the data of the setting item of the PLC register.

B1: Monitor request (QTC1-4P → PLC)

The control module QTC1-4P is a command to request to write the data of the setting item of the PLC register.

If setting request and monitor request are set at the same time, processing is performed in the order of setting request (QTC1-4P reads the data of the setting item in the PLC register) and then monitor request (writing the data of the setting item in the PLC register).

If a setting request is set during monitor request, the monitor request is discarded and the monitor request is made again after the setting request.



Caution

When setting data, first write all the setting item data to the PLC register.

Note that if you change the setting items of the control module QTC1-4P without writing all the setting item data, it may be overwritten with an undefined value and malfunction may occur.

Data setting procedure

When select the control allowed in control allowed/prohibited selection of the control module QTC1-4P

- (1) Set 0 to the setting request item number
To write all the setting item data to the PLC register, set 0 to 1005 (setting request item number).
- (2) Set B1 (monitor request) of the setting request command
Set 1 (decimal number: 2) to B1 (monitor request) of 1006 (setting request command).
The control module QTC1-4P starts writing the setting item data to the PLC register.
- (3) Check B1 (monitor request) of the setting request command
When the writing of the setting item data to the PLC register is completed, B1 (monitor request) of 1006 (setting request command) is cleared.
- (4) Set data
Set 1 (control allowed) to 1030 to 1033 (control allowed/prohibited selection) of the PLC register.
- (5) Set 1 to the setting request item number
To read the control allowed/prohibited selection data of the PLC register, set 1 to 1005 (setting request item number).
- (6) Set B0 (setting request) of the setting request command
Set 0 (decimal number: 1) to B0 (monitor request) of 1006 (setting request command).
The control module QTC1-4P starts reading the setting item data of the PLC register.
- (7) Check B0 (monitor request) of the setting request command
When the reading of the setting item data to the PLC register is completed, B0 (monitor request) of 1006 (setting request command) is cleared.

Example of PV read and SV write operations

Explanation: This is an example of reading and writing the PV and SV of the QTC1-4P and QTC1-40. The PLC registers are assigned to 1000: QTC1-4P and 1100: QTC1-40.

1. Data flow and flag operation to match the PLC register and QTC1 settings at power-on

- ① Write 0 to 1005. (Select all setting items set by the SIF function [only SV in this case])
- ② Write 2 to 1006. (Specify data transfer from QTC1-4P to PLC)
- ③ Write SV of QTC1-4P to 1014 to 1017.
- ④ QTC1-4P reads the SV of QTC1-40 and writes it to 1104 to 1107.
- ⑤ QTC1-4P writes 0 to 1006.

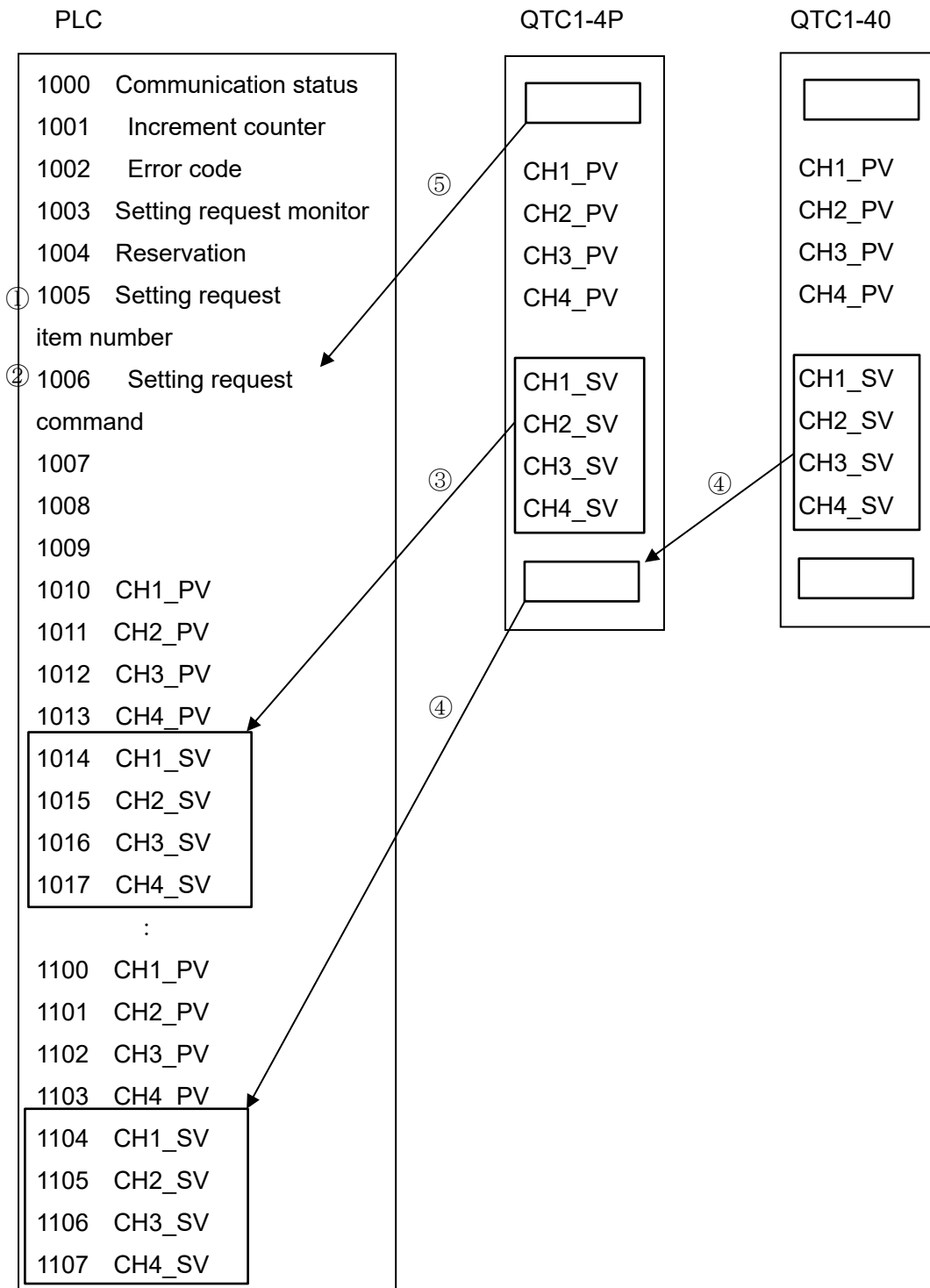

2. Data flow and flag operations when PV read

- ①,④ QTC1-4P reads the system data in PLC registers 0 to 9.
- ②,⑤ QTC1-4P writes system data to PLC registers 0 to 4.
- ③ QTC1-4P writes PV to PLC registers 1010 to 1013.
- ⑥ QTC1-4P reads the PV from QTC1-40 and writes the PV to PLC registers 1100 to 1103.

*Only the SIF function is set by the console software; no flag operation is required.

The PV of each register is constantly updated at the timings ① to ⑥ above.

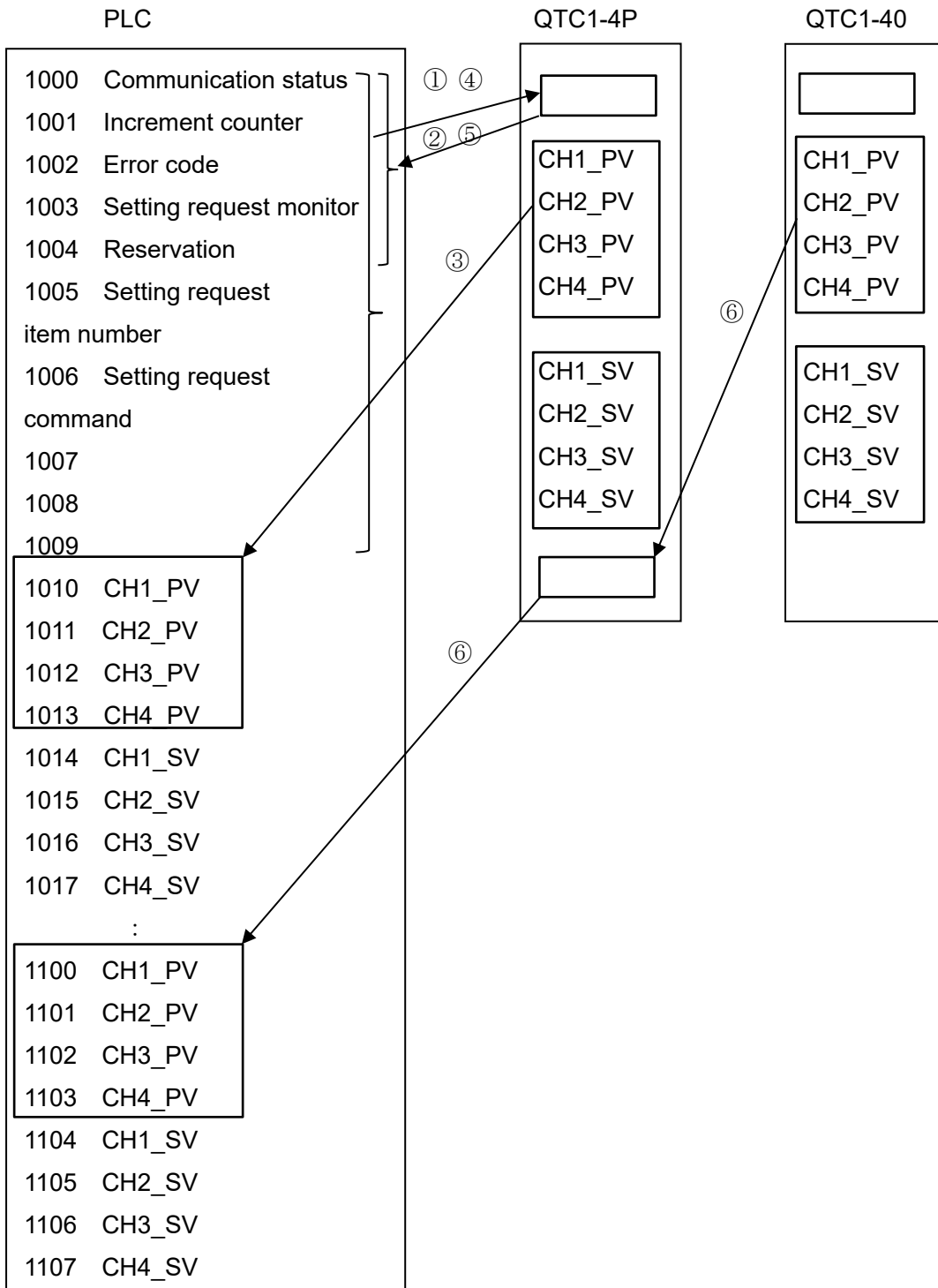

3. Data flow and flag operations when SV write

- ① 1014 to 1017 (SV of QTC1-4P) is changed.
- ② Change 1104 to 1107 (SV of QTC1-40).
- ③ Write 0 or 6 to 1005.
0: Select all setting items set by the SIF function (only SV in this case)
6: SV only (see P13-20)
- ④ Write 1 to 1006. (Specify data transfer from PLC to QTC1-4P)
- ⑤ QTC1-4P writes data from 1014 to 1017 to SV of QTC1-4P.
- ⑥ QTC1-4P writes data from 1104 to 1107 to the SV of QTC1-40.
- ⑦ QTC1-4P writes 0 to 1006.

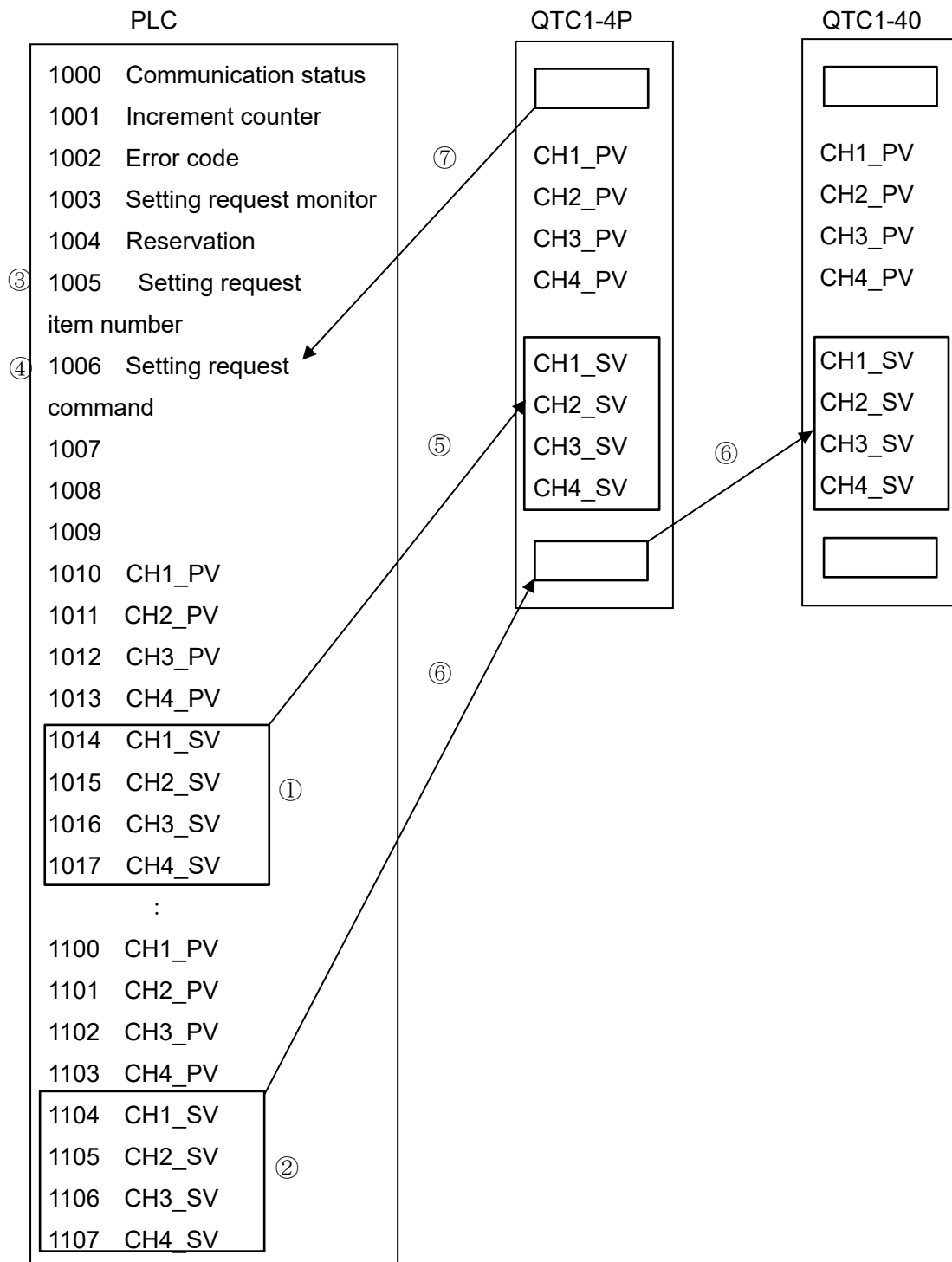

14 CUnet Communication

CUnet communication writes the reading value from the module to the global memory (GM) specified by the station address (SA).

It reads the setting values from the master address (DOSA) and sets them to the module.

The setting value can also be changed by using the mail function of CUnet.

Configuration example of host computer (master board) and QTC1-4C

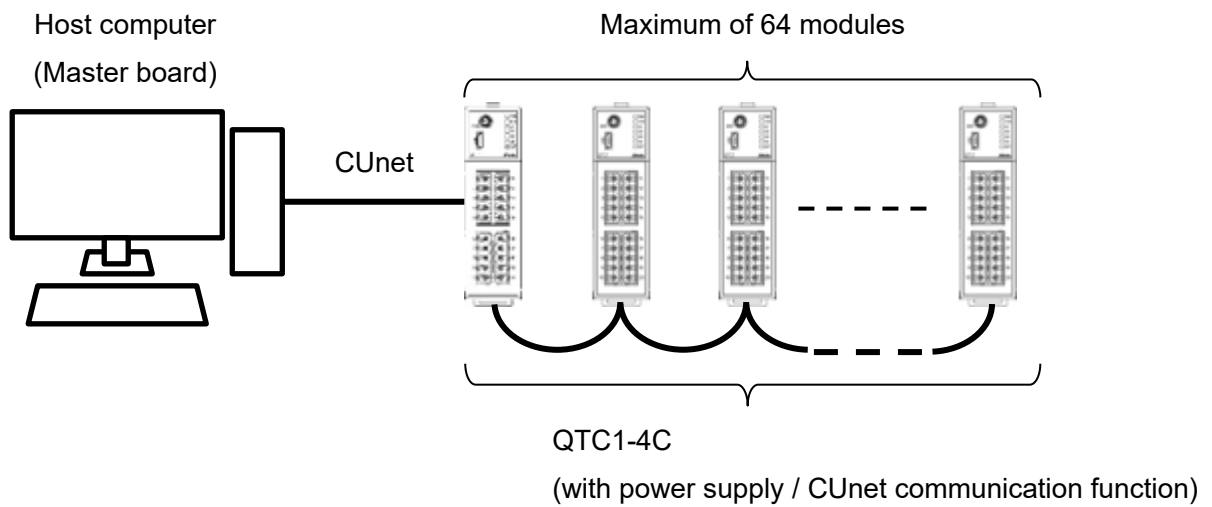

(Fig. 14-1)

14.1 Flow of Before Operation

The flow of operation when using CUNet communication is shown below.

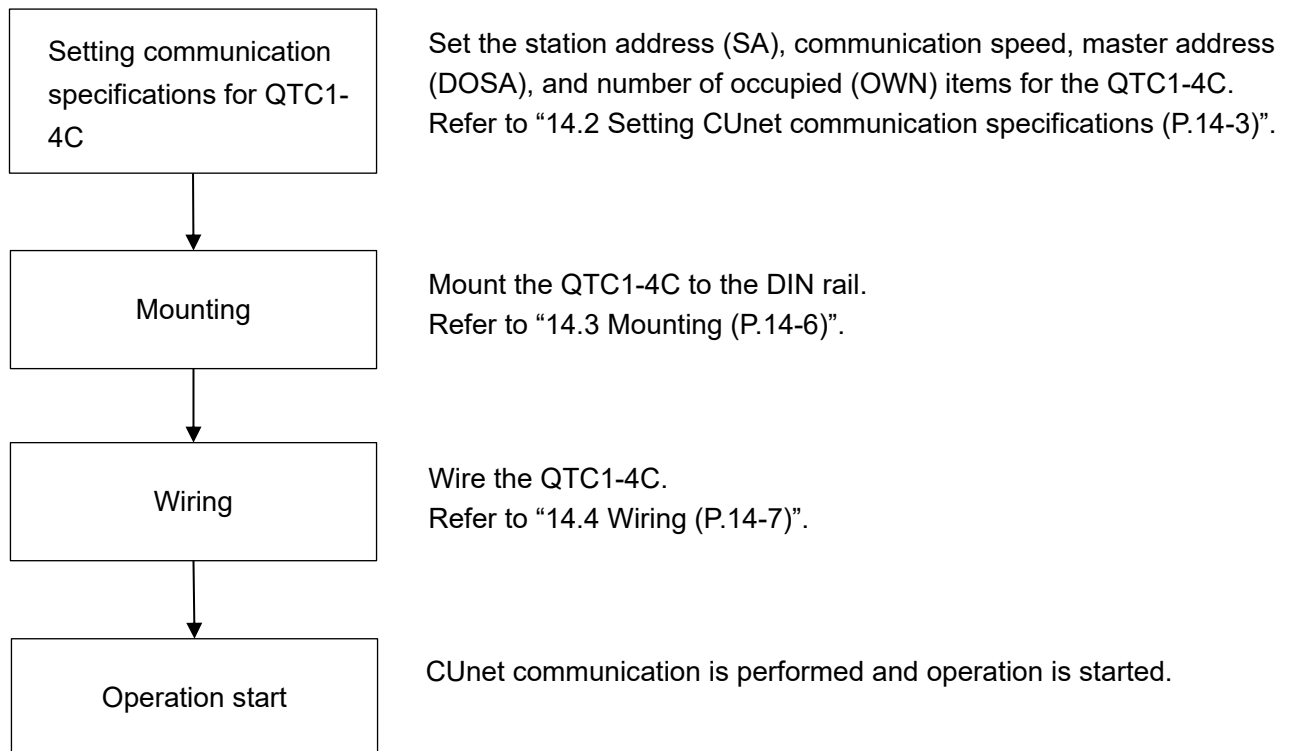

(Fig. 14.1-1)

14.2 Setting CUnet communication specifications

The CUnet communication specifications are set by the dip switches (SW10, SW11) on the base part.

(1) Case removal

- ① Push the release lever on the top of this instrument to unlock it.
- ② Remove the case.

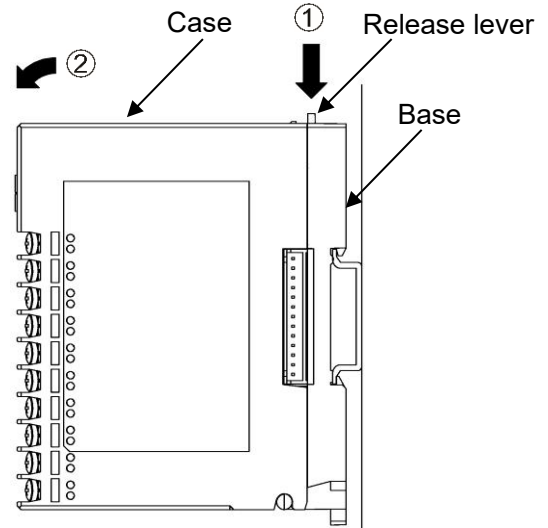

(Fig. 14.2-1)

(2) Station address (SA), communication speed setting (SW10)



Caution

Please set the station address (SA) so that there are no duplicate addresses.

The station address (SA) and communication speed are set by DIP switch (SW10).

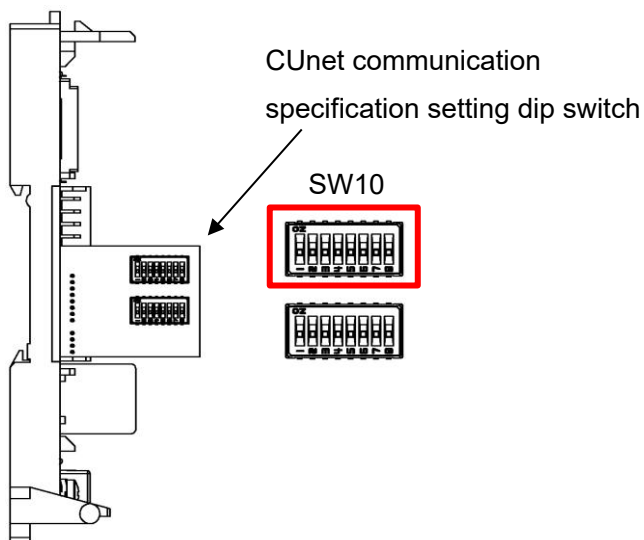

(Fig. 14.2-2)

Set the station address (SA) and communication speed.

The setting range of the station address (SA) is 00 to 63.

No.	Setting item	Status	Factory default
1	Station address setting	Bit0 ON: Enable, OFF: Disable	Disable
2		Bit1 ON: Enable, OFF: Disable	Disable
3		Bit2 ON: Enable, OFF: Disable	Disable
4		Bit3 ON: Enable, OFF: Disable	Disable
5		Bit4 ON: Enable, OFF: Disable	Disable
6		Bit5 ON: Enable, OFF: Disable	Disable
7	Communication speed setting	7: OFF 8: OFF 12 Mbps	12 Mbps
8		7: ON 8: OFF 6 Mbps	
		7: OFF 8: ON 3 Mbps	
		7: ON 8: ON Disable (12 Mbps)	

(3) Master address (DOSA) and number of occupied (OWN) items selection (SW11)

The master address (DOSA) and the number of occupied (OWN) items are set by DIP switch (SW11).

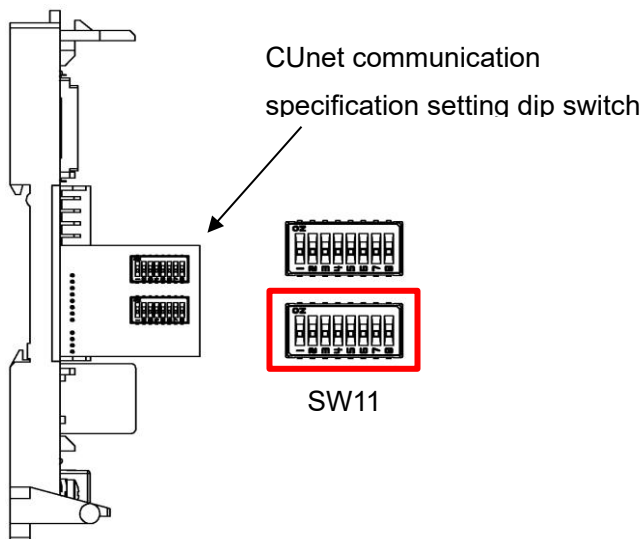

(Fig. 14.2-3)

Set the master address (DOSA) and the number of occupied (OWN) items.

Set which master global memory (GM) area data is output to the analog output terminal.

The setting range of the master address (DOSA) is 00 to 63.

No.	Setting item	Status	Factory default
1	Master address setting	Bit0 ON: Enable, OFF: Disable	Disable
2		Bit1 ON: Enable, OFF: Disable	Disable
3		Bit2 ON: Enable, OFF: Disable	Disable
4		Bit3 ON: Enable, OFF: Disable	Disable
5		Bit4 ON: Enable, OFF: Disable	Disable
6		Bit5 ON: Enable, OFF: Disable	Disable
7	Number of occupied (OWN) items selection(*)	7: OFF 8: OFF 1 item	1 item
8		7: ON 8: OFF 2 items	
		7: OFF 8: ON 3 items	
		7: ON 8: ON 4 items	

(*): The following items are allocated to global memory for each module.

Number of occupied (OWN) items	QDM1	
	DI item	DO item
1	PV: 03E8-03EB	Output: 0014-0017
2	Status 1: 03F4-03F7	
3	MV: 03EC-03EF	
4		

Shaded area is invalid because there is no allocation (no area is allocated in global memory)

(4) Case mounting

- ① Hook the case on the lower part ① of this instrument.
- ② Mount the case so that the lower part ① of this instrument is the fulcrum and covers the release lever. There is a clicking sound.

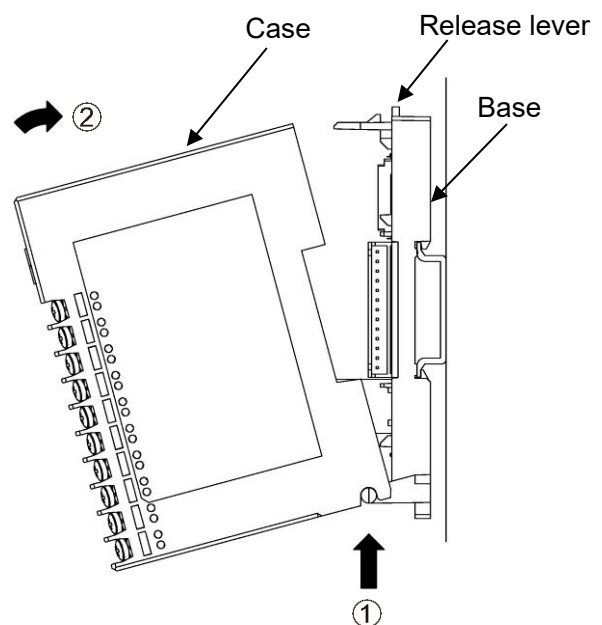

(Fig. 14.2-4)

14.3 Mounting

Mounting to the DIN rail

- ① Lower the lock lever of this instrument. (The lock lever of this instrument has a spring structure, but if lower it in the direction of the arrow until it stops, it will be locked in that position.)
- ② Hook the part ② of this instrument onto the top of the DIN rail.
- ③ Insert the lower part of this instrument with the part ② as a fulcrum.
- ④ Raise the lock lever of this instrument.

Make sure it is fixed to the DIN rail.

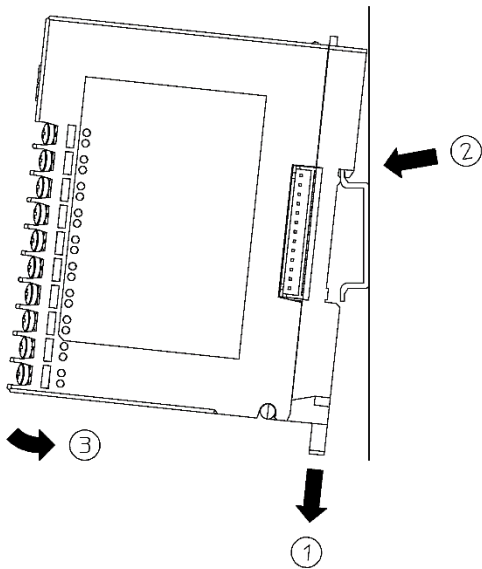

(Fig. 14.3-1)

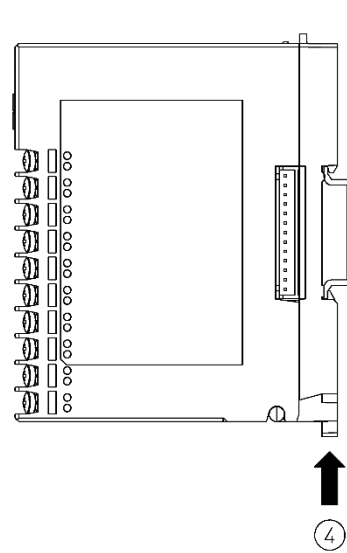

(Fig. 14.3-2)

Removal from the DIN rail

- ① Insert a flat blade screwdriver into the lock lever of this instrument and lower the lock lever until it stops.
- ② Remove this instrument from the DIN rail by lifting it from below.

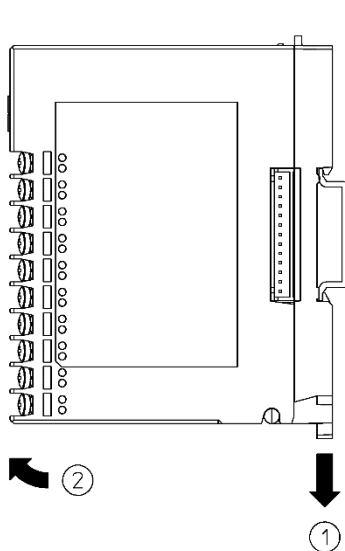

(Fig. 14.3-3)

14.4 Wiring

14.4.1 Wiring for Power Supply and Communication

The terminal block for power supply and communication is located on the base of this instrument. Wiring by the following procedure.

(1) Case removal

- ① Push the release lever on the top of this instrument to unlock it.
- ② Remove the case.

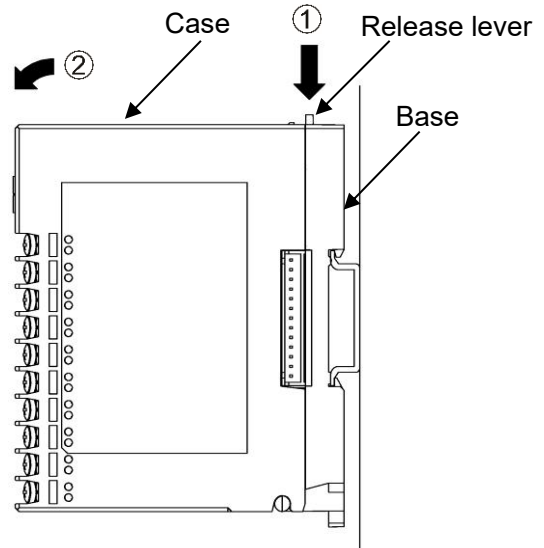

(Fig. 14.4.1-1)

(2) Wiring

CUnet communication

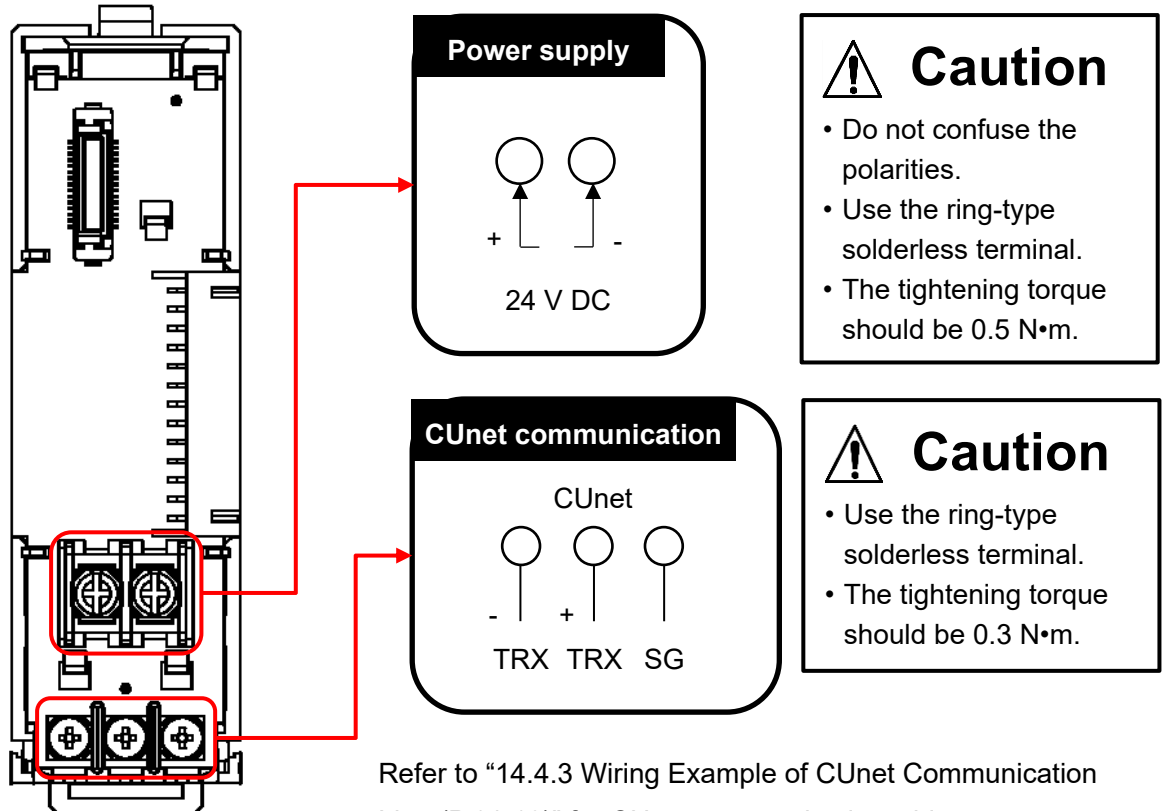

(Fig. 14.4.1-2)

(3) Case mounting

- ① Hook the case on the lower part ① of this instrument.
- ② Mount the case so that the lower part ① of this instrument is the fulcrum and covers the release lever. There is a clicking sound.

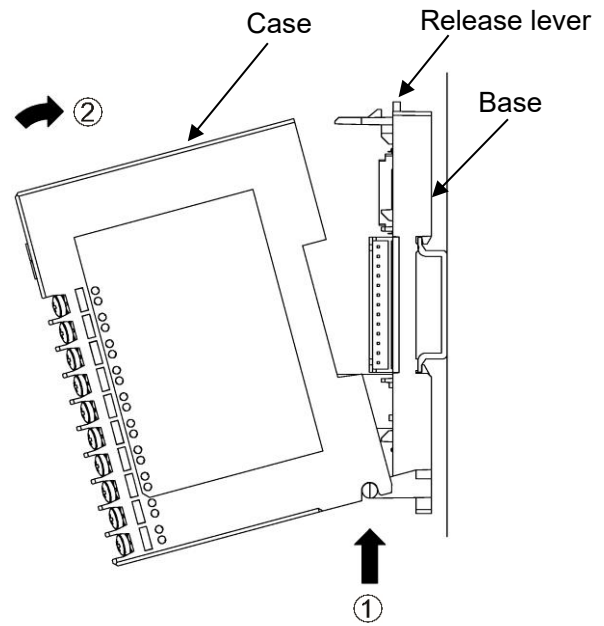

(Fig. 14.4.1-3)

14.4.2 Wiring for Input, Output and CT

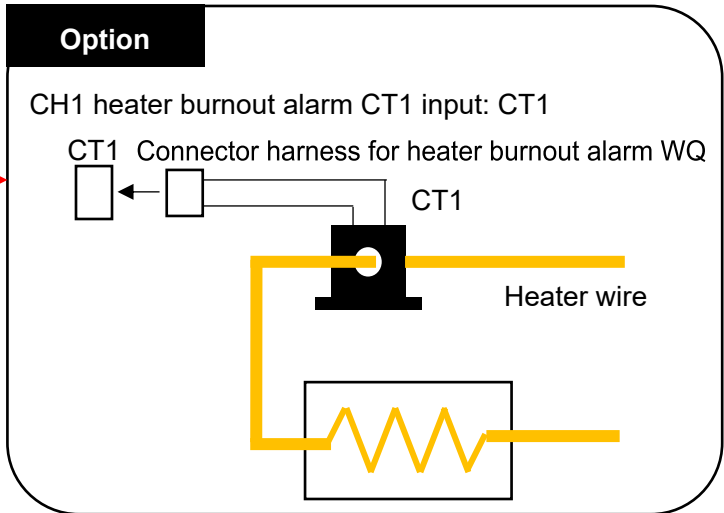
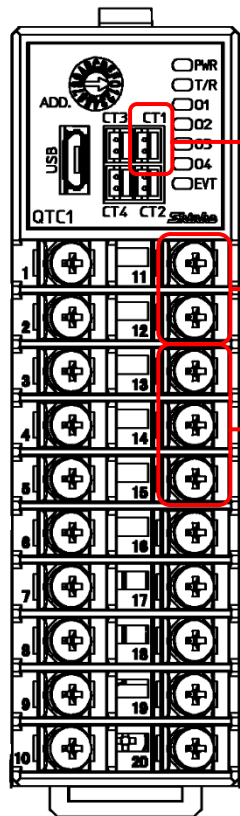

CH2 heater burnout alarm CT1 input: CT2
 CH3 heater burnout alarm CT1 input: CT3
 CH4 heater burnout alarm CT1 input: CT4

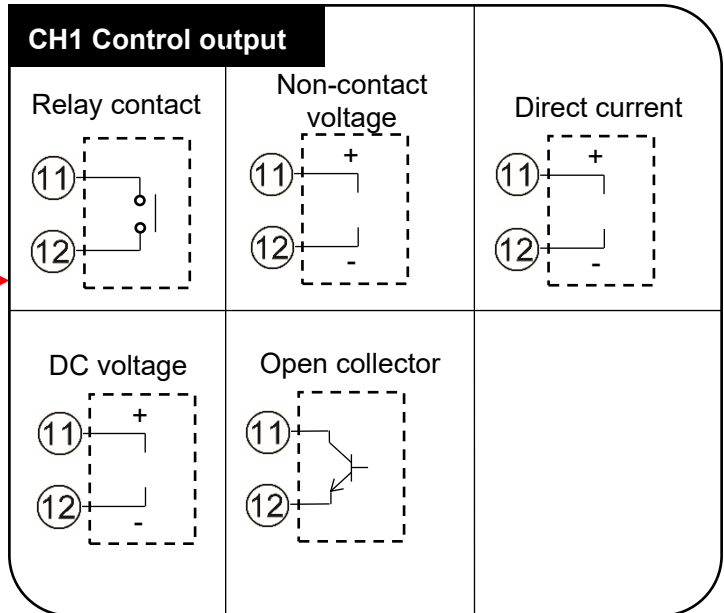

CH2 Control output: ⑩ ⑨
 CH3 Control output: ⑤ ④
 CH4 Control output: ⑩ ⑨

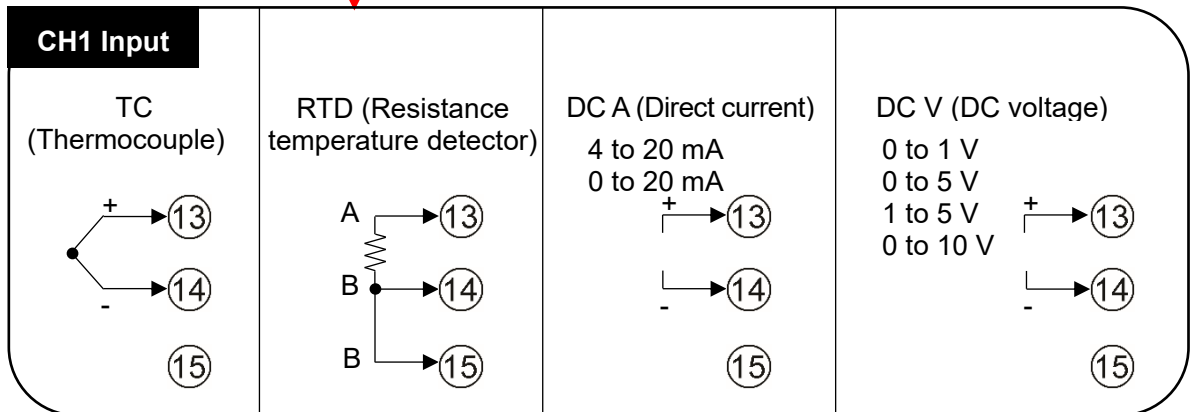

CH2 Input: ⑱ ⑲ ⑳
 CH3 Input: ③ ② ①
 CH4 Input: ⑧ ⑦ ⑥

(Fig. 14.4.2-1)

14.4.3 Wiring Example of CUnet Communication Line

Connect the LAN cable between the upper system (master) and this instrument.

Recommended cable: LAN cable (straight cable) / Category 5 or higher shielded cable

Install a 100 Ω terminator [RES-S07-100 (optional)] on the last unit in the communication line.

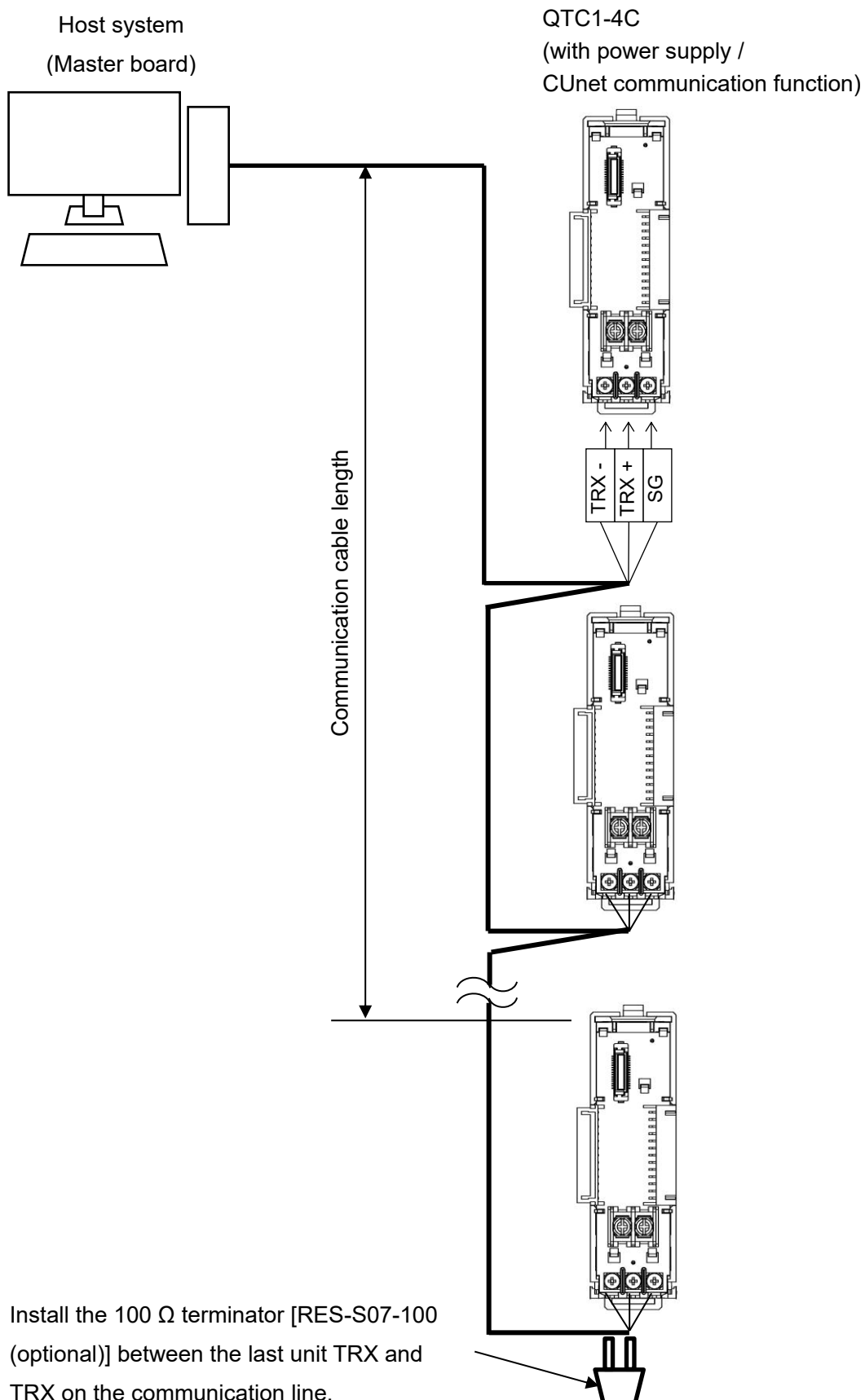

(Fig. 14.4.3-1)

The communication cable length is the total length of the communication cable from the upper system (master) to the last unit, and varies depending on the communication speed.

The communication cable length can be extended by inserting a dedicated HUB for CUnet.

Communication speed	Communication cable length		
	No HUB	HUB 1-deck	HUB 2-deck
12 Mbps	100 m	200 m	300 m
6 Mbps	200 m	400 m	600 m
3 Mbps	300 m	600 m	900 m

14.5 Global Memory (GM)

The memory space where memory data is shared is called global memory (GM).

The size of global memory (GM) is 512 bytes and is divided into 64 areas in 8-byte units corresponding to station addresses (SA).

The addresses in global memory (GM) correspond to station addresses (SA).

Station addresses (SA)	Global memory (GM)
00(0x00)	000H to 007H
01(0x01)	008H to 00FH
02(0x02)	010H to 017H
...	...
63(0x3F)	1F8H to 1FFH

The basic unit of the amount of data that can be written to global memory (GM) by one station is 8 bytes.

- Station 00 (0x00) writes data in the 000H to 007H area of the global memory (GM).
- Station 63 (0x3F) writes data in the 1F8H to 1FFH area of the global memory (GM).

All stations can read all areas of the global memory (GM).

- All units can read the 000H to 007H area of the global memory (GM) to obtain the data written by the 00 (0x00) station.
- All units can read the 1F8H to 1FFH area of the global memory (GM) to obtain the data written by the 63 (0x3F) station.

14.6 Software

CUnet master board and software are required for CUnet communication.

Using the software, the CUnet communication status and the input/output status of the unit can be controlled on the PC screen.

	Manufacturer	Model name
CUnet master board	StepTechnica Co., Ltd.	CU-43USB
Software	StepTechnica Co., Ltd.	ASSIST-CU

14.7 Global Memory (GM) Map

SA: Station Address

GM: Global Memory

DOSA: Data Output Station Address

(1) Number of occupied (OWN) items: 1 item

SA	GM+0	GM+2	GM+4	GM+6
16bit signed	PV (CH1)	PV (CH2)	PV (CH3)	PV (CH4)

DOSA	GM+0	GM+2	GM+4	GM+6
16bit signed	SV setting (CH1)	SV setting (CH2)	SV setting (CH3)	SV setting (CH4)

(2) Number of occupied (OWN) items: 2 items

SA	GM+0	GM+2	GM+4	GM+6	GM+8	GM+10	GM+12	GM+14
16bit signed	PV (CH1)	Status flag 1 (CH1)	PV (CH2)	Status flag 1 (CH2)	PV (CH3)	Status flag 1 (CH3)	PV (CH4)	Status flag 1 (CH4)

DOSA	GM+0	GM+2	GM+4	GM+6	GM+8	GM+10	GM+12	GM+14
16bit signed	SV setting (CH1)	Control Allowed /Prohibited selection (CH1)	SV setting (CH2)	Control Allowed /Prohibited selection (CH2)	SV setting (CH3)	Control Allowed /Prohibited selection (CH3)	SV setting (CH4)	Control Allowed /Prohibited selection (CH4)

(3) Number of occupied (OWN) items: 3 items

SA	GM+0	GM+2	GM+4	GM+6	GM+8	GM+10	GM+12	GM+14
16bit signed	PV (CH1)	Status flag 1 (CH1)	MV (CH1)	PV (CH2)	Status flag 1 (CH2)	MV (CH2)	PV (CH3)	Status flag 1 (CH3)
SA	GM+16	GM+18	GM+20	GM+22				
16bit signed	MV (CH3)	PV (CH4)	Status flag 1 (CH4)	MV (CH4)				

DOSA	GM+0	GM+2	GM+4	GM+6	GM+8	GM+10	GM+12	GM+14
16bit signed	SV setting (CH1)	Control Allowed/Prohibited selection (CH1)	Auto/Manual control selection (CH1)	SV setting (CH2)	Control Allowed/Prohibited selection (CH2)	Auto/Manual control selection (CH2)	SV setting (CH3)	Control Allowed/Prohibited selection (CH3)
DOSA	GM+16	GM+18	GM+20	GM+22				
16bit signed	Auto/Manual control selection (CH3)	SV setting (CH4)	Control Allowed/Prohibited selection (CH4)	Auto/Manual control selection (CH4)				

(4) Number of occupied (OWN) items: 4 items

SA	GM+0	GM+2	GM+4	GM+6	GM+8	GM+10	GM+12	GM+14
16bit signed	PV (CH1)	Status flag 1 (CH1)	MV (CH1)	SV (CH1)	PV (CH2)	Status flag 1 (CH2)	MV (CH2)	SV (CH2)
SA	GM+16	GM+18	GM+20	GM+22	GM+24	GM+26	GM+28	GM+30
16bit signed	PV (CH3)	Status flag 1 (CH3)	MV (CH3)	SV (CH3)	PV (CH4)	Status flag 1 (CH4)	MV (CH4)	SV (CH4)

DOSA	GM+0	GM+2	GM+4	GM+6	GM+8	GM+10	GM+12	GM+14
16bit signed	SV setting (CH1)	Control Allowed/Prohibited selection (CH1)	Auto/Manual control selection (CH1)	Manual MV setting (CH1)	SV setting (CH2)	Control Allowed/Prohibited selection (CH2)	Auto/Manual control selection (CH2)	Manual MV setting (CH2)
DOSA	GM+16	GM+18	GM+20	GM+22	GM+24	GM+26	GM+28	GM+30
16bit signed	SV setting (CH3)	Control Allowed/Prohibited selection (CH3)	Auto/Manual control selection (CH3)	Manual MV setting (CH3)	SV setting (CH4)	Control Allowed/Prohibited selection (CH4)	Auto/Manual control selection (CH4)	Manual MV setting (CH4)

When setting by CUnet communication, please set within the range of the module.

The data out of the setting range will be invalid.

For items not covered by global memory (GM), set them in the console software of each module or via e-mail communication.

14.8 Attached Function

Automatic recognition function of connection modules

At power-on, the configuration of connected modules is checked and the data of modules whose connection is recognized is expanded in global memory (GM).

15 Action Explanation

15.1 Control Action Explanation

With the control action selection, any control type can be selected from 2 DOF PID control, Fast-PID control, Slow-PID control, ON-OFF control, or Gap-PID control.

The control action selection can be selected only when control prohibited.

When the integration time is set to 0 or 0.0, Slow-PID control cannot be selected.

Optimum control is possible by selecting the control type according to the intended use and process.

The factory default settings of the control parameters when switching the control type are shown below.

Control parameter \ Control type	2 DOF PID control	Fast-PID control	Slow-PID control	ON-OFF control	Gap-PID control
Proportional band	No update	No update	No update	No update	No update
Integral time	No update	No update	No update	No update	No update
Derivative time	No update	No update	No update	No update	0
Proportional gain 2 DOF coefficient (α) (*1)	0.40	1.00	1.00	1.00	1.00
Integral 2 DOF coefficient (β) (*1)	1.35	1.00	1.00	1.00	1.00
Derivative 2 DOF coefficient (γ, C_d) (*2)	0.00	0.00	0.00	0.00	1.00
Desired value proportional coefficient (C_p) (*2)	1.00	1.00	0.00	1.00	1.00

(*1): Do not change anything other than 2 DOF PID control.

(*2): Do not change.

Rising characteristics / Disturbance characteristics

The rising and disturbance characteristics of 2 DOF PID control, Fast-PID control, and Slow-PID control are shown below.

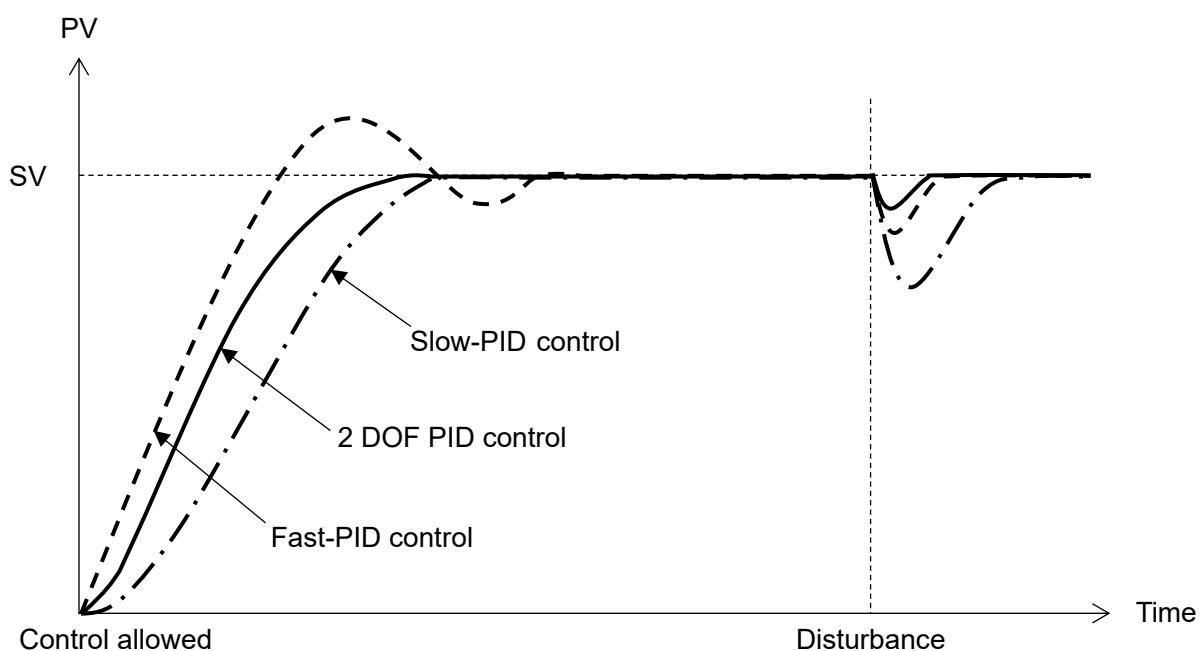

(Fig. 15.1-1)

Target value tracking / Disturbance suppression

The characteristic maps for target value tracking and disturbance suppression of 2 DOF PID control, Fast-PID control, and Slow-PID control are shown below.

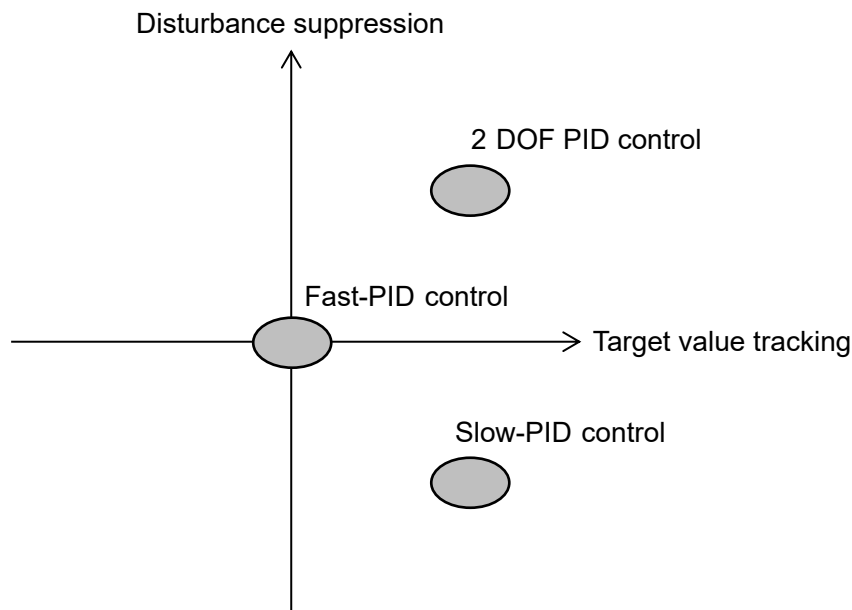

(Fig. 15.1-2)

The number of main control parameters used in control type is shown below.

Control type	Main control parameter
2 DOF PID control	6 [Proportional band, Integral time, Derivative time, Proportional gain 2 DOF coefficient (α), Integral 2 DOF coefficient (β), Proportional cycle]
Fast-PID control	4 [Proportional band, Integral time, Derivative time, Proportional cycle]
Slow-PID control	4 [Proportional band, Integral time, Derivative time, Proportional cycle]
ON-OFF control	1 [ON/OFF hysteresis]
Gap-PID control	6 [Proportional band, Integral time, Derivative time, Proportional cycle, Gap width, Gap coefficient]

15.1.1 2 DOF PID Control

The 2 DOF PID control is control type that achieves both “following characteristics when SV is changed” and “disturbance suppression”.

The 2 DOF means that the above two characteristics can be adjusted independently.

“Following characteristics when SV is changed” is adjusted by proportional gain 2 degrees of freedom coefficient (α) and integral 2 degrees of freedom coefficient (β), and “disturbance suppression” is adjusted by proportional band, integral time and derivative time.

The table below shows the relationship between response speed, overshoot/undershoot, and steady state arrival time depending on the settings of Proportional gain 2 DOF coefficient (α) and Integral 2 DOF coefficient (β).

	When Proportional gain 2 DOF coefficient (α) is increased	When Integral 2 DOF coefficient (β) is increased
Response speed	Become fast	
Overshoot / Undershoot	Become large	Become small
Steady state arrival time		Become slow

The Proportional gain 2 DOF coefficient (α) and the Integral 2 DOF coefficient (β) have set up the optimal value as a factory default value in the usual control.

15.1.2 Fast-PID Control

The Fast-PID control is a general control type for fixed value control.

15.1.3 Slow-PID Control

The Slow-PID control is a control type that is effective for processes that do not want to generate overshoot or for processes in which PV does not easily drop once PV exceeds SV.

15.1.4 ON-OFF Control

The control output is turned on when PV is lower than SV, and the control output is turned off when PV exceeds SV.

Overshoot, undershoot, and hunting will occur.

The ON-OFF control is suitable for processes that do not require accuracy.

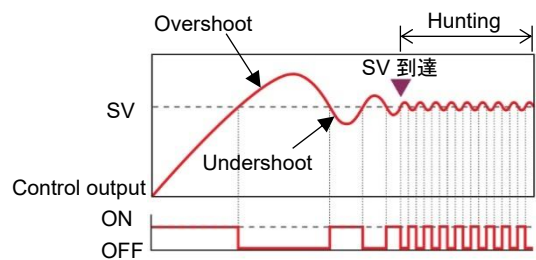

(Fig. 15.1.4-1)

Overshoot / Undershoot

As shown in (Fig. 15.1.4-1), if the temperature of the controlled object rises, it may exceed SV significantly. This is called overshoot.

Also, lowering the temperature from the SV is called undershoot.

Hunting

As shown in (Fig. 15.1.4-1), it means the state when the control result becomes oscillatory.

15.1.5 Gap-PID Control

If the PV is noisy or the operating part has hysteresis, a slight fluctuation may continue near the deviation of zero. In such a case, the dead zone is usually used, but since control is not performed within the dead zone, PV changes during a disturbance.

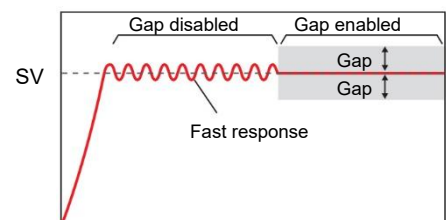

(Fig. 15.1.5-1)

It is suitable for fast response processes such as flow rate and valves.

15.1.6 PID Control Parameters

P control, PI control, PD control or deviation PID control can be performed by setting the PID control parameter.

(1) P control

When the integral time and derivative time are set to 0, P control is performed. P control is a control operation that outputs a manipulated variable proportional to the deviation between SV and PV within the proportional band. Control output is ON until PV reaches point A. When it exceeds this (when it enters the proportional band), the control output starts to turn ON/OFF in the proportional cycle, and when it exceeds SV, the control output turns OFF.

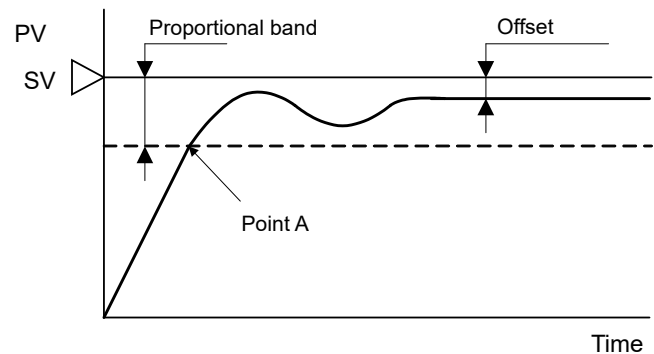

(Fig. 15.1.6-1)

As the temperature rises from point A to SV, the control output ON time becomes shorter and the OFF time becomes longer. Compared to ON-OFF control, overshoot is eliminated and hunting is reduced, but offset occurs.

P control is suitable for processes with no dead time such as gas pressure control and level control.

- When the proportional band is reduced, the control output turns ON/OFF from around SV, so the time until the PV temperature rises to SV becomes shorter and the offset becomes smaller, but hunting becomes larger. If the proportional band is made extremely small, the control will be similar to the ON-OFF control.
- When the proportional band is increased, the control output turns ON/OFF from a temperature considerably lower than SV, so overshoot and hunting are reduced, but it takes time for PV to rise to SV, and also for SV and PV. The offset will also increase.

(2) PI control

When the derivative time is set to 0, PI control is performed. In PI control, the offset generated by P control is automatically corrected by the integral action, and temperature control is performed with SV. However, it takes time for the temperature to stabilize even if the temperature changes rapidly due to disturbance. PI control is suitable for temperature control, which changes slowly.

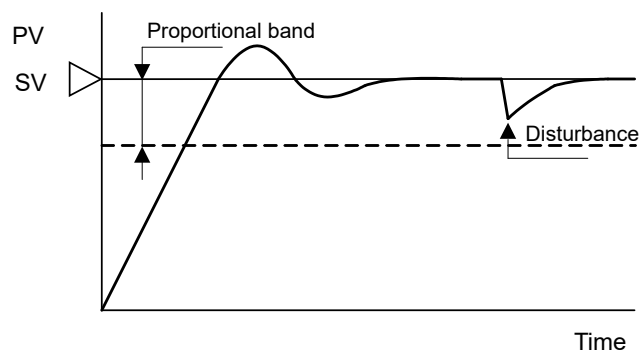

(Fig. 15.1.6-2)

- If the integral time is too short, the integral action will be strong and the offset can be corrected in a short time, but this may cause hunting with a long cycle.
- If the integral time is too long, the integral action will be weak and it will take time to correct the offset.

(3) PD control

When the integral time is set to 0, PD control is performed.

Compared to P control, PD control has a quicker response to rapid temperature changes due to disturbances, stabilizes control in a short time, and improves transient response characteristics.

PD control is suitable for temperature control with fast changing speed.

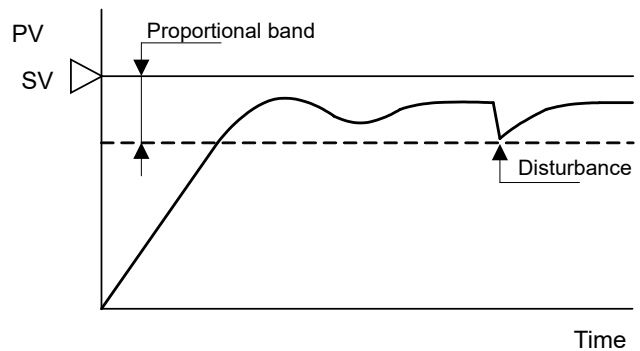

(Fig. 15.1.6-3)

- Decreasing the derivative time weakens the derivative action and delays the response to rapid temperature changes. Also, since the function of suppressing a rapid temperature rise is weakened, the temperature rise time up to SV is shortened, but overshooting tends to occur correspondingly.
- Increasing the derivative time strengthens the derivative action, resulting in faster response to rapid temperature changes. Also, since the function of suppressing a sudden temperature rise becomes stronger, the temperature rise time to SV becomes slower, but overshooting is less likely to occur.

(4) Deviation PID control



Caution

The proportional gain 2 DOF coefficient (α) and the derivative 2 DOF coefficient (γ , Cd) must be set only when using deviation PID control.

For other controls, do not change The proportional gain 2 DOF coefficient (α) and the derivative 2 DOF coefficient (γ , Cd).

When the Fast-PID control is selected in the control action selection and the proportional gain 2 DOF coefficient (α) is set to 1.00 and the derivative 2 DOF coefficient (γ) is set to 1.00, the deviation PID control is performed.

The feature of deviation PID control is that only the response after SV change is fast.

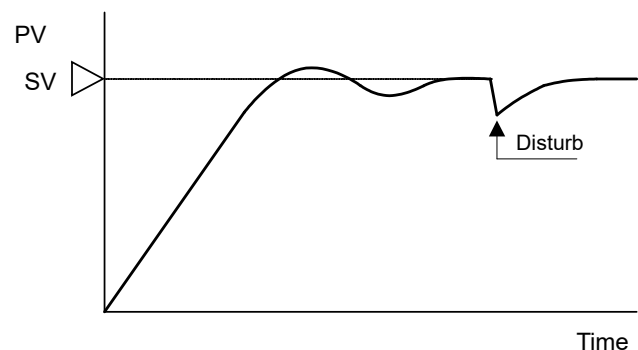

(Fig. 15.1.6-4)

It is suitable for program control and cascade control using the SV rise rate and SV fall rate. It is not suitable for processes that cannot accept sudden changes in MV.

15.2 Standard Function

15.2.1 Control Range

If the control range below is exceeded, the control output will turn OFF.

Control range for thermocouple input (no decimal point)

Input range low limit - 50°C (90°F) to Input range high limit + 50°C (90°F)

Control range for thermocouple input (with decimal point) and RTD input

Input range low limit - (Input span × 1%) °C (°F) to Input range high limit + 50.0°C (90°F)

Control range for direct current input and DC voltage input

Scaling low limit - Scaling width × 10% to Scaling high limit + Scaling width × 10%

15.2.2 Proportional band decimal point position selection

For the direct current input and DC voltage input ranges, the decimal point position of the proportional band can be changed. Since the proportional band of the direct current input and DC voltage input ranges corresponds to a percentage of the full scale, it can be used differently depending on the intended use, such as when detailed settings are desired or when the sensitivity of the control response is to be reduced.

15.2.3 Integral/Derivative Decimal Point Position

Select whether the integral time or the derivative time has no decimal point or has a decimal point. When there is no decimal point and there is a decimal point, it is automatically converted to a value 0.1 times the current set value.

Also, when the decimal point is changed to the one without a decimal point, the value is automatically converted to 10 times the current set value.

If the setting goes out of the setting range by changing the position of the decimal point, it becomes the setting range upper limit value or lower limit value.

15.2.4 MV Bias

When performing control, an offset may occur without reaching SV.

In such a case, it is a function that can be added to MV.

15.2.5 Control action selection when input error

The user can select whether to continue the control operation when the input becomes an input error, overscale, or underscale, or whether to output the fixed operation amount set in the input error operation amount setting.

Setting range

0: Input error operation setpoint

0.0 to 100.0 % (for DC current output and DC voltage output: -5.0 to 105.0 %)

1: Control operation continues

15.2.6 Output Minimum ON/OFF Time

When the MV is other than 0% or 100%, the output can be turned ON or OFF without depending on the MV by setting the output minimum ON/OFF time. However, when the auto balance control function is selected, it becomes invalid.

When output is ON

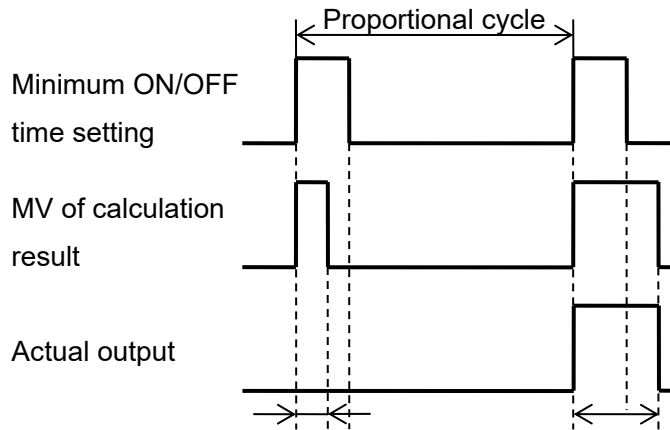

Output OFF when the MV ON time of the calculation result is shorter than the minimum ON/OFF time.

Output ON at the calculation result MV when the ON time of the operation result MV is longer than the minimum ON/OFF time.

(Fig. 15.2.6-1)

When output is OFF

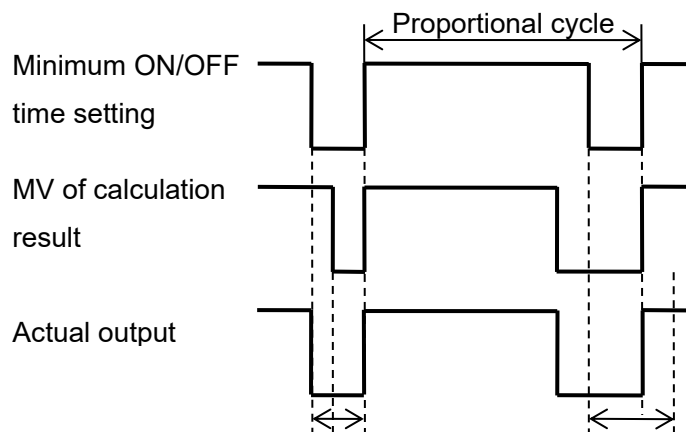

Output is turned OFF at the minimum ON/OFF time when the calculated MV OFF time is shorter than the minimum ON/OFF time.

Output of the calculated result MV is OFF when the calculated result MV OFF time is longer than the minimum ON/OFF time.

(Fig. 15.2.6-2)

15.2.7 Alarm Output

For Alarm output, the alarm value is set by \pm deviation from the SV (excluding Process alarm), and if the input goes outside the range, the Alarm output is turned ON (turned OFF for High/Low limit range alarm).

Select High limit alarm, Low limit alarm, High/Low limits alarm, High/Low limit s range alarm, Process High alarm, Process Low alarm, High limit with standby alarm, Low limit with standby alarm, High/Low limits alarm with standby alarm, High/Low limits alarm individually, High/Low limit s range alarm individually, High/Low limits alarm with standby individually or No action.

Refer to “15.5.3 Alarm Operation Diagram (P.15-34, P.15-35)” for detail of alarm action.

Alarm value 0 Enable/Disable selection

When the alarm value is 0, select whether to enable or disable the alarm value.

If select enabled, set the alarm value to 0 in High limit alarm, Low limit alarm, High/Low limits alarm, High/Low limit s range alarm, High limit with standby alarm, Low limit with standby alarm, High/Low limits alarm with standby alarm, High/Low limits alarm individually, High/Low limits range alarm individually and High/Low limits alarm with standby individually to activate the alarm action.

15.2.8 Loop Break Alarm

Detects actuator trouble (heater burnout, sensor burnout).

When control action is Reverse action

When the PV does not rise above the loop break alarm action width setting within the loop break alarm time, even if MV reaches 100% or the output high limit, the loop break alarm is activated.

When the PV does not fall above the loop break alarm action width setting within the loop break alarm time, even if MV reaches 0% or the output low limit, the loop break alarm is activated.

When control action is Direction action

When the PV does not fall above the loop break alarm action width setting within the loop break alarm time, even if MV reaches 100% or the output high limit, the loop break alarm is activated.

When the PV does not rise above the loop break alarm action width setting within the loop break alarm time, even if MV reaches 0% or the output low limit, the loop break alarm is activated.

15.2.9 Set Value Ramp Functio

When the SV is changed, from before to after the change SV is controlled at the setting change rate.

When the power is turned on, the rate of change from PV to SV at that time is controlled.

If set to 0, this function will not work.

15.2.10 Power On Restore Action

When the power is turned on, select whether to resume in the continuous state (state before turning off the power) or in the stopped state.

	Power-on restore action selection			
	0: Stopped state (Return to automatic control)		1: Continuous state (Return to automatic control)	
	Control allowed	Control prohibited	Control allowed	Control prohibited
Auto control	Auto control Control stop	Auto control Control prohibited	Auto control Control allowed	Auto control Control prohibited
Manual control	Auto control Control stop	Auto control Control prohibited	Auto control Control allowed	Auto control Control prohibited

	Power-on restore action selection			
	2: Stopped state (Return to previous state)		3: Continuous state (Return to previous state)	
	Control allowed	Control prohibited	Control allowed	Control prohibited
Auto control	Auto control Control stop	Auto control Control prohibited	Auto control Control allowed	Auto control Control prohibited
Manual control	Manual control Control stop	Manual control Control prohibited	Manual control Control allowed	Manual control Control prohibited

15.2.11 Non-volatile IC Memory Data Save

Select whether to allow or prohibit saving data to the non-volatile IC memory.

If you select save prohibition, can temporarily change all the set values, but if turn the power off and then on, it will return to the value before selecting save prohibition.

15.2.12 Auto/Manual Control Switching

Switches between automatic control and manual control.

When switching from automatic control to manual control or from manual control to automatic control, the balanceless bumpless function prevents sudden changes in MV.

MV can be set arbitrarily by switching to manual control. (*)

Manual control MV setting range: -5.0 to 105.0 %

When the power is turned on again, it is restored with the control action selected in the power-on restore action selection.

(*): If the sensor fails in manual control, the MV will be 0%.

15.2.13 Sensor Correction Factor

Set the slope of the sensor input value.

The sensor correction factor setting is calculated by the following formula.

Sensor correction factor setting = $(Y' - X') / (Y - X)$

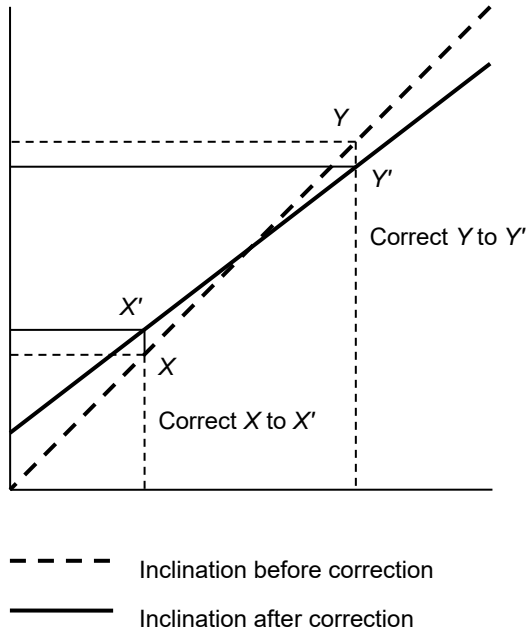

(Fig. 15.2.13-1)

15.2.14 Sensor Correction

If the temperature at the control location and the temperature at the sensor location are different, PV is corrected.

However, it is valid within the input rated range regardless of the sensor correction value.

PV after input correction is expressed by the following formula.

PV after input correction =

Current PV × Sensor correction factor setting value + (Sensor correction setting value)

15.2.15 Output Rate-of-Change Limit

When PV is lower than SV in heat control, the normal output changes from OFF to ON as shown in (Fig. 15.2.15-1), but set the output change rate limit value, the output change rate can be changed as shown in (Fig. 15.2.15-2).

Set the MV that changes for 1 second.

If 0 is set, this function will not work.

It is suitable for controlling high-temperature heaters (components containing molybdenum, tungsten, platinum, etc., used at about 1500 to 1800°C) that will be cut off when electricity is applied rapidly.

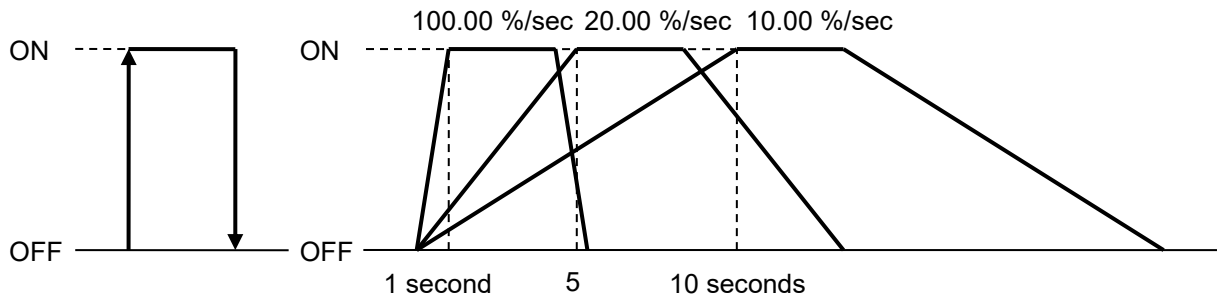

(Fig. 15.2.15-1)

(Fig. 15.2.15-2)

15.2.16 Control Function

Select Standard, Heating/Cooling control, Cascade control or Output selection function, for control function selection.

The control function selection can be selected only when control prohibited.

(1) Heating/Cooling control

The heating/cooling control is a control that is combined with cooling operation when it is difficult to control the temperature control of the controlled object only by heating operation.

The control result calculated according to SV and PV is divided into heating output and cooling output and output.

When PV is larger than SV, cooling output is output.

When PV is smaller than SV, heating output is output.

It is possible to set the band that outputs both heating output and cooling output (overlap), and the band that does not output both (dead band).

Also, the cooling action mode can be selected from Air cooling (Linear characteristics), Oil cooling (1.5th power of the linear characteristic s) or Water cooling (2nd power of the linear characteristic).

The output characteristics are as shown below for cooling MV.

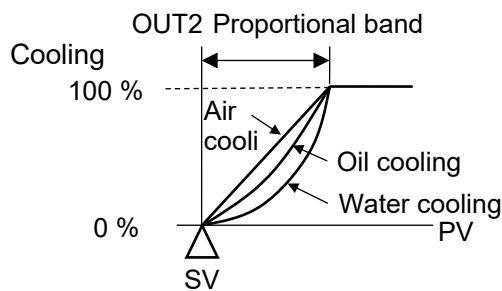

(Fig. 15.2.16-1)

For processes that generate heat (extruders, etc.) and temperature control near room temperature (environmental testers, etc.), heating and cooling control that performs both heating and cooling operations for the controlled object is effective.

When heating/cooling control is selected for CH1 in control function selection, CH1 becomes heating output and CH2 becomes cooling output.

When heating/cooling control is selected for CH3 in control function selection, CH3 becomes heating output and CH4 becomes cooling output.

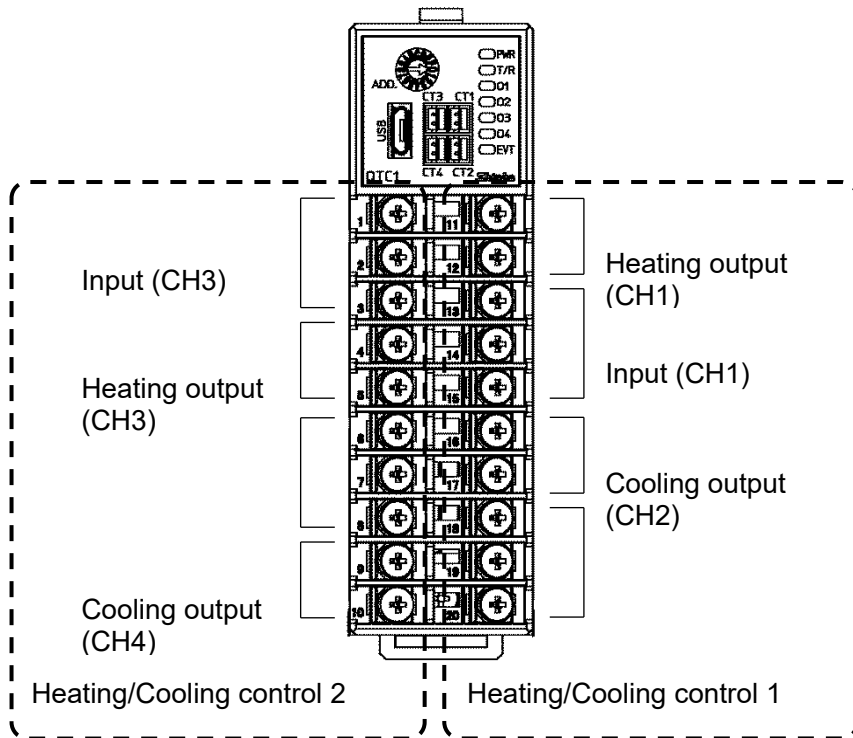

(Fig. 15.2.16-2)

(2) Cascade control

The cascade control is a method of combining two PID controls to form one feedback loop and controlling.

This is effective when controlling a control target that has an extremely long delay time or dead time from the change of MV to the measurement of the control target.

Although it takes longer for PV to reach SV, highly stable control is possible.

When the cascade control is selected for CH1 in the control function selection, the cascade control is performed with CH1 as the master and CH2 as the slave.

When the cascade control is selected for CH3 in the control function selection, the cascade control is performed with CH3 as the master and CH4 as the slave.

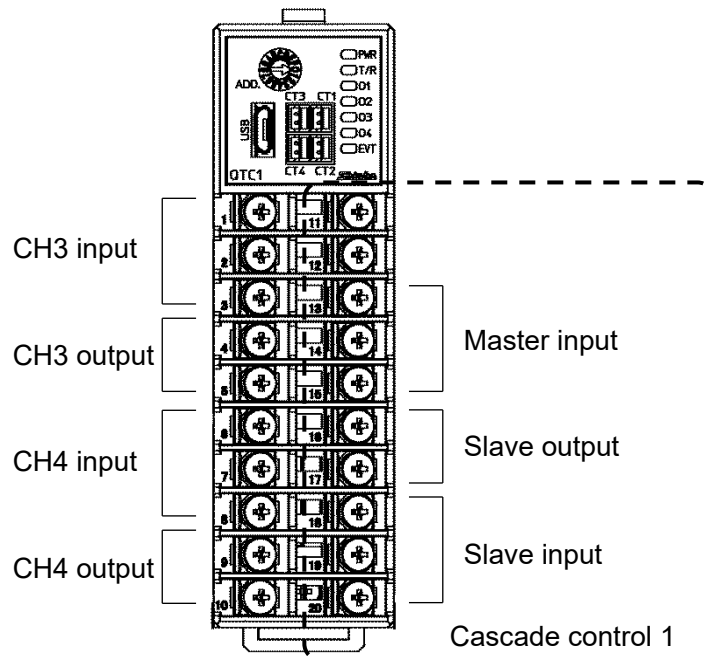

(Fig. 15.2.16-3)

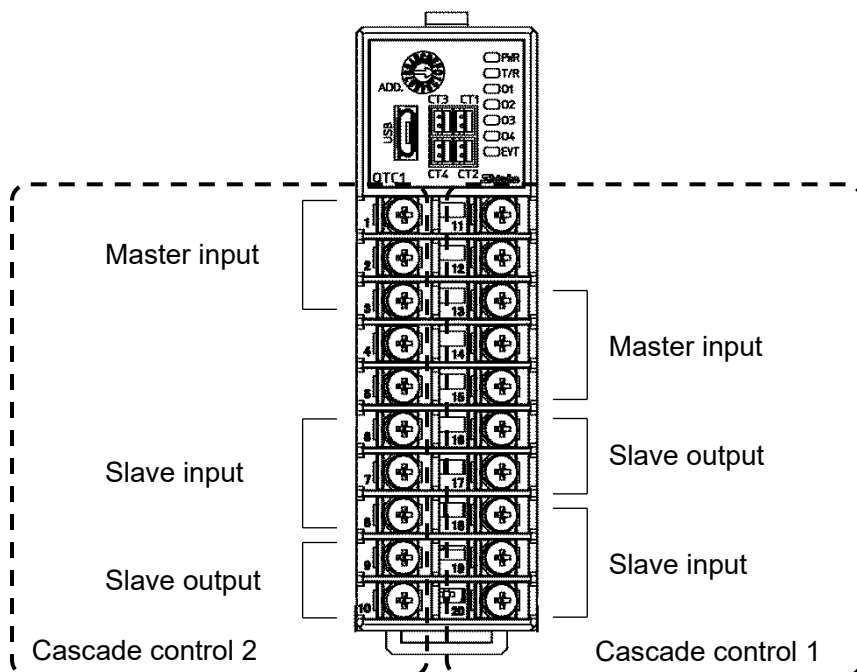

(Fig. 15.2.16-4)

The MV on the master side obtained from the SV on the master side (CH1 or CH3) and PV is substituted for the SV on the slave side (CH2 or CH4), and the slave side performs control calculation and controls on the MV on the slave side.

The control output on the master side is OFF (0 mA for current output).

MV (0 to 100%) on the master side is converted according to the setting of slave scale low limit value to slave scale high limit value, and becomes SV on the slave side.

For example, if the slave scale low limit value is 100°C and the slave scale high limit value is 400°C, the master side MV is 0% 100°C, 50% 200°C, 100% 400°C is the SV on the slave side. It is necessary to design the system so that the control on the slave side has less delay than the control on the master side and a quick control response can be obtained.

(Example)

This is an application that selects the cascade control for CH1 in control function selection, uses CH1 as the master and CH2 as the slave, and adjusts the heat quantity of the heater using the power controller to adjust the temperature of the controlled object.

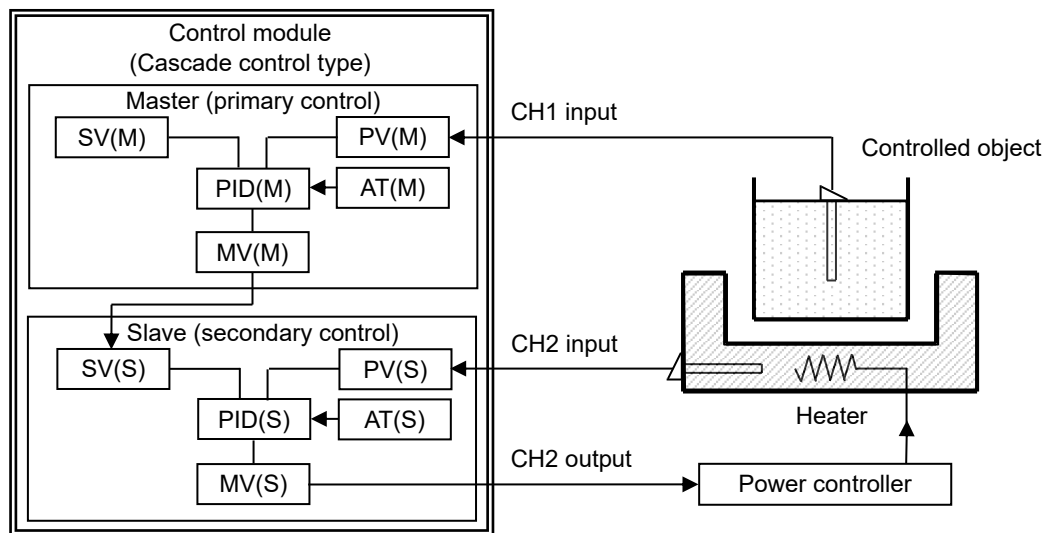

(Fig. 15.2.16-5)

AT for cascade control

Execute AT in cascade control according to the following procedure.

- Slave side (CH2) AT

- ① Set SV (AT point) on slave side (CH2).
- ② Select AT Perform in AT Perform/Cancel on the slave side (CH2).

After AT is completed, each PID setting value on the slave side (CH2) is automatically set.

- Master side (CH1) AT

- ① Set SV on master side (CH1).
- ② Select AT Perform in AT Perform/Cancel on the master side (CH1).

After AT is completed, each PID setting value on the master side (CH1) is automatically set.

Depending on the controlled object, the optimum PID settings may not be obtained.

In such a case, refer to each PID setting value after AT is completed and set manually.

(3) Output selection function

If the used channel fails, the input can be changed to an unused channel and the output location for the input can be selected.

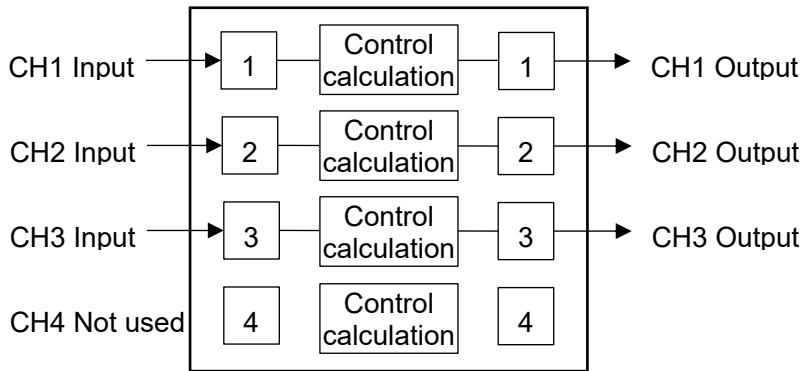

(Fig. 15.2.16-6)

If the input or output fails, you can select the input channel for the output of each channel by selecting the output channel.

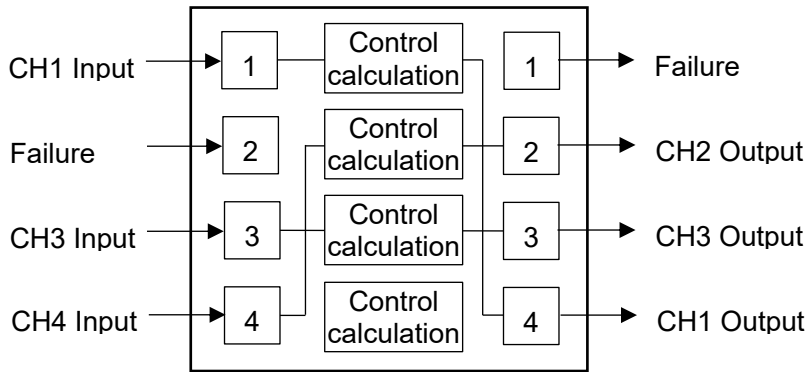

(Fig. 15.2.16-7)

The same output can be output up to 4 points for one input.

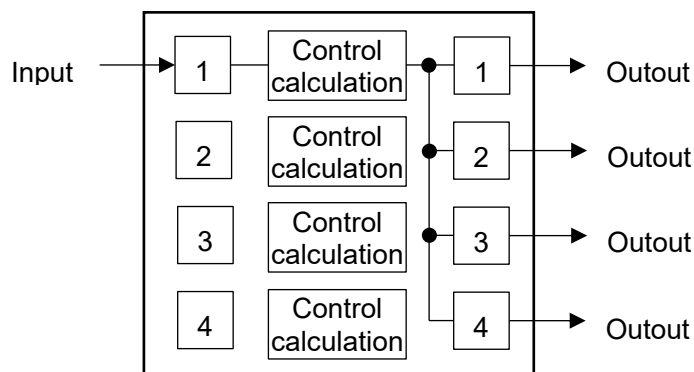

(Fig. 15.2.16-8)

15.3 Extension function

15.3.1 Extension function selection

In the Extension function selection, select "Without expanded function", "Peak power suppression function" or "Auto balance control function".

(1) Peak power suppression function

This function suppresses the peak power value when there is a power limit for the facility.

By setting the total current, power suppression is controlled when the sum of the current values set for each channel is less than or equal to the total current value. However, this function does not work for DC current output and DC voltage output.

The change of each set value is effective only when control is inhibited.

Output timing during peak power suppression function

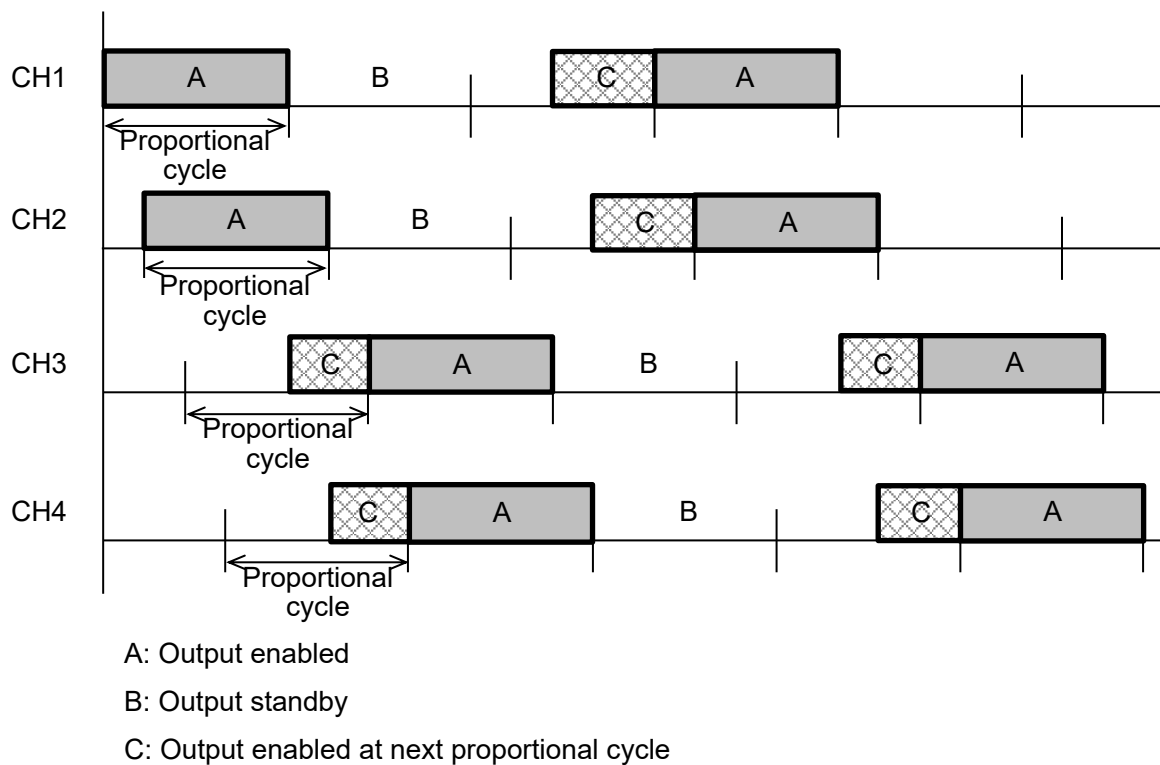

(Fig. 15.3.1-1)

Current judgment

The current value is judged for each proportional cycle of each channel, and the channel that becomes "Control output enabled", "Control output standby", or "Control output enabled at next proportional cycle" is judged.

Conditions for enabling the peak power suppression function

The peak power suppression function will be enabled in the following cases.

- When the input is not the input error, overscale or underscale during control prohibition
- When Control Enable is selected in Control Enable/Prohibited selection

Conditions for disabling the peak power suppression function

The peak power suppression function will be disabled in the following cases.

- When the input is not the input error, overscale or underscale during control prohibition
- When Control Prohibited is selected in Control Enable/Prohibited selection
- When ON/OFF control action is selected in Control action selection

AT when the Peak Power Suppression function is enabled

When the peak power suppression function is enabled, the output is allocated so that it does not exceed the total current setting value, so AT cannot be executed because it may exceed the total current setting value if AT is executed.

(2) Auto balance control function

This function suppresses partial burning and mechanical strain by performing soaking on one control target at multiple control points.

Setting procedure of auto balance control

Describes the procedure for auto balance control.

- ① Selection of Module Address
Extension Function Selection (P.8-32)", select module addresses from 1 to consecutive numbers.
- ② Select Auto balance control function in Extension function selection.
- ③ Select Interlock or Alone in Auto balance control interlock/alone selection.
- ④ Select Master channel or Slave channel in Auto balance control master/slave selection.
- ⑤ Select Enabled or Disabled in Auto balance control Enabled/Disabled selection.
- ⑥ Set the number of modules managed by the master module in Number of communication management module setting (when Interlock is selected in Auto balance control interlock/alone selection).
- ⑦ Select Allowed in Control Allowed/Prohibited selection.

Operation explanation of auto balance control

When using the communication expansion module QMC1-C□, QMC1-C□ becomes the master and transfers data between control modules.

When the communication expansion module QMC1-C□ is not used, the control module QTC1-4P (with power supply / communication option) becomes the master, and the master channel and slave channel are selected from the master input channel by auto balance control master/slave selection.

The auto balance control function does not work when the master channel is not selected.

When Enabled is selected for Auto balance control Enabled/Disabled selection, control prohibited is changed to control allowed to start auto balance control.

The slave channels that are allowed to control within 10 seconds from the master channel on which autobalance control was started are the target channels for autobalance control.

Slave channels that have been allowed to control after 10 seconds have passed (during automatic balance control operation) are excluded from normal operation and are controlled

normally.

When the auto balance control function operates, the SV of the slave channel heats up according to the PV of the master channel.

If the master channel has an input error, cancel the auto balance control function.

Slave channels that have no input error are individually controlled normally.

The set value ramp function is disabled during auto balance control.

It is also invalid when 2 DOF PID control, Fast-PID control, ON-OFF control or Gap-PID control is selected in control action selection.

When using the auto balance control function, the same input range is used for the inputs that are used for auto balance control.

For direct current input and DC voltage input, set the scaling high limit and scaling low limit to the same setting.

Slave channel SV of auto balance control

Slave channel SV of auto balance control =

$$\text{Master channel PV} + (\text{Slave channel SV} - \text{Master channel SV})$$

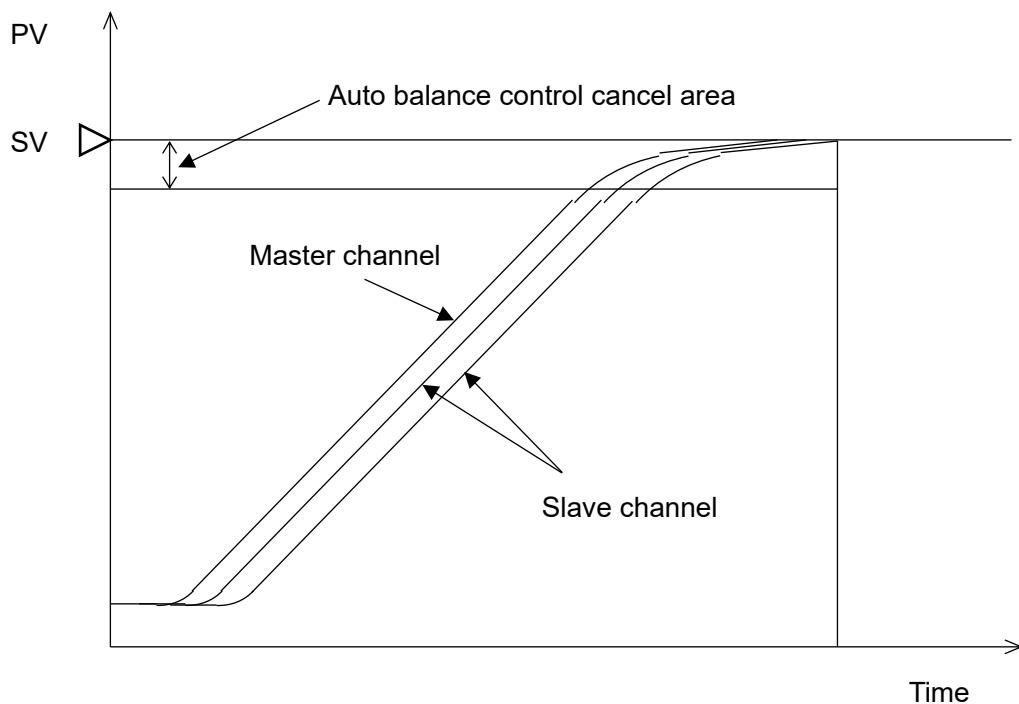

(Fig. 15.3.1-2)

Auto balance control interlock/alone selection

Select whether the auto balance control function is interlock or alone.

Both interlock and alone can be selected within one unit. However, connect the modules for which Interlock is selected continuously for the number of communication management modules.

If the module for which Alone is selected is connected to the modules that are connected in succession, the subsequent modules will not be linked.

- Interlock

Performs the auto balance control between modules.

Auto balance control can be performed as one group within one unit consisting of communication expansion module QMC1-C□ or control module QTC1-4P and control module QTC1-40.

- Alone

Performs auto balance control within the module.

You can use the channels in the control module for auto balance control.

When select interlock and use control module QTC1-4P

Setting example when 6 channels are used for auto balance control with interlock and 6 channels are used for normal control

	Control module 1 QTC1-4P (with power supply/communication option)				Control module 2 QTC1-40 (no power supply/communication option)				Control module 3 QTC1-40 (no power supply/communication option)			
Channel	CH1	CH2	CH3	CH4	CH1	CH2	CH3	CH4	CH1	CH2	CH3	CH4
Auto balance control interlock/alone selection	Interlock				Interlock				Alone			
Auto balance control Enabled/Disabled selection	Enabled		Disabled		Enabled		Disabled		Disabled			
Auto balance control master/slave selection (input channel No.)	1: CH1 Master channel				0: Slave channel				0: Slave channel			

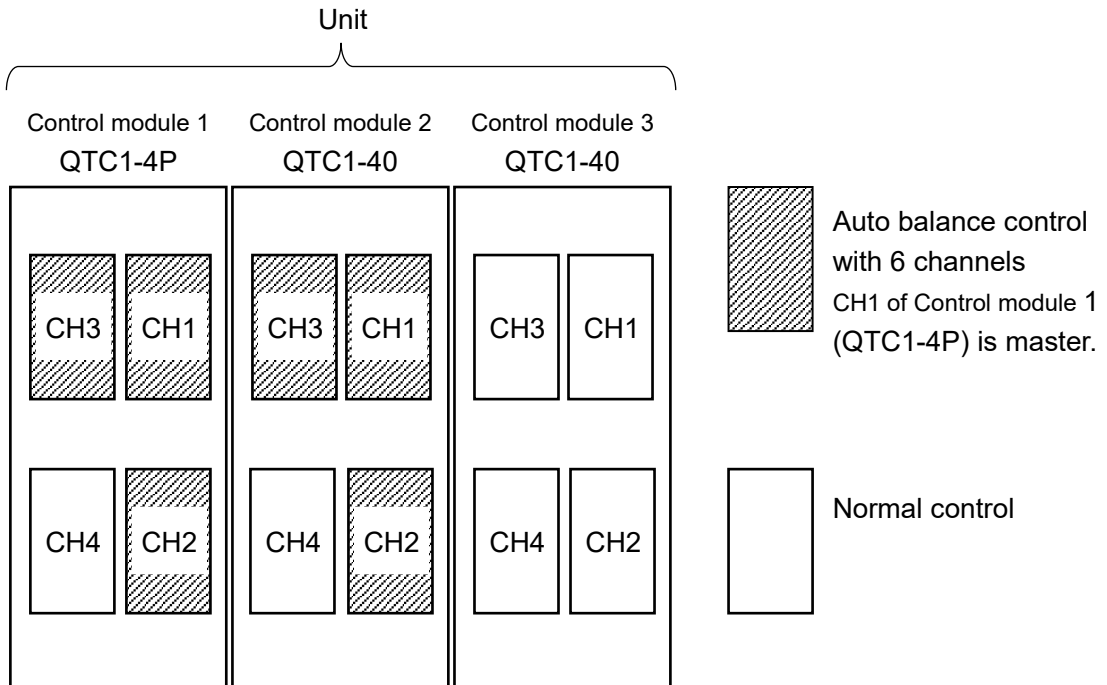

(Fig. 15.3.1-3)

[Description]

- The following channels for which Enabled is selected in Auto balance control Enabled/Disabled selection are grouped as one group, and CH1 of Control module 1 (QTC1-4P) is used as a master for auto balance control.
 - CH1 to CH3 of Control module 1 (QTC1-4P)
 - CH1 to CH3 of Control module 2 (QTC1-40)
- The following channels for which Enabled is selected in Auto balance control Enabled/Disabled selection performs normal control.
 - CH4 of Control module 1(QTC1-4P)
 - CH4 of Control module 2(QTC1-40)
 - CH1 to CH4 of Control module 3(QTC1-40)

When select interlock and use communication expansion module QMC1

Setting example when 6 channels are used for auto balance control with interlock and 6 channels are used for normal control

	Control module 1 QTC1-40 (no power supply/communication option)				Control module 2 QTC1-40 (no power supply/communication option)				Control module 3 QTC1-40 (no power supply/communication option)			
Channel	CH1	CH2	CH3	CH4	CH1	CH2	CH3	CH4	CH1	CH2	CH3	CH4
Auto balance control interlock/alone selection	Interlock				Interlock				Alone			
Auto balance control Enabled/Disabled selection	Enabled		Disabled		Enabled		Enabled		Disabled			
Auto balance control master/slave selection (input channel No.)	2: CH2 Master channel				0: Slave channel				0: Slave channel			

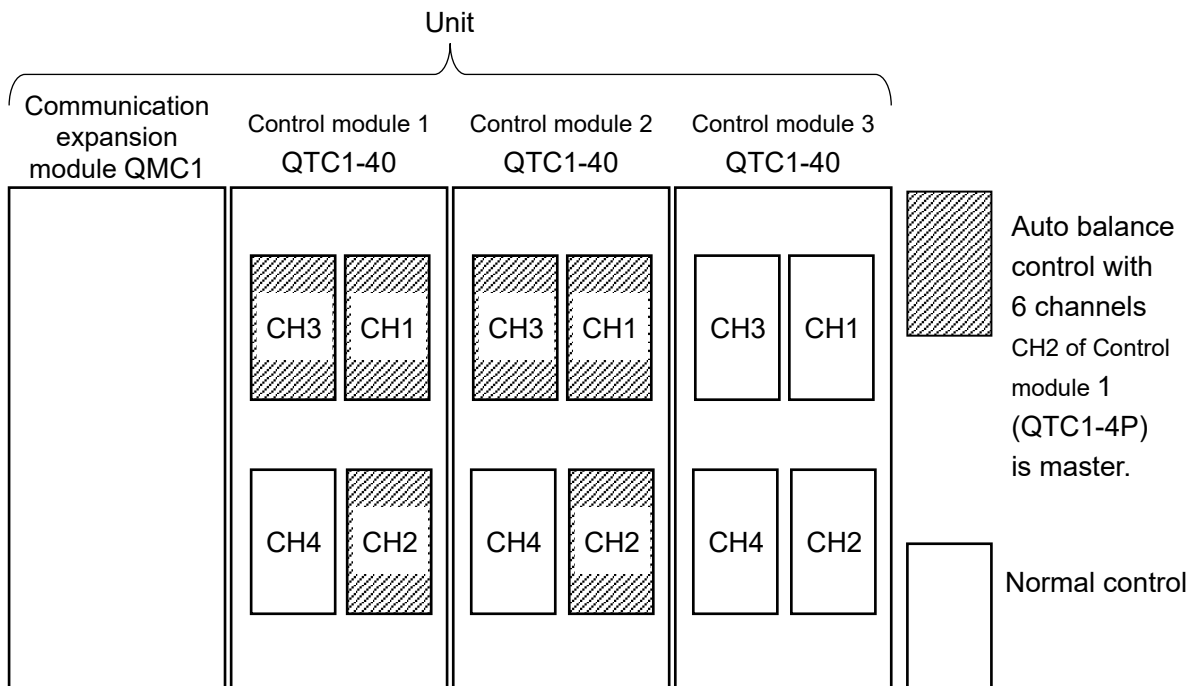

(Fig. 15.3.1-4)

[Description]

- The following channels for which Enabled is selected in Auto balance control Enabled/Disabled selection are grouped as one group, and CH2 of Control module 1 (QTC1-40) is used as a master for auto balance control.
 - CH1 to CH3 of Control module 1(QTC1-40)
 - CH1 to CH3 of Control module 2(QTC1-40)
- The following channels for which Enabled is selected in Auto balance control Enabled/Disabled selection performs normal control.
 - CH4 of Control module 1(QTC1-40)
 - CH4 of Control module 2(QTC1-40)
 - CH1 to CH4 of Control module 3(QTC1-40)
- The communication expansion module (QMC1-C□) transfers data between control modules.

When select alone

Setting example when 4 channels are used for auto balance control with alone and 8 channels are used for normal control

	Control module 1 QTC1-4P(with power supply/communication option)				Control module 2 QTC1-40 (no power supply/communication option)				Control module 3 QTC1-40 (no power supply/communication option)			
Channel	CH1	CH2	CH3	CH4	CH1	CH2	CH3	CH4	CH1	CH2	CH3	CH4
Auto balance control interlock/alone selection	Alone				Alone				Alone			
Auto balance control Enabled/Disabled selection	Disabled				Disabled				Enabled			
Auto balance control master/slave selection (input channel No.)	0: Slave channel				0: Slave channel				4: CH4 Master channel			

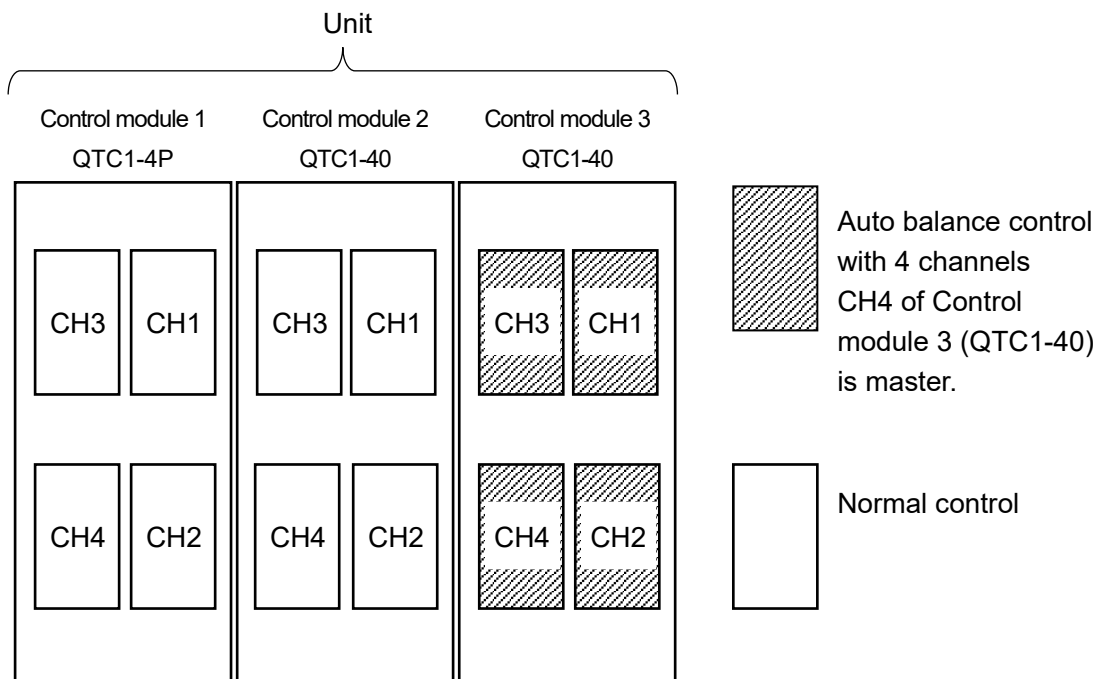

(Fig. 15.3.1-5)

[Description]

- The following channels for which Enabled is selected in Auto balance control Enabled/Disabled selection are grouped as one group, and CH4 of Control module 3 (QTC1-40) is used as a master for auto balance control.
CH1 to CH4 of Control module 3(QTC1-40)
- The following channels for which Disabled is selected in Auto balance control Enabled/Disabled selection performs normal control.
CH1 to CH4 of Control module 1(QTC1-4P)
CH1 to CH4 of Control module 2(QTC1-40)

Auto balance control start output setting

When using the auto balance control function, the target value of the master channel is SV, but the SV of the slave channel becomes the PV of the master channel, so the slave channel does not start the auto balance control unless the master channel heats up. ..

As a result, the temperature of the slave channel is delayed and a temperature difference with the master channel is generated, so that the MV is set so that the output of the slave channel turns on when auto balance control starts in order to prevent deterioration of simultaneity.

The setting value of 0.00 to 1.00 corresponds to 0 to 100%.

Auto balance control start condition setting

The auto balance control is started in the following cases.

- When input is not burnout or underscale
- When AT Cancel is selected in AT Perform/Cancel
- When master is selected in master/slave selection
- When Reverse action is selected in Direct/Reverse action selection
- When the heater burnout alarm or loop break alarm is not generated

Auto balance control cancel condition setting

The auto balance control is canceled in the following cases.

- When input is not burnout or underscale
- When AT Perform is selected in AT Perform/Cancel
- When Direct action is selected in Direct/Reverse action selection
- When a Heater burnout alarm or Loop break alarm occurs on the master channel.

However, if a Heater burnout alarm or Loop break alarm occurs on a slave channel, the auto balance control is canceled only for that channel.

- When Control Prohibited is selected in Control Enable/Prohibited selection

Auto balance control cancel area setting

When the PV of the master channel reaches the autobalance control cancel area and when the PV of each slave channel reaches the autobalance control cancel area, the auto balance control function is released.

Master channel $PV \geq \text{Master channel SV} - \text{Auto balance control cancel area}$

(When 0 is set, the auto balance control cancel area is twice the proportional band of the master channel.)

Slave channel $PV \geq \text{Slave channel SV} - \text{Auto balance control cancel area}$

(When 0 is set, the auto balance control cancel area is twice the proportional band of the master channel.)

Number of communication management module setting

Set the number of units including the master module.

If two slave modules for interlock are connected, set them as three.

15.3.2 Output Gain – Bias Function

When controlling the temperature of the metal plate, the heater is controlled at multiple points. However, if multiple outputs are used for the inputs and the distribution of the output amount is known in advance, the ratio and bias for MV (reference output) can be set to perform uniform control.

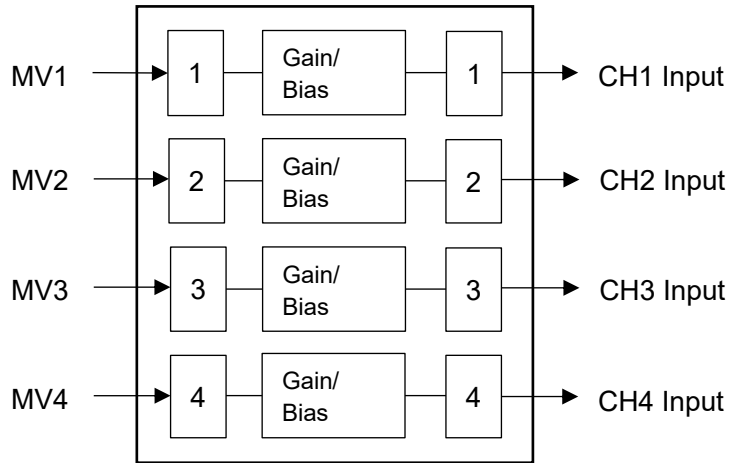

(Fig. 15.3.2-1)

15.3.3 Input Math Function

In Input math function selection, select Standard, Difference input or Addition input.

The input math function selected for CH1 corresponds to CH1 and CH2, and the input math function selected for CH3 corresponds to CH3 and CH4. However, if heating/cooling control, cascade control or output selection function is selected for control function selection, the input math function is invalid.

Standard	The input value of CH is used as PV for control.
Difference input	<p>The temperature difference between CH1 and CH2 is used as the PV for CH1 and is controlled by CH1.</p> $\text{CH1 PV} = \text{CH1 PV} - \text{CH2 PV}$ <p>The temperature difference between CH3 and CH4 is used as the PV for CH3 and is controlled by CH3.</p> $\text{CH3 PV} = \text{CH3 PV} - \text{CH4 PV}$ <p>Each setting value such as scaling and PV filter time constant can be set for each channel.</p> <p>When performing AT with the difference input specifications, execute AT individually for each channel and then select difference input.</p>
Addition input	<p>The added value of CH1 and CH2 is used as the PV for CH1 and is controlled by CH1.</p> $\text{CH1 PV} = \text{CH1 PV} + \text{CH2 PV}$ <p>The added value of CH3 and CH4 is used as the PV for CH3 and is controlled by CH3.</p> $\text{CH3 PV} = \text{CH3 PV} + \text{CH4 PV}$ <p>Each setting value such as scaling and PV filter time constant can be set for each channel.</p> <p>When performing AT with the addition input specifications, execute AT individually for each channel and then select addition input.</p>

15.3.4 Input Difference Selection

Input difference selection detects the input difference between the current channel and the selected channel, and when the input difference detection setting exceeds the set value, the input difference flag of status flag 1 B12: Set "out of range". However, this function does not work when the own channel is selected in input difference selection.

15.3.5 Combination of Functions

(1) About combination of control action selectiton / output selection and control function / extension function

- : Can be combined
- ×: Cannot be combined

Control action selectiton Output selection Control function Extension function	Control action selectiton					Output selection
	2 DOF PID control	Fast-PID control	Slow-PID control	ON/OFF control action	Gap-PID control	
Heating/Cooling control	○	○	○	○	○	×
Cascade control	○	○	○	○	×	×
Peak power suppression function	○	○	○	×	○	×
Auto balance control function	×	×	○	×	×	○
Output gain-bias function	○	○	○	○	○	○
Input math function	○	○	○	○	○	○

(2) About combination of control function and extension function

- : Can be combined
- ×: Cannot be combined (If set, operation cannot be guaranteed)

	Heating/ Cooling control	Cascade control	Peak power suppression function	Auto balance control function	Output gain-bias function	Input math function
Heating/Cooling control		○ (*1)(*2)	×	○(*1)	×	○
Cascade control	○(*1)(*2)		×	×	○(*1)	×
Peak power suppression function	×	×		×	×	×
Auto balance control function	○(*1)	×	×		×	×
Output gain-bias function	×	○(*1)	×	×		×
Input math function	○	×	×	×	×	

(*1): It cannot be used together with output selection.

(*2): When using Heating/Cooling control with one system, you can select Cascade control for CH3 and CH4. When Cascade control is used in one system, CH3 and CH4 can be selected as Heating/Cooling control.

(3) About combinations within modules and units

- : Can be combined
- ×

	Within modules	Within units
Heating/Cooling control	○	×
Cascade control	○	×
Peak power suppression function	○	×
Auto balance control function	○	○
Output gain-bias function	○	×
Input math function	○	×

15.4 Attached Function

15.4.1 Power Failure Countermeasure

The non-volatile IC memory backs up the setting data.

15.4.2 Self-Diagnosis

The watchdog timer monitors runaway and halt of the program, and when an abnormality is detected, it resets the MCU and initializes the instrument.

15.4.3 Automatic Cold Junction Temperature Compensation

Detect the temperature of the connection terminal between the thermocouple and the instrument, and make it the same as if the reference contact is always set to 0°C (32°F). (Only valid for channels for which thermocouple input is selected.)

15.4.4 PV Filter Time Constant

This is a function to stabilize the PV of the process (pressure, flow rate, etc.) where the PV fluctuation before the PV filter processing is performed by performing the temporary delay calculation of the PV before the PV filter processing with the filter function on the software. When PV before PV filter processing changes stepwise as shown in (Fig. 14.4.4-1), if PV time constant (T) is set, PV filter will be set after T seconds as shown in (Fig. 14.4.4-2). It changes to reach 63% of the PV after treatment.

If the set value is too large, the control result may be adversely affected by the delay in response.
PV filter time constant: 0.0 to 10.0 seconds

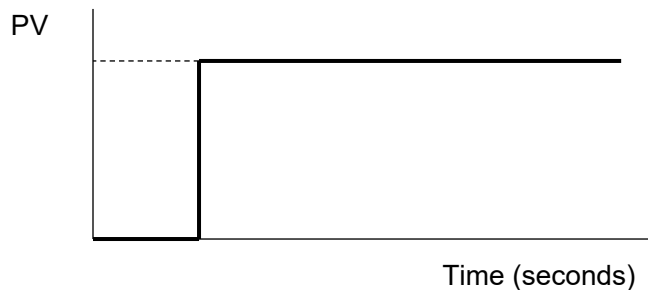

(Fig. 15.4.4-1)

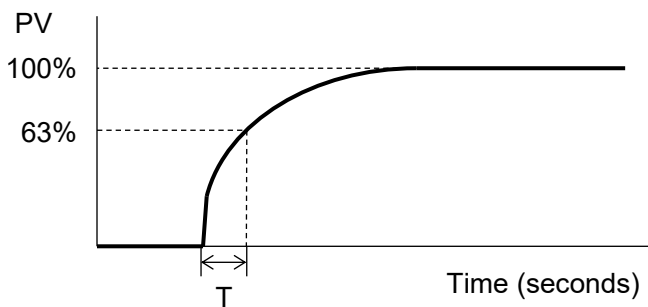

(Fig. 15.4.4-2)

15.4.5 Moving average count

This function stabilizes the indicated value by averaging the value whose input value fluctuates due to noise.

Moving average count: 1 to 10 times

15.4.6 CH Enable/Disable

Select enable or disable for each channel.

When disabled is selected, all operations are disabled for the selected channel and PV becomes 0.

15.4.7 Overscale

In the case of the following input range, overscale will occur and B1: Input error (overscale) of status flag 1 will be set to "1: Error". However, control continues during overscale.

Refer to the relationship between sensor error, overscale, underscale, and control (Fig. 14.4.9-1). (P.14-29)

For thermocouple input (no decimal point)

Rated high limit to Input range high limit + 50°C (90°F)

For thermocouple input (with decimal point) and RTD input

Rated high limit to Input range high limit + 50.0°C (90.0°F)

For direct current input and DC voltage input

Scaling high limit to Scaling high limit + Scaling width × 10%

15.4.8 Underscale

In the case of the following input range, underscale will occur and B5: Input error (underscale) of status flag 1 will be set to "1: Error". However, control continues during underscale.

Refer to the relationship between sensor error, overscale, underscale, and control (Fig. 15.4.9-1). (P.15-30)

For thermocouple input (no decimal point)

Input range low limit - 50°C (90°F) to Rated low limit

For thermocouple input (with decimal point) and RTD input

Input range low limit - (Input span × 1%) °C (°F) to Rated low limit

For direct current input and DC voltage input

Scaling low limit - Scaling width × 10% to Scaling low limit

15.4.9 Sensor Error

In the case of the following, a sensor error will occur, B5: sensor error of status flag 2 will be set to "1: error", and the control output will be turned off.

Sensor error condition for thermocouple input (no decimal point)

When the input range low limit is less than -50°C (90°F) and exceeds the input range high limit +50°C (90°F)

At this time, PV is fixed to the of input range low limit -50°C (90°F)-1 digit and the input range high limit +50°C (90°F)+1 digit.

Sensor error condition for thermocouple input (with decimal point) and RTD input

When the input range low limit is less than -50°C (90°F) and exceeds the input range high limit +50°C (90°F)

At this time, PV is fixed to the of input range low limit -50°C (90°F)-1 digit and the input range high limit +50°C (90°F)+1 digit.

Sensor error condition for direct current input and DC voltage input

When 4 to 20 mA DC and 1 to 5 V DC

Scaling low limit – Scaling width × 10% or less

At this time, PV is fixed to Scaling lower limit - Scaling width × 10%-1 digit.

When 0 to 1 V DC

Scaling high limit + Scaling width × 10% or more

At this time, PV is fixed Scaling high limit + scaling width × 10% + 1 digit.

When 0 to 20 mA DC, 0 to 5 V DC and 0 to 10 V DC

Value at 0 mA DC or 0 V DC input

Relationship between sensor error, overscale, underscale, and control

For input K: -200 to 1370°C

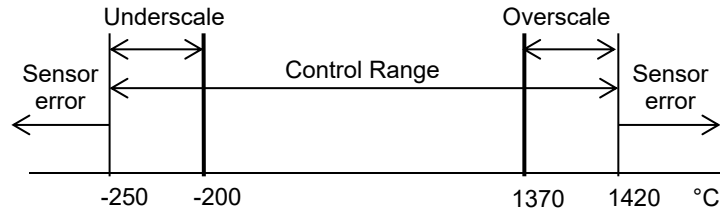

Control output	OFF	ON			OFF
B4 of status flag 1	0	0	0	1	0
B5 of status flag 1	0	1	0	0	0
B5 of status flag 2	1	0	0	0	1

(Fig. 15.4.9-1)

15.4.10 Cold Junction Error

If the internal cold junction temperature is less than -10°C (14°F) or more than 50°C (122°F), a cold junction error will occur and B4: Cold junction error of status flag 2 will be "1: Error". Set. (Valid only for channels for which thermocouple input is selected)

15.4.11 ADC Error

If there is an abnormality such as a failure in the internal circuit, an ADC error occurs, B6: ADC error of status flag 2 is set to "1: Error", and the control output of the channel in which the error occurred is turned off.

At this time, PV becomes 32767.

15.4.12 Warm-up indication

The power indicator flashes every 500 ms for about 3 seconds after the power is turned on.

15.4.13 Contact Switching Total Number of Times

The control output ON/OFF count can be integrated and measured.

ON/OFF is set as one time and totaling is performed.

This allows you to grasp the approximate contact life as the number of switching times of the switch used externally. However, since the saving cycle is 1 hour, the number of times within 1 hour may not be saved due to a power failure.

15.4.14 Total Energizing Time

It can check the time that the power is on.

The accumulated time is saved every 10 minutes.

It can grasp the approximate usage time from the accumulated time. However, since the save cycle is 10 minutes, the time within 10 minutes may not be saved due to a power failure.

Total energizing time: 10 minutes/count

15.4.15 Heater Accumulated Energizing Time

For relay contact output or non-contact voltage output, you can check the cumulative time the heater is energized.

When the output time to the heater reaches 1 minute cumulatively, the count is added.

The accumulated time is saved every 10 minutes.

The accumulated time can be used to understand the approximate usage period of the heater, which can be used as a guide for replacing the heater. However, since the save cycle is 10 minutes, the time within 10 minutes may not be saved due to a power failure.

Cumulative heater energization time: 1 minute/count

15.4.16 Error History

When an error occurs, the bit ON/OFF and accumulated energization time are saved for the past 10 times.

Error history exists for each channel, and device common errors are saved in the error history of all channels.

Total energizing time: 1 hour/count

Bit	Error content
B0	Alarm 1 0: Normal 1: Error
B1	Alarm 2 0: Normal 1: Error
B2	Alarm 3 0: Normal 1: Error
B3	Alarm 4 0: Normal 1: Error
B4	Heater burnout alarm 0: Normal 1: Error
B5	Undefined Indefinite
B6	Loop break alarm 0: Normal 1: Error
B7	Sensor error 0: Normal 1: Error
B8	Input error (Overscale) 0: Normal 1: Error
B9	Input error (Underscale) 0: Normal 1: Error
B10	Cold junction error 0: Normal 1: Error
B11	Non-volatile IC memory error 0: Normal 1: Error
B12	ADC error 0: Normal 1: Error
B13	Undefined Indefinite
B14	Undefined Indefinite
B15	Undefined Indefinite

15.5 Operation Diagram

15.5.1 Control Output Operation Diagram

Action	Reverse (Heating) action			Direction (Cooling) action		
Control action						
Relay contact output	 Periodic action according to deviation			 Periodic action according to deviation		
Non-contact voltage output	 Periodic action according to deviation			 Periodic action according to deviation		
DC current output DC voltage output	 Change continuously according to deviation			 Change continuously according to deviation		
Open collector output	 Periodic action according to deviation			 Periodic action according to deviation		
Display (O1) Green						

: Operates ON or OFF.

CH2 control output: ⑮ ⑰, Display O2

CH3 control output: ⑤ ④, Display O3

CH4 control output: ⑩ ⑨, Display O4

15.5.2 Control Output ON/OFF Operation Diagram

Action	Reverse (Heating) action		Direction (Cooling) action	
Control action				
Relay contact output				
Non-contact voltage output				
DC current output DC voltage output				
Open collector output				
Display (O1) Green				

: Operates ON or OFF.

CH2 control output: ⑩ ⑨, Display O2

CH3 control output: ⑤ ④, Display O3

CH4 control output: ⑩ ⑨, Display O4

15.5.3 Alarm Operation Diagram

	High limit alarm	Low limit alarm
Alarm action	<p>Diagram showing alarm action for a high limit alarm. The process value (SV) is shown as a triangle. The alarm is triggered when the process value reaches the + Alarm 1 value. The alarm action is ON (solid line) and OFF (dashed line) with hysteresis. The hysteresis is labeled 'Alarm 1 hysteresis'. The - Alarm 1 value is also indicated.</p>	<p>Diagram showing alarm action for a low limit alarm. The process value (SV) is shown as a triangle. The alarm is triggered when the process value reaches the - Alarm 1 value. The alarm action is ON (solid line) and OFF (dashed line) with hysteresis. The hysteresis is labeled 'Alarm 1 hysteresis'. The + Alarm 1 value is also indicated.</p>
Alarm output	<p>Diagram showing alarm output for a high limit alarm. The +side output is ON (solid black) and the -side output is OFF (white) when the alarm is triggered.</p>	<p>Diagram showing alarm output for a low limit alarm. The +side output is OFF (white) and the -side output is ON (solid black) when the alarm is triggered.</p>
	High/Low limits alarm	High/Low range alarm
Alarm action	<p>Diagram showing alarm action for a high/low limits alarm. The process value (SV) is shown as a triangle. The alarm is triggered when the process value reaches the Alarm 1 value. The alarm action is ON (solid line) and OFF (dashed line) with hysteresis. The hysteresis is labeled 'Alarm 1 hysteresis'.</p>	<p>Diagram showing alarm action for a high/low range alarm. The process value (SV) is shown as a triangle. The alarm is triggered when the process value reaches the Alarm 1 value. The alarm action is ON (solid line) and OFF (dashed line) with hysteresis. The hysteresis is labeled 'Alarm 1 hysteresis'.</p>
Alarm output	<p>Diagram showing alarm output for a high/low limits alarm. The +side output is ON (solid black) and the -side output is OFF (white) when the alarm is triggered.</p>	<p>Diagram showing alarm output for a high/low range alarm. The +side output is OFF (white) and the -side output is ON (solid black) when the alarm is triggered.</p>
	Process High alarm	Process Low alarm
Alarm action	<p>Diagram showing alarm action for a process high alarm. The process value (SV) is shown as a triangle. The alarm is triggered when the process value reaches the Alarm 1 value. The alarm action is ON (solid line) and OFF (dashed line) with hysteresis. The hysteresis is labeled 'Alarm 1 hysteresis'.</p>	<p>Diagram showing alarm action for a process low alarm. The process value (SV) is shown as a triangle. The alarm is triggered when the process value reaches the Alarm 1 value. The alarm action is ON (solid line) and OFF (dashed line) with hysteresis. The hysteresis is labeled 'Alarm 1 hysteresis'.</p>
Alarm output	<p>Diagram showing alarm output for a process high alarm. The +side output is ON (solid black) and the -side output is OFF (white) when the alarm is triggered.</p>	<p>Diagram showing alarm output for a process low alarm. The +side output is OFF (white) and the -side output is ON (solid black) when the alarm is triggered.</p>
	High limit with standby	Low limit with standby
Alarm action	<p>Diagram showing alarm action for a high limit with standby alarm. The process value (SV) is shown as a triangle. The alarm is triggered when the process value reaches the + Alarm 1 value. The alarm action is ON (solid line) and OFF (dashed line) with hysteresis. The hysteresis is labeled 'Alarm 1 hysteresis'. The - Alarm 1 value is also indicated.</p>	<p>Diagram showing alarm action for a low limit with standby alarm. The process value (SV) is shown as a triangle. The alarm is triggered when the process value reaches the - Alarm 1 value. The alarm action is ON (solid line) and OFF (dashed line) with hysteresis. The hysteresis is labeled 'Alarm 1 hysteresis'. The + Alarm 1 value is also indicated.</p>
Alarm output	<p>Diagram showing alarm output for a high limit with standby alarm. The +side output is ON (solid black) and the -side output is OFF (white) when the alarm is triggered.</p>	<p>Diagram showing alarm output for a low limit with standby alarm. The +side output is OFF (white) and the -side output is ON (solid black) when the alarm is triggered.</p>

	High/Low limits alarm with standby	High/Low limits alarm individually
Alarm action		
Alarm output		
	High/Low limits range alarm individually	High/Low limits alarm with standby individually
Alarm action		
Alarm output		

- : Event output ON.
- : Event output ON or OFF.
- : Event output OFF.
- : The standby function works in this part.

- Alarm 1 value, Alarm 1 high limit value, Alarm 1 low limit value and Alarm 1 hysteresis represent Alarm 1 value setting, Alarm 1 high limit value setting, Alarm 1 low limit value setting and Alarm 1 hysteresis setting, respectively.
In the case of Alarm 2, Alarm 3 and Alarm 4, replace them respectively.
- The EVT indicator lights when the alarm output is ON and turns off when the alarm output is OFF.
- Event output works on the channel for which event output is selected in Event output allocation selection.

15.5.4 Heater Burnout Alarm Operation Diagram

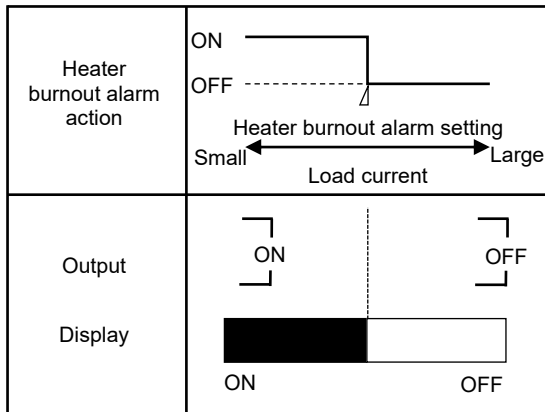

- The EVT indicator lights when the alarm output is ON and turns off when the alarm output is OFF.
- Event output works on the channel for which event output is selected in Event output allocation selection.

15.5.5 Heating/Cooling Control Operation Diagram

When heating/cooling control is selected for CH1 in control function selection

Control action			
Relay contact output (OUT1)	<p>Periodic action according to deviation</p>		
Non-contact voltage output (OUT1)	<p>Periodic action according to deviation</p>		
DC current output (OUT1) DC voltage output (OUT1)	<p>Change continuously according to deviation</p>		
Open collector output (OUT1)	<p>Periodic action according to deviation</p>		
Relay contact output (OUT2)	<p>Periodic action according to deviation</p>		
Non-contact voltage output (OUT2)	<p>Periodic action according to deviation</p>		
DC current output (OUT2) DC voltage output (OUT2)	<p>Change continuously according to deviation</p>		
Open collector output (OUT2)	<p>Periodic action according to deviation</p>		
Display (O1)	<p>ON OFF</p>		
Display (O2)	<p>OFF ON</p>		

: ON or OFF

———— : Heating control action

----- : Cooling control action

When heating/cooling control is selected for CH3 in control function selection

CH3 control output (OUT1): ⑤ ④, Display O3

CH4 control output (OUT2): ⑩ ⑨, Display O4

15.5.6 Heating/Cooling Control Operation Diagram (When Setting Dead Band)

When heating/cooling control is selected for CH1 in control function selection

Control action			
Relay contact output (OUT1)	<p>Periodic action according to deviation</p>		
Non-contact voltage output (OUT1)	<p>Periodic action according to deviation</p>		
DC current output (OUT1) DC voltage output (OUT1)	<p>Change continuously according to deviation</p>		
Open collector output (OUT1)	<p>Periodic action according to deviation</p>		
Relay contact output (OUT2)	<p>Periodic action according to deviation</p>		
Non-contact voltage output (OUT2)	<p>Periodic action according to deviation</p>		
DC current output (OUT2) DC voltage output (OUT2)	<p>Change continuously according to deviation</p>		
Open collector output (OUT2)	<p>Periodic action according to deviation</p>		
Display (O1)	<p>ON OFF</p>		
Display (O2)	<p>OFF ON</p>		



: ON or OFF

— : Heating control action

- - - - : Cooling control action

When heating/cooling control is selected for CH3 in control function selection

CH3 control output (OUT1): ⑤ ④, Display O3

CH4 control output (OUT2): ⑩ ⑨, Display O4

15.5.7 Heating/Cooling Control Operation Diagram (When Setting Overlap Band)

When heating/cooling control is selected for CH1 in control function selection

Control action			
Relay contact output (OUT1)	<p>Periodic action according to deviation</p>		
Non-contact voltage output (OUT1)	<p>Periodic action according to deviation</p>		
DC current output (OUT1) DC voltage output (OUT1)	<p>Change continuously according to deviation</p>		
Open collector output (OUT1)	<p>Periodic action according to deviation</p>		
Relay contact output (OUT2)	<p>Periodic action according to deviation</p>		
Non-contact voltage output (OUT2)	<p>Periodic action according to deviation</p>		
DC current output (OUT2) DC voltage output (OUT2)	<p>Change continuously according to deviation</p>		
Open collector output (OUT2)	<p>Periodic action according to deviation</p>		
Display (O1)			
Display (O2)			

*1: Heating proportional band
*2: Cooling proportional band
*3: Overlap

: ON or OFF

———— : Heating control action

----- : Cooling control action

When heating/cooling control is selected for CH3 in control function selection

CH3 control output (OUT1): ⑤ ④, Display O3

CH4 control output (OUT2): ⑩ ⑨, Display O4

16 Maintenance and Inspection

16.1 Maintenance

You can use the console software (SWC-QTC101M) to check the error history, cumulative number of contact switching operations, heater cumulative energization time, and so on.

Useful for failure prediction maintenance.

Error history

Click [Error history] of [Main screen] tab → [Error history].

Display the Error history screen.

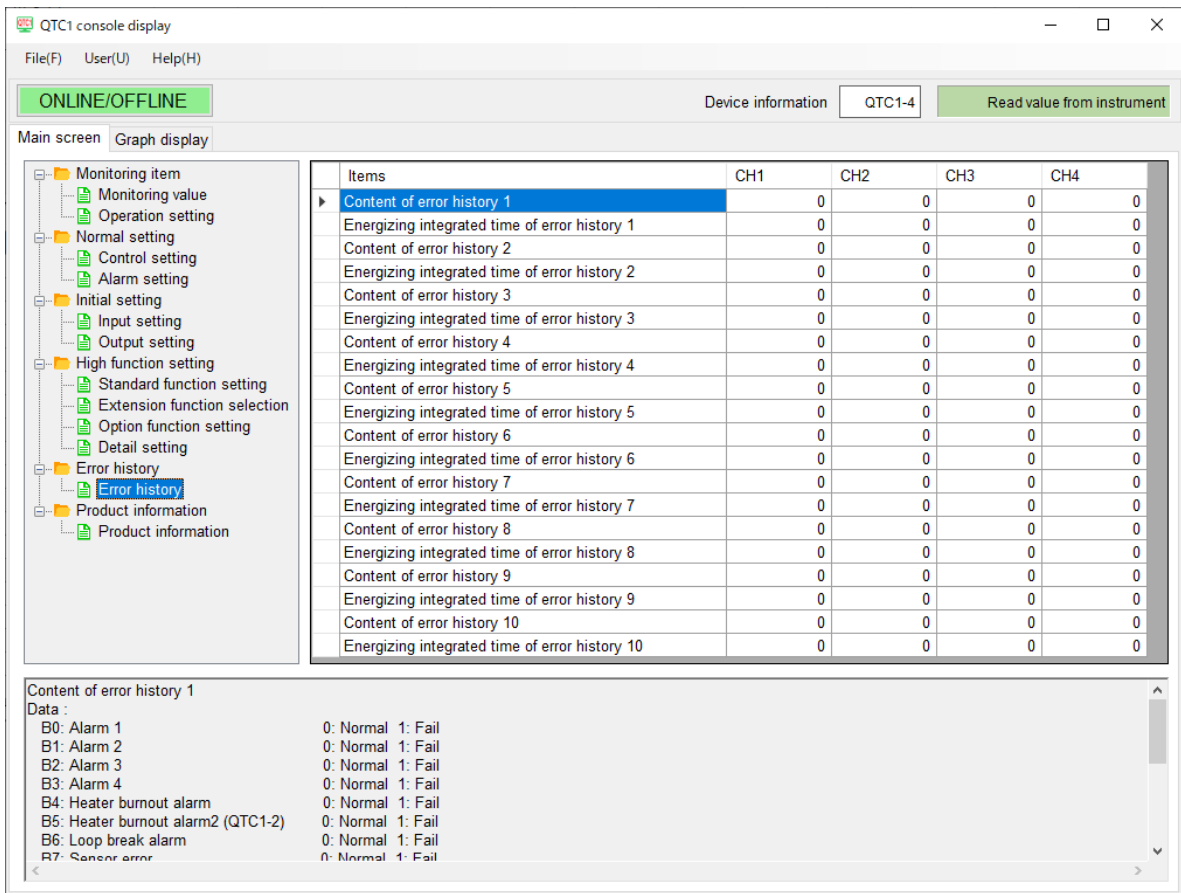

(Fig. 16.1-1)

Content of error history1 to 10, Energizing integrated time of error history1 to 10

The types of error history for the last 10 times and the integrated energizing time when an error occurs are displayed.

It can be used for future predictions from past error history.

Types of error history

The types of error history are shown below.

Bit	Error history types and data	
B0	Alarm 1	0: Normal 1: Error
B1	Alarm 2	0: Normal 1: Error
B2	Alarm 3	0: Normal 1: Error
B3	Alarm 4	0: Normal 1: Error
B4	Heater burnout alarm	0: Normal 1: Error
B5	Undefined	Indefinite
B6	Loop break alarm	0: Normal 1: Error
B7	Sensor error	0: Normal 1: Error
B8	Input error (Overscale)	0: Normal 1: Error
B9	Input error (Underscale)	0: Normal 1: Error
B10	Cold junction error	0: Normal 1: Error
B11	Non-volatile IC memory error	0: Normal 1: Error
B12	ADC error	
B13	Undefined	Indefinite
B14	Undefined	Indefinite
b15	Undefined	Indefinite

Error history display

Error history is updated each time an error occurs. Error history 1 is always the latest.

After the 11th time, delete the old Error history.

Example: Error history 1 is deleted the 11th time and Error history 2 is deleted the 12th time.

Number of error Error history	1st	2nd	3rd		8th	9th	10th	11th	12th
Error history 1	1st	2nd	3rd		8th	9th	10th	11th	12th
Error history 2		1st	2nd		7th	8th	9th	10th	11th
Error history 3			1st		6th	7th	8th	9th	10th
Error history 4					5th	6th	7th	8th	9th
Error history 5					4th	5th	6th	7th	8th
Error history 6					3rd	4th	5th	6th	7th
Error history 7					2nd	3rd	4th	5th	6th
Error history 8					1st	2nd	3rd	4th	5th
Error history 9						1st	2nd	3rd	4th
Error history 10							1st	2nd	3rd
Delete error history								1st	2nd

Contact switching total number of times · Integral electrification time · Heater accumulated energizing time

Click [Product information] of [Main screen] tab → [Product information].

Display the Product information screen.

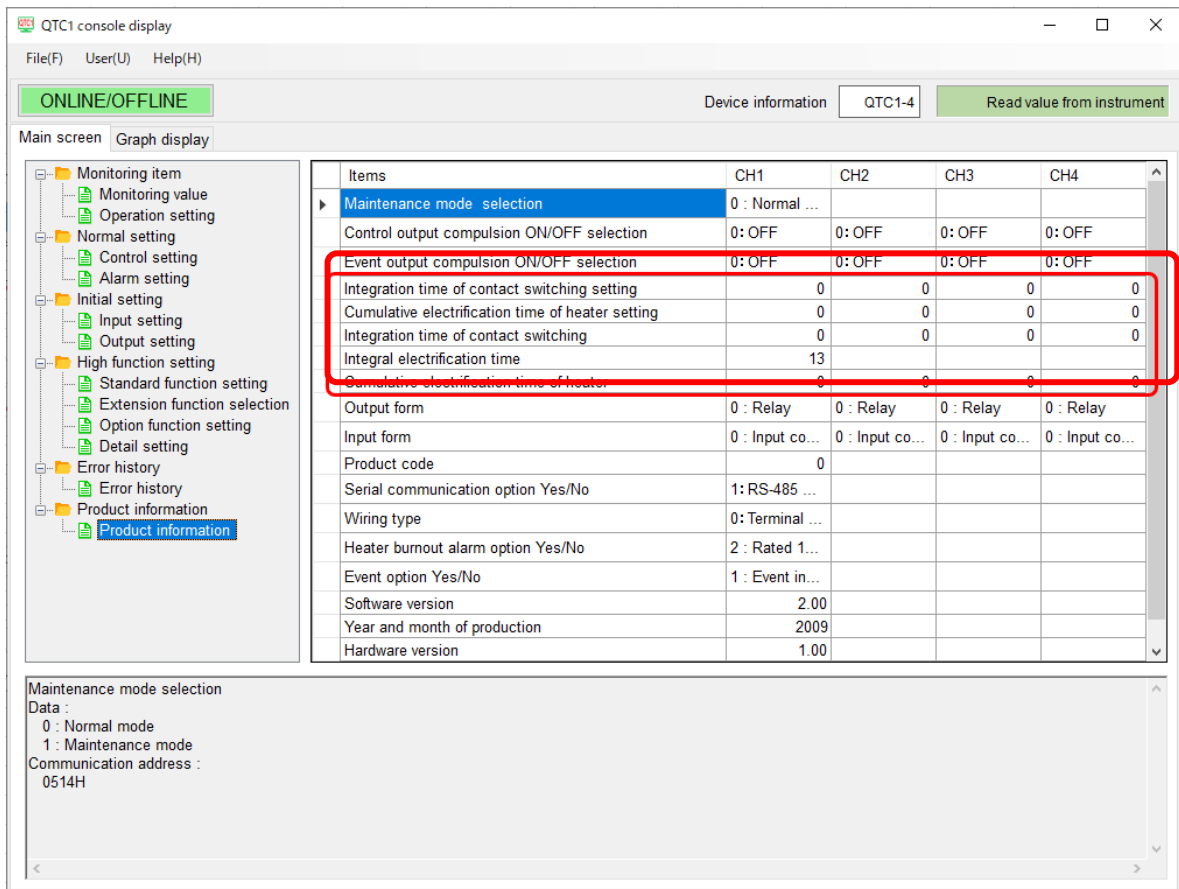

(Fig. 16.1-2)

Contact switching total number of times setting

Set when replacing the control module or relay.

Heater accumulated energizing time setting

Set when replacing the control module or heater.

Contact switching total number of times

It can be used to check the guideline for relay replacement time.

Integral electrification time

It can be used to check the product life of the control module itself.

Heater accumulated energizing time

It can be used to check the guideline of heater product life.

16.2 Inspection

Control output forced ON/OFF and event output forced ON/OFF can be performed by selecting the maintenance mode using the console software (SWC-QTC101M).

Useful for checking wiring.

Control output forced ON/OFF · Event output forced ON/OFF

Click [Product information] of [Main screen] tab → [Product information].

Display the Product information screen.

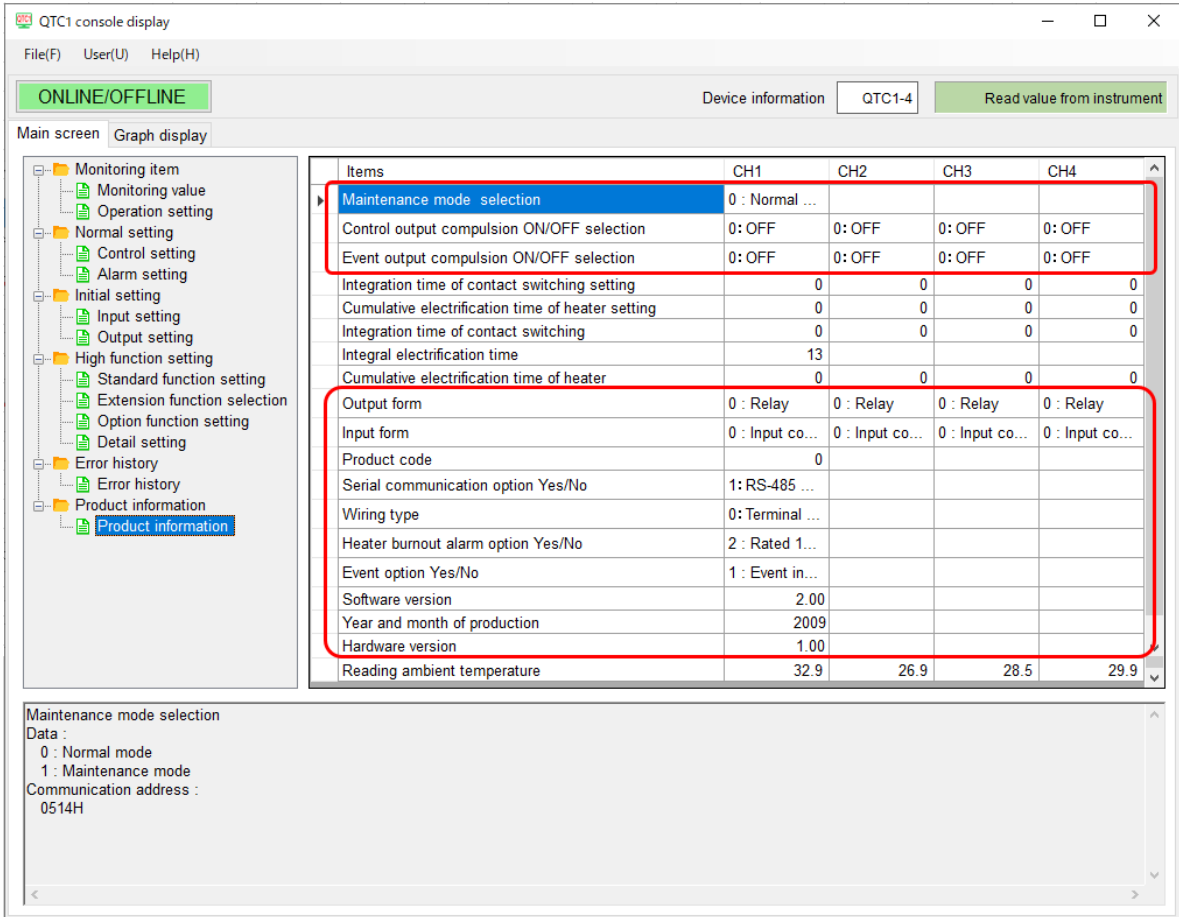

(Fig. 16.2-1)

Maintenance mode selection

Normal mode: Normal control is performed.

Maintenance mode: Only the reading of the input is valid and the control output and event output are turned off.

Control output forced ON/OFF selection

Control output is forcibly turned ON/OFF. It can be used to check the wiring in the operating state.

Event output forced ON/OFF selection

Event output is forcibly turned ON/OFF. It can be used to check the wiring in the operating state.

Product information

It can check the product information from the output form, input form, and product code.

Item	Product information example
Product code	Product code
Power supply / Serial communication option	1: With power supply / host communication function
Wiring type	0: Terminal type
Output form	1: Non-contact voltage (for SSR drive) output
Input form	0: Input code M
Heater burout alarm option	1: CT 4 points Rated 20 A
Event option	1: Event input (4 points)
Software version	Ver. 1.05
Year and month of production	2009: September 2020
Hardware version	Ver. 1.00

17 Specifications

17.1 Standard Specifications

Rating

Rated scale	Input Range		Resolution
	Input		
	K	-200 to 1370°C -328 to 2498°F	1°C (°F)
	K	-200.0 to 400.0°C -328.0 to 752.0°F	0.1°C (°F)
	J	-200 to 1000°C -328 to 1832°F	1°C (°F)
	R	0 to 1760°C 32 to 3200°F	1°C (°F)
	S	0 to 1760°C 32 to 3200°F	1°C (°F)
	B	0 to 1820°C 32 to 3308°F	1°C (°F)
	E	-200 to 800°C -328 to 1472°F	1°C (°F)
	T	-200.0 to 400.0°C -328.0 to 752.0°F	0.1°C (°F)
	N	-200 to 1300°C -328 to 2372°F	1°C (°F)
	PL-II	0 to 1390°C 32 to 2534°F	1°C (°F)
	C(W/Re5-26)	0 to 2315°C 32 to 4199°F	1°C (°F)
	Pt100	-200.0 to 850.0°C -328.0 to 1562.0°F	0.1°C (°F)
	0 to 1 V DC	-32768 to 32767	1
	4 to 20 mA DC	-32768 to 32767	1
	0 to 20 mA DC	-32768 to 32767	1
	0 to 5 V DC	-32768 to 32767	1
	1 to 5 V DC	-32768 to 32767	1
	0 to 10 V DC	-32768 to 32767	1

Scaling possible. However, in the case of thermocouple input and RTD input, it works as SV low limit to SV high limit.

When the scaling high limit and scaling low limit are set to the same value, the control output turns OFF.

Input

Input	Thermocouple input	K, J, R, S, B, E, T, N, C (W/Re5-26) (JIS C1602-2015) PL-II (ASTM E1751M-15) External resistance: 100 Ω or less (B 40 Ω or less)
	RTD input	Pt100 3-wire type (JIS C1604-2013) Allowable input lead wire resistance: 10 Ω or less per wire
	Direct current input	0 to 20 mA DC, 4 to 20 mA DC Input impedance: 50 Ω Allowable input current: 50 mA or less
	DC voltage input	0 to 1 V DC Input impedance: 1 MΩ or more Allowable input voltage: 5 V DC or less Allowable signal source resistance: 2 kΩ or less
		0 to 5 V DC, 1 to 5 V DC, 0 to 10 V DC Input impedance: 100 kΩ or more Allowable input voltage: 15 V DC or less Allowable signal source resistance: 100 Ω or less
Event input	Input points	4 points
	Input type	Voltage contact input sink type
	Circuit current when closed	Approx. 6 mA
	Reading judgment time	40 ms to 40 ms + within the range of input sampling cycle
CT input	20 A specification (-2)	Rated voltage 0.9 V, rated current 30 mA
	100 A specification (-A)	Rated voltage 0.9 V, rated current 120 mA

Output

Control output	Relay contact output	1a Control capacity: 3 A 250 V AC (resistive load) 1 A 250 V AC (inductive load $\cos\phi = 0.4$) Electrical life: 100,000 cycles Minimum applicable load: 10 mA 5 V DC
	Non-contact voltage (for SSR drive) output	12 V DC $\pm 15\%$ Max. 40 mA (short circuit protected) Non-isolated between power supply and output
	DC current output	4 to 20 mA DC, 0 to 20 mA DC Resolution: 12000 Resolution Load resistance: Max. 550 Ω Non-isolated between power supply and output
	DC voltage output	0 to 1 V DC, 0 to 5 V DC, 1 to 5 V DC, 0 to 10 V DC Resolution: 12000 Allowable load resistance: 1 k Ω or more Non-isolated between power supply and output
	Open collector output	NPN Allowable load current: 100 mA or less Load voltage: 30 V DC or less
Event output	Output points	4 points
	Circuit	NPN open collector
	Max. load voltage	30 V DC
	Max. load capacity	50 mA

Power supply

Power supply voltage	24 V DC Allowable voltage fluctuation: 20 to 28 V DC
Power consumption	5 W or less
Inrush current	Max. 10 A

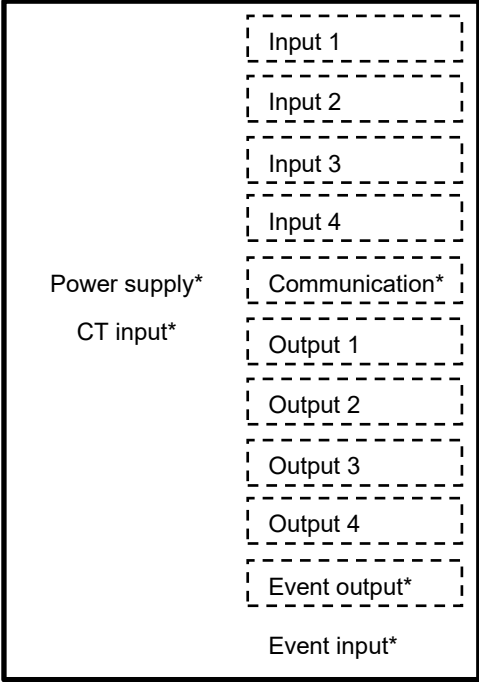
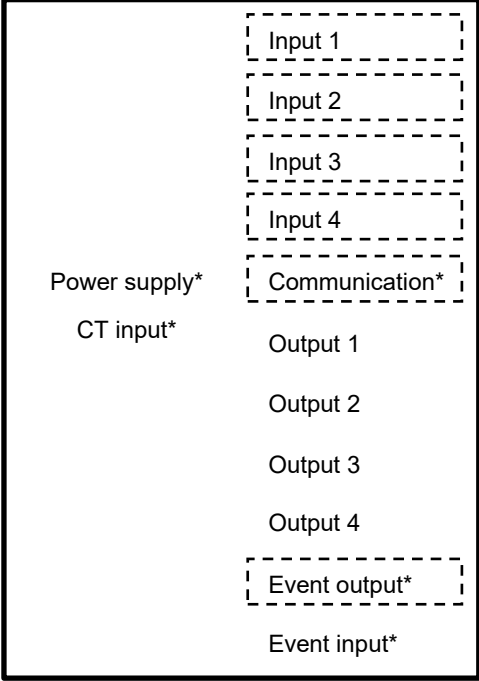
Circuit insulation configuration	<p>Relay contact output, Open collector output</p>  <p>(Fig. 17.1-1)</p> <p>Non-contact voltage output, DC current output, DC voltage output</p>  <p>(Fig. 17.1-2)</p>
Insulation resistance	500 V DC 10 MΩ or more
Dielectric strength	<p>Between Power terminal – Ground (GND): 1.5 kV AC for 1 minute</p> <p>Between Power terminal – Ground (GND): 1.5 kV AC for 1 minute</p> <p>Between Input terminal – Power terminal: 750 V AC for 1 minute</p>

Recommended Environment

Ambient temperature	-10 to 50°C (no condensation or freezing)
Ambient humidity	35 to 85%RH (no condensation)
Altitude	2,000 m or less
Installation environment	Pollution degree 2 (EN61010-1)
Memory protection	Non-volatile IC memory (Number of writes: 1 trillion times)
Environmental specification	RoHS directive compliant

Performance

Base accuracy	When the ambient temperature is 23°C and the mounting angle is ±5 degrees	
	Thermocouple input	Within ±0.2% of each input span Within 0°C, within ±0.4% of each input span R, S input, 0 to 200°C (32 to 392°F): Within ±6°C (12°F) B input, 0 to 300°C (32 to 572°F): Accuracy is not guaranteed.
	RTD input	Within ±0.1% of each input span
	Direct current input DC voltage input	Within ±0.2% of each input span
Cold junction compensation accuracy	Within ±1°C at -10 to 50°C	
Effect of ambient temperature	Thermocouple input	Within ±100 ppm/°C of each input span Less than 0°C (32°F): Within ±200 ppm/°C of each input span
	RTD input	Within ±200 ppm/°C of each input span Less than 0°C (32°F): Within ±400 ppm/°C of each input span
	Direct current input DC voltage input	Within ±100 ppm/°C of each input span
Effect of electromagnetic interference	Within ±1% of each input span	
Input sampling period	20 ms (only direct current input and DC voltage input are valid) 50 ms (only direct current input and DC voltage input are valid) 125 ms For thermocouple input and RTD input, fixed to 125 ms	

General Structure

Weight	Approx. 170 g					
External dimensions	30 × 100 × 85 mm (W × H × D excluding protrusion) 95 mm depth when the terminal cover is attached					
Mounting type	DIN rail mounting type					
Case	Flame-resistant resin, Color: Black					
Panel	Polycarbonate sheet					
Applicable standard	<table border="1"> <tr> <td>EN</td> <td>EN61010-1 (Pollution degree 2)</td> </tr> <tr> <td>EC Directive</td> <td>EMI: EN61326 Radiated interference field strength: EN55011 Group1 ClassA Terminal noise voltage: EN55011 Group1 ClassA EMS: EN61326</td> </tr> </table>		EN	EN61010-1 (Pollution degree 2)	EC Directive	EMI: EN61326 Radiated interference field strength: EN55011 Group1 ClassA Terminal noise voltage: EN55011 Group1 ClassA EMS: EN61326
EN	EN61010-1 (Pollution degree 2)					
EC Directive	EMI: EN61326 Radiated interference field strength: EN55011 Group1 ClassA Terminal noise voltage: EN55011 Group1 ClassA EMS: EN61326					

Setting Structure

Communication specification selection	Select the communication speed, data bit, parity, stop bit, and communication protocol using the DIP switch.
Module address selection	Select the module address 0 to F (1 to 16) with the rotary switch. The value obtained by adding 1 to the value of the selected rotary switch becomes the module address.
CUnet communication specification selection	The station address, communication speed, master address and number of occupied (OWN) items are selected by DIP switches.

Control Performance

Control action selection	<p>Select any control method from 2 DOF PID control, Fast-PID control, Slow-PID control, ON-OFF control or Gap-PID control.</p> <p>Optimal control is possible by selecting the control type according to the intended use and process.</p> <p>The control action selection can be selected only when control prohibited.</p> <p>When the integral time is set to 0 or 0.0, Slow-PID control cannot be selected.</p>																	
2 DOF PID control	<p>Control type that achieves both tracking characteristics when changing SV and suppression of disturbance.</p> <table border="1" data-bbox="512 546 1461 1514"> <tr> <td data-bbox="512 546 778 707">Proportional band (P)</td> <td data-bbox="778 546 1461 707">1 to Input span °C (°F) or 0.1 to Input span °C (°F) when direct current and DC voltage input 0.10 to 100.00% or 0.1 to 1000.0%</td> </tr> <tr> <td data-bbox="512 707 778 869">Integral time (I)</td> <td data-bbox="778 707 1461 869">0 to 3600 seconds or 0.0 to 2000.0 seconds The setting range varies depending on the integral/derivative decimal point position selection.</td> </tr> <tr> <td data-bbox="512 869 778 1030">Derivative time (D)</td> <td data-bbox="778 869 1461 1030">0 to 3600 seconds or 0.0 to 2000.0 seconds The setting range varies depending on the integral/derivative decimal point position selection.</td> </tr> <tr> <td data-bbox="512 1030 778 1128">Proportional gain 2 DOF coefficient (α)</td> <td data-bbox="778 1030 1461 1128">0.00 to 1.00</td> </tr> <tr> <td data-bbox="512 1128 778 1227">Integral 2 DOF coefficient (β)</td> <td data-bbox="778 1128 1461 1227">0.00 to 10.00</td> </tr> <tr> <td data-bbox="512 1227 778 1326">Derivative 2 DOF coefficient (γ, Cd)</td> <td data-bbox="778 1227 1461 1326">0.00 to 1.00</td> </tr> <tr> <td data-bbox="512 1326 778 1370">Proportional cycle</td> <td data-bbox="778 1326 1461 1370">0.1 to 100.0 seconds</td> </tr> <tr> <td data-bbox="512 1370 778 1514">Output high limit, Output low limit</td> <td data-bbox="778 1370 1461 1514">0.0 to 100.0% when DC current output -5.0 to 105.0%</td> </tr> </table>		Proportional band (P)	1 to Input span °C (°F) or 0.1 to Input span °C (°F) when direct current and DC voltage input 0.10 to 100.00% or 0.1 to 1000.0%	Integral time (I)	0 to 3600 seconds or 0.0 to 2000.0 seconds The setting range varies depending on the integral/derivative decimal point position selection.	Derivative time (D)	0 to 3600 seconds or 0.0 to 2000.0 seconds The setting range varies depending on the integral/derivative decimal point position selection.	Proportional gain 2 DOF coefficient (α)	0.00 to 1.00	Integral 2 DOF coefficient (β)	0.00 to 10.00	Derivative 2 DOF coefficient (γ , Cd)	0.00 to 1.00	Proportional cycle	0.1 to 100.0 seconds	Output high limit, Output low limit	0.0 to 100.0% when DC current output -5.0 to 105.0%
Proportional band (P)	1 to Input span °C (°F) or 0.1 to Input span °C (°F) when direct current and DC voltage input 0.10 to 100.00% or 0.1 to 1000.0%																	
Integral time (I)	0 to 3600 seconds or 0.0 to 2000.0 seconds The setting range varies depending on the integral/derivative decimal point position selection.																	
Derivative time (D)	0 to 3600 seconds or 0.0 to 2000.0 seconds The setting range varies depending on the integral/derivative decimal point position selection.																	
Proportional gain 2 DOF coefficient (α)	0.00 to 1.00																	
Integral 2 DOF coefficient (β)	0.00 to 10.00																	
Derivative 2 DOF coefficient (γ , Cd)	0.00 to 1.00																	
Proportional cycle	0.1 to 100.0 seconds																	
Output high limit, Output low limit	0.0 to 100.0% when DC current output -5.0 to 105.0%																	

Fast-PID control	<p>Derivative leading PID control type, a general control type in which the derivative operation operates according to the PV change amount</p> <ul style="list-style-type: none"> • P control: When the integral time and derivative time are set to 0 • PI control: When the derivative time is set to 0 • PD control: When the integral time is set to 0 • Deviation PID control: When changing the SV with time, setting the Proportional gain 2 DOF coefficient (α) to 1.00 and the Derivative 2 DOF coefficient (γ, Cd) to 1.00 causes the differential action to operate according to the deviation. <table border="1" data-bbox="512 546 1461 1610"> <tr> <td data-bbox="512 546 778 736">Proportional band (P)</td> <td data-bbox="778 546 1461 736">1 to Input span °C (°F) or 0.1 to Input span °C (°F) when direct current and DC voltage input 0.10 to 100.00% or 0.1 to 1000.0%</td> </tr> <tr> <td data-bbox="512 736 778 927">Integral time (I)</td> <td data-bbox="778 736 1461 927">0 to 3600 seconds or 0.0 to 2000.0 seconds The setting range varies depending on the integral/derivative decimal point position selection.</td> </tr> <tr> <td data-bbox="512 927 778 1120">Derivative time (D)</td> <td data-bbox="778 927 1461 1120">0 to 3600 seconds or 0.0 to 2000.0 seconds The setting range varies depending on the integral/derivative decimal point position selection.</td> </tr> <tr> <td data-bbox="512 1120 778 1220">Proportional gain 2 DOF coefficient (α)</td> <td data-bbox="778 1120 1461 1220">0.00 to 1.00</td> </tr> <tr> <td data-bbox="512 1220 778 1319">Integral 2 DOF coefficient (β)</td> <td data-bbox="778 1220 1461 1319">0.00 to 10.00</td> </tr> <tr> <td data-bbox="512 1319 778 1420">Derivative 2 DOF coefficient (γ, Cd)</td> <td data-bbox="778 1319 1461 1420">0.00 to 1.00</td> </tr> <tr> <td data-bbox="512 1420 778 1462">Proportional cycle</td> <td data-bbox="778 1420 1461 1462">0.1 to 100.0 seconds</td> </tr> <tr> <td data-bbox="512 1462 778 1610">Output high limit, Output low limit</td> <td data-bbox="778 1462 1461 1610">0.0 to 100.0% when DC current output -5.0 to 105.0%</td> </tr> </table>	Proportional band (P)	1 to Input span °C (°F) or 0.1 to Input span °C (°F) when direct current and DC voltage input 0.10 to 100.00% or 0.1 to 1000.0%	Integral time (I)	0 to 3600 seconds or 0.0 to 2000.0 seconds The setting range varies depending on the integral/derivative decimal point position selection.	Derivative time (D)	0 to 3600 seconds or 0.0 to 2000.0 seconds The setting range varies depending on the integral/derivative decimal point position selection.	Proportional gain 2 DOF coefficient (α)	0.00 to 1.00	Integral 2 DOF coefficient (β)	0.00 to 10.00	Derivative 2 DOF coefficient (γ , Cd)	0.00 to 1.00	Proportional cycle	0.1 to 100.0 seconds	Output high limit, Output low limit	0.0 to 100.0% when DC current output -5.0 to 105.0%
Proportional band (P)	1 to Input span °C (°F) or 0.1 to Input span °C (°F) when direct current and DC voltage input 0.10 to 100.00% or 0.1 to 1000.0%																
Integral time (I)	0 to 3600 seconds or 0.0 to 2000.0 seconds The setting range varies depending on the integral/derivative decimal point position selection.																
Derivative time (D)	0 to 3600 seconds or 0.0 to 2000.0 seconds The setting range varies depending on the integral/derivative decimal point position selection.																
Proportional gain 2 DOF coefficient (α)	0.00 to 1.00																
Integral 2 DOF coefficient (β)	0.00 to 10.00																
Derivative 2 DOF coefficient (γ , Cd)	0.00 to 1.00																
Proportional cycle	0.1 to 100.0 seconds																
Output high limit, Output low limit	0.0 to 100.0% when DC current output -5.0 to 105.0%																

Slow-PID control	<p>Proportional derivative PID control type, in which proportional operation operates according to PV and derivative operation operates according to PV change amount</p> <table border="1" data-bbox="512 259 1461 1261"> <tr> <td data-bbox="512 259 778 421">Proportional band (P)</td> <td data-bbox="788 259 1461 421">1 to Input span °C (°F) or 0.1 to Input span °C (°F) when direct current and DC voltage input 0.10 to 100.00% or 0.1 to 1000.0%</td> </tr> <tr> <td data-bbox="512 421 778 600">Integral time (I)</td> <td data-bbox="788 421 1461 600">0 to 3600 seconds or 0.0 to 2000.0 seconds The setting range varies depending on the integral/derivative decimal point position selection.</td> </tr> <tr> <td data-bbox="512 600 778 779">Derivative time (D)</td> <td data-bbox="788 600 1461 779">0 to 3600 seconds or 0.0 to 2000.0 seconds The setting range varies depending on the integral/derivative decimal point position selection.</td> </tr> <tr> <td data-bbox="512 779 778 869">Proportional gain 2 DOF coefficient (α)</td> <td data-bbox="788 779 1461 869">0.00 to 1.00</td> </tr> <tr> <td data-bbox="512 869 778 969">Integral 2 DOF coefficient (β)</td> <td data-bbox="788 869 1461 969">0.00 to 10.00</td> </tr> <tr> <td data-bbox="512 969 778 1070">Derivative 2 DOF coefficient (γ, Cd)</td> <td data-bbox="788 969 1461 1070">0.00 to 1.00</td> </tr> <tr> <td data-bbox="512 1070 778 1115">Proportional cycle</td> <td data-bbox="788 1070 1461 1115">0.1 to 100.0 seconds</td> </tr> <tr> <td data-bbox="512 1115 778 1261">Output high limit, Output low limit</td> <td data-bbox="788 1115 1461 1261">0.0 to 100.0% when DC current output -5.0 to 105.0%</td> </tr> </table>	Proportional band (P)	1 to Input span °C (°F) or 0.1 to Input span °C (°F) when direct current and DC voltage input 0.10 to 100.00% or 0.1 to 1000.0%	Integral time (I)	0 to 3600 seconds or 0.0 to 2000.0 seconds The setting range varies depending on the integral/derivative decimal point position selection.	Derivative time (D)	0 to 3600 seconds or 0.0 to 2000.0 seconds The setting range varies depending on the integral/derivative decimal point position selection.	Proportional gain 2 DOF coefficient (α)	0.00 to 1.00	Integral 2 DOF coefficient (β)	0.00 to 10.00	Derivative 2 DOF coefficient (γ , Cd)	0.00 to 1.00	Proportional cycle	0.1 to 100.0 seconds	Output high limit, Output low limit	0.0 to 100.0% when DC current output -5.0 to 105.0%
Proportional band (P)	1 to Input span °C (°F) or 0.1 to Input span °C (°F) when direct current and DC voltage input 0.10 to 100.00% or 0.1 to 1000.0%																
Integral time (I)	0 to 3600 seconds or 0.0 to 2000.0 seconds The setting range varies depending on the integral/derivative decimal point position selection.																
Derivative time (D)	0 to 3600 seconds or 0.0 to 2000.0 seconds The setting range varies depending on the integral/derivative decimal point position selection.																
Proportional gain 2 DOF coefficient (α)	0.00 to 1.00																
Integral 2 DOF coefficient (β)	0.00 to 10.00																
Derivative 2 DOF coefficient (γ , Cd)	0.00 to 1.00																
Proportional cycle	0.1 to 100.0 seconds																
Output high limit, Output low limit	0.0 to 100.0% when DC current output -5.0 to 105.0%																
ON-OFF control	<p>Control type that operates with only two values, ON and OFF</p> <table border="1" data-bbox="512 1357 1461 1496"> <tr> <td data-bbox="512 1357 778 1496">ON/OFF hysteresis</td> <td data-bbox="788 1357 1461 1496">0.1 to 1000.0°C (0.1 to 1800.0°F) when direct current and DC voltage input 1 to 10000</td> </tr> </table>	ON/OFF hysteresis	0.1 to 1000.0°C (0.1 to 1800.0°F) when direct current and DC voltage input 1 to 10000														
ON/OFF hysteresis	0.1 to 1000.0°C (0.1 to 1800.0°F) when direct current and DC voltage input 1 to 10000																

<p>Gap-PID control</p>	<p>If the PV is noisy or if the operating part has hysteresis, a slight fluctuation may continue near the deviation of zero.</p> <p>In such a case, the dead zone is normally used, but since control is not performed within the dead zone, PV changes during disturbance.</p> <p>Therefore, it is a control method that gives deviation characteristics within the dead zone and responds to disturbance.</p> <table border="1" data-bbox="512 405 1461 1608"> <tr> <td data-bbox="512 405 778 589">Proportional band(P)</td> <td data-bbox="778 405 1461 589">1 to Input span °C (°F) or 0.1 to Input span °C (°F) when direct current and DC voltage input 0.10 to 100.00% or 0.1 to 1000.0%</td> </tr> <tr> <td data-bbox="512 589 778 779">Integral time (I)</td> <td data-bbox="778 589 1461 779">0 to 3600 seconds or 0.0 to 2000.0 seconds The setting range varies depending on the integral/derivative decimal point position selection.</td> </tr> <tr> <td data-bbox="512 779 778 969">Derivative time (D)</td> <td data-bbox="778 779 1461 969">0 to 3600 seconds or 0.0 to 2000.0 seconds The setting range varies depending on the integral/derivative decimal point position selection.</td> </tr> <tr> <td data-bbox="512 969 778 1070">Proportional gain 2 DOF coefficient (α)</td> <td data-bbox="778 969 1461 1070">0.00 to 1.00</td> </tr> <tr> <td data-bbox="512 1070 778 1171">Integral 2 DOF coefficient (β)</td> <td data-bbox="778 1070 1461 1171">0.00 to 10.00</td> </tr> <tr> <td data-bbox="512 1171 778 1272">Derivative 2 DOF coefficient (γ, Cd)</td> <td data-bbox="778 1171 1461 1272">0.00 to 1.00</td> </tr> <tr> <td data-bbox="512 1272 778 1317">Proportional cycle</td> <td data-bbox="778 1272 1461 1317">0.1 to 100.0 seconds</td> </tr> <tr> <td data-bbox="512 1317 778 1462">Output high limit, Output low limit</td> <td data-bbox="778 1317 1461 1462">0.0 to 100.0% when DC current output -5.0 to 105.0%</td> </tr> <tr> <td data-bbox="512 1462 778 1563">Gap width</td> <td data-bbox="778 1462 1461 1563">0.0 to 10.0% Proportional band × Gap width</td> </tr> <tr> <td data-bbox="512 1563 778 1608">Gap coefficient</td> <td data-bbox="778 1563 1461 1608">0.0 to 1.0</td> </tr> </table>	Proportional band(P)	1 to Input span °C (°F) or 0.1 to Input span °C (°F) when direct current and DC voltage input 0.10 to 100.00% or 0.1 to 1000.0%	Integral time (I)	0 to 3600 seconds or 0.0 to 2000.0 seconds The setting range varies depending on the integral/derivative decimal point position selection.	Derivative time (D)	0 to 3600 seconds or 0.0 to 2000.0 seconds The setting range varies depending on the integral/derivative decimal point position selection.	Proportional gain 2 DOF coefficient (α)	0.00 to 1.00	Integral 2 DOF coefficient (β)	0.00 to 10.00	Derivative 2 DOF coefficient (γ, Cd)	0.00 to 1.00	Proportional cycle	0.1 to 100.0 seconds	Output high limit, Output low limit	0.0 to 100.0% when DC current output -5.0 to 105.0%	Gap width	0.0 to 10.0% Proportional band × Gap width	Gap coefficient	0.0 to 1.0
Proportional band(P)	1 to Input span °C (°F) or 0.1 to Input span °C (°F) when direct current and DC voltage input 0.10 to 100.00% or 0.1 to 1000.0%																				
Integral time (I)	0 to 3600 seconds or 0.0 to 2000.0 seconds The setting range varies depending on the integral/derivative decimal point position selection.																				
Derivative time (D)	0 to 3600 seconds or 0.0 to 2000.0 seconds The setting range varies depending on the integral/derivative decimal point position selection.																				
Proportional gain 2 DOF coefficient (α)	0.00 to 1.00																				
Integral 2 DOF coefficient (β)	0.00 to 10.00																				
Derivative 2 DOF coefficient (γ, Cd)	0.00 to 1.00																				
Proportional cycle	0.1 to 100.0 seconds																				
Output high limit, Output low limit	0.0 to 100.0% when DC current output -5.0 to 105.0%																				
Gap width	0.0 to 10.0% Proportional band × Gap width																				
Gap coefficient	0.0 to 1.0																				
<p>Control range</p>	<p>When the control range below is exceeded, the control output is turned off.</p> <p>Control range for thermocouple input (no decimal point) Input range low limit -50°C (90°F) to Input range high limit +50°C (90°F)</p> <p>Control range for thermocouple input (with decimal point) and RTD input Input range low limit -(Input span × 1 %)°C (°F) to Input range high limit +50.0°C (90.0°F)</p> <p>Control range for direct current and DC voltage input Scaling low limit –Scaling width × 10% to Scaling high limit + Scaling width × 10%</p>																				

Standard Function

<p>Alarm output</p>	<p>When the deviation is set to \pm of SV (excluding the process alarm), the alarm output turns ON or OFF (high/low limit range alarm) when PV exceeds the range. High limit alarm, Low limit alarm, High/Low limits alarm, High/Low limits range, Process High alarm, Process Low alarm, High limit with standby, Low limit with standby, High/Low limits alarm with standby, High/Low limits alarm individually, High/Low limit s range alarm individually, High/Low limits alarm with standby individually, or No action.</p> <p>Refer to “15.5.3 Alarm Operation Diagram (P.15-34, P.15-35)” for detail of alarm action.</p> <table border="1" data-bbox="488 524 1457 1167"> <tr> <td>Action</td> <td>ON/OFF action</td> </tr> <tr> <td>Alarm hysteresis</td> <td>0.1 to 1000.0°C (0.1 to 1800.0°F) when direct current and DC voltage input 1 to 10000</td> </tr> <tr> <td>Output</td> <td>Event output allocated by status flag or event output allocation selection</td> </tr> <tr> <td>Alarm setting 0 Enabled/Disabled selection</td> <td>When Enabled is selected in Alarm setting 0 Enabled/Disabled selection, High limit alarm, Low limit alarm, High/Low limits alarm, High/Low limits range, Process High alarm, Process Low alarm, High limit with standby, Low limit with standby, High/Low limits alarm with standby, High/Low limits alarm individually, High/Low limit s range alarm individually, High/Low limits alarm with standby individually, the alarm action will work even if the alarm action setting value is set to 0.</td> </tr> </table>	Action	ON/OFF action	Alarm hysteresis	0.1 to 1000.0°C (0.1 to 1800.0°F) when direct current and DC voltage input 1 to 10000	Output	Event output allocated by status flag or event output allocation selection	Alarm setting 0 Enabled/Disabled selection	When Enabled is selected in Alarm setting 0 Enabled/Disabled selection, High limit alarm, Low limit alarm, High/Low limits alarm, High/Low limits range, Process High alarm, Process Low alarm, High limit with standby, Low limit with standby, High/Low limits alarm with standby, High/Low limits alarm individually, High/Low limit s range alarm individually, High/Low limits alarm with standby individually, the alarm action will work even if the alarm action setting value is set to 0.
Action	ON/OFF action								
Alarm hysteresis	0.1 to 1000.0°C (0.1 to 1800.0°F) when direct current and DC voltage input 1 to 10000								
Output	Event output allocated by status flag or event output allocation selection								
Alarm setting 0 Enabled/Disabled selection	When Enabled is selected in Alarm setting 0 Enabled/Disabled selection, High limit alarm, Low limit alarm, High/Low limits alarm, High/Low limits range, Process High alarm, Process Low alarm, High limit with standby, Low limit with standby, High/Low limits alarm with standby, High/Low limits alarm individually, High/Low limit s range alarm individually, High/Low limits alarm with standby individually, the alarm action will work even if the alarm action setting value is set to 0.								
<p>Loop break alarm</p>	<p>Detects actuator trouble (heater burnout, sensor burnout).</p> <table border="1" data-bbox="488 1249 1457 1570"> <tr> <td>Loop break alarm time</td> <td>0 to 200 minutes</td> </tr> <tr> <td>Loop break alarm band</td> <td>0 to 150°C (0 to 270°F) or 0.0 to 150.0°C (0.0 to 270.0°F) when direct current and DC voltage input 0 to 1500</td> </tr> <tr> <td>Output</td> <td>Event output allocated by status flag or event output allocation selection</td> </tr> </table>	Loop break alarm time	0 to 200 minutes	Loop break alarm band	0 to 150°C (0 to 270°F) or 0.0 to 150.0°C (0.0 to 270.0°F) when direct current and DC voltage input 0 to 1500	Output	Event output allocated by status flag or event output allocation selection		
Loop break alarm time	0 to 200 minutes								
Loop break alarm band	0 to 150°C (0 to 270°F) or 0.0 to 150.0°C (0.0 to 270.0°F) when direct current and DC voltage input 0 to 1500								
Output	Event output allocated by status flag or event output allocation selection								
<p>Setting value ramp function</p>	<p>When the SV is changed, control is performed from the SV before the change to the SV after the change at the set change rate.</p> <p>When the power is turned on, control is performed at the set rate of change from PV to SV at that time.</p> <table border="1" data-bbox="488 1776 1457 2096"> <tr> <td>SV increase rate</td> <td>0 to 10000 °C/min. (0 to 18000 °F/min.) or 0.0 to 1000.0 °C /min. (0.0 to 1800.0 °F/min.) when direct current and DC voltage input 0 to 10000/min.</td> </tr> <tr> <td>SV decrease rate</td> <td>0 to 10000 °C/min. (0 to 18000 °F/min.) or 0.0 to 1000.0 °C /min. (0.0 to 1800.0 °F/min.) when direct current and DC voltage input 0 to 10000/min.</td> </tr> </table>	SV increase rate	0 to 10000 °C/min. (0 to 18000 °F/min.) or 0.0 to 1000.0 °C /min. (0.0 to 1800.0 °F/min.) when direct current and DC voltage input 0 to 10000/min.	SV decrease rate	0 to 10000 °C/min. (0 to 18000 °F/min.) or 0.0 to 1000.0 °C /min. (0.0 to 1800.0 °F/min.) when direct current and DC voltage input 0 to 10000/min.				
SV increase rate	0 to 10000 °C/min. (0 to 18000 °F/min.) or 0.0 to 1000.0 °C /min. (0.0 to 1800.0 °F/min.) when direct current and DC voltage input 0 to 10000/min.								
SV decrease rate	0 to 10000 °C/min. (0 to 18000 °F/min.) or 0.0 to 1000.0 °C /min. (0.0 to 1800.0 °F/min.) when direct current and DC voltage input 0 to 10000/min.								

Resore action selection when power is turn on	When the power is turned on, select whether to resume in the continuous state (state before turning off the power) or in the stopped state.	
Non-volatile IC memory save selection	Select whether to allow or prohibit saving data to the non-volatile IC memory. If you select save prohibition, can temporarily change all the set values, but if turn the power off and then on, it will return to the value before selecting save prohibition.	
Auto/Manual selection	<p>Select automatic or manual control.</p> <p>When switching from automatic control to manual control or from manual control to automatic control, the balanceless bumpless function works to prevent sudden changes in MV.</p> <p>When switched to manual control, the MV can be set arbitrarily. (*)</p> <p>When the power is turned on again, it is restored with the control action selected in the power-on restore action selection.</p> <p>Manual control MV setting range -5.0 to 105.0%</p> <p>(*): If the sensor error occurs in manual control, the MV becomes 0 %.</p>	
Sensor correction factor setting	<p>Set the slope of the sensor input value.</p> <p>0.000 to 10.000</p>	
Sensor correction setting	<p>Set the sensor correction value.</p> <p>If the temperature at the control location and the temperature at the sensor installation location are different, PV is shifted and corrected. However, it is valid within the input rated range regardless of the sensor correction value.</p> <p>-100.0 to 100.0°C (-180.0 to 180.0°F) when direct current and DC voltage input, -1000 to 1000</p>	
Control function selection	Select from standard, heating/cooling control, cascade control or output selection function.	
Heating/Cooling control	<p>If it is difficult to control the temperature of the controlled object only by heating control, control is performed in combination with cooling control.</p> <p>When heating/cooling control is selected for CH1 in control function selection, CH1 becomes heating output and CH2 becomes cooling output.</p> <p>When heating/cooling control is selected for CH3 in control function selection, CH3 becomes heating output and CH4 becomes cooling output.</p>	
2 DOF PID control	Cooling P-band (Pc)	0 to Input span °C (°F) or 0.0 to Input span °C (°F) when direct current and DC voltage input 0.00 to 100.00% or 0.1 to 1000.0%
	Cooling Integral time (Ic)	0 to 3600 seconds or 0.0 to 2000.0 seconds The setting range varies depending on the integral/derivative decimal point position selection.
	Cooling Derivative time (Dc)	0 to 3600 seconds or 0.0 to 2000.0 seconds The setting range varies depending on the integral/derivative decimal point position selection.
	Cooling proportional cycle	0.1 to 100.0 seconds
	Cooling output high limit, Cooling output low limit	0.0 to 100.0% when DC current output -5.0 to 105.0%

Fast-PID control	Cooling P-band (Pc)	0 to Input span °C (°F) or 0.0 to Input span °C (°F) when direct current and DC voltage input 0.00 to 100.00% or 0.0 to 1000.0%
	Cooling Integral time (Ic)	0 to 3600 seconds or 0.0 to 2000.0 seconds The setting range varies depending on the integral/derivative decimal point position selection.
	Cooling Derivative time (Dc)	0 to 3600 seconds or 0.0 to 2000.0 seconds The setting range varies depending on the integral/derivative decimal point position selection.
	Cooling proportional cycle	0.1 to 100.0 seconds
	Cooling output high limit, Cooling output low limit	0.0 to 100.0% when DC current output -5.0 to 105.0%
Slow-PID control	Cooling P-band (Pc)	0 to Input span °C (°F) or 0.0 to Input span °C (°F) when direct current and DC voltage input 0.00 to 100.00% or 0.0 to 1000.0%
	Cooling Integral time (Ic)	0 to 3600 seconds or 0.0 to 2000.0 seconds The setting range varies depending on the integral/derivative decimal point position selection.
	Cooling Derivative time (Dc)	0 to 3600 seconds or 0.0 to 2000.0 seconds The setting range varies depending on the integral/derivative decimal point position selection.
	Cooling proportional cycle	0.1 to 100.0 seconds
	Cooling output high limit, Cooling output low limit	0.0 to 100.0% when DC current output -5.0 to 105.0%
ON-OFF control	Cooling ON/OFF hysteresis	0.1 to 1000.0°C (0.1 to 1800.0°F) when direct current and DC voltage input 1 to 10000

Cooling control parameters	Overlap/dead band	-100.0 to 100.0°C (-180.0 to 180.0°F) when direct current and DC voltage input -1000 to 1000%
	Cooling action mode selection	Air cooling (Linear characteristics) Oil cooling (1.5th power of the linear characteristics) Water cooling (2nd power of the linear characteristics)
Cascade control	<p>The MV on the master side obtained from the SV on the master side (CH1 or CH3) and PV is substituted for the SV on the slave side (CH2 or CH4), and control calculation is performed on the slave side and control is performed on the MV on the slave side.</p> <p>When cascade control is selected for CH1, CH1 becomes the master and CH2 becomes the slave.</p> <p>When cascade control is selected for CH3, CH3 becomes the master and CH4 becomes the slave.</p>	
Extension function selection	Select No function, Peak power suppression function or Auto balance control function.	
Peak power suppression function	<p>A function to suppress the peak power value when there is a power limit for the facility.</p> <p>By setting the total current, power suppression is controlled when the sum of the current values set for each channel is less than or equal to the total current value. However, this function does not work for DC current output and DC voltage output.</p> <p>The change of each set value is effective only when control is inhibited.</p>	
	Total current setting	0.0 to 400.0 A
	Current value setting	0.0 to 100.0 A (Set by each channel)
	Output ON delay setting	<p>When the peak power suppression function operates and the total current value is exceeded due to mechanical delay even when the value is less than the total current value, the control output is delayed and output.</p> <p>0 to 100 ms</p>
Current judgment	Judges the current value for each proportional cycle of each channel, and judges whether to allow control output, wait for control output, or determine which channel will allow control output in the next proportional cycle.	
Conditions for enabling the peak power suppression function	<p>The peak power suppression function will be enabled in the following cases.</p> <ul style="list-style-type: none"> • When the input is not the input error, overscale or underscale during control prohibition • When Control Enable is selected in Control Enable/Prohibited selection 	
Conditions for disabling the peak power suppression function	<p>The peak power suppression function will be disabled in the following cases.</p> <ul style="list-style-type: none"> • When the input is not the input error, overscale or underscale during control prohibition • When Control Prohibited is selected in Control Enable/Prohibited selection • When ON/OFF control action is selected in Control action selectiton 	
AT when the Peak Power Suppression function is enabled	When the peak power suppression function is enabled, the output is allocated so that it does not exceed the total current setting value, so AT cannot be executed because it may exceed the total current setting value if AT is executed.	

<p>Auto balance control function</p>	<p>This function suppresses partial burning and mechanical strain by performing soaking on one control target at multiple control points.</p> <p>When using the communication expansion module QMC1-C□, QMC1-C□ becomes the master and transfers data between control modules.</p> <p>When the communication expansion module QMC1-C□ is not used, the control module QTC1-4P (with power supply / communication option) becomes the master, and the master channel and slave channel are selected from the master input channel by auto balance control master/slave selection. The auto balance control function does not work when the master channel is not selected.</p> <p>When Enabled is selected for Auto balance control Enabled/Disabled selection, control prohibited is changed to control allowed to start auto balance control.</p> <p>The slave channels that are allowed to control within 10 seconds from the master channel on which autobalance control was started are the target channels for autobalance control.</p> <p>Slave channels that have been allowed to control after 10 seconds have passed (during automatic balance control operation) are excluded from normal operation and are controlled normally.</p> <p>When the auto balance control function operates, the SV of the slave channel heats up according to the PV of the master channel.</p> <p>If the master channel has an input error, cancel the auto balance control function.</p> <p>Slave channels that have no input error are individually controlled normally. The set value ramp function is disabled during auto balance control. It is also invalid when 2 DOF PID control, Fast-PID control, ON-OFF control or Gap-PID control is selected in control action selection.</p> <p>When using the auto balance control function, the same input range is used for the inputs that are used for auto balance control.</p> <p>For direct current input and DC voltage input, set the scaling high limit and scaling low limit to the same setting.</p> <p>Slave channel SV of auto balance control Slave channel SV of auto balance control = Master channel PV + (Slave channel SV - Master channel SV)</p>
<p>Auto balance control interlock/alone selection</p>	<p>Select whether to use the auto balance control function with interlock or alone.</p> <p>When interlock is selected, automatic balance control is possible between modules including the master module. However, only one group can be used with interlock.</p> <p>When alone is selected, auto balance control is possible only within the module.</p>

Auto balance control start output setting	<p>When using the auto balance control function, the target value of the master channel is SV, but since the SV of the slave channel becomes the PV of the master channel, the slave channel does not start the auto balance control unless the master channel heats up.</p> <p>As a result, the temperature rise of the slave channel is delayed, a temperature difference with the master channel is generated, and in order to prevent the simultaneity from being deteriorated, the MV is set so that the output of the slave channel turns on at the start of the auto balance control.</p> <p>0.00 to 1.00 (corresponds to 0 to 100%)</p>
Auto balance control start condition setting	<p>The auto balance control is started in the following cases.</p> <ul style="list-style-type: none"> • When input is not burnout or underscale • When AT Cancel is selected in AT Perform/Cancel • When master is selected in master/slave selection • When Reverse action is selected in Direct/Reverse action selection • When the heater burnout alarm or loop break alarm is not generated
Auto balance control cancel condition setting	<p>The auto balance control is canceled in the following cases.</p> <ul style="list-style-type: none"> • When input is not burnout or underscale • When AT Perform is selected in AT Perform/Cancel • When Direct action is selected in Direct/Reverse action selection • When a Heater burnout alarm or Loop break alarm occurs on the master channel. However, if a Heater burnout alarm or Loop break alarm occurs on a slave channel, the auto balance control is canceled only for that channel. • When Control Prohibited is selected in Control Enable/Prohibited selection
Auto balance control cancel area setting	<p>When the PV of the master channel reaches the autobalance control cancel area and when the PV of each slave channel reaches the autobalance control cancel area, the auto balance control function is released.</p> <p>Master channel $PV \geq \text{Master channel SV} - \text{Auto balance control cancel area}$ (When 0 is set, the auto balance control cancel area is twice the proportional band of the master channel.)</p> <p>Slave channel $PV \geq \text{Slave channel SV} - \text{Auto balance control cancel area}$ (When 0 is set, the auto balance control cancel area is twice the proportional band of the master channel.)</p>
Output selection function	<p>If the used channel fails, you can change the input to an unused channel and select the output location for the input.</p> <p>Select the input channel for the output of each channel.</p> <p>Selection item: CH1 to CH4</p>

<p>Output gain-bias function</p>	<p>When controlling the temperature of a metal plate, heater control is performed at multiple locations. When using multiple outputs for inputs, if the distribution of output amounts is known in advance, the ratio to MV (reference output) And the bias is set to control evenly.</p> <table border="1" data-bbox="488 309 1461 405"> <tr> <td data-bbox="488 309 778 353">Output gain</td> <td data-bbox="778 309 1461 353">0.00 to 10.00 times</td> </tr> <tr> <td data-bbox="488 353 778 405">Output bias</td> <td data-bbox="778 353 1461 405">0.0 to 100.0%</td> </tr> </table>	Output gain	0.00 to 10.00 times	Output bias	0.0 to 100.0%		
Output gain	0.00 to 10.00 times						
Output bias	0.0 to 100.0%						
<p>Input math function</p>	<p>Select Standard, Difference input or Addition input.</p> <p>The input math function selected for CH1 corresponds to CH1 and CH2, and the input math function selected for CH3 corresponds to CH3 and CH4. However, if heating/cooling control, cascade control or output selection function is selected for control function selection, the input math function is invalid.</p> <table border="1" data-bbox="488 741 1461 1850"> <tr> <td data-bbox="488 741 778 792">Standard</td> <td data-bbox="778 741 1461 792">The input value of CH is used as PV for control.</td> </tr> <tr> <td data-bbox="488 792 778 1323">Difference input</td> <td data-bbox="778 792 1461 1323"> <p>The temperature difference between CH1 and CH2 is used as the PV for CH1 and is controlled by CH1. $CH1\ PV = CH1\ PV - CH2\ PV$</p> <p>The temperature difference between CH3 and CH4 is used as the PV for CH3 and is controlled by CH3. $CH3\ PV = CH3\ PV - CH4\ PV$</p> <p>Each setting value such as scaling and PV filter time constant can be set for each channel.</p> <p>When performing AT with the difference input specifications, execute AT individually for each channel and then select difference input.</p> </td> </tr> <tr> <td data-bbox="488 1323 778 1850">Addition input</td> <td data-bbox="778 1323 1461 1850"> <p>The added value of CH1 and CH2 is used as the PV for CH1 and is controlled by CH1. $CH1\ PV = CH1\ PV + CH2\ PV$</p> <p>The added value of CH3 and CH4 is used as the PV for CH3 and is controlled by CH3. $CH3\ PV = CH3\ PV + CH4\ PV$</p> <p>Each setting value such as scaling and PV filter time constant can be set for each channel.</p> <p>When performing AT with the addition input specifications, execute AT individually for each channel and then select addition input.</p> </td> </tr> </table>	Standard	The input value of CH is used as PV for control.	Difference input	<p>The temperature difference between CH1 and CH2 is used as the PV for CH1 and is controlled by CH1. $CH1\ PV = CH1\ PV - CH2\ PV$</p> <p>The temperature difference between CH3 and CH4 is used as the PV for CH3 and is controlled by CH3. $CH3\ PV = CH3\ PV - CH4\ PV$</p> <p>Each setting value such as scaling and PV filter time constant can be set for each channel.</p> <p>When performing AT with the difference input specifications, execute AT individually for each channel and then select difference input.</p>	Addition input	<p>The added value of CH1 and CH2 is used as the PV for CH1 and is controlled by CH1. $CH1\ PV = CH1\ PV + CH2\ PV$</p> <p>The added value of CH3 and CH4 is used as the PV for CH3 and is controlled by CH3. $CH3\ PV = CH3\ PV + CH4\ PV$</p> <p>Each setting value such as scaling and PV filter time constant can be set for each channel.</p> <p>When performing AT with the addition input specifications, execute AT individually for each channel and then select addition input.</p>
Standard	The input value of CH is used as PV for control.						
Difference input	<p>The temperature difference between CH1 and CH2 is used as the PV for CH1 and is controlled by CH1. $CH1\ PV = CH1\ PV - CH2\ PV$</p> <p>The temperature difference between CH3 and CH4 is used as the PV for CH3 and is controlled by CH3. $CH3\ PV = CH3\ PV - CH4\ PV$</p> <p>Each setting value such as scaling and PV filter time constant can be set for each channel.</p> <p>When performing AT with the difference input specifications, execute AT individually for each channel and then select difference input.</p>						
Addition input	<p>The added value of CH1 and CH2 is used as the PV for CH1 and is controlled by CH1. $CH1\ PV = CH1\ PV + CH2\ PV$</p> <p>The added value of CH3 and CH4 is used as the PV for CH3 and is controlled by CH3. $CH3\ PV = CH3\ PV + CH4\ PV$</p> <p>Each setting value such as scaling and PV filter time constant can be set for each channel.</p> <p>When performing AT with the addition input specifications, execute AT individually for each channel and then select addition input.</p>						
<p>Input difference function</p>	<p>The input difference selection detects the input difference between the local channel and the selected channel, and when the input difference setting exceeds the set value, the input difference flag is set to 1. However, this function does not work when you select your own channel with input difference selection.</p>						

Scaling function	The scaling low limit to the scaling high limit can be set arbitrarily within the input range. For thermocouple input and RTD input, this serves as the SV low limit to SV high limit. When the scaling high limit and scaling low limit are set to the same value, the control output turns OFF.
Number of communication management module setting	Set the number of modules managed by the master module when using the SIF function or auto balance control function. 1 to 16 modules

Attached Function

Power failure countermeasure	The setting data is backed up in the non-volatile IC memory.
Self-diagnosis	The watchdog timer monitors runaway and halt of the program, and when an abnormality is detected, it resets the MCU and initializes the instrument.
Automatic cold junction temperature compensation	Detect the temperature of the connection terminal between the thermocouple and the instrument, and make it the same as if the reference contact is always set to 0°C (32°F). (Only valid for channels for which thermocouple input is selected.)
PV filter time constant setting	The fluctuation of PV due to noise is reduced by the digital first-order low-pass filter.
Number of moving average setting	Stabilizes the indicated value by averaging the values that PV changes due to noise.
CH Enable/Disable selection	Select enable or disable for each channel. When disabled is selected, all operations are disabled for the selected channel and PV becomes 0.
Overscale	In the case of the following input range, overscale will occur and B4: Input error (overscale) of status flag 1 will be set to "1: Error". However, control continues during overscale. Refer to the relationship between sensor error, overscale, underscale, and control (Fig. 17.1-3). (P.17-19) For thermocouple input (no decimal point) Rated high limit to Input range high limit 50°C (90°F) For thermocouple input (with decimal point) and RTD input Rated high limit to Input range high limit 50.0°C (90.0°F) For direct current input and DC voltage input Scaling high limit to Scaling high limit Scaling width × 10%
Underscale	In the case of the following input range, underscale will occur and B5: Input error (under scale) of status flag 1 will be set to "1: Error". However, control continues during underscale. Refer to the relationship between sensor error, overscale, underscale, and control (Fig. 17.1-3). (P.17-19) For thermocouple input (no decimal point) Input range low limit 50°C (90°F) to Rated low limit For thermocouple input (with decimal point) and RTD input Input range low limit Input span × 1%°C (°F) to Rated low limit For direct current input and DC voltage input Scaling low limit Scaling width × 10% to Scaling low limit

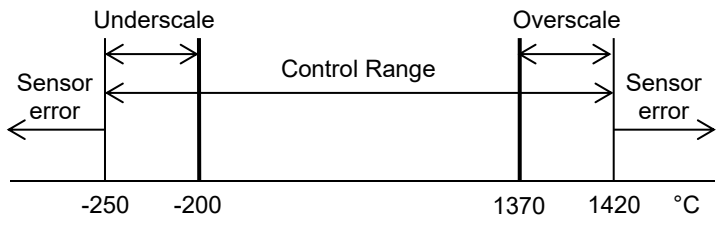
<p>Sensor Error</p>	<p>In the case of the following, a sensor error will occur, B5: Sensor error of status flag 2 will be set to "1: Error", and the control output will be turned off.</p> <p>Sensor error condition for thermocouple input (no decimal point)</p> <p>When the input range low limit is less than 50°C (90°F) and exceeds the input range high limit +50°C (90°F).</p> <p>At this time, PV is fixed to the of input range low limit 50°C (90°F) 1 digit and the input range high limit +50°C (90°F)+1 digit.</p> <p>Sensor error condition for thermocouple input (with decimal point) and RTD input</p> <p>When the input range low limit is less than 50°C (90°F) and exceeds the input range high limit +50°C (90°F)</p> <p>At this time, PV is fixed to the of input range low limit 50°C (90°F) 1 digit and the input range high limit +50°C (90°F)+1 digit.</p> <p>Sensor error condition for direct current input and DC voltage input</p> <p>When 4 to 20 mA DC and 1 to 5 V DC</p> <p>Scaling low limit -Scaling width × 10% or less</p> <p>At this time, PV is fixed to Scaling lower limit Scaling width × 10% 1 digit.</p> <p>When 0 to 1 V DC</p> <p>Scaling high limit Scaling width × 10% or more</p> <p>At this time, PV is fixed Scaling high limit scaling width × 10% + 1 digit.</p> <p>When 0 to 20 mA DC , 0 to 5 V DC and 0 to 10 V DC</p> <p>Value at 0 mA DC or 0 V DC input</p> <p>Relationship between sensor error, overscale, underscale, and control</p> <p>For input K: -200 to 1370°C</p>  <table border="1" data-bbox="486 1400 1460 1601"> <thead> <tr> <th>Control output</th> <th>OFF</th> <th colspan="3">ON</th> <th>OFF</th> </tr> </thead> <tbody> <tr> <td>B4 of status flag 1</td> <td>0</td> <td>0</td> <td>0</td> <td>1</td> <td>0</td> </tr> <tr> <td>B5 of status flag 1</td> <td>0</td> <td>1</td> <td>0</td> <td>0</td> <td>0</td> </tr> <tr> <td>B5 of status flag 2</td> <td>1</td> <td>0</td> <td>0</td> <td>0</td> <td>1</td> </tr> </tbody> </table> <p>(Fig. 17.1-3)</p>	Control output	OFF	ON			OFF	B4 of status flag 1	0	0	0	1	0	B5 of status flag 1	0	1	0	0	0	B5 of status flag 2	1	0	0	0	1
Control output	OFF	ON			OFF																				
B4 of status flag 1	0	0	0	1	0																				
B5 of status flag 1	0	1	0	0	0																				
B5 of status flag 2	1	0	0	0	1																				
<p>Cold junction error</p>	<p>If the internal cold junction temperature is less than -10°C (14°F) or more than 50°C (122°F), the cold junction error occurs and "1: Error" is set to B4: Cold junction error in status flag 2. (Valid only for channels for which thermocouple input is selected)</p>																								
<p>ADC error</p>	<p>If there is an abnormality such as a failure in the internal circuit, the ADC becomes abnormal, sets "1: Error" in status flag 2, B6: ADC error, and turns off the control output of the channel where the error occurred.</p> <p>At this time, PV becomes 32767.</p>																								
<p>Warm up indication</p>	<p>The power indicator flashes every 500 ms for about 3 seconds after the power is turned on.</p>																								

<p>Contact switching total number of times</p>	<p>The control output ON/OFF count can be integrated and measured. ON/OFF is set as one time and totaling is performed.</p> <p>This allows you to grasp the approximate contact life as the number of switching times of the switch used externally. However, since the saving cycle is 1 hour, the number of times within 1 hour may not be saved due to a power failure.</p>																																										
<p>Total energizing time measurement function</p>	<p>It can check the time that the power is on.</p> <p>The accumulated time is saved every 10 minutes.</p> <p>It can grasp the approximate usage time from the accumulated time. However, since the save cycle is 10 minutes, the time within 10 minutes may not be saved due to a power failure.</p> <p>Total energizing time: 10 minutes/count</p>																																										
<p>Heater accumulated energizing time</p>	<p>For relay contact output or non-contact voltage output, you can check the cumulative time the heater is energized.</p> <p>When the output time to the heater reaches 1 minute cumulatively, the count is added.</p> <p>The accumulated time is saved every 10 minutes.</p> <p>The accumulated time can be used to understand the approximate usage period of the heater, which can be used as a guide for replacing the heater. However, since the save cycle is 10 minutes, the time within 10 minutes may not be saved due to a power failure.</p> <p>Cumulative heater energization time: 1 minute/count</p>																																										
<p>Error history</p>	<p>When an error occurs, the bit ON/OFF and accumulated energization time are saved for the past 10 times.</p> <p>Error history exists for each channel, and device common errors are saved in the error history of all channels.</p> <p>Total energizing time: 1 hour/count</p> <table border="1" data-bbox="486 1406 1442 2101"> <thead> <tr> <th>Bit</th> <th colspan="2">Error content</th> </tr> </thead> <tbody> <tr> <td>B0</td> <td>Alarm 1</td> <td>0: Normal 1: Error</td> </tr> <tr> <td>B1</td> <td>Alarm 2</td> <td>0: Normal 1: Error</td> </tr> <tr> <td>B2</td> <td>Alarm 3</td> <td>0: Normal 1: Error</td> </tr> <tr> <td>B3</td> <td>Alarm 4</td> <td>0: Normal 1: Error</td> </tr> <tr> <td>B4</td> <td>Heater burnout alarm</td> <td>0: Normal 1: Error</td> </tr> <tr> <td>B5</td> <td>Undefined</td> <td>Indefinite</td> </tr> <tr> <td>B6</td> <td>Loop break alarm</td> <td>0: Normal 1: Error</td> </tr> <tr> <td>B7</td> <td>Sensor error</td> <td>0: Normal 1: Error</td> </tr> <tr> <td>B8</td> <td>Input error (Overscale)</td> <td>0: Normal 1: Error</td> </tr> <tr> <td>B9</td> <td>Input error (Underscale)</td> <td>0: Normal 1: Error</td> </tr> <tr> <td>B10</td> <td>Cold junction error</td> <td>0: Normal 1: Error</td> </tr> <tr> <td>B11</td> <td>Non-volatile IC memory error</td> <td>0: Normal 1: Error</td> </tr> <tr> <td>B12</td> <td>ADC error</td> <td>0: Normal 1: Error</td> </tr> </tbody> </table>	Bit	Error content		B0	Alarm 1	0: Normal 1: Error	B1	Alarm 2	0: Normal 1: Error	B2	Alarm 3	0: Normal 1: Error	B3	Alarm 4	0: Normal 1: Error	B4	Heater burnout alarm	0: Normal 1: Error	B5	Undefined	Indefinite	B6	Loop break alarm	0: Normal 1: Error	B7	Sensor error	0: Normal 1: Error	B8	Input error (Overscale)	0: Normal 1: Error	B9	Input error (Underscale)	0: Normal 1: Error	B10	Cold junction error	0: Normal 1: Error	B11	Non-volatile IC memory error	0: Normal 1: Error	B12	ADC error	0: Normal 1: Error
Bit	Error content																																										
B0	Alarm 1	0: Normal 1: Error																																									
B1	Alarm 2	0: Normal 1: Error																																									
B2	Alarm 3	0: Normal 1: Error																																									
B3	Alarm 4	0: Normal 1: Error																																									
B4	Heater burnout alarm	0: Normal 1: Error																																									
B5	Undefined	Indefinite																																									
B6	Loop break alarm	0: Normal 1: Error																																									
B7	Sensor error	0: Normal 1: Error																																									
B8	Input error (Overscale)	0: Normal 1: Error																																									
B9	Input error (Underscale)	0: Normal 1: Error																																									
B10	Cold junction error	0: Normal 1: Error																																									
B11	Non-volatile IC memory error	0: Normal 1: Error																																									
B12	ADC error	0: Normal 1: Error																																									

	<table border="1"> <thead> <tr> <th>Bit</th> <th colspan="2">Error content</th> </tr> </thead> <tbody> <tr> <td>B13</td> <td>Undefined</td> <td>Indefinite</td> </tr> <tr> <td>B14</td> <td>Undefined</td> <td>Indefinite</td> </tr> <tr> <td>B15</td> <td>Undefined</td> <td>Indefinite</td> </tr> </tbody> </table>	Bit	Error content		B13	Undefined	Indefinite	B14	Undefined	Indefinite	B15	Undefined	Indefinite
Bit	Error content												
B13	Undefined	Indefinite											
B14	Undefined	Indefinite											
B15	Undefined	Indefinite											
Console communication	<p>Connect a communication cable (commercial item) to the console communication connector, and</p> <p>The following operations can be performed from an external computer using the software (SWC-QTC101M).</p> <p>(1) Reading and setting of SV, PID and various set values</p> <p>(2) PV and operation status reading</p> <p>(3) Change of function</p> <table border="1"> <tr> <td>Communication protocol</td> <td>MODBUS RTU</td> </tr> <tr> <td>Communication cable</td> <td>USB - micro USB Type-B(commercial item)</td> </tr> <tr> <td>Software</td> <td>Console software (SWC-QTC101M)</td> </tr> </table>	Communication protocol	MODBUS RTU	Communication cable	USB - micro USB Type-B(commercial item)	Software	Console software (SWC-QTC101M)						
Communication protocol	MODBUS RTU												
Communication cable	USB - micro USB Type-B(commercial item)												
Software	Console software (SWC-QTC101M)												
Firmware update function	<p>Connect a communication cable (commercial item) to the console communication connector, and software (SWC-QTC101M) to update the function from an external computer.</p> <p>When the firmware is updated, the set values are initialized.</p>												

Other Item

Accessories	<p>Mounting and wiring instruction manual: 1</p> <p>Line cap: 1</p> <p>Power supply terminal cover: 1 (Included when power supply / host communication function is provided or when power supply / CUnet communication function is provided.)</p> <p>Connector for wiring (2ESS-05P): 4 (Connector type)</p>
Sold separately	<p>Shunt resistor: RES-S01-050 50 Ω</p> <p>Termination resistance: RES-S07-100 100 Ω</p> <p>Front terminal cover: TC-QTC</p> <p>CT: CTL-6-S-H (For heater burnout alarm 20 A)</p> <p>CTL-12-S36-10L1U (For heater burnout alarm 100 A)</p> <p>Connector harness for heater burnout alarm: WQ</p> <p>Connector harness for event input/output: EVQ</p>

17.2 Optional Specifications

Power supply and Communication	Perform the following operations from the external computer. (1) Reading and setting of SV, PID and various set values (2) PV and operation status reading (3) Change of function	
	Communication line	EIA RS-485 (C5 option)
	Communication method	Half-duplex communication
	Synchronization method	Start-stop synchronization
	Communication protocol	MODBUS RTU or SIF specifications can be selected by DIP switch
	Communication speed	9600 bps, 19200 bps, 38400 bps or 57600 bps can be selected by DIP switch
	Data bit/Parity/Stop bit	Select the following with the DIP switch Data bit: 8 Parity: Even, Odd, No parity Stop bit: 1 or 2
	Communication response delay time	Set the delay time to return the response from the module after receiving the command from the host. 0 to 1000 ms
<p>The SIF function (Smart InterFace, programless communication function) the PLC Q series manufactured by Mitsubishi Electric Corp. and this instrument, and reads and writes various data to and from PLC registers using the communication protocol of the PLC.</p>		
Communication protocol	Format 4	
Communication command	A compatible 1C frame AnA/AnU common command (QR/QW) (D register)	
<p>Using the console software (SWC-QTC101M), select the PLC register start number, PLC register address, the monitoring items and setting items to be linked, and set the specifications.</p> <p>The control module QTC1-4P becomes the master, and the selected monitor item is periodically written to the PLC register by using the QW command, and the value of the PLC register is constantly updated.</p> <p>In addition, the selected setting items are read from the PLC register in response to a setting request using the QR command.</p> <p>When the read data is changed, the set value of control module QTC1-4P or control module QTC1-40 is updated.</p>		

	<p>CUnet communication function</p> <p>CUnet communication writes the reading value from the module to the global memory (GM) specified by the station address (SA).</p> <p>It reads the setting values from the master address (DOSA) and sets them to the module.</p> <p>The setting value can also be changed by using the mail function of CUnet.</p> <table border="1" data-bbox="488 405 1461 1240"> <tr> <td>Connection type</td> <td colspan="2">Multi-drop</td> </tr> <tr> <td>Communication method</td> <td colspan="2">2-wire half-duplex</td> </tr> <tr> <td>Synchronization method</td> <td colspan="2">Bit-synchronous</td> </tr> <tr> <td>Error detection</td> <td colspan="2">CRC-16</td> </tr> <tr> <td>Number of occupied slave addresses</td> <td colspan="2">1</td> </tr> <tr> <td>Maximum number of connected nodes</td> <td colspan="2">64 nodes</td> </tr> <tr> <td rowspan="4">Communication speed, Communication distance</td> <td>Communication speed</td> <td>Maximum network length</td> </tr> <tr> <td>12 Mbps</td> <td>100 m</td> </tr> <tr> <td>6 Mbps</td> <td>200 m</td> </tr> <tr> <td>3 Mbps</td> <td>300 m</td> </tr> <tr> <td>Isolation method</td> <td colspan="2">Pulse transformer isolation</td> </tr> <tr> <td>Impedance</td> <td colspan="2">100 Ω</td> </tr> <tr> <td>Termination resistance</td> <td colspan="2">Last connection, set by CUnet slave This instrument is not equipped.</td> </tr> </table>	Connection type	Multi-drop		Communication method	2-wire half-duplex		Synchronization method	Bit-synchronous		Error detection	CRC-16		Number of occupied slave addresses	1		Maximum number of connected nodes	64 nodes		Communication speed, Communication distance	Communication speed	Maximum network length	12 Mbps	100 m	6 Mbps	200 m	3 Mbps	300 m	Isolation method	Pulse transformer isolation		Impedance	100 Ω		Termination resistance	Last connection, set by CUnet slave This instrument is not equipped.	
Connection type	Multi-drop																																				
Communication method	2-wire half-duplex																																				
Synchronization method	Bit-synchronous																																				
Error detection	CRC-16																																				
Number of occupied slave addresses	1																																				
Maximum number of connected nodes	64 nodes																																				
Communication speed, Communication distance	Communication speed	Maximum network length																																			
	12 Mbps	100 m																																			
	6 Mbps	200 m																																			
	3 Mbps	300 m																																			
Isolation method	Pulse transformer isolation																																				
Impedance	100 Ω																																				
Termination resistance	Last connection, set by CUnet slave This instrument is not equipped.																																				
<p>Heater burnout alarm</p>	<p>The heater current is monitored by CT (sold separately) to detect heater burnout.</p> <p>Cannot be added for direct current output, DC voltage output and Triac output.</p> <table border="1" data-bbox="488 1435 1461 1762"> <tr> <td>Rating</td> <td>Single phase 20 A, Single phase 100 A</td> </tr> <tr> <td>Setting range</td> <td>0.0 to 20.0 A (Setting 0.0 will not work) 0.0 to 100.0 A (Setting 0.0 will not work)</td> </tr> <tr> <td>Setting accuracy</td> <td>±5% of rated value</td> </tr> <tr> <td>Operating point</td> <td>Heater burnout alarm setting value</td> </tr> <tr> <td>Action</td> <td>ON/OFF action</td> </tr> <tr> <td>Output</td> <td>Event output allocation by status flag or event output allocation selection.</td> </tr> </table>	Rating	Single phase 20 A, Single phase 100 A	Setting range	0.0 to 20.0 A (Setting 0.0 will not work) 0.0 to 100.0 A (Setting 0.0 will not work)	Setting accuracy	±5% of rated value	Operating point	Heater burnout alarm setting value	Action	ON/OFF action	Output	Event output allocation by status flag or event output allocation selection.																								
Rating	Single phase 20 A, Single phase 100 A																																				
Setting range	0.0 to 20.0 A (Setting 0.0 will not work) 0.0 to 100.0 A (Setting 0.0 will not work)																																				
Setting accuracy	±5% of rated value																																				
Operating point	Heater burnout alarm setting value																																				
Action	ON/OFF action																																				
Output	Event output allocation by status flag or event output allocation selection.																																				

Event input	Operates with the content selected in event input allocation selection.		
	Setting value	Action	Contents
	0	No action	It can be used for any operation by reading the event input status flag. When the event input is turned off, the event input status flag is set to 0, and when the event input is turned on, the event input status flag is set to 1.
	1	Control start/stop (CH alone)	For the selected channel only, control will start when the event input turns ON, and control will stop when the event input turns OFF.
2	Control start/stop (CH interlock)	For all channels, turning on the event input starts the control, and turning off the event input stops the control.	
Event output	Operates with the content selected in event output allocation selection.		
	Setting value	Action	Contents
	0	No action	By selecting the event output ON/OFF selection from the host, the event output can be output. When the event output ON/OFF selection is set to 0 (event output OFF), the event output is turned off, and when it is set to 1 (event output ON), the event output is turned on.
	1	Control start/stop (CH alone)	The event output turns ON when any of the selected channel's alarm, heater burnout alarm, or loop error alarm is activated.
2	Control start/stop (CH interlock)	The event output turns on when an alarm, heater burnout alarm, or loop error alarm occurs on all channels.	

18 Troubleshooting

If any malfunctions occur, refer to the following items after checking that power is being supplied to the master module and slave module.

18.1 Communication (Host Communication)

Problem	Possible Cause	Solution
Cannot communicate.	Is the communication cable disconnected?	Check the communication cable.
	Is the communication cable wiring correct?	Refer to “7 Wiring (P.7-1 to P.7-9)” or “13.4 Wiring (P.13-8 to P.13-13)”, and check the communication cable.
	Is there any disconnection or contact failure of the communication cable?	Check the communication cable.
	Is communication speed of the master and slave same?	Refer to “5.1.1 Selection of Communication Specifications (P.5-1, P.5-2)”, and check the communication speed of the master and slave.
	Are data bits, parity, and stop bits of the master and slave same?	Refer to “5.1.1 Selection of Communication Specifications (P.5-1, P.5-2)”, and check the data bit, parity, and stop bit of the master and slave.
	Is the module address of the command and slave same?	Refer to “5.1.2 Selection of Module Address (P.5-3)”, and check the module address of the command and slave.
	Are there any slaves that have the same module address?	Refer to “5.1.2 Selection of Module Address (P.5-3)”, and check the module address.
	Is the program considering the transmission timing?	Refer to “9. Communication Procedure (P.9-1)”, and check the program.
Communication is possible, but a negative acknowledgement is returned.	Are sending a command code that does not exist?	Refer to “11.1 Communication Command List (P.11-1 to P.11-20)”, and check the command code.
	Is the data of the write command exceeding the setting range?	Refer to “11.1 Communication Command List (P.11-1 to P.11-20)”, and check the setting range of write command.
	Is it not possible to write (During AT execution)?	Check the state of a slave.

18.2 Communication (CUnet Communication)

Problem	Possible Cause	Solution
Cannot communicate.	Is the communication line wiring correct?	Refer to “14.4.3 Wiring Example of CUnet Communication Line (P.14-10)”, and check the wiring of the communication line.
	Is the termination resistance attached to the last module in the communication line?	Refer to “14.4.3 Wiring Example of CUnet Communication Line (P.14-10)”, and attach the termination resistance to the last module in the communication line.
	Is the LAN cable a straight cable?	If the LAN cable is a crossover cable, communication is not possible. Use a straight cable.
	Is the station address correct?	Refer to “14.2 Setting CUnet communication specifications (P.14-3)”, and check the settings.
	Are there duplicate station addresses?	Refer to “14.2 Setting CUnet communication specifications (P.14-3)” and set the station address to avoid duplication.
	Is the communication speed between the host system (master) and the module the same?	Refer to “14.2 Setting CUnet communication specifications (P.14-3)” and check the communication speed.

18.3 PV Reading Value

Problem	Possible Cause	Solution
PV reading is abnormal or unstable.	Are the sensor input and temperature unit (°C/°F) selection correct?	Select the correct sensor input and temperature unit (°C/°F).
	Is the sensor correction factor or sensor correction value set appropriately?	Set an appropriate sensor correction factor or sensor correction value.
	Are the sensor specifications correct?	Use a sensor with appropriate specifications.
	Is AC leaking to the sensor?	Make the sensor non-grounded.
	Is there a device nearby that causes inductive interference or noise?	Keep away from device that may cause inductive interference or noise.

18.4 Status Flag 1

Problem	Possible Cause	Solution
"1: Error" is set in B4: Input error (Overscale).	It is an overscale. Is PV over the input range high limit (scaling high limit for direct current input and DC voltage input)?	Check the input signal source is normal.
"1: Error" is set in B5: Input error (Underscale).	It is an underscale. Is PV below the input range low limit (scaling low limit for direct current input and DC voltage input)?	Check the input terminal wiring and input signal source are normal.
"1: Error" is set in B15: Non-volatile IC memory error.	The nonvolatile IC memory is defective.	Contact our agency or us.

18.5 Status Flag 2

Problem	Possible Cause	Solution
"1: Error" is set in B4: Cold junction error.	It is a cold junction error. If the internal cold junction temperature is lower than -10°C (14°F) or higher than 50°C (122°F), a cold junction error will occur.	Check the installation environment such as the ambient temperature of the instrument.
"1: Error" is set in B5: Sensor error.	It is a sensor error. Is the sensor burn out?	<p>Replace each sensor.</p> <p>How to check whether the sensor is burnt out</p> <ul style="list-style-type: none"> • For thermocouple If the input terminals of this instrument are short-circuited and the around room temperature is indicated, this instrument is normal and the sensor may be burn out. • For RTD If a resistance of approx. 100 Ω is connected to the input terminal (between A and B) of this instrument and the input terminal (between B and B) is short-circuited and the temperature is indicated as 0°C (32°F), this instrument is normal and the sensor may be burn out. • For DC voltage (0 to 1 V DC) If the input terminals of this instrument are short-circuited and the scaling low limit is indicated, this instrument is normal and the sensor may be burn out. • For direct current (4 to 20 mA DC) If the input terminals of this instrument input 4 mA DC and the scaling low limit is indicated, this instrument is normal and the sensor

Problem	Possible Cause	Solution
		<p>may be burn out.</p> <ul style="list-style-type: none"> For DC voltage (1 to 5 V DC) If the input terminals of this instrument input 1 V DC and the scaling low limit is indicated, this instrument is normal and the sensor may be burn out.
"1: Error" is set in B5: Sensor error.	<p>It is a sensor error. Is the sensor burn out?</p>	<ul style="list-style-type: none"> For direct current (0 to 20 mA DC) If the input terminals of this instrument input 4 mA DC and the input value is a value converted by scaling high and low limit settings, this instrument is normal and the sensor may be burn out. For DC voltage (0 to 5 V DC, 0 to 10 V DC) If the input terminals of this instrument input 1 V DC and the input value is a value converted by scaling high and low limit settings, this instrument is normal and the sensor may be burn out.
"1: Error" is set in B6: ADC error.	It is the internal circuit error.	Contact our agency or us.

18.6 Control

Problem	Possible Cause	Solution
Control output does not turn on.	Is Prohibited selected in Control Allowed/Prohibited selection?	Select Prohibited in Control Allowed/Prohibited selection.
	Is the SV setting appropriate?	Set the appropriate SV.
The temperature does not rise.	Is the sensor broken?	Replace the sensor.
	Is the sensor or control output terminal securely attached to the input terminal of this instrument?	Attach the sensor or control output terminal to the input terminal of this instrument securely.
	Is the sensor or control output terminal wiring correct?	Wire correctly.
Control output remains ON.	Is the output low limit set to 100% or higher?	Set an appropriate value.
Control output remains OFF.	Is the output high limit set to 0% or less?	Set an appropriate value.
Chattering occurs with ON-OFF control.	Is the ON/OFF hysteresis setting too small?	Set an appropriate value.
Chattering occurs with PID control, PI control, PD control or P control.	Is the proportional cycle too small?	Set an appropriate value.

18.7 Loop Break Alarm

Problem	Possible Cause	Solution
The loop break alarm is activated even though the control terminal is normal.	Is the loop break alarm band setting too large for the loop break alarm time setting?	Set an appropriate loop break alarm band setting.
	Is the loop break alarm time setting too small for the loop break alarm band setting?	Set an appropriate loop break alarm time setting.

18.8 Heater Burnout Alarm

Problem	Possible Cause	Solution
Heater burnout alarm does not work.	Is the CT wiring correct?	Wire correctly.
	Is the control output turned ON?	The heater current value is updated when the control output is ON. Check the control parameter.
	Is the heater burnout alarm setting appropriate?	Set an appropriate heater burnout alarm setting. Set it to about 80% of the heater current value considering the fluctuation of the power supply voltage. If 0.0 is set, heater burnout alarm does not work.
Heater burnout alarm cannot be canceled.	Is the heater burnout alarm setting appropriate?	Set an appropriate heater burnout alarm setting. Set a value smaller than the heater current value when the control output is ON.
	After the heater burnout alarm is activated, is the control output turned ON and the heater current value updated?	The heater burnout alarm cannot be canceled unless the heater current value is updated to the normal value. Check the control parameter.

SHINKO TECHNOS CO., LTD.
OVERSEAS DIVISION

Head Office: 2-5-1, Senbahigashi, Minoo, Osaka, 562-0035, Japan

[URL] <https://shinko-technos.co.jp/e/>

Tel: +81-72-727-6100

[E-mail] overseas@shinko-technos.co.jp

Fax: +81-72-727-7006