

DC SIGNAL ALARM UNIT

SGAL

INSTRUCTION MANUAL

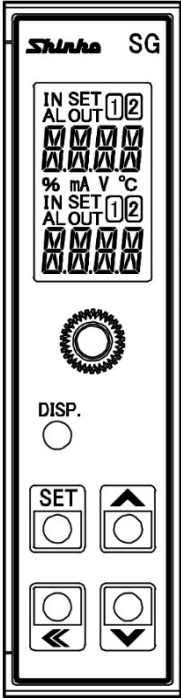

Shinko

Preface

Thank you for purchasing our SGAL, DC Signal Alarm Unit. This manual contains instructions for the mounting, functions, operations and notes when operating the SGAL. To prevent accidents arising from the misuse of this instrument, please ensure the operator receives this manual.

Notes

- This instrument should be used in accordance with the specifications described in the manual. If it is not used according to the specifications, it may malfunction or cause a fire.
- Be sure to follow the warnings, cautions and notices. If they are not observed, serious injury or malfunction may occur.
- The contents of this instruction manual are subject to change without notice.
- Care has been taken to ensure that the contents of this instruction manual are correct, but if there are any doubts, mistakes or questions, please inform our sales department.
- This instrument is designed to be installed on a DIN rail within a control panel. If it is not, measures must be taken to ensure that the operator does not touch power terminals or other high voltage sections.
- Any unauthorized transfer or copying of this document, in part or in whole, is prohibited.
- Shinko Technos CO., LTD. is not liable for any damage or secondary damage(s) incurred as a result of using this product, including any indirect damage.

SAFETY PRECAUTIONS (Be sure to read these precautions before using our products.)

The safety precautions are classified into categories: "Warning" and "Caution".

Depending on circumstances, procedures indicated by  Caution may result in serious consequences, so be sure to follow the directions for usage.



Warning

Procedures which may lead to dangerous conditions and cause death or serious injury, if not carried out properly.



Caution

Procedures which may lead to dangerous conditions and cause superficial to medium injury or physical damage or may degrade or damage the product, if not carried out properly.



Warning

- To prevent an electrical shock or fire, only Shinko or qualified service personnel may handle the inner assembly.
- To prevent an electrical shock, fire, or damage to instrument, parts replacement may only be undertaken by Shinko or qualified service personnel.



Safety Precautions

- To ensure safe and correct use, thoroughly read and understand this manual before using this instrument.
- This instrument is intended to be used for industrial machinery, machine tools and measuring equipment. Verify correct usage after purpose-of-use consultation with our agency or main office. (Never use this instrument for medical purposes with which human lives are involved.)
- External protection devices such as protection equipment against excessive temperature rise, etc. must be installed, as malfunction of this product could result in serious damage to the system or injury to personnel. Proper periodic maintenance is also required.
- This instrument must be used under the conditions and environment described in this manual. Shinko Technos Co., Ltd. does not accept liability for any injury, loss of life or damage occurring due to the instrument being used under conditions not otherwise stated in this manual.



Caution with Respect to Export Trade Control Ordinance

To avoid this instrument from being used as a component in, or as being utilized in the manufacture of weapons of mass destruction (i.e. military applications, military equipment, etc.), please investigate the end users and the final use of this instrument.
In the case of resale, ensure that this instrument is not illegally exported.

■ Installation Precautions



Caution

This instrument is intended to be used under the following environmental conditions (IEC61010-1): Overvoltage category II, Pollution degree 2

Ensure the mounting location corresponds to the following conditions:

- A minimum of dust, and an absence of corrosive gases
- No flammable, explosive gases
- No mechanical vibrations or shocks
- No exposure to direct sunlight, an ambient temperature of -10 to 55°C (14 to 131°F) that does not change rapidly, and no icing
- An ambient non-condensing humidity of 35 to 85 %RH
- No large capacity electromagnetic switches or cables through which large current is flowing
- No water, oil or chemicals or the vapors of these substances can come into direct contact with the unit.
- When installing this unit within a control panel, please note that ambient temperature of this unit – not the ambient temperature of the control panel – must not exceed 55°C (131°F). Otherwise the life of electronic components (especially electrolytic capacitor) may be shortened.

Note: Avoid setting this instrument directly on or near flammable material even though the case of this instrument is made of flame-resistant resin.

■ Wiring Precautions



Caution

- Do not leave wire remnants in the instrument, as they could cause a fire and malfunction.
- When wiring, use a crimping pliers and a solderless terminal with an insulation sleeve in which an M3 screw fits.
- Tighten the terminal screw using the specified torque. If excessive force is applied to the screw when tightening, the screw or case may be damaged.
- This instrument does not have a built-in power switch, circuit breaker and fuse. It is necessary to install a power switch, circuit breaker and fuse near the instrument.
(Recommended fuse: Time-lag fuse, rated voltage 250 V AC, rated current 2 A)
- For wiring of the AC power source, be sure to use terminals as described in this manual. If the AC power source is connected to incorrect terminals, the unit will be burnt out.
- Do not apply a commercial power source to the sensor which is connected to the input terminal nor allow the power source to come into contact with the sensor.
- When using DC voltage and current input, do not confuse polarity when wiring.
- Keep the input/output wires and power line separate.

■ Operation and Maintenance Precautions



Caution

- Do not touch live terminals. This may cause an electrical shock or problems in operation.
- Turn the power supply to the instrument OFF when retightening the terminal or cleaning. Working on or touching the terminal with the power switched ON may result in severe injury or death due to electrical shock.
- Use a soft, dry cloth when cleaning the instrument.
(Alcohol based substances may tarnish or deface the unit.)
- As the display section is vulnerable, be careful not to put pressure on, scratch or strike it with a hard object.

Characters used in this manual [X] : No character is indicated (unlit.)

Indication	1	0	1	2	3	4	5	6	7	8	9	℃	℉
Number, °C/℉	-1	0	1	2	3	4	5	6	7	8	9	°C	°F
Indication	A	b	C	d	E	F	G	H	I	J	K	L	M
Alphabet	A	B	C	D	E	F	G	H	I	J	K	L	M
Indication	N	o	P	Q	R	S	T	U	V	W	X	Y	Z
Alphabet	N	O	P	Q	R	S	T	U	V	W	X	Y	Z

CONTENTS

	Page
1. Model	5
1.1 Model.....	5
1.2 How to Read the Model Label.....	5
2. Name and Functions	6
2.1 Front Panel.....	6
2.2 Display Section.....	7
3. Mounting	8
3.1 External Dimensions (Scale: mm).....	8
3.2 Mounting to, and Removal from the DIN Rail.....	9
4. Wiring	10
4.1 Lead Wire Solderless Terminal.....	10
4.2 Circuit Configuration.....	10
4.3 Terminal Arrangement.....	12
4.4 Wiring.....	13
5. Display Mode	14
6. Simple Setting Mode	18
6.1 Display Transition for 2-outputs.....	18
6.2 Display Transition for 4-outputs.....	18
7. Setting Mode	19
7.1 Display Transition in Setting Mode.....	19
7.2 Input Setting Mode.....	21
7.3 Alarm 1 Setting Mode.....	23
7.4 Alarm 2 Setting Mode.....	25
7.5 Alarm 3 Setting Mode.....	27
7.6 Alarm 4 Setting Mode.....	29
7.7 Instrument Setting Mode.....	31
7.8 Custom Display Setting Mode.....	33
7.9 Manual Mode.....	34
8. Operation	35
8.1 Indication after power is turned ON.....	35
8.2 Alarm 1 to Alarm 4 Value Setting.....	35
8.2.1 Basic Operation for Setting Alarm 1 to Alarm 4 Value.....	35
8.2.2 Alarm 1 to Alarm 4 Value.....	35
8.3 Operation.....	36
8.3.1 Alarm Output Indication.....	36
8.3.2 Input Indication Range.....	36
8.3.3 Input Disconnection.....	36
8.3.4 Indication Time Setting.....	36
9. Specifications	37
10. Troubleshooting	39
10.1 Indication.....	39
10.2 Key Operation.....	39
10.3 Operation.....	39
11. Character Table	40

1. Model

1.1 Model

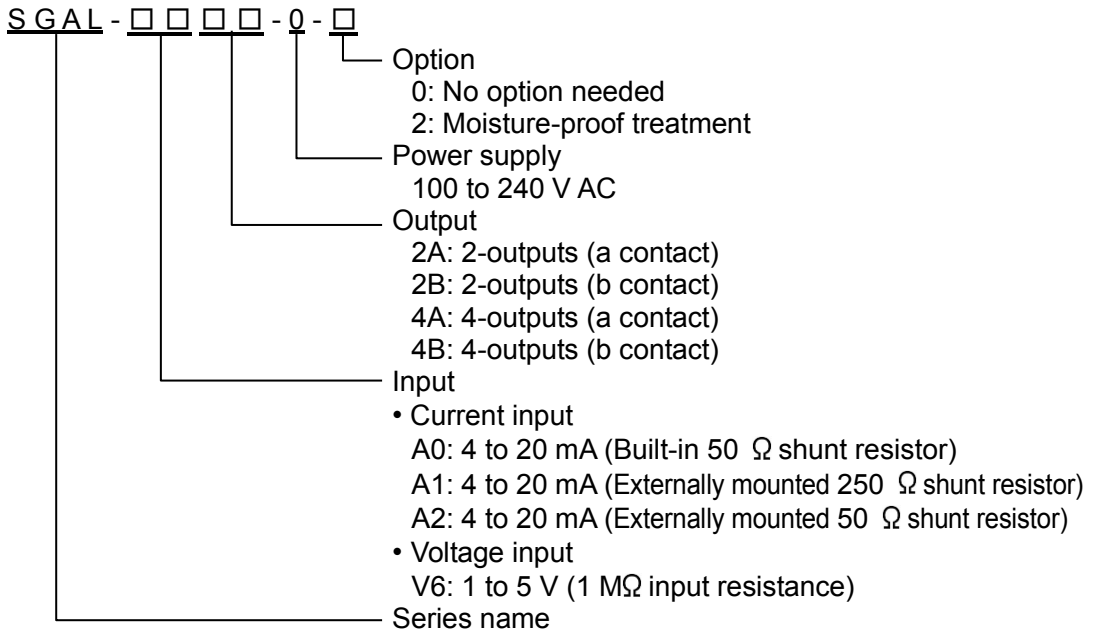

1.2 How to Read the Model Label

The model label is attached to the right side of the case.

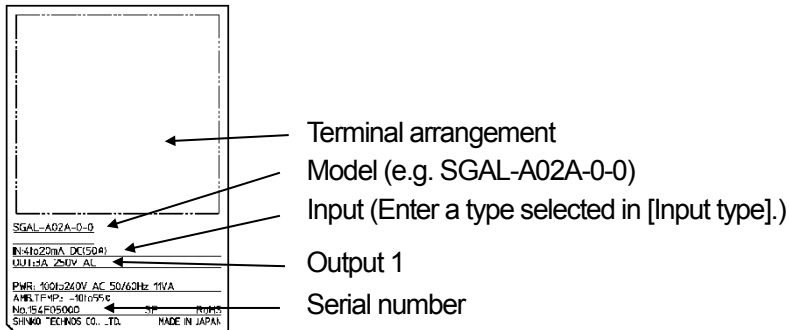

(Fig. 1.2-1)

2. Name and Functions

2.1 Front Panel

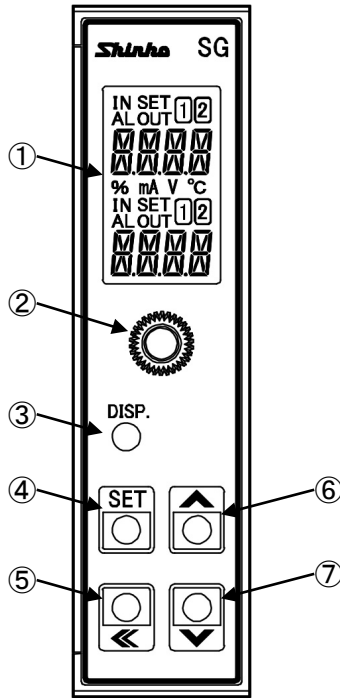

(Fig. 2.1-1)

①	Display section	Indicates setting contents, input value, alarm value, etc.
②	Mounting screw	Used for fixing the instrument to the socket or removal from it.
③	DISP key	Switches the displays, and moves to the next setting item. In manual mode, each alarm output can be selected. Releases the lock status of the DISP key by pressing for 3 seconds.
④	SET key	Selects the setting mode. Shifts the digit in Custom display setting mode. Enters the setting mode by pressing and holding for 5 seconds.
⑤	SHIFT key	Shifts the digit of setting value.
⑥	UP key	Increases the numerical value. Contents of Multi-Display A and B can be changed alternately when Default Display is RUN display mode 1, 2, 3, 4, 5, 6 and 7.
⑦	DOWN key	Decreases the numerical value. Enters Manual mode by pressing for 3 seconds.

2.2 Display Section

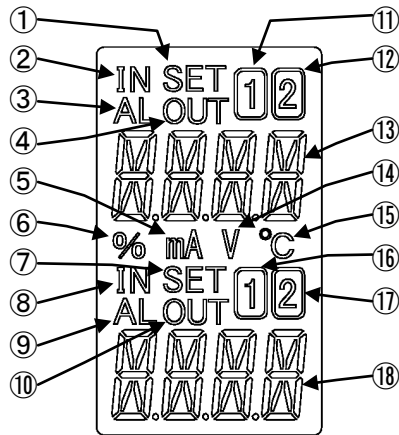

(Fig. 2.2-1)

①	Setting display indicator A	Lights up when setting value is indicated.
②	Input indicator A	Lights up when Multi-Display A indicates an input value.
③	Alarm indicator A	Lights up when alarm action is activated, or if an input error or input disconnection occurs.
④	Output indicator A	Lights up when alarm output is ON.
⑤	mA indicator	Lights up when mA is selected in [Indication unit].
⑥	% indicator	Lights up when % is selected in [Indication unit].
⑦	Setting display indicator B	Lights up when setting value is indicated.
⑧	Input indicator B	Lights up when Multi-Display B indicates an input value.
⑨	Alarm indicator B	Lights up when alarm action is activated, or if an input error or input disconnection occurs.
⑩	Output indicator B	Lights up when alarm output is ON.
⑪	1 indicator A	Lights up when Multi-Display A indicates Alarm 1 value. Flashes when Multi-Display A indicates Alarm 3 value.
⑫	2 indicator A	Lights up when Multi-Display A indicates Alarm 2 value. Flashes when Multi-Display A indicates Alarm 4 value.
⑬	Multi-Display A	Indicates the following in accordance with the display indication: Input value, alarm value, custom characters, setting item, active alarm number (ALM1 to ALM4) when each alarm output is ON (when ENABLED is selected in [Alarm indication Enabled/Disabled])
⑭	V indicator	Lights up when V is selected in [Indication unit].
⑮	°C indicator	Lights up when °C is selected in [Indication unit].
⑯	1 indicator B	Lights up when Multi-Display B indicates Alarm 1 value. Flashes when Multi-Display B indicates Alarm 3 value.
⑰	2 indicator B	Lights up when Multi-Display B indicates Alarm 2 value. Flashes when Multi-Display B indicates Alarm 4 value.
⑱	Multi-Display B	Indicates the following in accordance with the display indication: Input value, alarm value, custom characters, setting value

Output indicators A and B, Alarm indicators A and B: Red
Other indicators: White

3. Mounting

3.1 External Dimensions (Scale: mm)

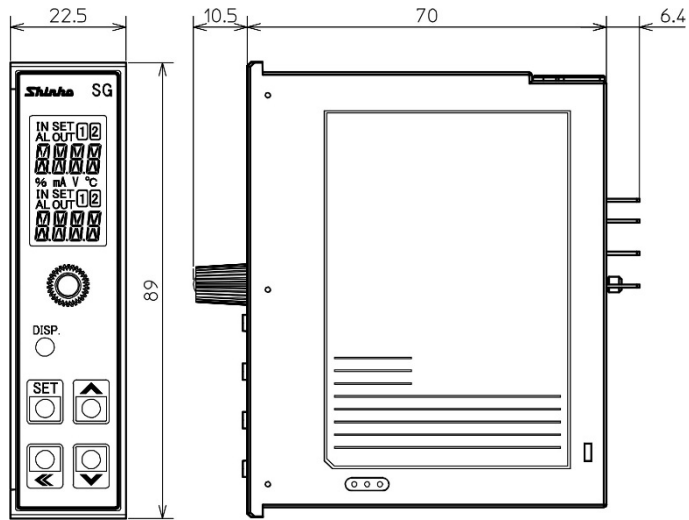

11P socket

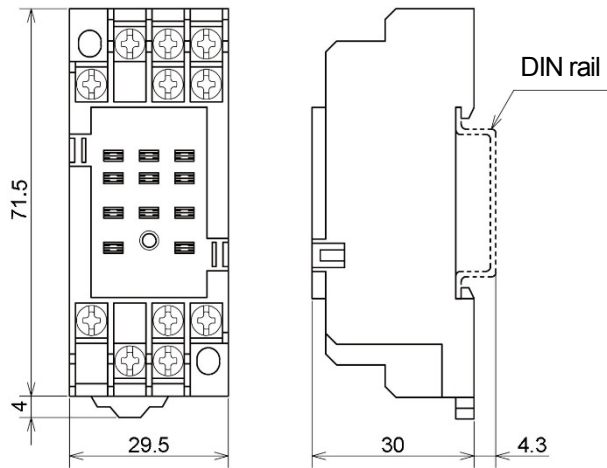

(Fig. 3.1-1)

3.2 Mounting to, and Removal from the DIN Rail

Caution

- Mount the DIN rail horizontally.
- To remove the socket, a flat blade screwdriver is required.
Never turn the screwdriver when inserting it into the Lock lever. If excessive power is applied to the lever, it may break.
- If the instrument is mounted in a position susceptible to vibration or shock, mount commercially available fastening plates at both ends of the instrument.

Recommended Fastening Plate

Manufacturer	Model	
Omron Corporation	End plate	PFP-M
IDEC Corporation	Fastening plate	BNL6
Panasonic Electric Works Co., Ltd.	Fastening plate	ATA4806

Mounting to the DIN rail (Fig. 3.2-1)

- ① Separate the instrument from the socket by loosening the mounting screw on the front panel.
- ② Make sure the lock lever of the socket is located in the lower part of the socket.
Hook the upper side of the socket onto the DIN rail, then fit the lower part of the socket onto the DIN rail (A clicking sound should be heard when done properly).

Caution

- Before inserting the instrument to the socket, make sure the cable is wired properly. (Refer to “4. Wiring”.)
- When inserting or removing the socket, make sure the socket is oriented vertically. If force is applied in any other direction than vertically, a malfunction may occur.
- If the mounting screw is fastened too tightly, a malfunction may occur.

- ③ Insert the SGAL into the socket.
- ④ Fasten the mounting screw by turning it clockwise, to secure the SGAL onto the socket.
Tighten the screw lightly.

Removal from the DIN rail (Fig. 3.2-2)

- ① Turn the power to the instrument OFF.
- ② Separate the instrument from the socket by loosening the mounting screw on the front panel.
- ③ Insert a flat blade screwdriver into the Lock lever (lower part of the socket), and remove the socket from the DIN rail while pulling the lever down.

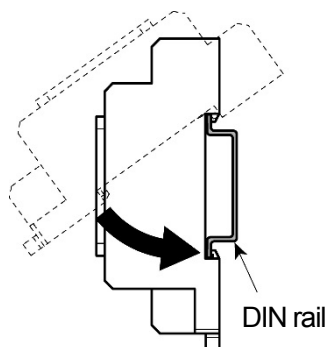

(Fig. 3.2-1)

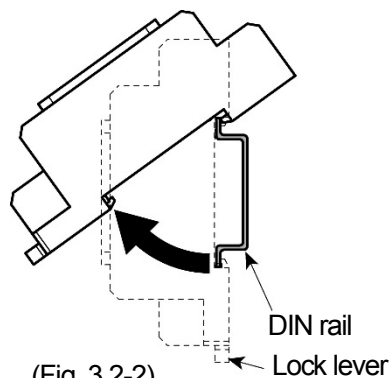

(Fig. 3.2-2)

4. Wiring



Warning

Turn the power supply to the instrument off before wiring or checking.
 Working on or touching the terminal with the power switched on may result in severe injury or death due to electrical shock.

4.1 Lead Wire Solderless Terminal

Use a solderless terminal with an insulation sleeve in which an M3 screw fits as shown below.
 The torque should be 0.63 N·m.

Solderless Terminal	Manufacturer	Model
Y-type	Nichifu Terminal Industries Co., Ltd.	TMEV1.25Y-3
	Japan Solderless Terminal MFG Co., Ltd.	VD1.25-B3A
Ring-type	Nichifu Terminal Industries Co., Ltd.	TMEV1.25-3
	Japan Solderless Terminal MFG Co., Ltd.	V1.25-3

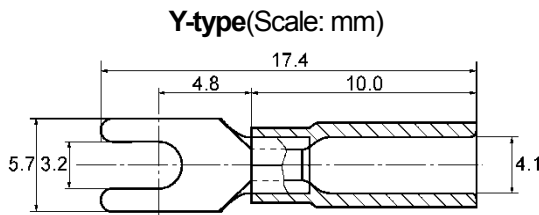

(Fig. 4.1-1)

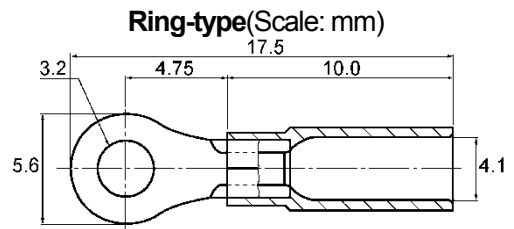

(Fig. 4.1-2)

4.2 Circuit Configuration

2-outputs (a contact)

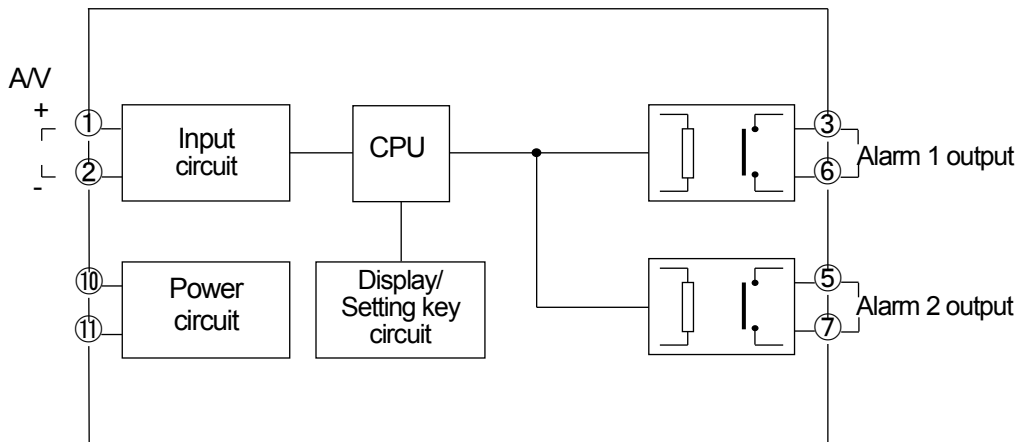

(Fig. 4.2-1)

2-outputs (b contact)

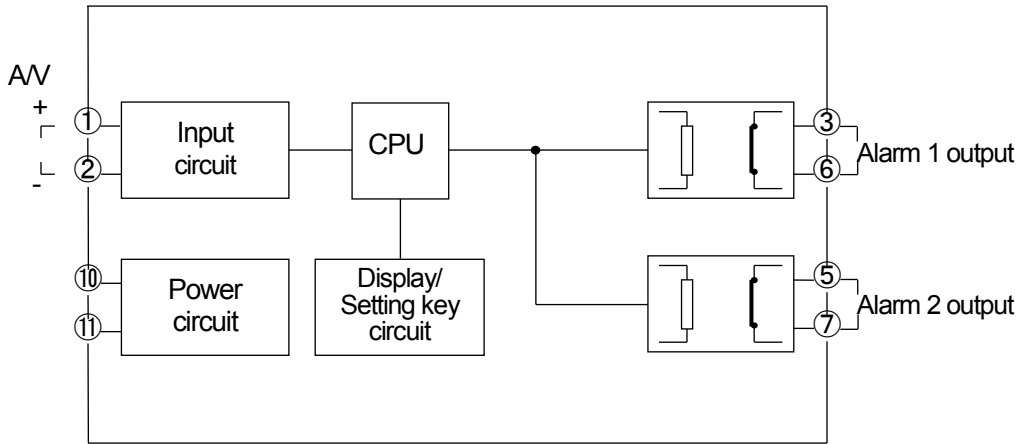

(Fig. 4.2-2)

4-outputs (a contact)

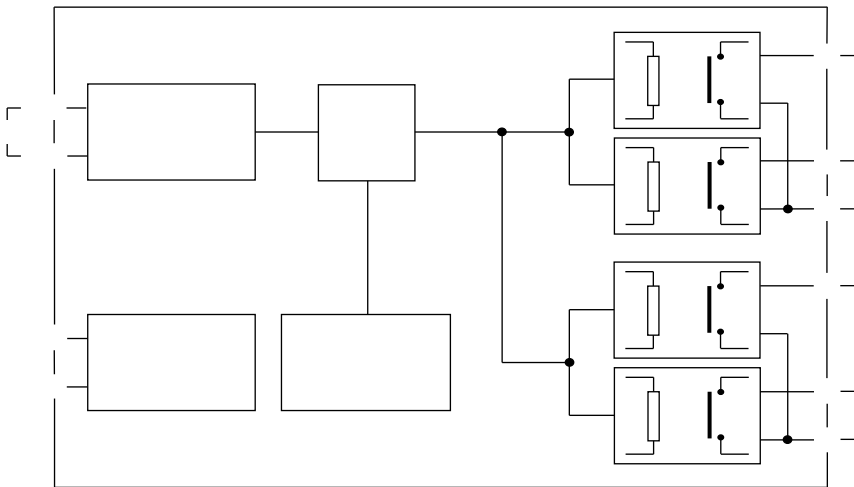

(Fig. 4.2-3)

4-outputs (b contact)

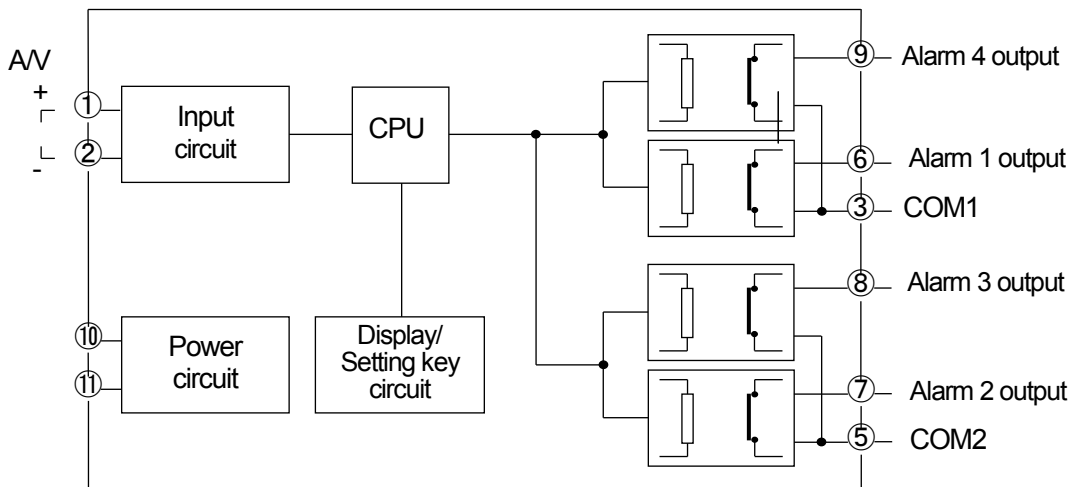

(Fig. 4.2-4)

4.3 Terminal Arrangement

2-outputs (a contact)

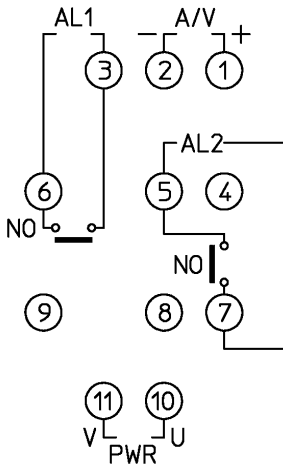

(Fig. 4.3-1)

2-outputs (b contact)

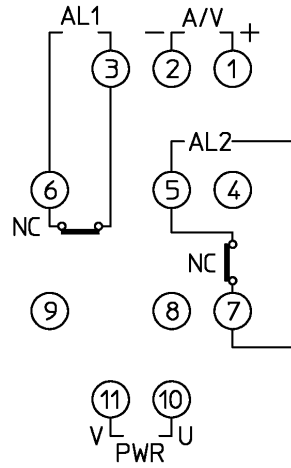

(Fig. 4.3-2)

4-outputs (a contact)

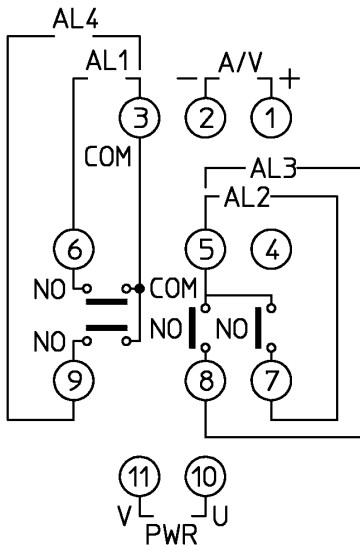

(Fig. 4.3-3)

4-outputs (b contact)

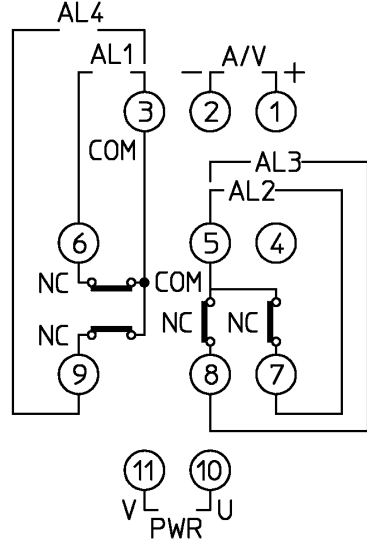

(Fig. 4.3-4)

PWR	Power supply 100 to 240 V AC
A	Direct current input
V	DC voltage input
AL1	Alarm 1 output
AL2	Alarm 2 output
AL3	Alarm 3 output(only for 4-outputs spec)
AL4	Alarm 4 output(only for 4-outputs spec)

4.4 Wiring



Warning

- For 100 to 240 V AC, if the AC power source is connected to incorrect terminals, the instrument will be burnt out.

(1) Power Source Wiring

Use terminals ⑩ and ⑪ for the power supply to the instrument.

(2) Output Wiring

2-outputs: Alarm 1 output: Use terminals ③ and ⑥.

Alarm 2 output: Use terminals ⑤ and ⑦.

4-outputs: Alarm 1 output: Use terminals ③ and ⑥.

Alarm 2 output: Use terminals ⑤ and ⑦.

Alarm 3 output: Use terminals ⑤ and ⑧.

Alarm 4 output: Use terminals ③ and ⑨.

(3) Input Wiring

Use terminals ①(+) and ②(-) for input wiring.

For the input code A1 or A2, connect a shunt resistor between terminals ① and ②.

5. Display Mode

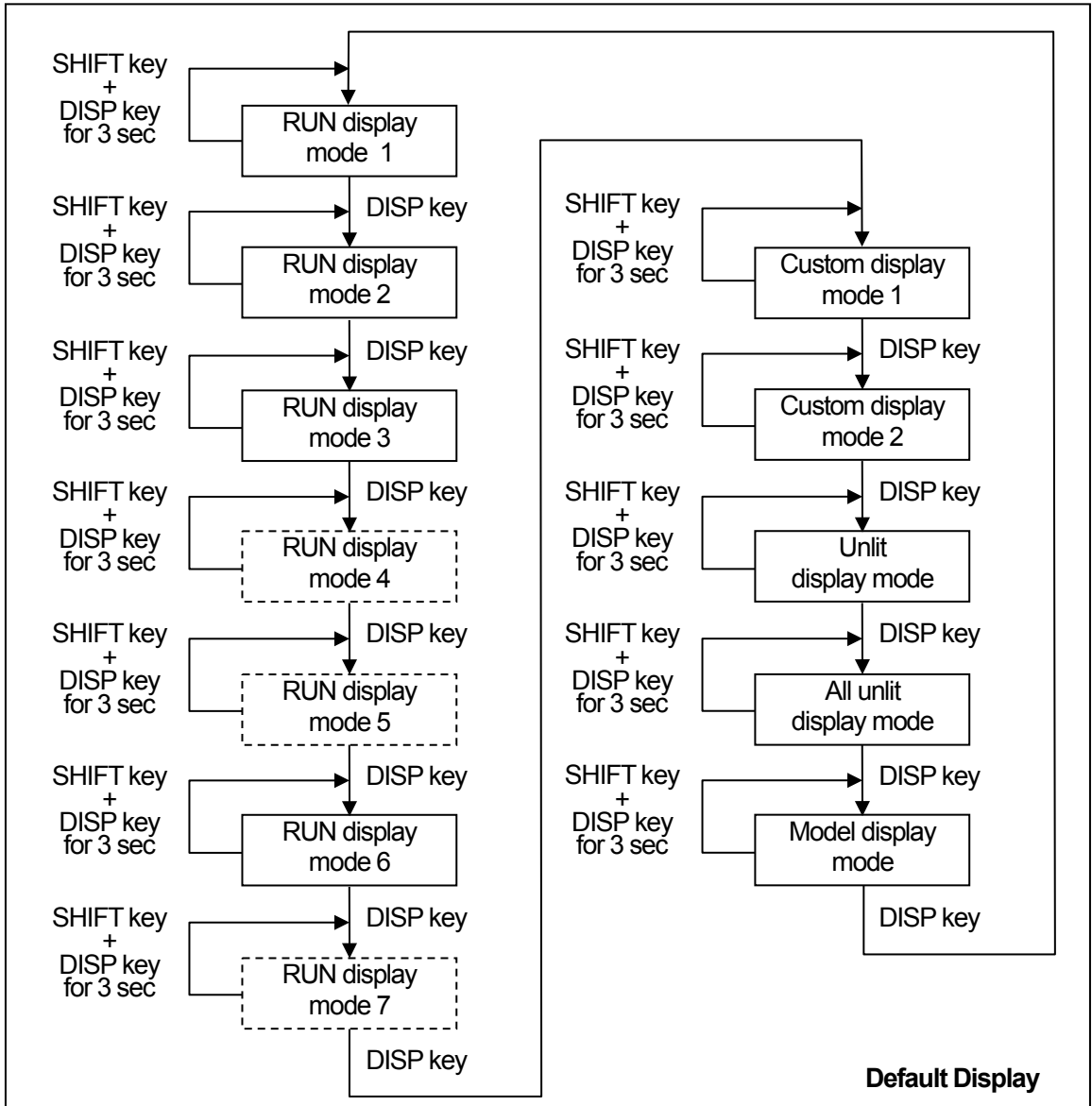

• [-----]: Available only for 4-outputs spec.

Default Display:

- If the SHIFT and DISP keys (in that order) are pressed together for approx. 3 seconds in any display mode, the display mode will become Default Display.
- Once the Default Display is set, the DISP key will be in lock status.
- If the DISP key is pressed for approx. 3 seconds on the Default Display, the key lock status will be cancelled.
- If the DISP key is pressed while the DISP key is in lock status, Multi-Display A indicates **LOCK**.

- RUN display mode 1:** Multi-Display A indicates an input value, and Multi-Display B is unlit.
- If an alarm is activated, the Alarm indicator A and the Output indicator A will light up.
 - When ENABLED is selected in [Alarm indication Enabled/Disabled]:
An active alarm (ALM1 to ALM4) is indicated on Multi-Display A.
 - If multiple alarms are activated, the smallest alarm number will be displayed.
- RUN display mode 2:**
- Multi-Display A indicates an input value, Multi-Display B indicates Alarm 1 value, and 1 indicator B lights up.
 - By pressing the SET key, the unit enters Simple setting mode (see p.17), and the alarm value can be set.
 - If Alarm 1 is activated, the Alarm indicator A and the Output indicator A will light up.
 - If any of Alarm 2, 3 or 4 is activated, only Alarm indicator A will light up.
 - When ENABLED is selected in [Alarm indication Enabled/Disabled]:
An active alarm (ALM1 to ALM4) is indicated on Multi-Display A.
 - If multiple alarms are activated, the smallest alarm number will be displayed.
- RUN display mode 3:**
- Multi-Display A indicates an input value, and Multi-Display B indicates Alarm 2 value. 2 indicator B lights up.
 - By pressing the SET key, the unit enters Simple setting mode (see p.17), and the alarm value can be set.
 - If Alarm 2 is activated, the Alarm indicator A and the Output indicator A will light up.
 - If any of Alarm 1, 3 or 4 is activated, only Alarm indicator A will light up.
 - When ENABLED is selected in [Alarm indication Enabled/Disabled]:
An active alarm (ALM1 to ALM4) is indicated on the Multi-Display A.
 - If multiple alarms are activated, the smallest alarm number will be displayed.
- RUN display mode 4:**
(only for 4-outputs spec)
- Multi-Display A indicates an input value, Multi-Display B indicates Alarm 3 value, and 1 indicator B flashes.
 - By pressing the SET key, the unit enters Simple setting mode (see p.17), and the alarm value can be set.
 - If Alarm 3 is activated, Alarm indicator A and the Output indicator A will light up.
 - If any of Alarm 1, 2 or 4 is activated, only Alarm indicator A will light up.
 - When ENABLED is selected in [Alarm indication Enabled/Disabled]:
An active alarm (ALM1 to ALM4) is indicated on the Multi-Display A.
 - If multiple alarms are activated, the smallest alarm number will be displayed.
- RUN display mode 5:**
(only for 4-outputs spec)
- Multi-Display A indicates an input value, and Multi-Display B indicates Alarm 4 value. 2 indicator B flashes.
 - By pressing the SET key, the unit enters Simple setting mode (see p.17), and alarm value can be set.
 - If Alarm 4 is activated, Alarm indicator A and the Output indicator A will light up.
 - If any of Alarm 1, 2 or 3 is activated, only Alarm indicator A will light up.
 - When ENABLED is selected in [Alarm indication Enabled/Disabled]:
An active alarm (ALM1 to ALM4) is indicated on the Multi-Display A.
 - If multiple alarms are activated, the smallest alarm number will be displayed.

- RUN display mode 6:**
- Multi-Display A indicates Alarm 1 value, and Multi-Display B indicates Alarm 2 value. **1** indicator A and **2** indicator B light up.
 - By pressing the SET key, the unit enters Simple setting mode (see p.17), and the alarm value can be set.
 - If Alarm 1 is activated, Alarm indicator A and the Output indicator A will light up.
 - If Alarm 2 is activated, Alarm indicator A and the Output indicator B will light up.
 - If Alarm 3 or 4 is activated, only Alarm indicator A will light up.
 - When ENABLED is selected in [Alarm indication Enabled/Disabled]:
An active alarm (ALM1 to ALM4) is indicated on the Multi-Display A.
 - If multiple alarms are activated, the smallest alarm number will be displayed.
- RUN display mode 7:**
(only for 4-outputs spec)
- Multi-Display A indicates Alarm 3 value, and Multi-Display B indicates Alarm 4 value. **1** indicator A and **2** indicator B flashes.
 - By pressing the SET key, the unit enters Simple setting mode (see p.17), and the alarm value can be set.
 - If Alarm 3 is activated, Alarm indicator A and the Output indicator A will light up.
 - If Alarm 4 is activated, Alarm indicator A and the Output indicator B will light up.
 - If Alarm 1 or 2 is activated, only Alarm indicator A will light up.
 - When ENABLED is selected in [Alarm indication Enabled/Disabled]:
An active alarm (ALM1 to ALM4) is indicated on the Multi-Display A.
 - If multiple alarms are activated, the smallest alarm number will be displayed.
- Custom display mode 1:**
- Multi-Display A indicates characters set in [Multi-Display A], and Multi-Display B indicates characters set in [Multi-Display B].
 - If an alarm is activated, Alarm indicator A and the Output indicator A will light up.
 - When ENABLED is selected in [Alarm indication Enabled/Disabled]:
An active alarm (ALM1 to ALM4) is indicated on the Multi-Display A.
 - If multiple alarms are activated, the smallest alarm number will be displayed.
- Custom display mode 2:**
- Multi-Display A indicates an input value, and Multi-Display B indicates characters set in [Multi-Display B].
 - If an alarm is activated, Alarm indicator A and Output indicator A will light up.
 - When ENABLED is selected in [Alarm indication Enabled/Disabled]:
An active alarm (ALM1 to ALM4) is indicated on the Multi-Display A.
 - If multiple alarms are activated, the smallest alarm number will be displayed.
- Unlit display mode:**
- Multi-Display A and B are unlit, and Input indicator A lights up.
 - If an alarm is activated, Alarm indicator A and the Output indicator A will light up.
 - When ENABLED is selected in [Alarm indication Enabled/Disabled]:
An active alarm (ALM1 to ALM4) is indicated on the Multi-Display A.
 - If multiple alarms are activated, the smallest alarm number will be displayed.

- All unlit display mode:**
- All displays and indicators are unlit.
 - Alarm indicator A does not light up even though it is under conditions of lighting.
- Model display mode:**
- Multi-Display A indicates a model name, and Multi-Display B indicates an input code and output code.
 - If an alarm is activated, Alarm indicator A and the Output indicator A will light up.
 - When ENABLED is selected in [Alarm indication Enabled/Disabled]:
An active alarm (ALM1 to ALM4) is indicated on the Multi-Display A.
 - If multiple alarms are activated, the smallest alarm number will be displayed.

6. Simple Setting Mode

If the SET key is pressed in RUN display mode 2 to 7, any one (from AL_{11} to AL_{14}) is indicated on the Multi-Display A, an alarm value on the Multi-Display B flashes, and it is possible to change the alarm value.

Change the value, then press the SET or DISP key to save (register) it. The unit returns to the following status:

Multi-Display A indicates an input value, and Multi-Display B indicates an alarm value.

Note: The unit cannot move to RUN display mode for which the alarm value has not been set.

6.1 Display Transition for 2-outputs

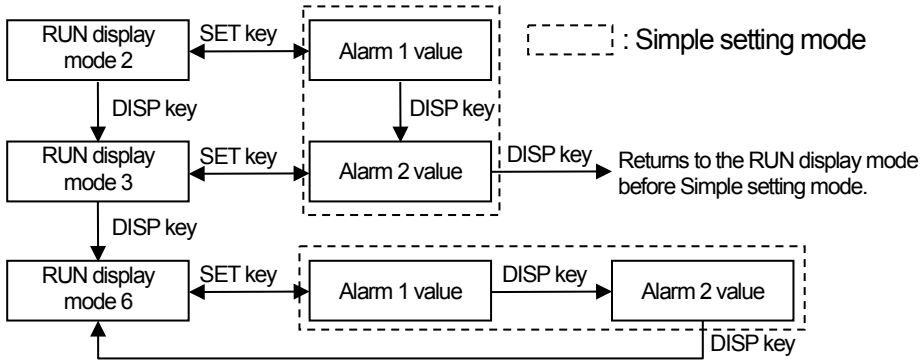

6.2 Display Transition for 4-outputs

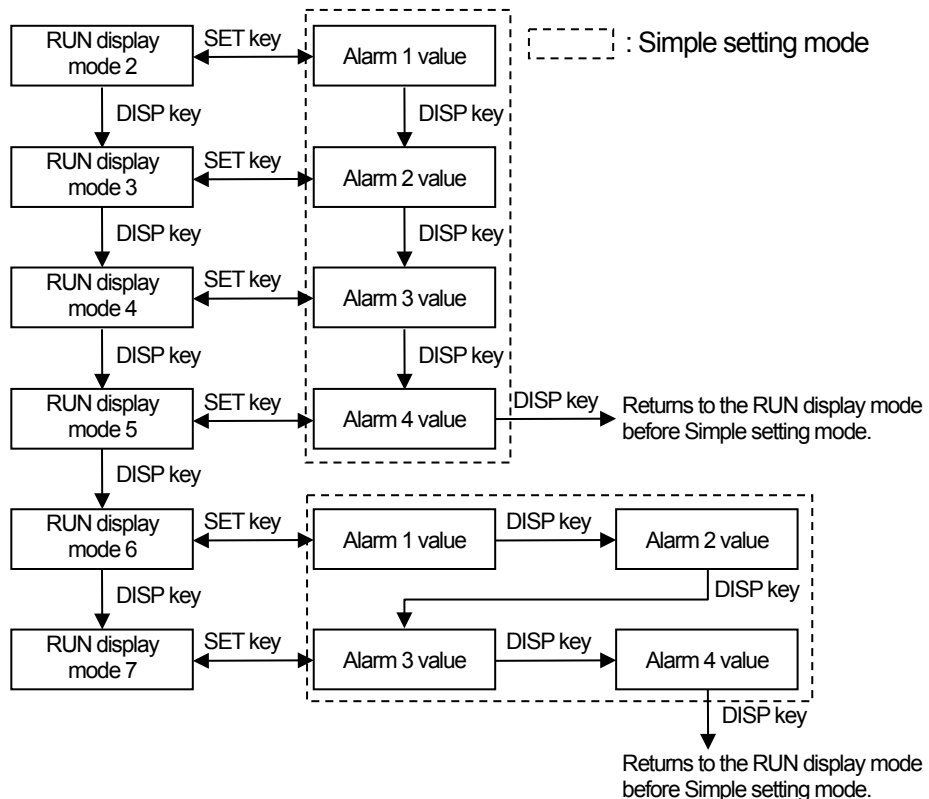

7. Setting Mode

7.1 Display Transition in Setting Mode

- [Dashed box icon]: Available only for 4-outputs spec.
- If the SET key is pressed and held down for approx. 5 seconds in each setting mode, the unit will move to the Default Display.

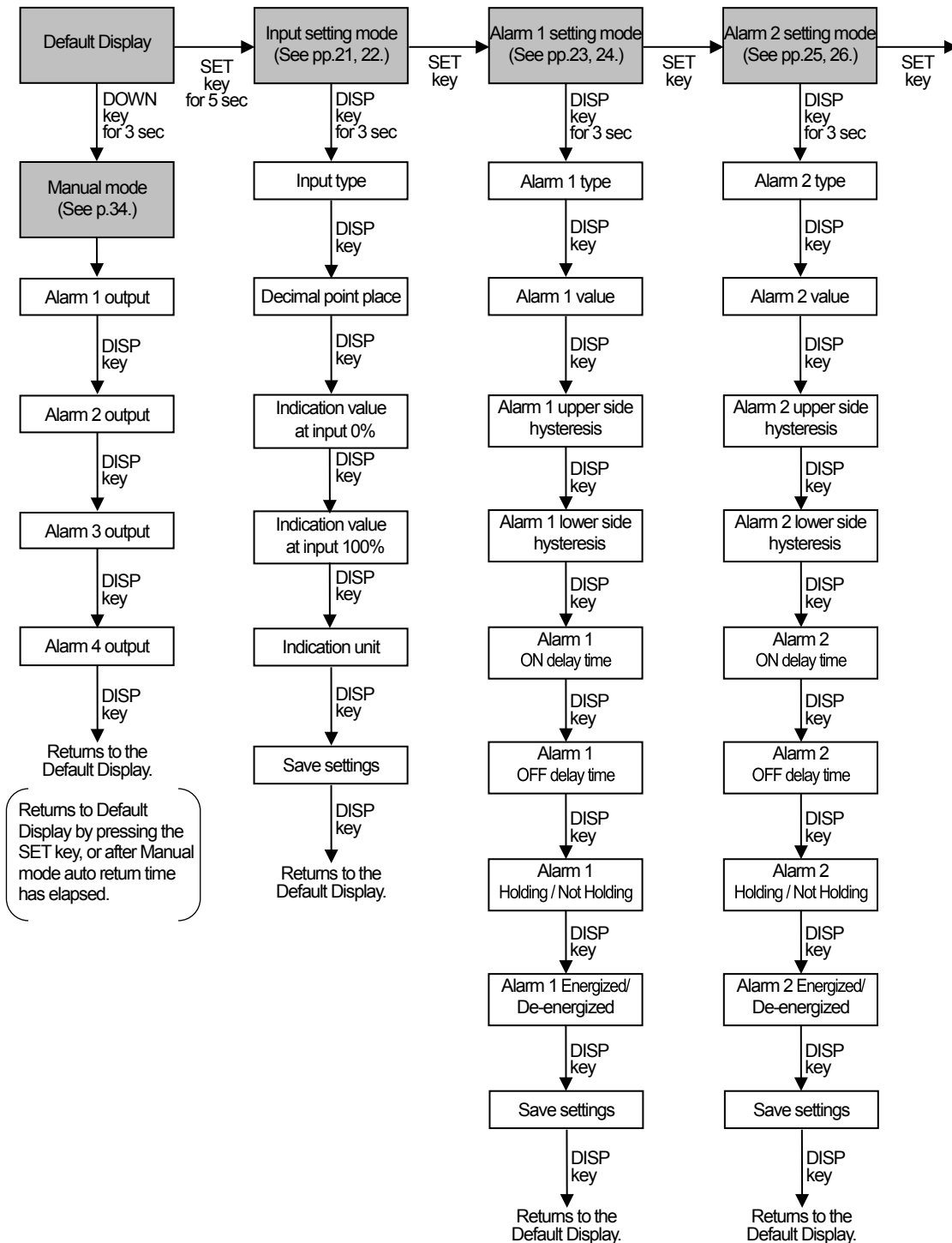

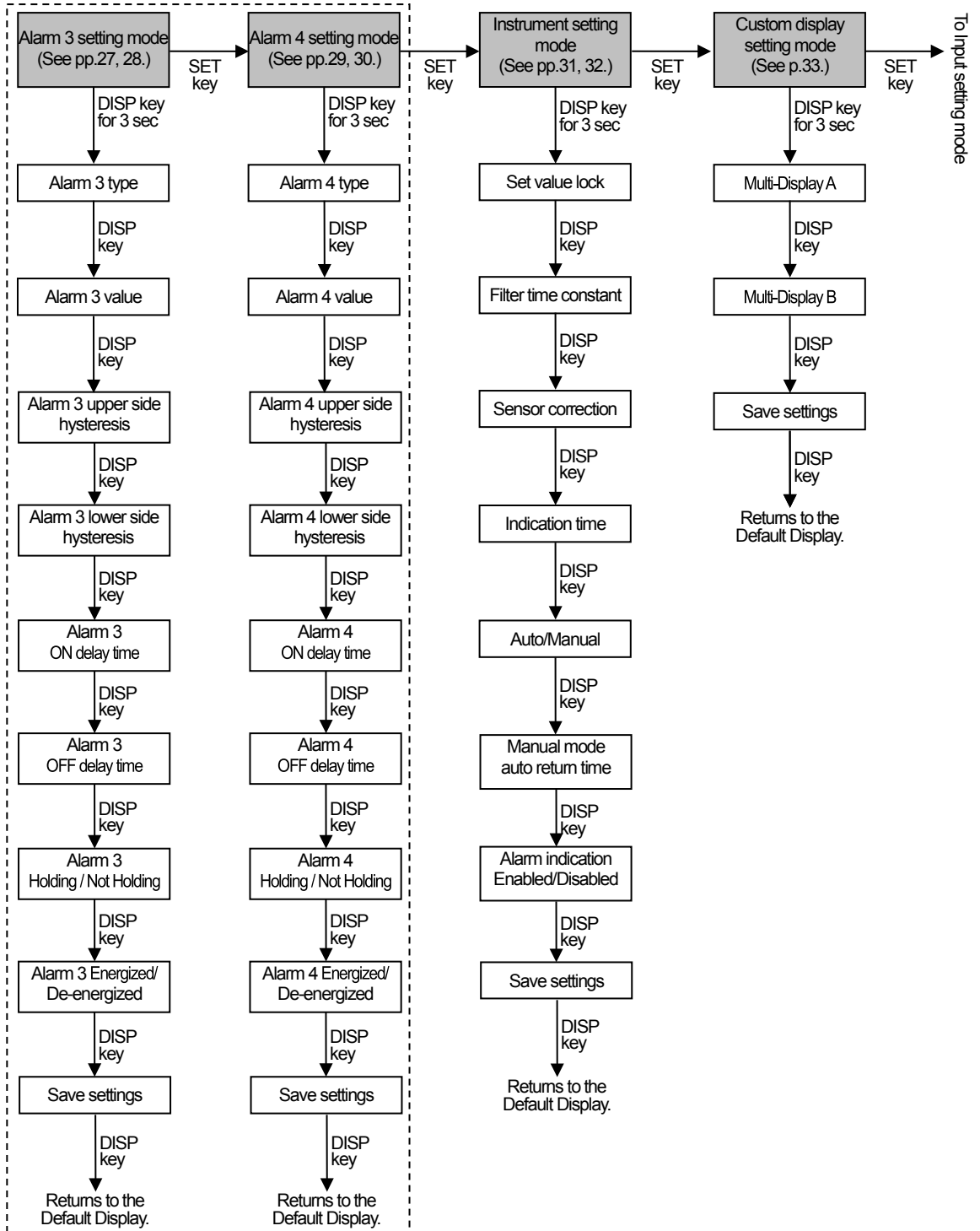

7.2 Input Setting Mode

Input Type

Selects an input type.

Setting Range	Indication		Factory Default
	Multi-Display A	Multi-Display B	
4 to 20 mA (Built-in 50 Ω shunt resistor)	SENS	420A	4 to 20 mA (Built-in 50 Ω shunt resistor) SENS 420A
4 to 20 mA (Externally mounted 250 Ω shunt resistor)		420V	
4 to 20 mA (Externally mounted 50 Ω shunt resistor)		420E	
1 to 5 V		115V	

Decimal Point Place

Selects a decimal point place.

Setting Range	Indication		Factory Default
	Multi-Display A	Multi-Display B	
No decimal point	2A00	2000	2 digits after decimal point 2A00 2000
1 digit after decimal point		2000	
2 digits after decimal point		2000	
3 digits after decimal point		2000	

Indication Value at Input 0%

Sets an indication value at the time of input 0%.

Setting Range	Indication		Factory Default
	Multi-Display A	Multi-Display B	
Low limit of each input type to [Indication value at input 100%]	0000	Set value	4.00 0000 4000

Indication Value at Input 100%

Sets an indication value at the time of input 100%.

Setting Range	Indication		Factory Default
	Multi-Display A	Multi-Display B	
[Indication value at input 0%] to High limit of each input type	0000	Set value	20.00 0000 2000

Indication Unit

Selects a unit for indication.

Setting Range	Indication		Factory Default
	Multi-Display A	Multi-Display B	
No unit	UNNE	NONE	No unit UNNE NONE
%		PERN	
mA		MANE	
V		VOLE	
$^{\circ}$ C		CELS	

Save Settings

Selects whether the settings are saved (registered) or not.

Setting Range	Indication		Factory Default
	Multi-Display A	Multi-Display B	
Save	SAVE	YES	Save SAVE YES
Not save		NO	

7.3 Alarm 1 Setting Mode

Alarm 1 Type

Selects Alarm 1 type.

Setting Range	Indication		Factory Default
	Multi-Display A	Multi-Display B	
No alarm action	ALNF	----	No alarm action ALNF ----
High limit alarm		HHXX	
Low limit alarm		LLXX	
High limit with standby alarm		HHXX	
Low limit with standby alarm		LLXX	

Alarm 1 Value

Sets Alarm 1 value.

Setting Range	Indication		Factory Default
	Multi-Display A	Multi-Display B	
[Indication value at input 0%] to [Indication value at input 100%]	ALXX	Set value	Indication value at input 0% ALXX XXXX

Alarm 1 Upper Side Hysteresis

Sets Alarm 1 upper side hysteresis from Alarm 1 value.

Setting Range	Indication		Factory Default
	Multi-Display A	Multi-Display B	
0 to 9999 (The placement of the decimal point follows the selection)	ALFX	Set value	0.00 ALFX XXXX

Alarm 1 Lower Side Hysteresis

Sets Alarm 1 lower side hysteresis from Alarm 1 value.

Setting Range	Indication		Factory Default
	Multi-Display A	Multi-Display B	
0 to 9999 (The placement of the decimal point follows the selection)	ALFX	Set value	0.00 ALFX XXXX

Alarm 1 ON Delay Time

Sets delay time when Alarm 1 is ON.

Setting Range	Indication		Factory Default
	Multi-Display A	Multi-Display B	
0 to 9999	ALFX	Set value	0 ALFX XXXX

Alarm 1 OFF Delay Time

Sets delay time when Alarm 1 is OFF.

Setting Range	Indication		Factory Default
	Multi-Display A	Multi-Display B	
0 to 9999	0000	Set value	0 0000 0000

Alarm 1 Holding/Not Holding

Selects either Holding or Not holding for Alarm 1.

Setting Range	Indication		Factory Default
	Multi-Display A	Multi-Display B	
Not Holding	HOLD	NONE	Not Holding
Holding		HOLD	HOLD NONE

Alarm 1 Energized/De-energized

Selects Alarm 1 action Energized/De-energized.

Setting Range	Indication		Factory Default
	Multi-Display A	Multi-Display B	
Energized	ALMS	NONE	Energized
De-energized		REVS	ALMS NONE

Save Settings

Selects whether the settings are saved (registered) or not.

Setting Range	Indication		Factory Default
	Multi-Display A	Multi-Display B	
Save	SAVE	YES	Save
Not save		NONE	SAVE YES

7.4 Alarm 2 Setting Mode

Alarm 2 Type

Selects Alarm 2 type.

Setting Range	Indication		Factory Default
	Multi-Display A	Multi-Display B	
No alarm action	AL2F	----	No alarm action AL2F ----
High limit alarm		HHXX	
Low limit alarm		LLXX	
High limit with standby alarm		HHXW	
Low limit with standby alarm		LLXW	

Alarm 2 Value

Sets Alarm 2 value.

Setting Range	Indication		Factory Default
	Multi-Display A	Multi-Display B	
[Indication value at input 0%] to [Indication value at input 100%]	ALM2	Set value	Indication value at input 0% ALM2 400

Alarm 2 Upper Side Hysteresis

Sets Alarm 2 upper side hysteresis from Alarm 2 value.

Setting Range	Indication		Factory Default
	Multi-Display A	Multi-Display B	
0 to 9999 (The placement of the decimal point follows the selection)	HNFL	Set value	0.00 HNFL 000

Alarm 2 Lower Side Hysteresis

Sets Alarm 2 lower side hysteresis from Alarm 2 value.

Setting Range	Indication		Factory Default
	Multi-Display A	Multi-Display B	
0 to 9999 (The placement of the decimal point follows the selection)	HNFL	Set value	0.00 HNFL 000

Alarm 2 ON Delay Time

Sets delay time when Alarm 2 is ON.

Setting Range	Indication		Factory Default
	Multi-Display A	Multi-Display B	
0 to 9999	ONNS	Set value	0 ONNS 000

Alarm 2 OFF Delay Time

Sets delay time when Alarm 2 is OFF.

Setting Range	Indication		Factory Default
	Multi-Display A	Multi-Display B	
0 to 9999		Set value	0

Alarm 2 Holding/Not Holding

Selects either Holding or Not holding for Alarm 2.

Setting Range	Indication		Factory Default
	Multi-Display A	Multi-Display B	
Not Holding			Not Holding
Holding			

Alarm 2 Energized/De-energized

Selects Alarm 2 action Energized/De-energized.

Setting Range	Indication		Factory Default
	Multi-Display A	Multi-Display B	
Energized			Energized
De-energized			

Save Settings

Selects whether the set contents are saved (registered) or not.

Setting Range	Indication		Factory Default
	Multi-Display A	Multi-Display B	
Save			Save
Not save			

7.5 Alarm 3 Setting Mode

Available only for 4-output spec.

Alarm 3 Type

Selects Alarm 3 type.

Setting Range	Indication		Factory Default
	Multi-Display A	Multi-Display B	
No alarm action	ALBF	----	No alarm action ALBF ----
High limit alarm		HH--	
Low limit alarm		LL--	
High limit with standby alarm		HHW	
Low limit with standby alarm		LLW	

Alarm 3 Value

Sets Alarm 3 value.

Setting Range	Indication		Factory Default
	Multi-Display A	Multi-Display B	
[Indication value at input 0%] [Indication value at input 100%]	ALMB	Set value	Indication value at input 0% ALMB 400

Alarm 3 Upper Side Hysteresis

Sets Alarm 3 upper side hysteresis from Alarm 3 value.

Setting Range	Indication		Factory Default
	Multi-Display A	Multi-Display B	
0 to 9999 (The placement of the decimal point follows the selection)	ALFU	Set value	0.00 ALFU 000

Alarm 3 Lower Side Hysteresis

Sets Alarm 3 lower side hysteresis from Alarm 3 value.

Setting Range	Indication		Factory Default
	Multi-Display A	Multi-Display B	
0 to 9999 (The placement of the decimal point follows the selection)	ALFL	Set value	0.00 ALFL 000

Alarm 3 ON Delay Time

Sets delay time when Alarm 3 is ON.

Setting Range	Indication		Factory Default
	Multi-Display A	Multi-Display B	
0 to 9999	ONND	Set value	0 ONND 000

Alarm 3 OFF Delay Time

Sets delay time when Alarm 3 is OFF.

Setting Range	Indication		Factory Default
	Multi-Display A	Multi-Display B	
0 to 9999	OFF	Set value	0 OFF

Alarm 3 Holding/Not Holding

Selects either Holding or Not holding for Alarm 3.

Setting Range	Indication		Factory Default
	Multi-Display A	Multi-Display B	
Not holding	HOLD	NONE	Not holding HOLD NONE
Holding		HOLD	

Alarm 3 Energized/De-energized

Selects Alarm 3 action Energized/De-energized.

Setting Range	Indication		Factory Default
	Multi-Display A	Multi-Display B	
Energized	ALMS	NONE	Energized ALMS NONE
De-energized		REKS	

Save Settings

Selects whether the set contents are saved (registered) or not.

Setting Range	Indication		Factory Default
	Multi-Display A	Multi-Display B	
Save	SAVE	YES	Save SAVE YES
Not save		NONE	

7.6 Alarm 4 Setting Mode

Available only for 4-output spec.

Alarm 4 Type

Selects Alarm 4 type.

Setting Range	Indication		Factory Default
	Multi-Display A	Multi-Display B	
No alarm action	AL4F	----	No alarm action AL4F ----
High limit alarm		HHXX	
Low limit alarm		LLXX	
High limit with standby alarm		HHXX	
Low limit with standby alarm		LLXX	

Alarm 4 Value

Sets Alarm 4 value.

Setting Range	Indication		Factory Default
	Multi-Display A	Multi-Display B	
[Indication value at input 0%] [Indication value at input 100%]	AL4H	Set value	Indication value at input 0% AL4H 400

Alarm 4 Upper Side Hysteresis

Sets Alarm 4 upper side hysteresis from Alarm 4 value.

Setting Range	Indication		Factory Default
	Multi-Display A	Multi-Display B	
0 to 9999 (The placement of the decimal point follows the selection)	414U	Set value	0.00 414U 000

Alarm 4 Lower Side Hysteresis

Sets Alarm 4 lower side hysteresis from Alarm 4 value.

Setting Range	Indication		Factory Default
	Multi-Display A	Multi-Display B	
0 to 9999 (The placement of the decimal point follows the selection)	414L	Set value	0.00 414L 000

Alarm 4 ON Delay Time

Sets delay time when Alarm 4 is ON.

Setting Range	Indication		Factory Default
	Multi-Display A	Multi-Display B	
0 to 9999	414D	Set value	0 414D 000

Alarm 4 OFF Delay Time

Sets delay time when Alarm 4 is OFF.

Setting Range	Indication		Factory Default
	Multi-Display A	Multi-Display B	
0 to 9999	0000	Set value	0 0000

Alarm 4 Holding/Not Holding

Selects either Holding or Not holding for Alarm 4.

Setting Range	Indication		Factory Default
	Multi-Display A	Multi-Display B	
Not Holding	H000	NONE	Not Holding H000 NONE
Holding		HOLD	

Alarm 4 Energized/De-energized

Selects Alarm 4 action Energized/De-energized.

Setting Range	Indication		Factory Default
	Multi-Display A	Multi-Display B	
Energized	ALMS	NONE	Energized ALMS NONE
De-energized		REMS	

Save Settings

Selects whether the set contents are saved (registered) or not.

Setting Range	Indication		Factory Default
	Multi-Display A	Multi-Display B	
Save	SAVE	YES	Save SAVE YES
Not save		NONE	

7.7 Instrument Setting Mode

Set Value Lock

Unlock, Lock 1, Lock 2 can be selected for the set values.

Setting Range	Indication		Factory Default
	Multi-Display A	Multi-Display B	
Unlock	LOCK	NONE	Unlock LOCK NONE
Lock 1 *1		LOCK	
Lock 2 *2		LOCK	

*1: Locks all set values.

*2: Locks all set values except alarm value.

Filter Time Constant

Sets input filter time constant.

Input fluctuation due to noise can be reduced.

Setting Range	Indication		Factory Default
	Multi-Display A	Multi-Display B	
0.0 to 10.0 sec	TIME	Set value	0.0 sec TIME 00

Sensor Correction

Sets sensor correction value.

Input value = Current input value + (Sensor correction value)

Setting Range	Indication		Factory Default
	Multi-Display A	Multi-Display B	
-1000 to 1000 *	0000	Set value	0.00 0000 0000

* The placement of the decimal point follows the selection.

Indication Time

Sets duration from no operation until Multi-Display A, Multi-Display B and each action indicator are turned off.

They remain lit during a setting mode, active alarm action, input errors or input disconnection.

When the value is set to 00.00, they remain lit.

After indication time has elapsed, and if any key is pressed while they are unlit, they will light up again.

Setting Range	Indication		Factory Default
	Multi-Display A	Multi-Display B	
00 : 00 to 60 : 00 (Minutes : Seconds) 00 : 00..... Continuous 00 : 01 to 60 : 00 Indication time	TIME	Set value	30 : 00 (Minutes : Seconds) TIME 0000

Auto/Manual

If AUTO is selected, the alarm will be output corresponding to the alarm value.

When MANUAL is selected, the unit enters Manual mode. Any alarm (from Alarm 1 to Alarm 4 output) selected in Manual mode will be output.

Setting Range	Indication		Factory Default
	Multi-Display A	Multi-Display B	
Auto	MARS	ALRS	Manual MARS MANU
Manual		MANU	

Manual Mode Auto Return Time

Sets duration from manual mode until the unit automatically returns to Default Display.

When set to 0 (zero), auto return does not occur.

Setting Range	Indication		Factory Default
	Multi-Display A	Multi-Display B	
0 to 60 minutes	MORL	Set value	30 minutes MORL XX:XX

Alarm Indication Enabled/Disabled

In any display mode except All unlit display mode, when any alarm is active, alarm (from ALMM to ALMH) indication Enabled/Disabled can be selected.

Setting Range	Indication		Factory Default
	Multi-Display A	Multi-Display B	
Disabled	ALRS	NONE	Disabled ALRS NONE
Enabled		ALRS	

Save Settings

Selects whether the set contents are saved (registered) or not.

Setting Range	Indication		Factory Default
	Multi-Display A	Multi-Display B	
Save	SAVE	YESX	Save SAVE YESX
Not save		NONE	

7.8 Custom Display Setting Mode

Customizes characters to be indicated on the Multi-Display A and B (*).

Use alphanumeric characters and symbols.

(e.g.) FLOW, TEMP, No.1, No.2

(*) Number of characters which can be indicated differs depending on display mode.

Refer to Section '5. Display Mode'.



- If Custom display mode 1 is selected:
Up to 8 characters can be displayed in total for both Multi-Display A and B.
- If Custom display mode 2 is selected:
Up to 4 characters can be displayed on the Multi-Display B.

Can be set from the thousands digit of the display.

Digits can be selected with the SET key.



Multi-Display A

Characters for the Multi-Display A can be customized.

Setting Range	Indication		Factory Default
	Multi-Display A	Multi-Display B	
A to Z, 0 to 9, /, -, ., (Blank)		Set value	AAAA 





Multi-Display B

Characters for the Multi-Display B can be customized.

Setting Range	Indication		Factory Default
	Multi-Display A	Multi-Display B	
A to Z, 0 to 9, /, -, ., (Blank)		Set value	AAAA 

Save Settings

Selects whether the set contents are saved (registered) or not.

Setting Range	Indication		Factory Default
	Multi-Display A	Multi-Display B	
Save			Save 
Not save			

7.9 Manual Mode

If MANUAL is selected in [Auto/Manual] in Instrument setting mode, and if ON is selected in [Alarm 1 output] to [Alarm 4 output], then the alarm output will be activated.

By using the DISP key, each alarm output can be selected.

Only when MANUAL is selected in [Auto/Manual] in Instrument setting mode, the unit can enter Manual mode.

- ① Press the DOWN key for 3 seconds in Default Display. The unit enters Manual mode. [Alarm 1 output] (ALARM) appears.
- ② ON/OFF can be switched by the UP or DOWN key.
- ③ Press the DISP key to enter [Alarm 2 output] (ALARM).
- ④ ON/OFF can be switched by the UP or DOWN key.
- ⑤ Press the DISP key to enter [Alarm 3 output] (ALARM).
- ⑥ ON/OFF can be switched by the UP or DOWN key.
- ⑦ Press the DISP key to enter [Alarm 4 output] (ALARM).
- ⑧ ON/OFF can be switched by the UP or DOWN key.
- ⑨ Press the DISP key to return to Default Display.

The unit returns to Default Display by pressing the SET key, or after Manual mode auto return time has elapsed.

8. Operation

8.1 Indication after power is turned ON

After the power is turned ON, the unit enters warm-up status for approx. 3 seconds. Multi-Display A indicates a model name, and Multi-Display B indicates Input and Output code.
(e.g.) SGAL-A02A-0-0

Multi-Display A: 

Multi-Display B: 

8.2 Alarm 1 to Alarm 4 Value Setting

Sets Alarm 1 value to Alarm 4 value.

8.2.1 Basic Operation for Setting Alarm 1 to Alarm 4 Value

Alarm 1 value to Alarm 4 value can be set in Simple setting mode.

These setting items are the same as those in Alarm 1 to Alarm 4 setting mode.

To enter Simple setting mode, follow the procedure below.





(e.g.) Any alarm type (except No alarm action) is selected in [Alarm 1 type] to [Alarm 4 type].
Default Display is RUN display mode 1.

- ① Press the DISP key.
The unit enters RUN display mode 2.
Multi-Display A indicates an input value, and Multi-Display B indicates Alarm 1 value.
- ② Press the SET key.
The unit enters Simple setting mode.
Multi-Display A indicates , and Multi-Display B flashes Alarm 1 value.
- ③ Set the alarm value with the SHIFT, UP, or DOWN key, and press the DISP key.
Alarm 1 value will be saved (registered), and the unit moves to [Alarm 2 value].
- ④ Set Alarm 2 to Alarm 4 value in the same manner.
- ⑤ Press the DISP key at [Alarm 4 value].
The unit reverts to RUN display mode 2.

8.2.2 Alarm 1 to Alarm 4 Value

Alarm 1 to Alarm 4 value are shown below.

Refer to the following to set alarm values.

Indication		Setting Item, Function, Setting Range
Multi-Display A	Multi-Display B	
	Alarm 1 value flashes.	Alarm 1 value Sets Alarm 1 value. Setting Range: [Indication value at input 0%] to [Indication value at input 100%]
	Alarm 2 value flashes.	Alarm 2 value Sets Alarm 2 value. Setting Range: [Indication value at input 0%] to [Indication value at input 100%]
	Alarm 3 value flashes.	Alarm 3 value Sets Alarm 3 value. Setting Range: [Indication value at input 0%] to [Indication value at input 100%]
	Alarm 4 value flashes.	Alarm 4 value Sets Alarm 4 value. Setting Range: [Indication value at input 0%] to [Indication value at input 100%]

8.3 Operation

8.3.1 Alarm Output Indication

Alarm output indication differs depending on display mode.

Refer to '5. Display Mode'.

When ENABLED is selected in [Alarm indication Enabled/Disabled], the following characters are displayed when each alarm output is ON.

Indication		Setting Item, Function, Setting Range
Multi-Display A	Multi-Display B	
ALM1	Follows the display mode.	Alarm 1 output ON
ALM2	Follows the display mode.	Alarm 2 output ON
ALM3	Follows the display mode.	Alarm 3 output ON
ALM4	Follows the display mode.	Alarm 4 output ON

When multiple alarms are ON, the smallest alarm number will be displayed.

8.3.2 Input Indication Range

The input value is displayed within the following range:

[Indication value at input 0% – (Indication value at input 100% – Indication value at input 0%) x 10%] to

[Indication value at input 100% + (Indication value at input 100% – Indication value at input 0%) x 10%]

For a value lower than (and including) -2000, the minus (-) sign and the input value light up alternately.

For a value higher than (and including) 10000, the lower 4 digits flash.

(The placement of the decimal point follows the selection.)

When input value exceeds the indication range:  flashes.

When input value drops below the indication range:  flashes.

8.3.3 Input Disconnection

If input is disconnected, the input status will become as follows.

Input	Input Status
4 to 20mA (Built-in 50 Ω shunt resistor)	Equals 0 mA input.
4 to 20mA (Externally mounted 250 Ω shunt resistor)	Equals 0 mA input.
4 to 20mA (Externally mounted 50 Ω shunt resistor)	Equals 0 mA input.*
1 to 5V	Equals 0 V input.

If the indication is overscale, the Alarm indicator will light up, and  will flash.

* If the shunt resistor is out of order or disconnected, the indication will be overscale.

8.3.4 Indication Time Setting

After preset indication time has elapsed, Multi-Display A, Multi-Display B and each action indicator are turned OFF.

They will light up again if any alarm is activated, or if any key is pressed.

They remain lit during a setting mode, when an alarm action is ON, or if input errors or input disconnection occurs.

If the indication time is set to 00:00, they will remain lit.

9. Specifications

Input Specifications

Direct current input	Input Range	Shunt Resistor	Indication Resolution
	4 to 20 mA DC	50 Ω *	1
		250 Ω	1
		50 Ω	1
* Built-in shunt resistor			
DC voltage input	Input Range	Input Resistance	Indication Resolution
	1 to 5 V	1 MΩ	1

Output 1, Output 2 Specifications

Relay contact	1a or 1b
Control capacity	3 A 250 V AC (Resistive load) 1 A 250 V AC (Inductive load $\cos \phi = 0.4$) Electrical life: 100,000 cycles Minimum applicable load: 10 mA 5 V DC

Performance

Base accuracy (at 25°C)	± 0.1% of each input span
Temperature coefficient	± 0.015 %/°C
Response time	500 ms max. (0→90%)
Indication update cycle	125 ms
Indication accuracy	± 0.1% of each input span ± 1 digit

General Structure

Dimensions	22.5 x 89 x 70 mm (W x H x D)
Weight	2-outputs: Approx. 88 g (Excluding socket) 4-outputs: Approx. 96.2 g (Excluding socket)
Mounting method	DIN rail
Case	Flame-resistant resin, Color: Black
Front panel	Polycarbonate

Installation Specifications

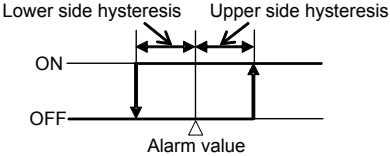
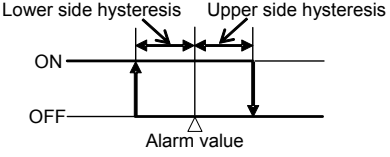
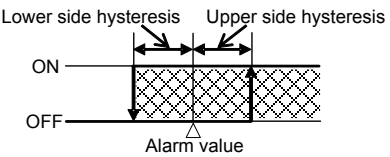
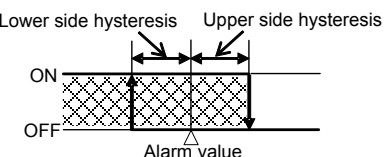

Supply voltage	100 to 240 V AC 50/60 Hz
Allowable voltage range	85 to 264 V AC
Power consumption	2-outputs: Approx. 8 VA max. 4-outputs: Approx. 10 VA max.
Ambient temperature	-10 to 55°C (Non-condensing, no icing)
Ambient humidity	35 to 85 %RH (Non-condensing)

Standard Function

Power failure countermeasure	The setting data is backed up in the non-volatile IC memory.																		
Self-diagnosis	The CPU is monitored by a watchdog timer, and if an abnormal status occurs, the unit is switched to warm-up status, turning all outputs OFF.																		
Alarm 1 type Alarm 2 type Alarm 3 type Alarm 4 type	<p>High limit alarm, Low limit alarm, High limit with standby alarm, Low limit with standby alarm, No alarm action can be selected. (Factory default: No alarm action)</p> <p>If High limit alarm is selected in [Alarm 1 type], and if Energized is selected in [Alarm 1 Energized/De-energized], alarm output will be turned ON when input exceeds Alarm 1 value.</p> <p>If De-energized is selected in [Alarm 1 Energized/De-energized], alarm output will be turned OFF.</p> <table border="1" data-bbox="498 568 1146 774"> <thead> <tr> <th></th> <th></th> <th>Energized</th> <th>De-energized</th> </tr> </thead> <tbody> <tr> <td rowspan="2">a contact</td> <td>Alarm indicator</td> <td>Lights</td> <td>Lights</td> </tr> <tr> <td>Alarm 1 output</td> <td>ON</td> <td>OFF</td> </tr> <tr> <td rowspan="2">b contact</td> <td>Alarm indicator</td> <td>Lights</td> <td>Lights</td> </tr> <tr> <td>Alarm 1 output</td> <td>OFF</td> <td>ON</td> </tr> </tbody> </table> <ul style="list-style-type: none"> • High limit alarm  • Low limit alarm  • High limit with standby alarm  • Low limit with standby alarm  <p>Setting accuracy: Same as Base accuracy Output action: ON/OFF action</p>			Energized	De-energized	a contact	Alarm indicator	Lights	Lights	Alarm 1 output	ON	OFF	b contact	Alarm indicator	Lights	Lights	Alarm 1 output	OFF	ON
		Energized	De-energized																
a contact	Alarm indicator	Lights	Lights																
	Alarm 1 output	ON	OFF																
b contact	Alarm indicator	Lights	Lights																
	Alarm 1 output	OFF	ON																
Set value lock	Lock 1: None of the set values can be changed. Lock 2: Only alarm value can be changed. The others cannot be changed.																		

10. Troubleshooting

10.1 Indication

Problem	Possible Cause	Solution
Multi-Display A or B flashes  or  when input value is indicated.	The sensor may be disconnected.	Replace with a new sensor.
	Check whether the input terminals of this instrument are securely mounted to the sensor.	Connect the sensor terminals to the instrument input terminals securely.
	Check the input signal source.	Ensure that the input signal source works normally.
Multi-Display A or B is irregular or unstable when input value is indicated.	Check whether sensor input is correct.	Select the same sensor type as that of currently used sensor.
	Sensor correction value is unsuitable.	Set it to a suitable value.
	AC leaks into the sensor circuit.	Use an ungrounded type sensor.
There may be equipment that interferes with or makes noise near the instrument.		Keep the instrument clear of any potentially disruptive equipment.
Displays and indicators are unlit. If any key is pressed, they will light up.	The Indication Time (p.31) is set to any value other than 00 : 00. (Factory default is 30 : 00.)	To indicate continuously, set the Indication Time (p.31) to "00 : 00".

10.2 Key Operation

Problem	Possible Cause	Solution
If the DISP key is pressed, Multi-Display A shows  , and the display mode cannot be switched.	The DISP key is in locked status.	Press the DISP key for approx. 3 seconds to release the key lock.

10.3 Operation

Problem	Possible Cause	Solution
When Multi-Display A or B indicates an input value, the input value does not change.	The sensor may be out of order.	Replace with the new sensor.
	Check whether input and output wires are securely connected to the I/O terminals of the instrument.	Ensure that input and output wires are securely connected to the I/O terminals of the instrument.
	Check whether the wiring of input and output are correct.	Wire them correctly.
No alarm output	Check whether Alarm 1 value to Alarm 4 value are suitable. (p.35)	Set them to suitable values.

11. Character Table

Please use the following factory default values for your reference.

Display Mode

Setting Item	Multi-Display A	Multi-Display B	Data
Default Display mode	Follows currently indicated display mode.		
RUN display mode 1	Input value	Unlit	
RUN display mode 2	Input value	Alarm 1 value	
RUN display mode 3	Input value	Alarm 2 value	
RUN display mode 4 *	Input value	Alarm 3 value	
RUN display mode 5 *	Input value	Alarm 4 value	
RUN display mode 6	Alarm 1 value	Alarm 2 value	
RUN display mode 7 *	Alarm 3 value	Alarm 4 value	
Custom display mode 1	AAAA	AAAA	
Custom display mode 2	Input value	AAAA	
Unlit display mode	Unlit	Unlit	
All unlit display mode	Unlit	Unlit	
Model display mode	Model	Input, Output code	

* Available only for 4-outputs spec.

Setting Mode

Setting Item	Multi-Display A	Multi-Display B	Data
Input setting mode	INNM	Unlit	
Alarm 1 setting mode	ALM1	Unlit	
Alarm 2 setting mode	ALM2	Unlit	
Alarm 3 setting mode *	ALM3	Unlit	
Alarm 4 setting mode *	ALM4	Unlit	
Instrument setting mode	INNM	Unlit	
Custom display setting mode	DISP	Unlit	

* Available only for 4-outputs spec.

Input Setting Mode

Setting Item	Multi-Display A	Multi-Display B	Data
Input type	SENS	420A	
Decimal point place	1000	1000	
Indication value at input 0%	0000	0400	
Indication value at input 100%	0000	2000	
Indication unit	UNNE	UNNE	
Save settings	SAVE	YES	

Alarm 1 Setting Mode

Setting Item	Multi-Display A	Multi-Display B	Data
Alarm 1 type	ALMF	FFFF	
Alarm 1 value	ALM1	4000	
Alarm 1 upper side hysteresis	UMFU	0000	
Alarm 1 lower side hysteresis	LMFL	0000	
Alarm 1 ON delay time	ON04	0000	
Alarm 1 OFF delay time	OF04	0000	
Alarm 1 Holding/Not Holding	H0SE	NONE	
Alarm 1 Energized/De-energized	ALMS	NOML	
Save settings	SAVE	YES	

Alarm 2 Setting Mode

Setting Item	Multi-Display A	Multi-Display B	Data
Alarm 2 type	ALBF	FFFF	
Alarm 2 value	ALM2	4000	
Alarm 2 upper side hysteresis	UMFU	0000	
Alarm 2 lower side hysteresis	LMFL	0000	
Alarm 2 ON delay time	ON04	0000	
Alarm 2 OFF delay time	OF04	0000	
Alarm 2 Holding/Not Holding	H0SE	NONE	
Alarm 2 Energized/De-energized	ALMS	NOML	
Save settings	SAVE	YES	

Alarm 3 Setting Mode (Available only for 4-outputs spec)

Setting Item	Multi-Display A	Multi-Display B	Data
Alarm 3 type	ALBF	FFFF	
Alarm 3 value	ALM3	4000	
Alarm 3 upper side hysteresis	UMFU	0000	
Alarm 3 lower side hysteresis	LMFL	0000	
Alarm 3 ON delay time	ON04	0000	
Alarm 3 OFF delay time	OF04	0000	
Alarm 3 Holding/Not Holding	H0SE	NONE	
Alarm 3 Energized/De-energized	ALMS	NOML	
Save settings	SAVE	YES	

Alarm 4 Setting Mode (Available only for 4-outputs spec)

Setting Item	Multi-Display A	Multi-Display B	Data
Alarm 4 type	ALBF	FFFF	
Alarm 4 value	ALM4	4000	
Alarm 4 upper side hysteresis	UMFU	0000	
Alarm 4 lower side hysteresis	LMFL	0000	
Alarm 4 ON delay time	ON04	0000	
Alarm 4 OFF delay time	OF04	0000	
Alarm 4 Holding/Not Holding	H0SE	NONE	
Alarm 4 Energized/De-energized	ALMS	NOML	
Save settings	SAVE	YES	

Instrument Setting Mode

Setting Item	Multi-Display A	Multi-Display B	Data
Set value lock	LOCK	NONE	
Filter time constant	TIME	XXXX	
Sensor correction	SENS	XXXX	
Indication time	TIME	XXXX	
Auto/Manual	MANU	MANU	
Manual mode auto return time	MODE	XXXX	
Alarm indication Enabled/Disabled	ALMS	NONE	
Save settings	SAVE	YESX	

Custom Display Setting Mode

Setting Item	Multi-Display A	Multi-Display B	Data
Multi-Display A	ASAA	AAAA	
Multi-Display B	ASAB	AAAA	
Save settings	SAVE	YESX	

Manual Mode

Setting Item	Multi-Display A	Multi-Display B	Data
Alarm 1 output	AL1N	OFFX	
Alarm 2 output	AL2N	OFFX	
Alarm 3 output	AL3N	OFFX	
Alarm 4 output	AL4N	OFFX	

***** Inquiries *****

For any inquiries about this unit, please contact our agency or the vendor where you purchased the unit after checking the following.

[Example]

- Model ----- SGAL-A02A-0-0
- Serial number ----- No. 154F05000

In addition to the above, please let us know the details of the malfunction, or discrepancy, and the operating conditions.

SHINKO TECHNOS CO., LTD. OVERSEAS DIVISION

Head Office: 2-5-1, Senbahigashi, Minoo, Osaka, Japan

URL: <http://www.shinko-technos.co.jp/e/>

E-mail: overseas@shinko-technos.co.jp

Tel : +81-72-727-6100

Fax: +81-72-727-7006