

PLC INTERFACE UNIT

SIF-600

INSTRUCTION MANUAL

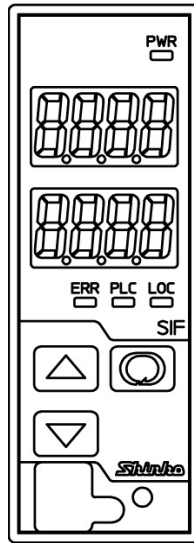

Shinko

Preface

Thank you for purchasing our SIF-600, PLC interface unit.

This manual contains instructions for the mounting, functions, operations and notes when operating the SIF-600. To ensure safe and correct use, thoroughly read and understand this manual before using this instrument. To prevent accidents arising from the misuse of this instrument, please ensure the operator receives this manual.

Notes

- This instrument should be used in accordance with the specifications described in the manual. If it is not used according to the specifications, it may malfunction or cause a fire.
- Be sure to follow all of the warnings, cautions and notices. If they are not observed, serious injury or malfunction may occur.
- The contents of this instruction manual are subject to change without notice.
- Care has been taken to assure that the contents of this instruction manual are correct, but if there are any doubts, mistakes or questions, please inform our sales department.
- This instrument is designed to be installed on a DIN rail within a control panel. If it is not, measures must be taken to ensure that the operator cannot touch power terminals or other high voltage sections.
- Any unauthorized transfer or copying of this document, in part or in whole, is prohibited.
- Shinko Technos CO., LTD. is not liable for any damage or secondary damage(s) incurred as a result of using this product, including any indirect damage.

Safety Precautions **(Be sure to read these precautions before using our products.)**

The safety precautions are classified into 2 categories: "Warning" and "Caution".

Depending on the circumstances, procedures indicated by  Caution may cause serious results, so be sure to follow the directions for usage.

Warning

Procedures which may lead to dangerous conditions and cause death or serious injury, if not carried out properly.

Caution

Procedures which may lead to dangerous conditions and cause superficial to medium injury or physical damage or may degrade or damage the product, if not carried out properly.

Warning

- To prevent an electric shock or fire, only Shinko or other qualified service personnel may handle the inner assembly.
- To prevent an electric shock, fire or damage to the instrument, parts replacement may only be undertaken by Shinko or other qualified service personnel.

SAFETY PRECAUTIONS

- To ensure safe and correct use, thoroughly read and understand this manual before using this instrument.
- This instrument is intended to be used for industrial machinery, machine tools and measuring equipment. Verify correct usage after purpose-of-use consultation with our agency or main office. (Never use this instrument for medical purposes with which human lives are involved.)
- External protection devices such as protective equipment against excessive temperature rise, etc. must be installed, as malfunction of this product could result in serious damage to the system or injury to personnel. Also proper periodic maintenance is required.
- This instrument must be used under the conditions and environment described in this manual. Shinko Technos Co., Ltd. does not accept liability for any injury, loss of life or damage occurring due to the instrument being used under conditions not otherwise stated in this manual.

Caution with respect to Export Trade Control Ordinance

To avoid this instrument from being used as a component in, or as being utilized in the manufacture of weapons of mass destruction (i.e. military applications, military equipment, etc.), please investigate the end users and the final use of this instrument.

In the case of resale, ensure that this instrument is not illegally exported.

1. Installation Precautions



Caution

This instrument is intended to be used under the following environmental conditions (IEC61010-1): Overvoltage category II, Pollution degree 2

Ensure the mounting location corresponds to the following conditions:

- A minimum of dust, and an absence of corrosive gases
- No flammable, explosive gases
- No mechanical vibrations or shocks
- No exposure to direct sunlight, an ambient temperature of 0 to 50 °C (32 to 122 °F) that does not change rapidly, and no icing
- An ambient non-condensing humidity of 35 to 85 %RH
- No large capacity electromagnetic switches or cables through which large current is flowing
- No water, oil or chemicals or where the vapors of these substances can come into direct contact with the unit
- If the SIF-600 is mounted within a control panel, the ambient temperature of the unit - not the ambient temperature of the control panel - must be kept to under 50 °C. Otherwise the life of electronic parts (especially electrolytic capacitors) of the unit will be shortened.

Note: Do not install this instrument on or near flammable material even though the case of this instrument is made of flame-resistant resin.

2. Wiring Precautions



Caution

- Do not leave wire remnants in the instrument, because they could cause a fire or a malfunction.
- Use a solderless terminal with an insulation sleeve in which the M3 screw fits when wiring the SIF-600.
- Tighten the terminal screw using the specified torque. If excessive force is applied to the screw when tightening, the terminal screw may be damaged.
- This instrument does not have a built-in power switch, circuit breaker or fuse.
Be sure to install a built-in power switch, circuit breaker or fuse near the instrument.
(Recommended fuse: Time-lag fuse, rated voltage 250 V AC, rated current 2 A)
- For a 24 V AC/DC power source, do not confuse polarity when using direct current (DC).

3. Operation and Maintenance Precautions



Warning

- Do not touch live terminals. This may cause electric shock or problems in operation.
- Turn the power supply to the instrument OFF before retightening the terminal or cleaning.
Working or touching the terminal with the power switched ON may result in severe injury or death due to electric shock.
- Use a soft, dry cloth when cleaning the instrument.
(Alcohol based substances may tarnish or deface the unit.)
- As the display section is vulnerable, do not strike or scratch it with a hard object or put pressure on it.

--- CONTENTS ---

1. Overview

1.1 Overview	6
1.2 Configuration	6
1.3 PLC Memory Allocation Method	7

2. Model

2.1 Model	8
2.2 How to Read the Model Label	8

3. Name and Functions of Sections 9

4. Mounting, Removal

4.1 Site Selection	10
4.2 External Dimensions (scale: mm)	10
4.3 Mounting	10
4.4 Removal	12

5. Wiring

5.1 Lead Wire Solderless Terminal	14
5.2 Terminal Arrangement	15
5.3 Connecting Power Terminals	15
5.4 Connecting to a PLC	
5.4.1 Connecting to a Mitsubishi PLC	16
5.4.2 Connecting to an Omron PLC	18
5.4.3 Connecting to a Keyence PLC	19
5.4.4 Connecting to a Yokogawa PLC	20
5.4.5 Connecting to a Fuji PLC	21
5.5 Connecting to Digital Indicating Controllers	
5.5.1 Connecting to the WCL-13A	22
5.5.2 Connecting to the DCL-33A	23
5.5.3 Connecting to the NCL-13A	24
5.5.4 Connecting to the ACx-13A, JCx-33A Series	25

6. Setup

6.1 Shifting to Each Mode of the SIF-600	26
6.1.1 Communication Mode	27
6.1.2 Console Software	27
6.1.3 Parameter Setting Mode	27
6.2 Setup via Console Software	27
6.2.1 Setup Using the Flexible Address Method	30
6.2.2 Setup Using the Multi Address Method	37
6.2.3 Setup Using the Flagless Method	44
6.2.4 Setup Using the Fixed Address Method	51
6.3 Setup in Parameter Setting Mode	58
6.3.1 Key Operation Flowchart in Parameter Setting Mode	59
6.3.2 Setting Items in Parameter Setting Mode	60

6.4 Setup of the PLC	
6.4.1 Setup of Mitsubishi PLC	63
6.4.2 Setup of Omron PLC	68
6.4.3 Setup of Keyence PLC	69
6.4.4 Setup of Yokogawa PLC	71
6.4.5 Setup of Fuji PLC	72
6.5 Setup of Digital Indicating Controllers	73
7. Operation	
7.1 Turn the Power ON	74
7.2 Flexible Address Method	
7.2.1 How to Read/Write Data on the PLC	76
7.2.2 Action Details and Notes	79
7.3 Multi Address Method	
7.3.1 How to Read/Write Data on the PLC	80
7.3.2 Action Details and Notes	83
7.4 Flagless Method	
7.4.1 How to Read/Write Data on the PLC	84
7.4.2 Action Details and Notes	91
7.5 Fixed Address Method	
7.5.1 How to Read/Write Data on the PLC	92
7.5.2 Action Details and Notes	97
8. Specifications	98
9. Troubleshooting	
9.1 Communication	101
9.2 Indication	101
10. Character Table	103

1. Overview

1.1 Overview

The SIF-600 is a PLC interface unit, which relays communication between a PLC and a maximum of 95 controllers (*).

The SIF-600 stores controllers' data in the PLC register, and exchanges data using Read/Write flag operation.

Digital indicating controllers equipped with Shinko protocol or Modbus protocol can be connected.

(*) When connecting 32 units or more, repeaters are necessary.

Shinko communication converter IF-400 can be used as a repeater.

1.2 Configuration

● Configuration without Using Repeaters

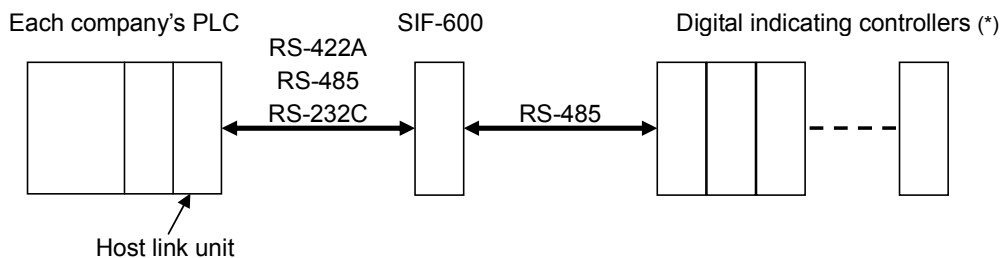

(*) A maximum of 31 controllers can be connected (For the Fixed address method: Max. 20 units).

(Fig. 1.2-1)

● Configuration Using Repeaters

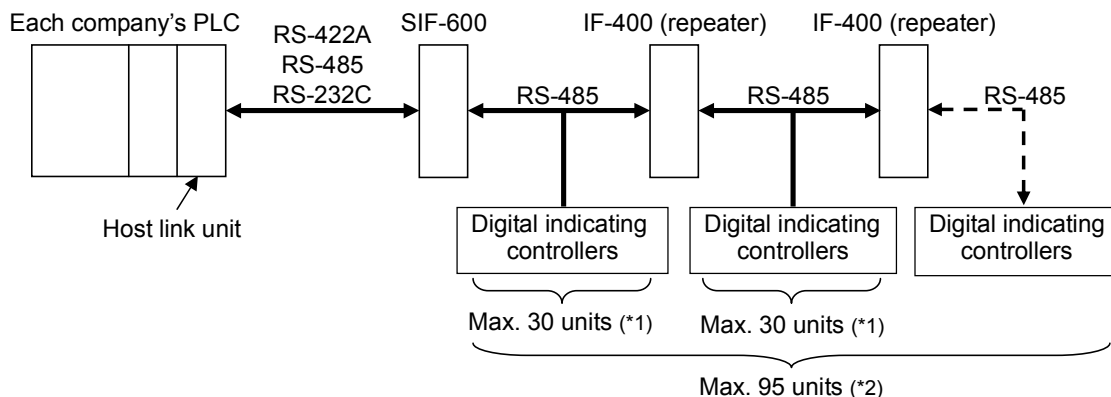

(*1): A maximum of 30 controllers can be connected with the IF-400 (repeater) as the 31st unit.

(*2): UP to 3 units of the IF-400 (repeater) and up to 95 controllers can be connected.

(Fig. 1.2-2)

PLCs Corresponding to SIF-600

PLC manufacturer	PLC model	Host link unit
Mitsubishi Electric Corp.	MELSEC Q series, QnA series (*)	AJ71UC24, A1SJ71UC24-R2/R4/PRF A1SJ71C24-R2/R4/PRF, QJ71C24
	MELSEC FX series (*)	—————
Omron Corp.	SYSMAC CJ series	CS1W-SCU21-V1 CJ1W-SCU21, CJ1W-SCU41
Keyence Corp.	KV	KV-L20V
Yokogawa Electric Corp.	FA-M3	F3LC11-2N, F3LC11-1F, F3LC12-1F
Fuji Electric Co., Ltd.	MICREX-SX series	NP1L-RS1, NP1L-RS2, NP1L-RS3, NP1L-RS4

(*) Models with compatible QR/QW communication commands

1.3 PLC Memory Allocation Method

There are 4 methods for PLC Memory allocation. (Factory default: Fixed Address method)

PLC memory allocation method	Contents
Flexible address method	Constantly updates RO (Read Only) data items. Settings of RW (Read/Write) data items are managed via the Set value change flag.
Multi address method	Block communication command (Multiple data communication command in Modbus protocol) is available. (*) Constantly updates RO (Read Only) data items. Settings of RW (Read/Write) data items are managed via the Set value change flag.
Flagless method	Constantly updates RO (Read Only) data items. RW (Read/Write) data items are managed without using the Set value change flag.
Fixed address method	PLC register section is fixed for 20 units. Constantly updates RO (Read Only) data items. Settings of RW (Read/Write) data items are managed via the Set value change flag.

(*) This method can be used for Shinko Multi-point temperature control system C series or Temperature control boards.

Advantages/Disadvantages of the PLC Memory Allocation Methods

PLC memory allocation method	Number of connectable controllers	Advantage	Disadvantage
Flexible address method	Max. 95 units	<ul style="list-style-type: none"> Number of PLC register addresses can be reduced since data items can be set randomly. 	<ul style="list-style-type: none"> Initial setup (*) of the PLC is required. PLC data addresses changes depending on increase/decrease of the number of controllers.
Multi address method	Max. 95 units	<ul style="list-style-type: none"> Number of PLC register addresses can be reduced since data items can be set randomly. Block communication command (Multiple data communication command in Modbus protocol) can be used. 	<ul style="list-style-type: none"> Initial setup (*) of the PLC is required. Number of PLC data addresses changes depending on increase/decrease of the number of controllers.
Flagless method	Max. 95 units	<ul style="list-style-type: none"> The set values can be changed easily since the Set value change flag is not used. [Even when settings are changed on the PLC side (or controller side), those changes will automatically occur on the controller side (or PLC side)]. Data item and instrument number can be changed from the PLC side. 	<ul style="list-style-type: none"> Initial setup (*) of the PLC is required. A larger number of PLC register addresses are occupied as the PLC data, relevant instrument number and data item of the controller are set. As the data amount is increased, the response time becomes slower.
Fixed address method	Max. 20 units	<ul style="list-style-type: none"> PLC's initial setup (*) is easier to set. Number of PLC data addresses will not be changed even if the number of connected controllers are increased/decreased (Addresses for 20 units are constantly needed). 	<ul style="list-style-type: none"> As the PLC register is predetermined, a larger number of PLC register is occupied. Occupies 500-Words (20 units x 25 items).

(*) Console software (SWC-SIF01M) is used for settings.

Please download from Shinko website.

<http://shinko-technos.co.jp/e/> → Support & Downloads → Downloads → Software

2. Model

2.1 Model

SIF-600

2.2 How to Read the Model Label

Model label is attached to the left side of the case.

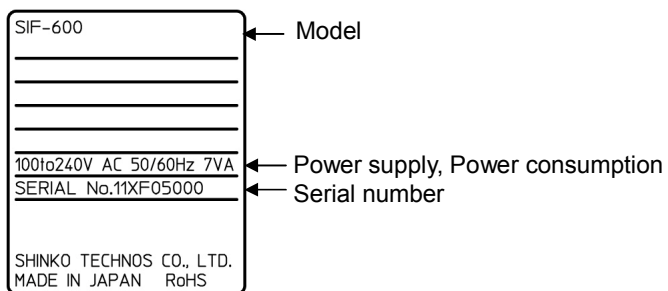

(Fig. 2.2-1)

3. Name and Functions of Sections

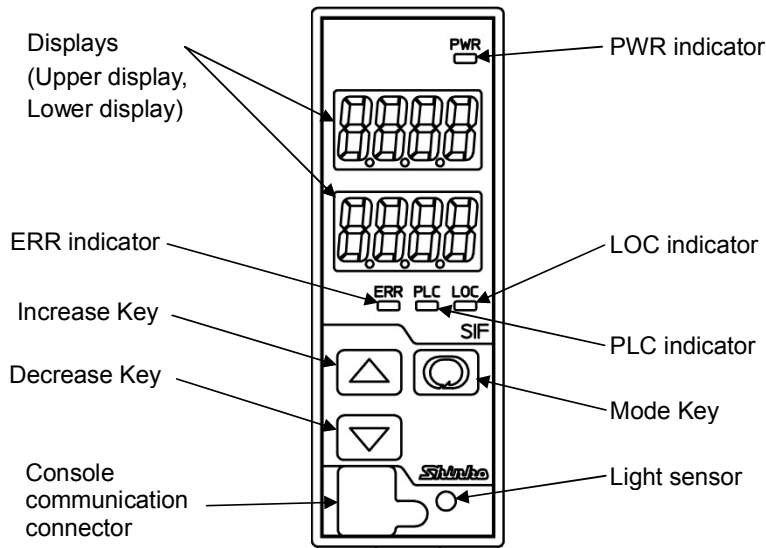

(Fig. 3-1)

Displays (Red)

Upper display:

- PLC model and communication status are indicated in Communication mode.
- Error characters flashes when communication errors occur.
- Setting characters are indicated in Parameter setting mode.

Lower display:

- PLC memory allocation methods are indicated in Communication mode.
- Error codes flashes when communication errors occur.
- The set values are indicated in Parameter setting mode.

Status Indicators

PWR indicator (yellow): Lit when the power is supplied to the instrument.

ERR indicator (red): Lit when communication errors have occurred.

PLC indicator (yellow): Lit while communicating with the PLC [Serial communication TX output (transmitting)].

LOC indicator (yellow): Lit while communicating with the controllers [Serial communication TX output (transmitting)].

Keys

Increase key (△): Increases the numeric value, or switches the selection item.

Decrease key (▽): Decreases the numeric value, or switches the selection item.

Mode key (⌚): Switches the Parameter setting mode, or registers the set value.

Console communication connector:

By connecting via the USB communication cable (CMB-001, sold separately), various setting data can be transmitted from an external computer via the Console software SWC-SIF01M (*).

(* Please download from Shinko website.

<http://shinko-technos.co.jp/e/> → Support & Downloads → Downloads → Software

Light sensor: Automatically measures and controls brightness of the displays.

4. Mounting, Removal

4.1 Site Selection



Caution

Use within the following temperature and humidity ranges.

Temperature: 0 to 50 °C (32 to 122 °F) (No icing), Humidity: 35 to 85 %RH (Non-condensing)

If SIF-600 is mounted within a control panel, the ambient temperature of the unit - not the ambient temperature of the control panel - must be kept to under 50 °C, otherwise the life of electronic parts (especially electrolytic capacitors) of the unit will be shortened.

This instrument is intended to be used under the following environmental conditions (IEC61010-1): Overvoltage category II, Pollution degree 2

Ensure the mounting location corresponds to the following conditions:

- A minimum of dust, and an absence of corrosive gases
- No flammable, explosive gases
- No mechanical vibrations or shocks
- No exposure to direct sunlight, an ambient temperature of 0 to 50 °C (32 to 122 °F) that does not change rapidly
- An ambient non-condensing humidity of 35 to 85 %RH
- No large capacity electromagnetic switches or cables through which large current is flowing
- No water, oil or chemicals or where the vapors of these substances can come into direct contact with the unit

4.2 External Dimensions (scale: mm)

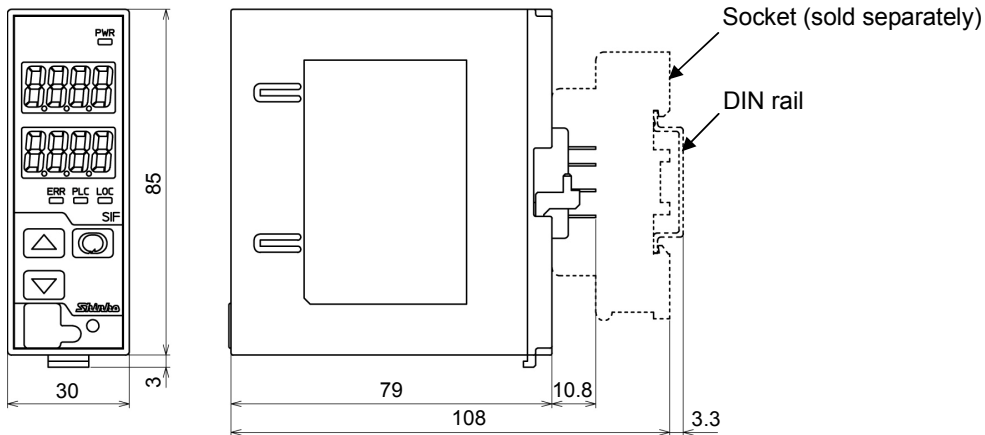

(Fig. 4.2-1)

4.3 Mounting

- (1) Hook the upper part of the socket on the DIN rail, and mount it (A clicking sound is heard).

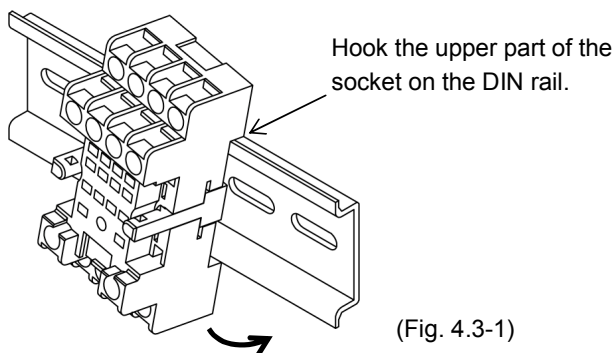

(Fig. 4.3-1)

⚠ Caution

Before inserting the SIF-600 into the socket, wire the unit while referring to Section “5. Wiring” (pp. 14 to 25).

(2) Check that the Lock Release has been lowered.

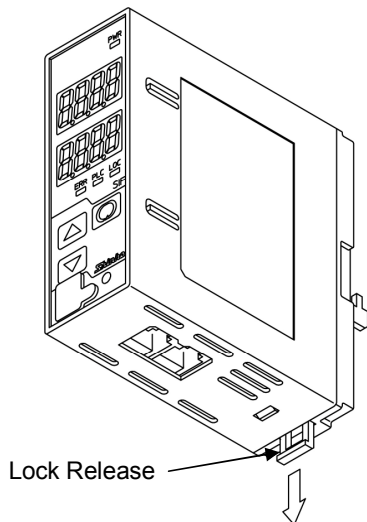

(Fig. 4.3-2)

(3) Insert the SIF-600 into the socket.

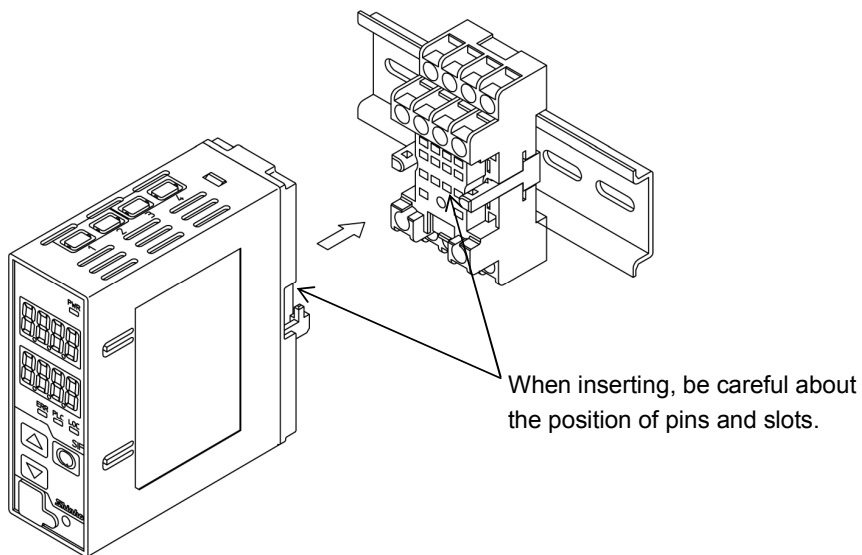

(Fig. 4.3-3)

(4) Fix the SIF-600 and the socket by pushing the Lock Release up.

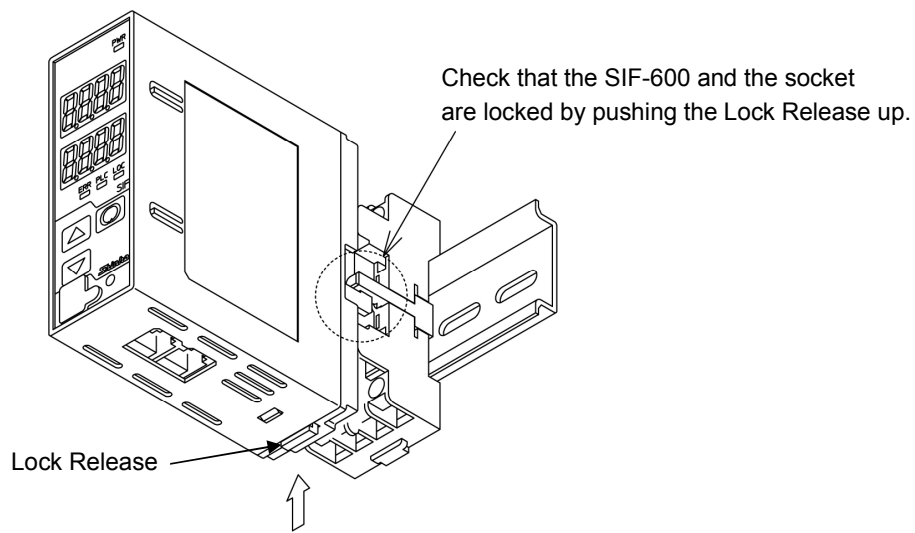

(Fig. 4.3-4)

4.4 Removal

(1) Turn the power supply to the unit OFF.

(2) Pull the Lock Release down, and release the SIF-600 from the socket.

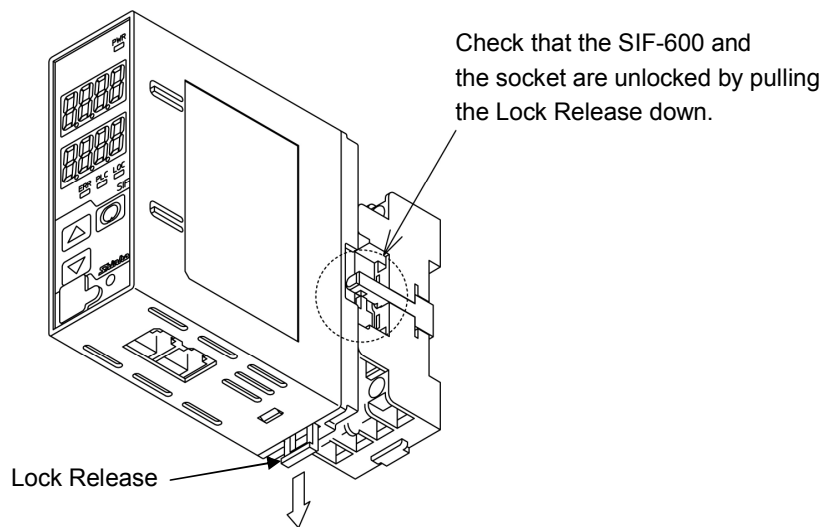

(Fig. 4.4-1)

(3) Separate the SIF-600 from the socket.

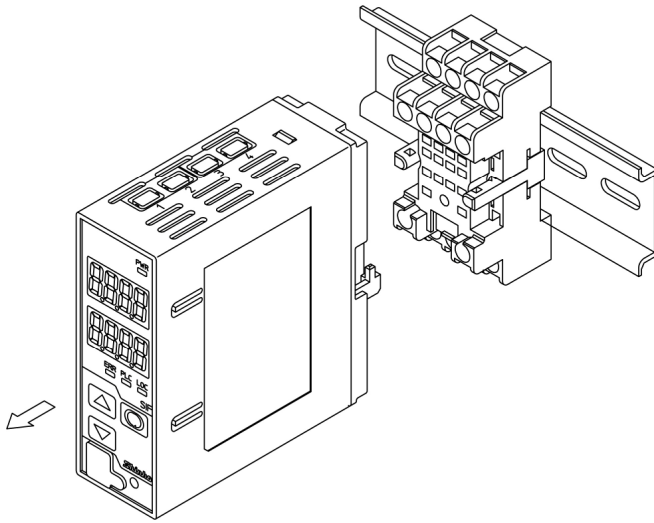

(Fig. 4.4-2)

(4) Remove the socket from the DIN rail by pulling the Socket Lock Release (at the bottom of the socket) down.

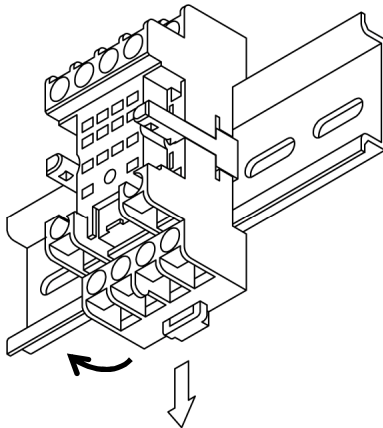

(Fig. 4.4-3)

5. Wiring

⚠ Warning

Turn the power supply to the instrument OFF before wiring or checking.
 Working on or touching the terminal with the power switched ON may result in severe injury or death due to electric shock.

⚠ Caution

- Do not leave wire remnants in the instrument, because they could cause a fire or a malfunction.
- Use a solderless terminal with an insulation sleeve in which the M3 screw fits when wiring the SIF-600.
- Tighten the terminal screw using the specified torque. If excessive force is applied to the screw when tightening, the terminal screw may be damaged.
- This instrument does not have a built-in power switch, circuit breaker or fuse.
 Be sure to install a built-in power switch, circuit breaker or fuse near the instrument.
 (Recommended fuse: Time-lag fuse, rated voltage 250 V AC, rated current 2 A)
- For a 24 V AC/DC power source, do not confuse polarity when using direct current (DC).

5.1 Lead Wire Solderless Terminal

Use a solderless terminal with an insulation sleeve in which an M3 screw fits as follows. (Table 5.1-1)
 For sockets with finger-safe & screw fall prevention functions, the ring terminals cannot be used.
 The tightening torque should be 0.63 N•m.

(Table 5.1-1)

Solderless Terminal	Manufacturer	Model
Y-type	Nichifu Terminal Industries CO., LTD.	TMEV1.25Y-3S
Ring-type	Nichifu Terminal Industries CO., LTD.	TMEV1.25-3
	Japan Solderless Terminal MFG CO., LTD.	V1.25-3

Y-type

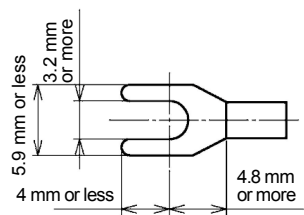

(Fig. 5.1-1)

Ring-type

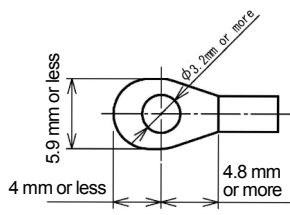

(Fig. 5.1-2)

5.2 Terminal Arrangement

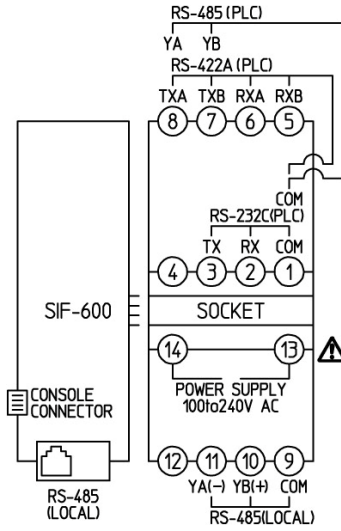

(Fig. 5.2-1)

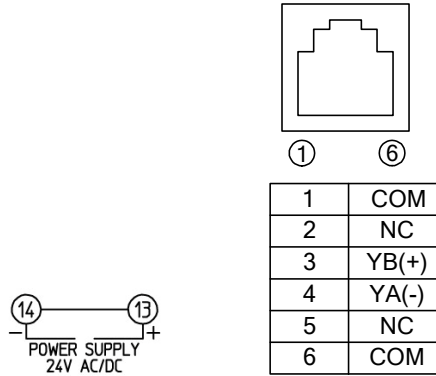

Modular jack pin arrangement (SIF-600 side)
RS-485 (LOCAL)

(Fig. 5.2-2)

RS-485(PLC), RS-422A(PLC), RS-232C(PLC): Terminals for communication with PLC
For RS-422A, a terminator (200 Ω) is built in between RXA and RXB.

POWER SUPPLY: Power terminals

RS-485(LOCAL): Terminals for communication with controllers, Modular jack.
Use in accordance with the connected controllers.

5.3 Connecting Power Terminals

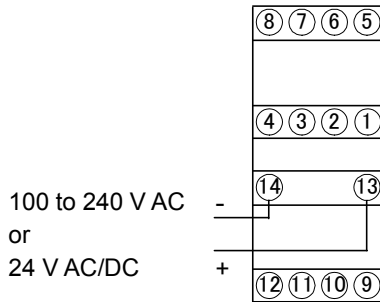

(Fig. 5.3-1)

5.4 Connecting to a PLC

5.4.1 Connecting to a Mitsubishi PLC

RS-422A:

Using the communication cable (*), connect the units.

Refer to (Fig. 5.4.1-1) below.

Calculator link unit (AJ71UC24, A1SJ71UC24-R4, A1SJ71C24-R4)

Micro PLC (FX series)

Serial communication module (QJ71C24)

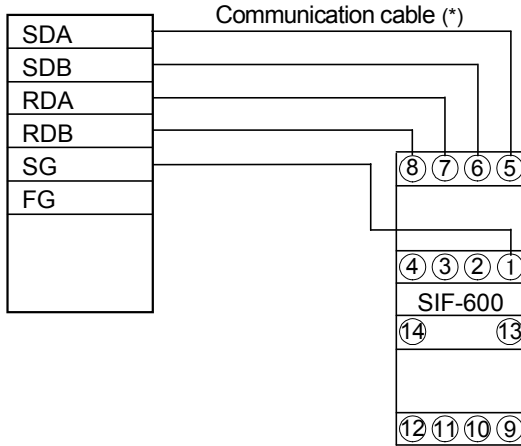

(Fig. 5.4.1-1)

RS-485:

Using the communication cable (*), connect the units.

Refer to (Fig. 5.4.1-2) below.

Calculator link unit (AJ71UC24, A1SJ71UC24-R4, A1SJ71C24-R4)

Micro PLC (FX series)

Serial communication module (QJ71C24)

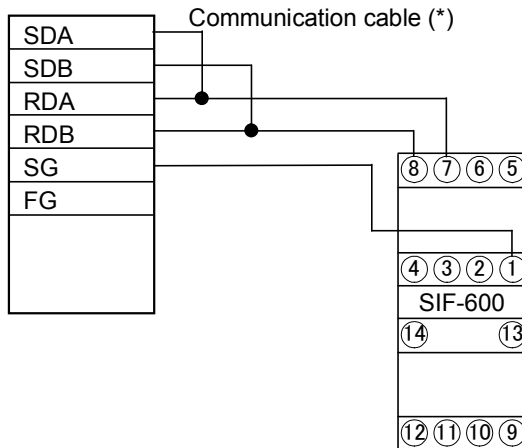

(Fig. 5.4.1-2)

RS-232C:

Using the communication cable (*), connect the units.
Refer to (Fig. 5.4.1-3) below.

Calculator link unit (AJ71UC24, A1SJ71UC24-R4, A1SJ71C24-R2/PRF)
Micro PLC (FX series)
Serial communication module (QJ71C24)

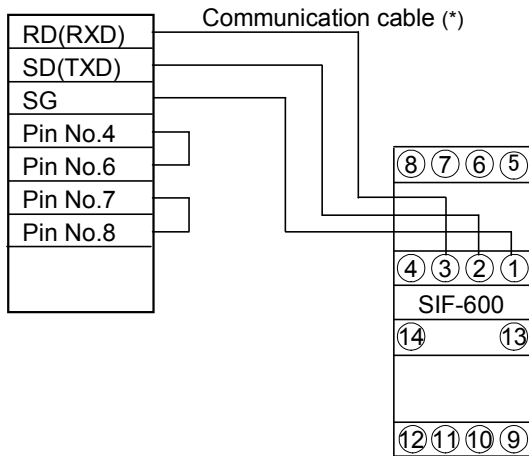

(Fig. 5.4.1-3)

(*) For the communication cable, please consult us or our agency.

5.4.2 Connecting to an Omron PLC

RS-422A:

Using the communication cable (*), connect the units.
Refer to (Fig. 5.4.2-1) below.

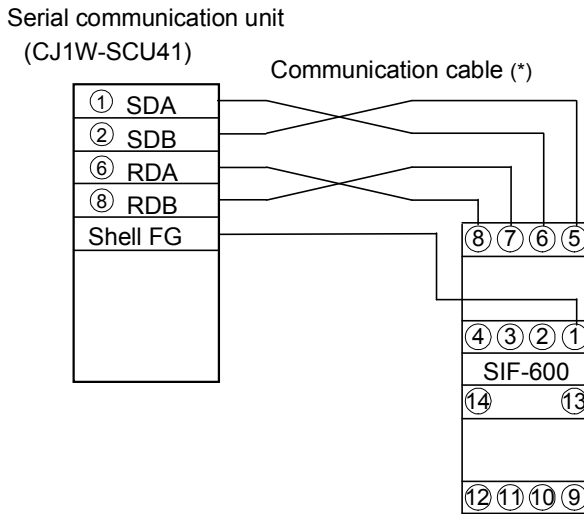

(Fig. 5.4.2-1)

RS-232C:

Using the communication cable (*), connect the units.
Refer to (Fig. 5.4.2-2) below.

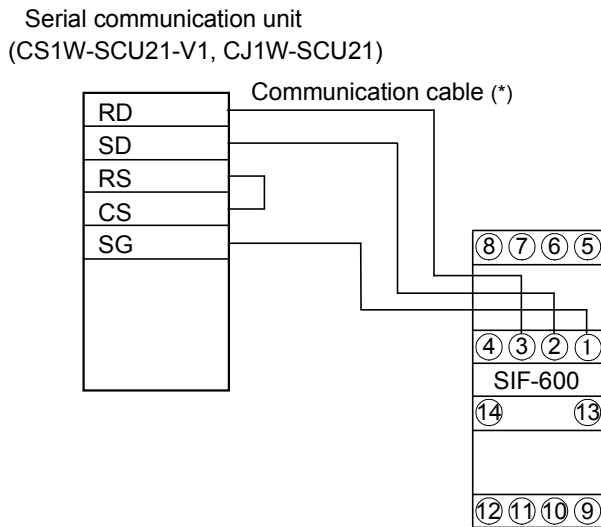

(Fig. 5.4.2-2)

(*) For the communication cable, please consult us or our agency.

5.4.3 Connecting to a Keyence PLC

RS-422A:

Using the communication cable (*), connect the units.
Refer to (Fig. 5.4.3-1) below.

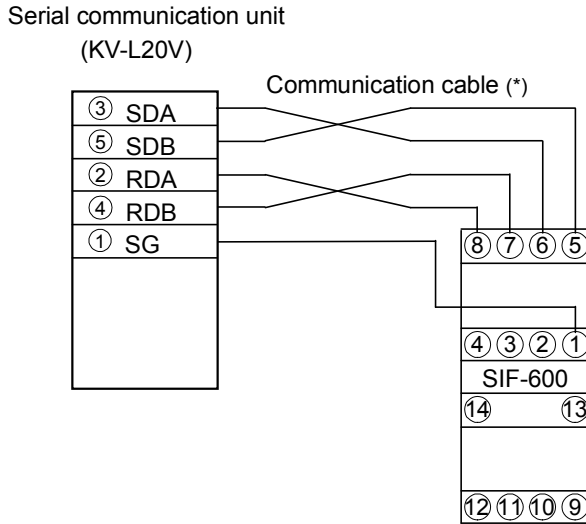

(Fig.5.4.3-1)

RS-232C:

Using the communication cable (*), connect the units.
Refer to (Fig. 5.4.3-2) below.

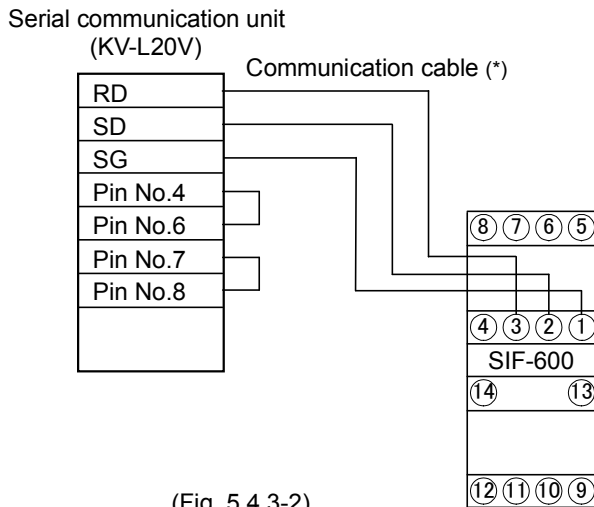

(Fig. 5.4.3-2)

(*) For the communication cable, please consult us or our agency.

5.4.4 Connecting to a Yokogawa PLC

RS-422A:

Using the communication cable (*), connect the units.
Refer to (Fig. 5.4.4-1) below.

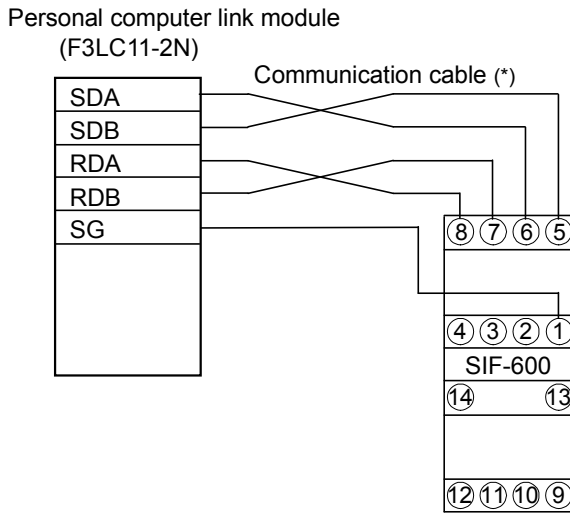

(Fig. 5.4.4-1)

RS-232C:

Using the communication cable (*), connect the units.
Refer to (Fig. 5.4.4-2) below.

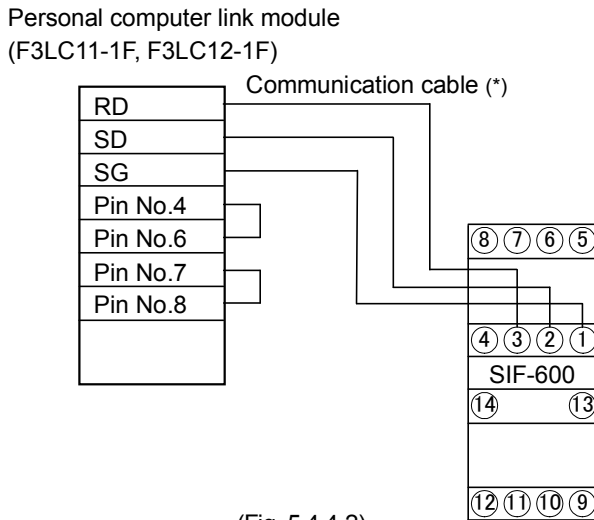

(Fig. 5.4.4-2)

(*) For the communication cable, please consult us or our agency.

5.4.5 Connecting to a Fuji PLC

RS-422A:

Using the communication cable (*), connect the units.
Refer to (Fig. 5.4.5-1) below.

General-purpose communication module
(NP1L-RS1, NP1L-RS4)

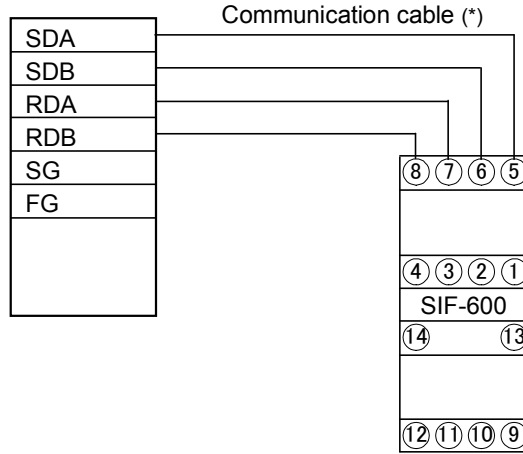

(Fig. 5.4.5-1)

RS-232C:

Using the communication cable (*), connect the units.
Refer to (Fig. 5.4.5-2) below.

General-purpose communication module
(NP1L-RS2, NP1L-RS3)

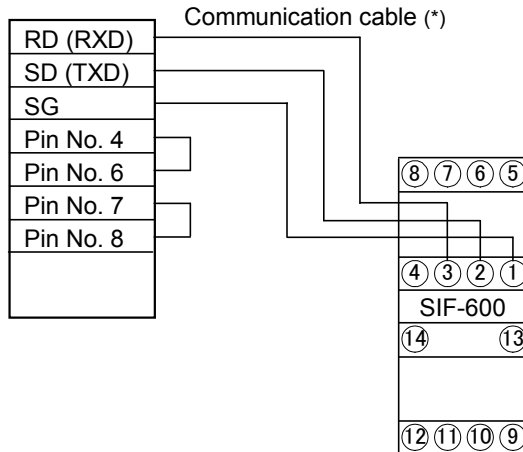

(Fig. 5.4.5-2)

(*) For the communication cable, please consult us or our agency.

5.5 Connecting to Digital Indicating Controllers

5.5.1 Connecting to the WCL-13A

Connection between the SIF-600 and WCL-13A

Using communication cable CDD (sold separately) or CPP (sold separately), connect modular jacks.

Length of CDD: 60 mm

For distances larger than 60 mm, use the CPP cable.

Length of CPP: 500 mm

For distances larger than 500 mm, the CPP can be extended in units of 500 mm fixed length.

For distances less than 500 mm, the CPP can be cut down in units of 100 mm fixed length.

Connection between the WCL-13A and WCL-13A

Using communication cable CDD (sold separately), connect modular jacks.

Repeaters are necessary when connecting 32 or more controllers.

Shinko communication converter IF-400 can be used as a repeater.

For the connection method, refer to the Instruction Manual for the IF-400.

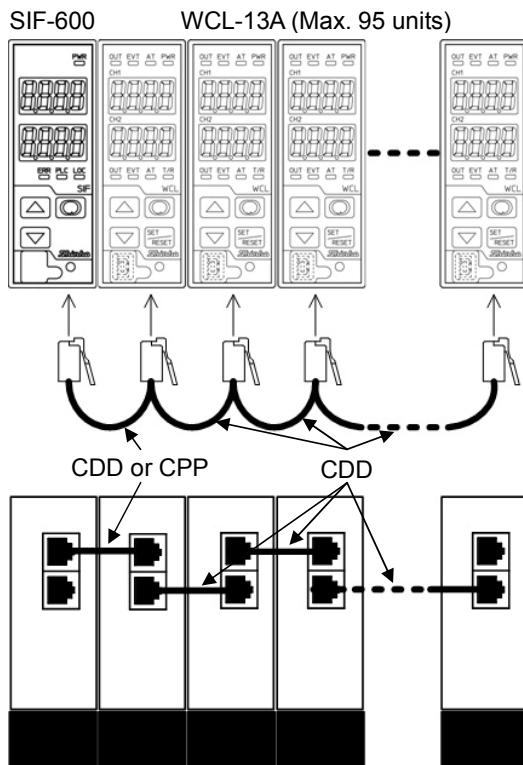

(Fig. 5.5.1-1)

5.5.2 Connecting to the DCL-33A

Connection between the SIF-600 and DCL-33A

Using communication cable CDD (sold separately) or CPP (sold separately), connect modular jacks.

Length of CDD: 60 mm

For distances larger than 60 mm, use the CPP cable.

Length of CPP: 500 mm

For distances larger than 500 mm, the CPP can be extended in units of 500 mm fixed length.

For distances less than 500 mm, the CPP can be cut down in units of 100 mm fixed length.

Connection between the DCL-33A and DCL-33A

Using communication cable CDD (sold separately), connect modular jacks.

Repeaters are necessary when connecting 32 or more controllers.

Shinko communication converter IF-400 can be used as a repeater.

For the connection method, refer to the Instruction Manual for the IF-400.

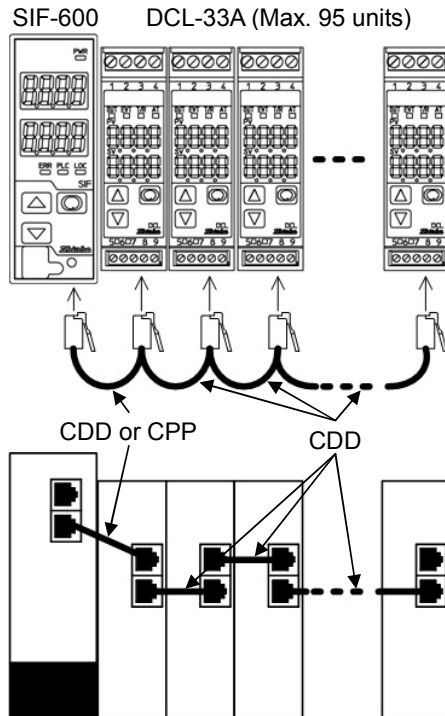

(Fig. 5.5.2-1)

5.5.3 Connecting to the NCL-13A

Connection between the SIF-600 and NCL-13A

Using communication cable CNS (sold separately), connect the CNS modular jack to the SIF-600, and connect the CNS terminals to C (COM), A (YA), B (YB) terminals of Screw Type Plug for Lines (Terminal block ATB-001-1) of NCL-13A.

Length of CNS: 500 mm

The CNS cable can be extended in units of 500 mm fixed length.

Connection between two or more NCL-13A units

Connect bus plugs in series.

Repeaters are necessary when connecting 32 or more controllers.

Shinko communication converter IF-400 can be used as a repeater.

For the connection method, refer to the Instruction Manual for the IF-400.

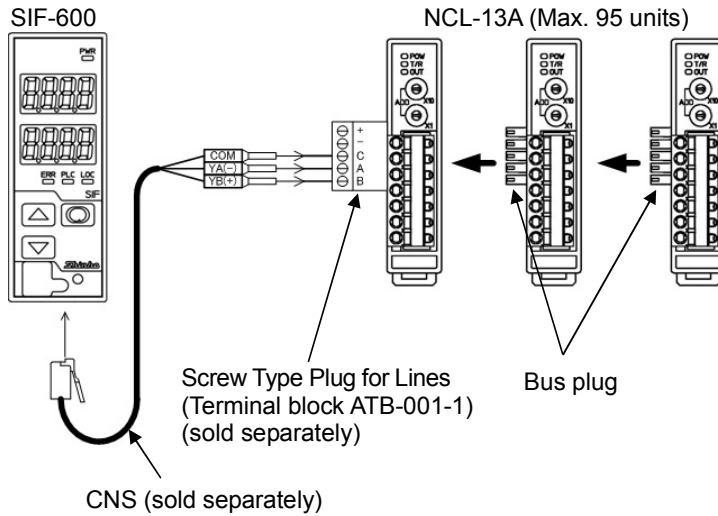

(Fig. 5.5.3-1)

5.5.4 Connecting to the ACx-13A, JCx-33A Series

Connection between the SIF-600 and ACx-13A/JCx-33A series

Using a communication cable CDM (sold separately), connect the CDM modular jack to the SIF-600, and connect the CDM terminals to YA(-), YB(+), SG terminals of the ACx-13A/JCx-33A series.

Length of CDM: 3000 mm

The cable can be extended in units of 1000 mm fixed length.

Connection between the ACx-13A/JCx-33A

Using a shielded wire, connect YA(-) to YA(-), YB(+) to YB(+), SG to SG terminal.

Connect only one end of the shielded wire to the FG terminal so that current cannot flow to the shielded wire.

If both ends of the shielded wire are connected to the FG terminal, the circuit will be closed between the shielded wire and the ground. As a result, current will run through the shielded wire and this may cause noise.

Be sure to ground FG terminal.

Recommended cable: OTSC-VB 2PX0.5SQ (made by Onamba Co., Ltd.) or equivalent (Use a twisted pair cable.)

The JCS-33A is used as an example in the following explanation.

ACx-13A, JCx-33A series have different terminal numbers depending on the model.

For connection, refer to (Table 5.5.4-1), (Table 5.5.4-2).

Repeaters are necessary when connecting 32 or more controllers.

Shinko communication converter IF-400 can be used as a repeater.

For the connection method, refer to the Instruction Manual for the IF-400.

(Table 5.5.4-1) ACx-13A Series

CDM	ACS-13A	ACR-13A	ACD-13A
4	⑬YA(-)	⑬YA(-)	⑬YA(-)
3	⑭YB(+)	⑭YB(+)	⑭YB(+)
1, 6	⑮SG	⑮SG	⑮SG

(Table 5.5.4-2) JCx-33A Series

CDM	JCL-33A	JCS-33A	JCR-33A	JCM-33A	JCD-33A
4	⑩YA(-)	⑬YA(-)	⑪YA(-)	⑩YA(-)	⑪YA(-)
3	⑪YB(+)	⑭YB(+)	⑭YB(+)	⑬YB(+)	⑭YB(+)
1, 6	⑫SG	⑮SG	⑰SG	⑭SG	⑰SG

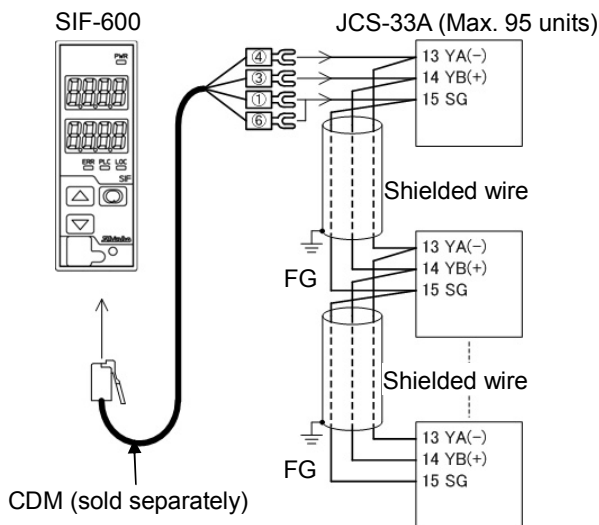

(Fig. 5.5.4-1)

6. Setup

Setup should be done before using this instrument, in order to select a PLC model, controller model, the PLC communication parameters, etc. according to the users' conditions.

(Table 6-1) shows the setup methods for the SIF-600 and PLC.

For the SIF-600, console software and keypad operation (Parameter setting mode) are used for the setup.

For the PLC, Switches or setting tools are used for setup.

If setup has already been complete, it is not necessary to set up the SIF-600. Proceed to Section "7. Operation (p.74)".

(Table 6-1)

Object unit	Setup method	Contents of setup
SIF-600	Console software (SWC-SIF01M) (*)	Sets PLC system address, PLC memory allocation method, Data address, RO/RW, data items, etc. See Section "6.2 Setup via Console Software". (pages 27 to 57)
	Key operation (Parameter setting mode)	Sets PLC model, controller model, PLC communication parameters, etc. See Section "6.3 Setup in Parameter Setting Mode". (pages 58 to 62).
PLC	Switches or setting tools, etc. (Setting method differs depending on the manufacturer or model.)	Sets communication parameters. See Section "6.4 Setup of the PLC". (pages 63 to 73)

(*) Please download from Shinko website.

<http://shinko-technos.co.jp/e/> → Support & Downloads → Downloads → Software

6.1 Shifting to Each Mode of the SIF-600

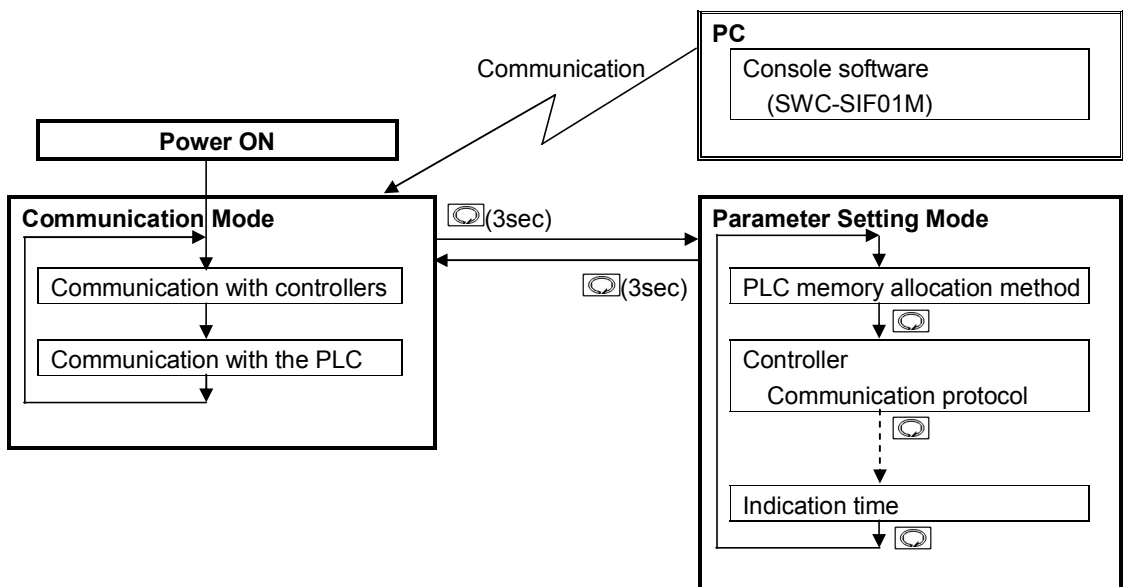

(Fig. 6.1-1)

6.1.1 Communication Mode

After the power to the SIF-600 is switched ON, the unit enters Communication mode. In Communication mode, the SIF-600 communicates with the controllers and the PLC under the conditions set by the console software and key operation (in Parameter setting mode). Data Read/Write is constantly performed.

6.1.2 Console Software

For the SIF-600 to communicate with the digital indicating controllers and the PLC, settings such as PLC system address, PLC memory allocation method, PLC data address, RO/RW, data items, etc. are carried out via the console software (SWC-SIF01M) (*). Data can be transmitted by connecting the USB communication cable CMB-001 (sold separately).



(*) Please download from Shinko website.

<http://shinko-technos.co.jp/e/> → Support & Downloads → Downloads → Software

6.1.3 Parameter Setting Mode

If the  key is pressed for approx. 3 seconds in Communication mode, the unit moves to Parameter setting mode.

In Parameter setting mode, PLC model, digital indicating controllers and PLC communication parameters, etc. are set for the SIF-600 to communicate with the digital indicating controllers and the PLC.

Use  or  key for settings, and register the value with the  key.

If the  key is pressed and held down for approx. 3 seconds, the unit will revert to Communication mode.

6.2 Setup via Console Software

For the SIF-600 to communicate with the digital indicating controllers and the PLC, settings such as PLC system address, PLC memory allocation method, PLC data address, RO/RW, data items, etc. are carried out via the Console software (SWC-SIF01M).

Data can be transmitted by connecting the USB communication cable CMB-001 (sold separately).

System configuration is shown below (Fig. 6.2-1).

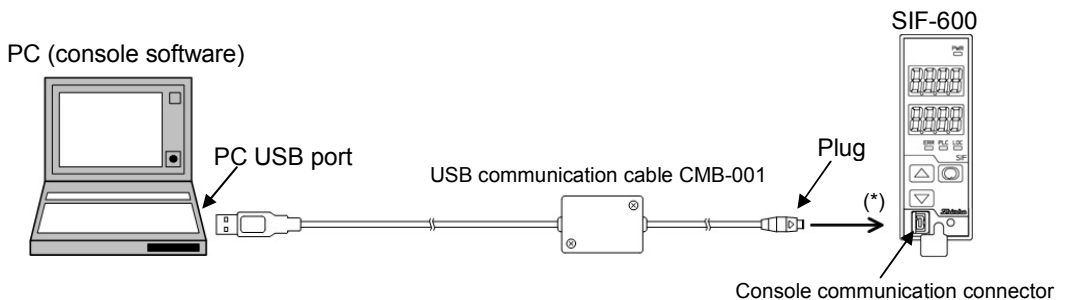

(*) Ensure plugs are inserted securely.

(Fig. 6.2-1)

PLC memory allocation methods are shown in (Table 6.2-1) below.

(Table 6.2-1)

PLC memory allocation method	Contents
Flexible address method	Constantly updates RO (Read Only) data items. Manages RW (Read/Write) data item settings via the Set value change flag. See Section “6.2.1 Setup Using the Flexible Address Method” (pages 30 to 36).
Multi address method	Block communication command (Multiple data communication command in Modbus protocol) can be used. (*) Constantly updates RO (Read Only) data items. Manages RW (Read/Write) data items via the Set value change flag. See Section “6.2.2 Setup Using the Multi Address Method” (pages 37 to 43).
Flagless method	Constantly updates RO (Read Only) data items. Manages RW (Read/Write) data items without using the Set value change flag. See Section “6.2.3 Setup Using the Flagless Method” (pages 44 to 50).
Fixed address method	20 units are fixed in the PLC register. Constantly updates RO (Read Only) data items. Manages RW (Read/Write) data items via the Set value change flag. See Section “6.2.4 Setup Using the Fixed Address Method” (pages 51 to 57).

(*) This method can be used for Shinko Multi-point temperature control system C series or Temperature control boards.

Factory default: Fixed address method

PLC register section is shown in (Table 6.2-2) and (Table 6.2-3).

(Table 6.2-2) System Section

PLC address	Contents
500	PLC communication status, Controller communication status
501	Update counter
502	Set value change flag

(Table 6.2-3) Data Section

Data items correspond to the WCL-13A (Digital indicating controller).

Data No.	PLC address	RO/RW	Data item		Data amount	Set value change flag number (*2)
1	1000 to 1019	RW	0001	SV	20	Read: -2/Write: 2
2	1020 to 1039	RW	0051	SV (CH2)	20	Read: -3/Write: 3
3	1040 to 1059	RW	000B	Alarm 1 value (CH1)	20	Read: -4/Write: 4
4	1060 to 1079	RW	005B	Alarm 1 value (CH2)	20	Read: -5/Write: 5
5	1080 to 1099	RW	0003	OUT1 proportional band (CH1)	20	Read: -6/Write: 6
6	1100 to 1119	RW	0053	OUT1 proportional band (CH2)	20	Read: -7/Write: 7
7	1120 to 1139	RW	0005	Integral time (CH1)	20	Read: -8/Write: 8
8	1140 to 1159	RW	0055	Integral time (CH2)	20	Read: -9/Write: 9
9	1160 to 1179	RW	0006	Derivative time (CH1)	20	Read: -10/Write: 10
10	1180 to 1199	RW	0056	Derivative time (CH2)	20	Read: -11/Write: 11
11	1200 to 1219	RW	0007	ARW (CH1)	20	Read: -12/Write: 12
12	1220 to 1239	RW	0057	ARW (CH2)	20	Read: -13/Write: 13
13	1240 to 1259	RW	0002	AT/ Auto-reset Perform/Cancel (CH1)	20	Read: -14/Write: 14
14	1260 to 1279	RW	0052	AT/ Auto-reset Perform/Cancel (CH2)	20	Read: -15/Write: 15
15	1280 to 1299	RW	0028	Control Allowed/Prohibited (CH1)	20	Read: -16/Write: 16
16	1300 to 1319	RW	0078	Control Allowed/Prohibited (CH2)	20	Read: -17/Write: 17
17	1320 to 1339	RW	0015	Sensor correction (CH1)	20	Read: -18/Write: 18
18	1340 to 1359	RW	0065	Sensor correction (CH2)	20	Read: -19/Write: 19
19	1360 to 1379	RO (*1)	0080	PV reading (CH1)	20	Read: -20/Write: 20
20	1380 to 1399	RO (*1)	0090	PV reading (CH2)	20	Read: -21/Write: 21
21	1400 to 1419	RO (*1)	0081	Output MV reading (CH1)	20	Read: -22/Write: 22
22	1420 to 1439	RO (*1)	0091	Output MV reading (CH2)	20	Read: -23/Write: 23
23	1440 to 1459	RO (*1)	0083	Status flag reading (CH1)	20	Read: -24/Write: 24
24	1460 to 1479	RO (*1)	0093	Status flag reading (CH2)	20	Read: -25/Write: 25
25	1480 to 1499		0000	Reserved	20	Read: -20/Write: 20

(*1) RO specified Data No. is Read Only item and the Set value change flag is disabled.

(*2) About Set value change flag number:

The Set value change flag in the Fixed address method is predetermined. It cannot be changed.

When “-1” is written to the Set value change flag, the SIF-600 reads all data items (set in the PLC register section) from the controller, and writes them to the PLC register section.

“Read” (Set value change flag number is negative) means that the SIF-600 reads data from the digital indicating controllers and writes it to the PLC register section.

“Write” (Set value change flag number is positive) means that the SIF-600 reads data from the PLC register section, and sends the setting command to the digital indicating controller.

If the user's specification is the same as the factory default value of the unit, or if setup has already been complete, it is not necessary to set up the SIF-600. Proceed to Section “6.3 Setup in Parameter Setting Mode” (pages 58 to 62).

From the next page, setup method will be explained using respective PLC memory allocation methods.

6.2.1 Setup Using the Flexible Address Method

In the Flexible address method, RO (Read Only) data items are constantly updated.
For RW (Read/Write) data items, their settings are managed by the Set value change flag.

Data exchange occurs as follows.

RO (Read Only) data items: The SIF-600 constantly reads them from the controller, and writes them to the PLC register.

RW (Read/Write) data items: If the Set value change flag is set, the SIF-600 will send the setting/reading command to the corresponding controller (of relevant data item and instrument number).

(1) Setup Items

Setup items on the console software are shown in (Table 6.2.1-1).

(Table 6.2.1-1)

Setting item	Attribute	Contents	Setting example
System reference address	PLC register	PLC top address allocated in the system section	200 (*1)
Data reference address	PLC register	PLC top address allocated in the Data section	500 (*1)
RO/RW No.1 to 500	RO/RW command	Sets RO/RW command to each Data No. RO: Read Only data (PV, status, etc.) RW: Read/Write data (SV, alarm value, etc.)	No.1: RW No.2: RW No.3: RW No.4: RO (*2) No.5: RO (*2) No.6: RO (*2)
Instrument number, Sub address No.1 to 500	High-order: Instrument number Low-order: Sub address	Sets the instrument number and sub address of the controller to each Data No. (*3)	No.1: 0000H No.2: 0100H No.3: 0200H No.4: 0000H No.5: 0100H No.6: 0200H
Data item No.1 to 500	Reference	Sets communication reference number (1 to 500) of setting items to each Data No. (*4)	No.1: 0001H No.2: 0001H No.3: 0001H No.4: 0080H No.5: 0080H No.6: 0080H
Flag No. No.1 to 500	Set value change flag	Sets the Set value change flag number to each Data No. If the number set here is set to the Set value change flag, setting processes will be performed. (*5)	No.1: 2 No.2: 2 No.3: 2 No.4: 0 No.5: 0 No.6: 0

(*1) 3-Words are occupied in system section.

When setting the top data address, be careful not to duplicate the system addresses.

(*2) For RO/RW command, set RW first, then RO in that order only.

(*3) Setting range of Instrument numbers differs depending on the communication protocol selection.

- When Shinko protocol is selected: Set instrument numbers (0 to 95) randomly, avoiding duplication.
- When Modbus protocol is selected: Set instrument numbers (1 to 95) randomly, avoiding duplication.

(*4) Notes when setting Data items

If Modbus protocol is selected in [Communication protocol selection], the SIF-600 will send the value (40001 of offset is subtracted from the reference number of Data item) to the digital indicating controller via communication commands.

When setting Data items, take note of the following:

- If 'Shinko controllers' is selected in [Select controller]:

The Console software sets the value (40001 of offset is automatically added to the reference number of Data item) on the SIF-600.

Setting range of reference number of Data item is 0000H to FFFFH, however, set the number within the range of 0000(0) to 63BEH [25534 (65535 - 40001)] so that the value (to which 40001 of offset is added) cannot exceed FFFFH (65535).

(e.g.) For Data item 0001H: Write 1

For Data item 0080H: Write 128.

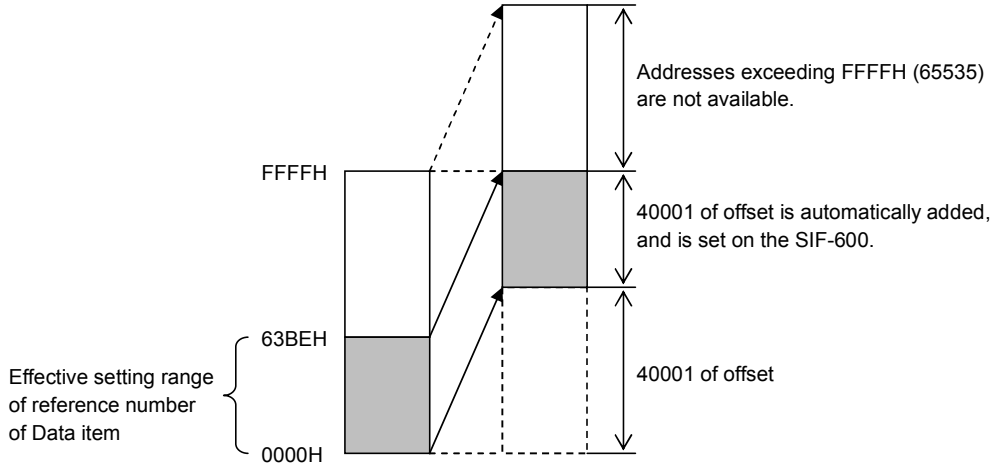

(Fig. 6.2.1-1)

- If 'Other' is selected in [Select controller]:

The Console software sets the value on the SIF-600 without adding 40001 of offset to the reference number of Data item.

Set the value to which 40001 of offset is added.

Setting range of reference number of Data item is 0000H to FFFFH, however, set the number within the range of 9C41 [40001 (0+40001)] to FFFFH [65535 (25534+40001)] so that the value (to which 40001 of offset is added) cannot exceed FFFFH (65535).

(e.g.) For Data item 0001H: Write 40002 (1+40001).

For Data item 0080H: Write 40129 (128+40001).

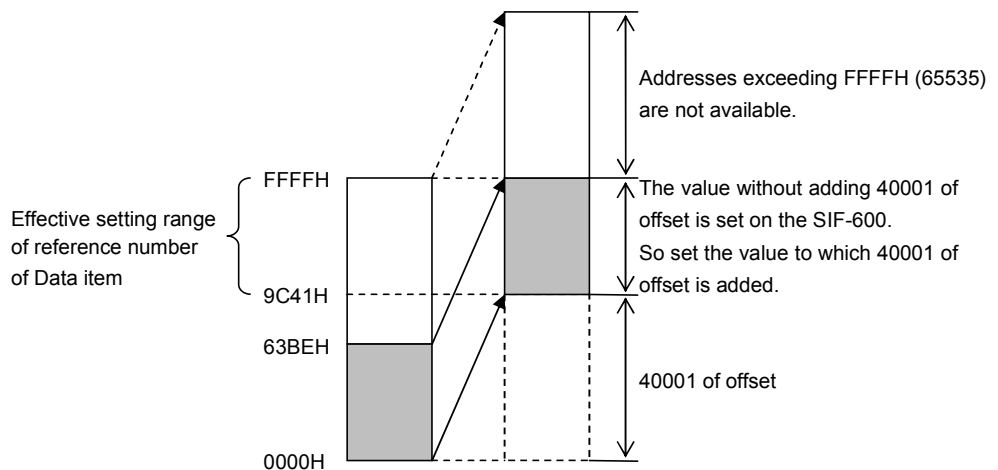

(Fig. 6.2.1-2)

(*5) For the Flexible address method, the function of Set value change flag number 1 is predetermined.

If "1" is written to the Set value change flag number, the SIF-600 will read all data items (set in the PLC register section) from the controller, and write them to the PLC register section.

Set the flag number from 2 to 255 randomly.

(2) PLC System Section

The following items in (Table 6.2.1-2) are allocated in the PLC system section.

(Table 6.2.1-2)

Item	Address	Functions
PLC communication status, Controller communication status	System reference address	PLC communication status (impossible to detect in case of no response): B0: Sum error B7: Other Controller communication status: B8: Negative acknowledgement B9: Checksum error B10: No response B15: Other
Update counter	System reference address +1	Counter is updated every time communication occurs. 0 to 65535 (Returns to 0 when 65535 is exceeded.) This is used to determine communication errors with the PLC.
Set value change flag	System reference address +2	Set value change flag section. If Set value change flag is set to any other value except 0 (zero), corresponding data item settings will be processed. After setting processes are complete, the SIF-600 returns the Set value change flag to "0".

(3) PLC Register Section

If setup is carried out using "(1) Setup Items" as an example, the PLC register will be described in (Table 6.2.1-3) and (Table 6.2.1-4).

(Table 6.2.1-3) System Section

PLC address	Contents
200	PLC communication status, Controller communication status
201	Update counter
202	Set value change flag

(Table 6.2.1-4) Data Section

Data No.	PLC address	RO/RW	High-order: Instrument number Low-order: Sub address	Data item	Flag number
1	500	RW	00H/00H	0001H	2
2	501	RW	01H/00H	0001H	2
3	502	RW	02H/00H	0001H	2
4	505 (*)	RO	00H/00H	0080H	0
5	506 (*)	RO	01H/00H	0080H	0
6	507 (*)	RO	02H/00H	0080H	0

(*) As a PLC address, any addresses except the consecutive addresses from the top address can be set randomly.

Using “(1) Setup Items (p.30)” as an example, setup procedures on the console software will be described.

① **Starting the console software**

From the start menu, select [All Programs] – [SHINKO TECHNOS] – [SWC-SIF01M], and click. The SIF-600 Console Software will start, and Step 1 Startup parameters selection display will appear.

② **Step 1 Startup parameters selection**

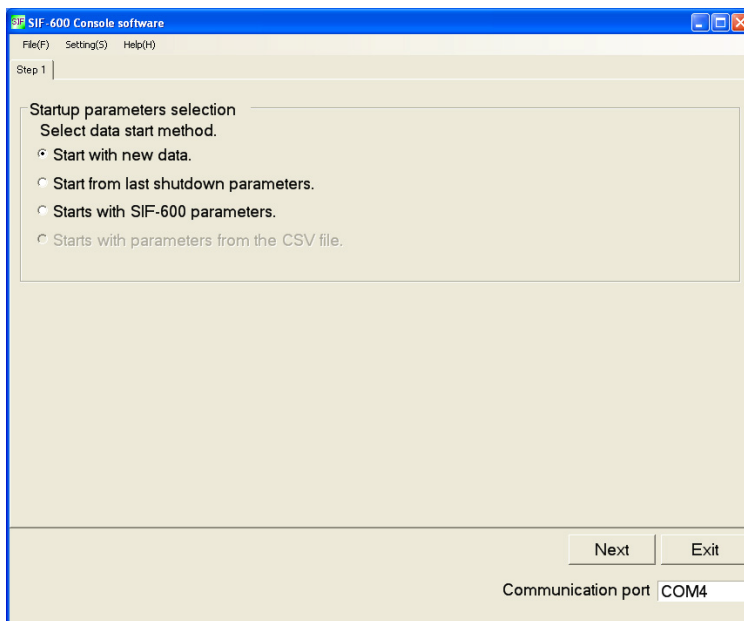

(Fig. 6.2.1-3)

Select a data start method, and click [Next]. Step 2 PLC memory allocation method display will appear.

③ **Step 2 PLC memory allocation method**

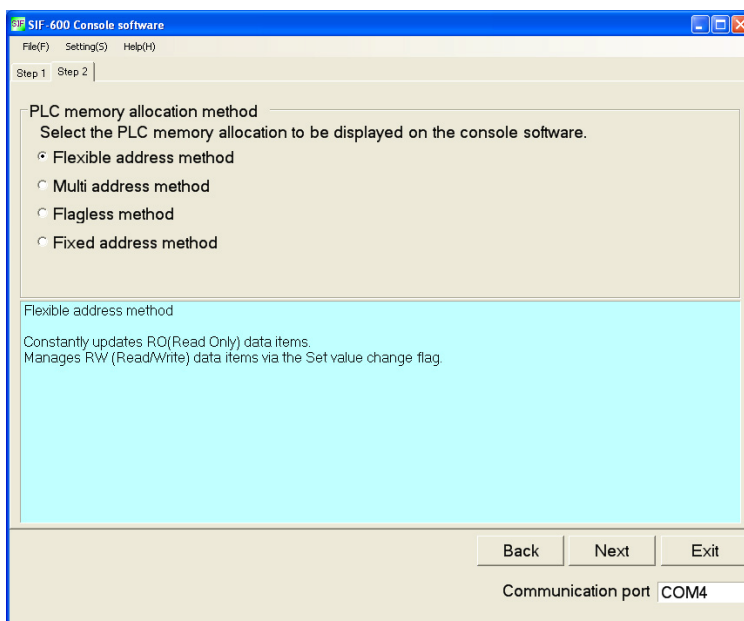

(Fig. 6.2.1-4)

Item	Setting
PLC memory allocation method	Flexible address method

Select a PLC memory allocation method, and click [Next].

Step 3 System data setting display will appear.

④ Step 3 System data setting

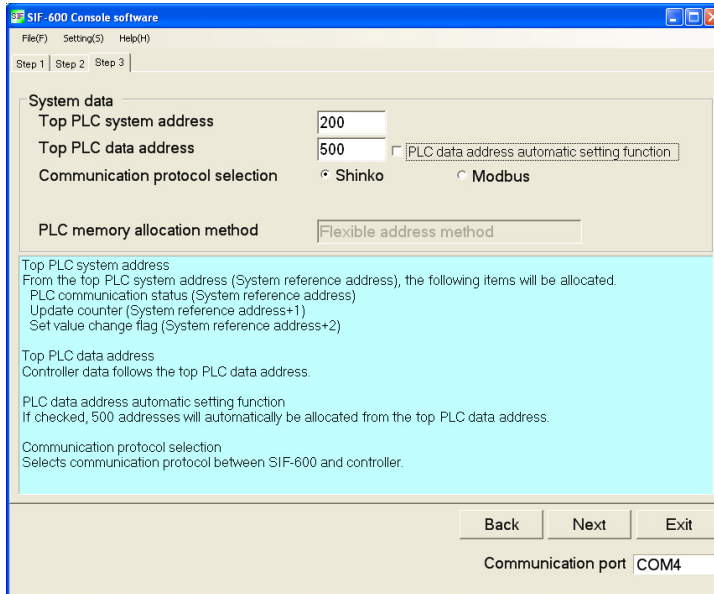

(Fig. 6.2.1-5)

- Top PLC system address (In the system addresses, communication status of the PLC and controller, update counter, etc. are allocated.)
- Top PLC data address (In the data addresses, RO/RW, data item, etc. are allocated.)

Item	Setting
Top PLC system address	200 (*)
Top PLC data address	500 (*)

(*) 3-Words are occupied in system section.

When setting the top PLC data address, be careful not to duplicate the PLC system addresses.

Set the top PLC system address and top PLC data address, click [Next].

Step 4 PLC data setting display will appear.

⑤ Step 4 PLC data setting

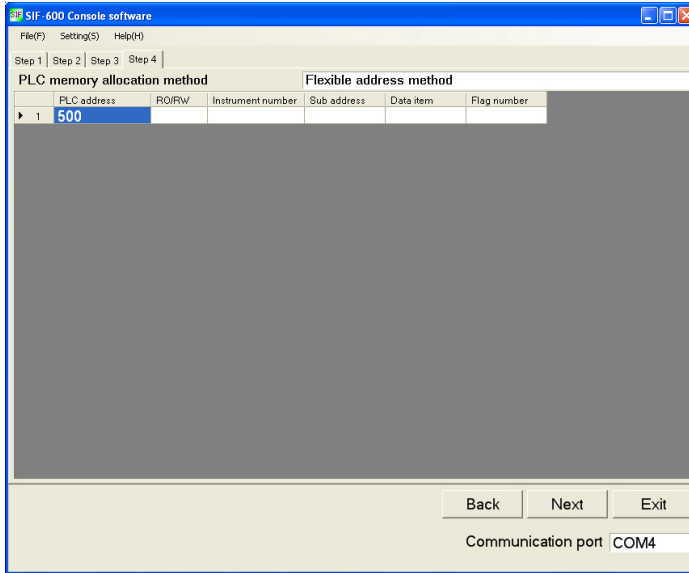

(Fig. 6.2.1-6)

PLC data section can be set.

Place the cursor at Data No.1, right-click and choose [Edit data] from the menu.

No.1 parameter setting display will be opened.

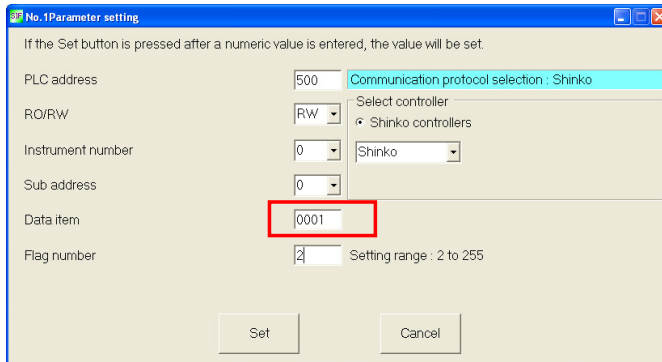

(Fig. 6.2.1-7)

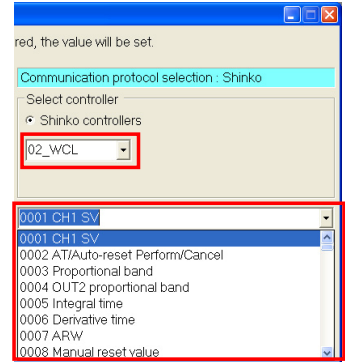

(Fig. 6.2.1-8)

Set the following.

Item	Setting
PLC address	500
RO/RW	RW
Instrument number	0
Sub address	0
Data item (*)	0001
Flag number	2

(*) There are 2 methods in data item setting.

1. Direct input (Fig. 6.2.1-7)

Set the reference number using decimal number(s).

Console software will set the reference number (converted to hexadecimal number) on the SIF-600.

2. Select from the data item list. (Fig. 6.2.1-8)

If a controller model is selected in [Select controller], the pull-down box will appear on the right side of the data item.

If the button on right end is clicked, data item list will appear.

Select from the list.

Right-click and select [Add data] from the menu, then set other PLC data section in the same way.

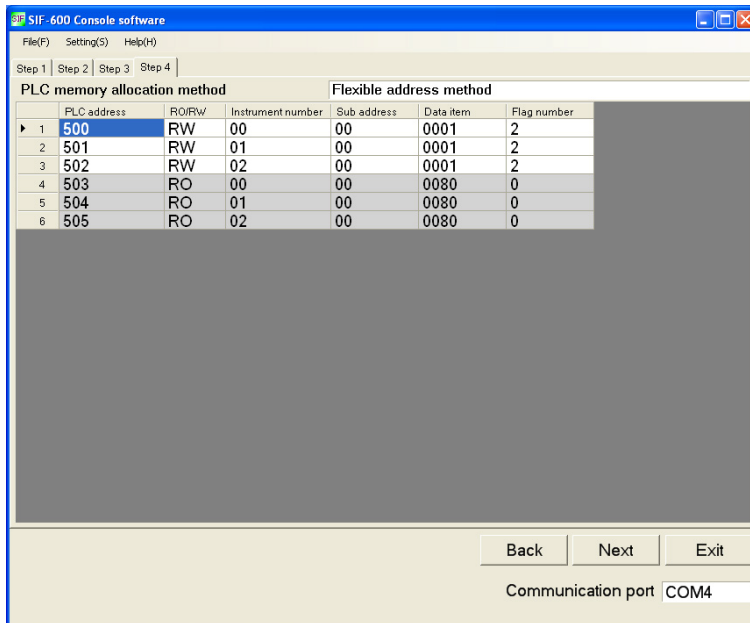

(Fig. 6.2.1-9)

Click [Next].

Step 5 data transmission display will appear.

⑥ Step 5 Data transmission

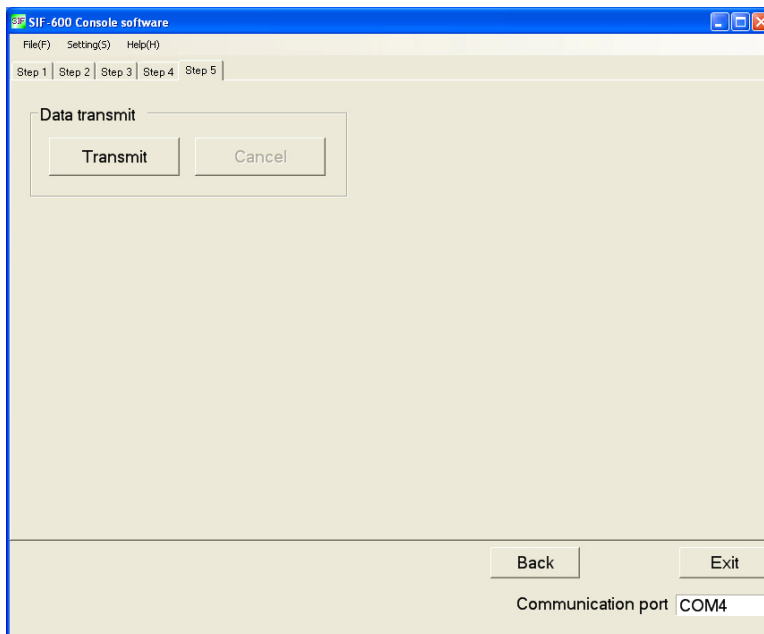

(Fig. 6.2.1-10)

Connect the USB communication cable CMB-001 (sold separately), and transmit the data.

Setup is now complete.

6.2.2 Setup Using the Multi Address Method

Block communication command (multiple data communication command in Modbus protocol) (*) can be used for Multi address method.

This method can be used for Shinko Multi-point temperature control system C series or Temperature control boards.

RO (Read Only) data items are constantly updated.

For RW (Read/Write) data items, their settings are managed by the Set value change flag.

(*) Amount of multiple data (communication command) differs depending on the communication protocol.

- Shinko protocol: Max. 20
- Modbus protocol: Max. 50

Data exchange occurs as follows.

RO (Read Only) data items: The SIF-600 constantly reads from the digital indicating controllers, and writes amount of data to the PLC register.

RW (Read/Write) data items: If the Set value change flag is set, the SIF-600 sends the setting/reading command to the corresponding controller (of relevant data item and instrument number).

(1) Setup Items

Setup items on the console software are described in (Table 6.2.2-1).

(Table 6.2.2-1)

Setting item	Attribute	Contents	Setting example
System reference address	PLC register	Top PLC address allocated as the system section	200 (*1)
PLC address No.1 to 500	PLC register	Allocates PLC register addresses for each Data No.	No. 1 : 1000 (*1) (*2) No. 4 : 1003 (*2) No. 7 : 2000 (*2) No.10 : 2003 (*2)
RO/RW No.1 to 500	RO/RW command	Sets RO/RW command for each Data No. RO: Read Only data (PV, status, etc.) RW: Read/Write data (SV, alarm value, etc.)	No. 1 : RW (*2) No. 4 : RW (*2) No. 7 : RO (*2) (*3) No.10 : RO (*2) (*3)
Instrument number, Sub address No.1 to 500	High-order: Instrument number Low-order: Sub address	Sets an instrument number and sub address of the controller to each Data No. (*4)	No. 1 : 0000H (*2) No. 4 : 0100H (*2) No. 7 : 0000H (*2) No.10 : 0100H (*2)
Data item No.1 to 500	Reference	Sets communication reference number (1 to 500) of setting items for each Data No. (*5)	No. 1 : 0001H (*2) No. 4 : 0001H (*2) No. 7 : 0080H (*2) No.10 : 0080H (*2)
Flag No. No.1 to 500	Set value change flag	Sets the Set value change flag number to each Data No. If the number here is set to the Set value change flag, setting process will be performed. (*6)	No. 1 : 2 (*2) No. 4 : 2 (*2) No. 7 : 0 (*2) No.10 : 0 (*2)
PLC data amount No.1 to 500	Number of PLC registers	Sets the number of PLC registers to each Data No. The set data amount is allocated in the data section consecutively. Block communication command (multiple data communication command in Modbus protocol) can be used. (*7)	No. 1 : 3 (*2) No. 4 : 3 (*2) No. 7 : 3 (*2) No.10 : 3 (*2)

(*1) 3-Words are occupied in the system section.

When setting the top data address, be careful not to duplicate the system addresses.

(*2) For the other Data No. (No.2, 3, 8, 9, etc.) not listed in (Table 6.2.2-1), settings are not necessary as they have been automatically occupied by the PLC data amount setting.

(*3) For RO/RW command, set RW first, then RO in that order only.

(*4) Setting range of instrument numbers differs depending on the communication protocol selection.

- When Shinko protocol is selected: Set instrument numbers (0 to 95) randomly, avoiding duplication.
- When Modbus protocol is selected: Set instrument numbers (1 to 95) randomly, avoiding duplication.

(*5) Notes when setting Data items

If Modbus protocol is selected in [Communication protocol selection], the SIF-600 will send the value (40001 of offset is subtracted from the reference number of data item) to the digital indicating controller via communication commands.

When setting Data items, take note of the following:

- If 'Shinko controllers' is selected in [Select controller]:

The Console software sets the value (40001 of offset is automatically added to the reference number of Data item) on the SIF-600.

Setting range of reference number of Data item is 0000H to FFFFH, however, set the number within the range of 0000(0) to 63BEH [25534 (65535 - 40001)] so that the value (to which 40001 of offset is added) cannot exceed FFFFH (65535).

(e.g.) For Data item 0001H: Write 1

For Data item 0080H: Write 128.

- If 'Other' is selected in [Select controller]:

The Console software sets the value on the SIF-600 without adding 40001 of offset to the reference number of Data item.

Set the value to which 40001 of offset is added.

Setting range of reference number of Data item is 0000H to FFFFH, however, set the number within the range of 9C41 [40001 (0+40001)] to FFFFH [65535 (25534+40001)] so that the value (to which 40001 of offset is added) cannot exceed FFFFH (65535).

(e.g.) For Data item 0001H: Write 40002 (1+40001).

For Data item 0080H: Write 40129 (128+40001).

(*6) For the Multi address method, the function of Set value change flag number 1 is predetermined.

If "1" is written to the Set value change flag number, the SIF-600 will read all data items (set in the PLC register section) from the controller, and write them to the PLC register section.

Set the flag number from 2 to 255 randomly.

(*7) Amount of multiple data (communication command) differs depending on the communication protocol.

- Shinko protocol: Max. 20
- Modbus protocol: Max. 50

If C series (Shinko Multi-point temperature control system) is used, set the number of data to 20, regardless of the number of connected controllers of CCT-235-2□/□ (2ch temperature control unit).

(Data No. will be No.1, 21, 41, 61 as they are occupied by the number of PLC data.)

If TCB-235-10S/M (Shinko 10ch temperature control board) is used, set the number of data to 10.

(Data No. will be No.1, 11, 21, 31 as they are occupied by the number of PLC data.)

(2) PLC System Section

Items in (Table 6.2.2-2) are allocated in the PLC system section.

(Table 6.2.2-2)

Item	Address	Function
PLC communication status, Controller communication status	System reference address	PLC communication status (Impossible to detect in case of no response): B0: Sum error B7: Other Controller communication status: B8: Negative acknowledgement B9: Checksum error B10: No response B15: Other
Update counter	System reference address +1	Counter is updated every time communication occurs. 0 to 65535 (Returns to 0 when 65535 is exceeded.) This is used to determine communication errors with the PLC.
Set value change flag	System reference address +2	Set value change flag section. If Set value change flag is set to any other value except 0 (zero), corresponding data item settings will be processed. After setting process is complete, the SIF-600 returns the Set value change flag to 0 (zero).

(3) PLC Register Section

If setup is carried out using “(1) Setup Items” as an example, the PLC register will be described in (Table 6.2.2-3), (Table 6.2.2-4).

(Table 6.2.2-3) System Section

PLC address	Contents
200	PLC communication status, Controller communication status
201	Update counter
202	Set value change flag

(Table 6.2.2-4) Data Section

Data No.	PLC address	RO/RW	High-order: Instrument number Low-order: Sub address	Data item	Flag number	PLC data amount
1	1000	RW	00H/00H	0001H	2	3
2						
3						
4	1003	RW	01H/00H	0001H	2	3
5						
6						
7	2000	RO	00H/00H	0080H	0	3
8						
9						
10	2003	RO	01H/00H	0080H	0	3
11						
12						

Using “(1) Setup Items (p.37)” as an example, setup procedures on the console software will be described.

① **Starting console software**

From the start menu, select [All Programs] – [SHINKO TECHNOS] – [SWC-SIF01M], and click. The SIF-600 console software will start, and Step 1 Startup parameters selection display will appear.

② **Step 1 Startup parameters selection**

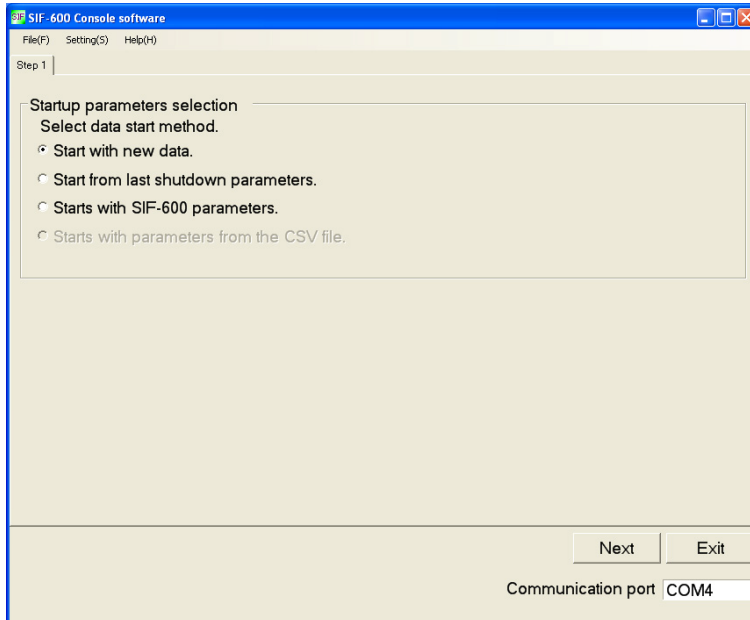

(Fig. 6.2.2-1)

Select a data start method, and click [Next]. Step 2 PLC memory allocation method display will appear.

③ **Step 2 PLC memory allocation method**

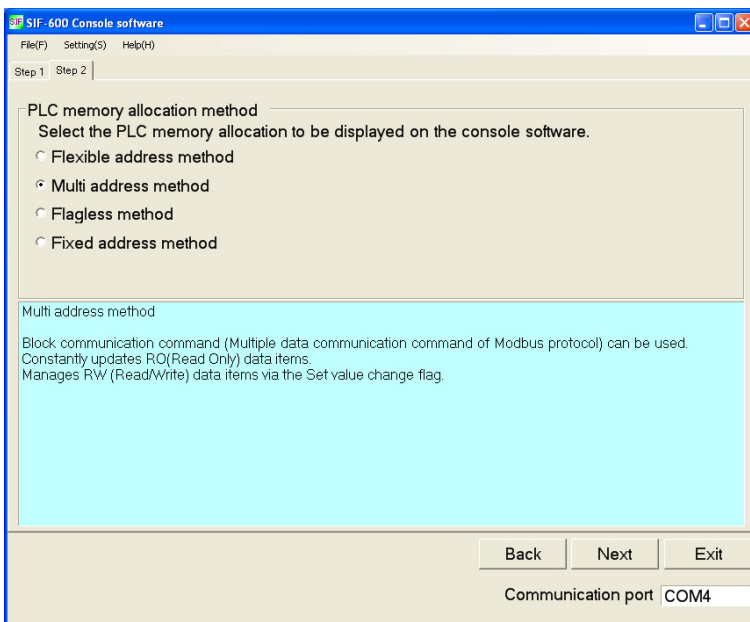

(Fig. 6.2.2-2)

Item	Setting
PLC memory allocation method	Multi address method

Select a PLC memory allocation method, and click [Next].
Step 3 System data setting display will appear.

④ Step 3 System data setting

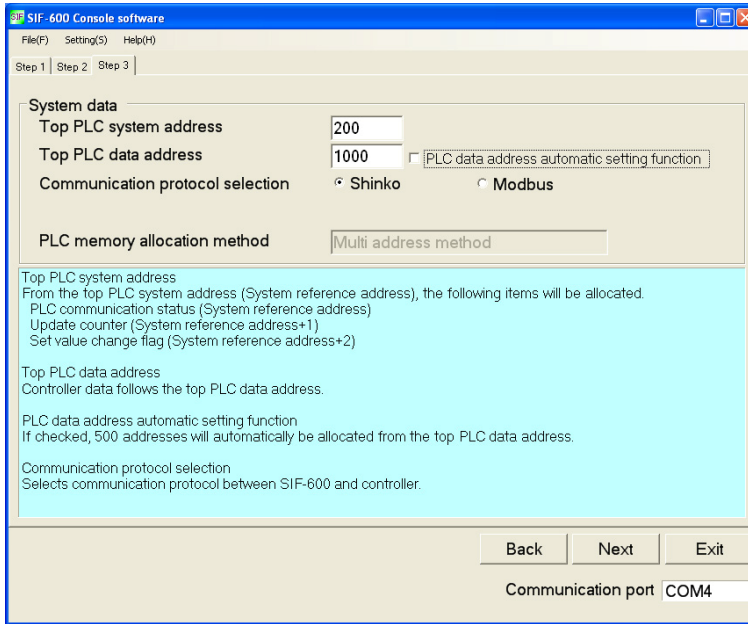

(Fig. 6.2.2-3)

- Top PLC system address (In the system addresses, communication status of the PLC and controller, update counter, etc. are allocated.)
- Top PLC data address (In the data addresses, RO/RW, data item, etc. are allocated.)

Item	Setting
Top PLC system address	200 (*)
Top PLC data address	1000 (*)

(*) 3-Words are occupied in system section.

When setting the top PLC data address, be careful not to duplicate the PLC system addresses.

Set the top PLC system address and top PLC data address, and click [Next].
Step 4 PLC data setting display will appear.

⑤ Step 4 PLC data setting

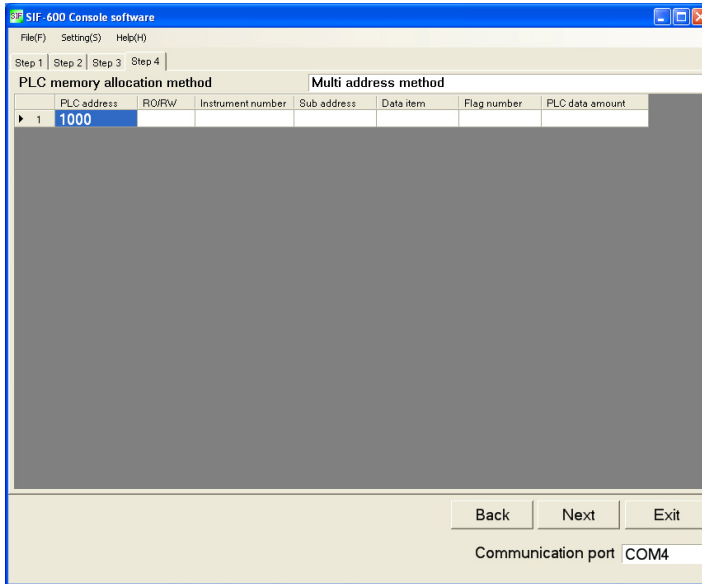

(Fig. 6.2.2-4)

PLC data section can be set.

Place the cursor at Data No.1, right-click and select [Edit data] from the menu.
No.1 parameter setting display will be opened.

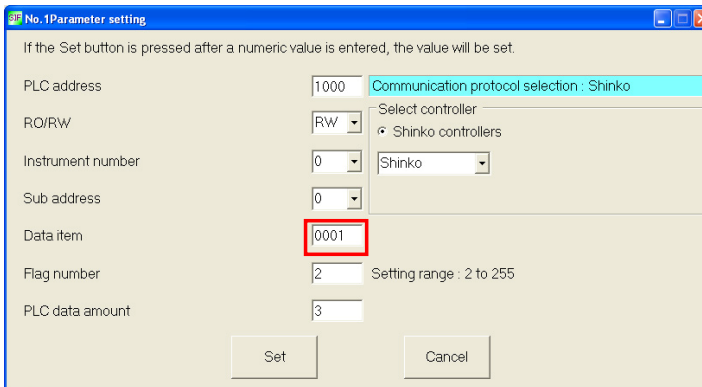

(Fig. 6.2.2-5)

Set the following.

Item	Setting
PLC address	1000
RO/RW	RW
Instrument number	0
Sub address	0
Data item (*)	1
Flag number	2
PLC data amount	3

(*) For Data item, set the reference number using decimal number(s).

Console software will set the reference number (converted to hexadecimal number) on the SIF-600.

Right-click and select [Add data] from the menu, then set other PLC data section in the same way.

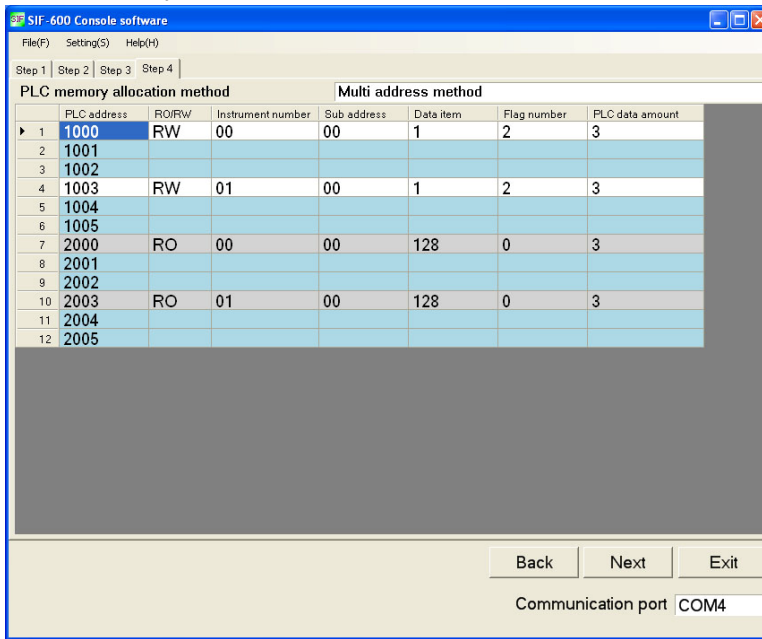

(Fig. 6.2.2-6)

Click [Next].

Step 5 Data transmission display will appear.

⑥ Step 5 Data transmission

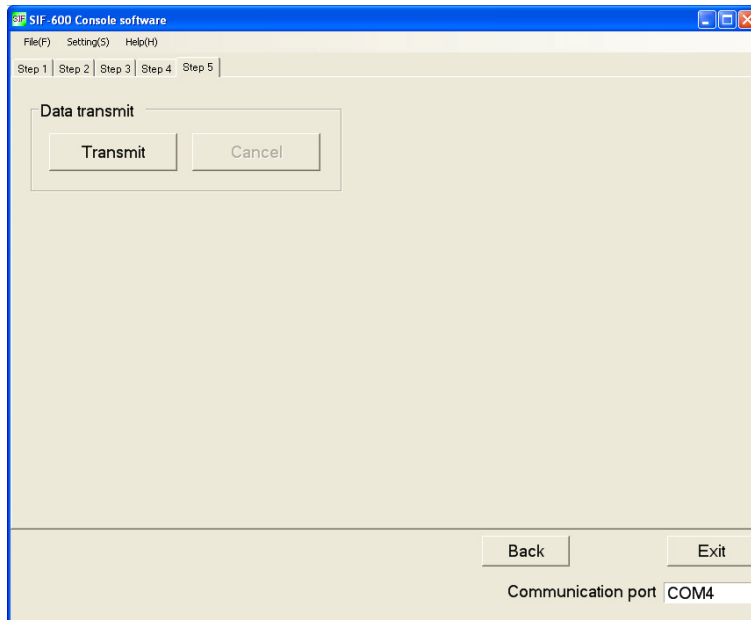

(Fig. 6.2.2-7)

Connect the USB communication cable CMB-001 (sold separately), and transmit the data.

Setup is now complete.

6.2.3 Setup Using the Flagless Method

With the Flagless method, RO (Read Only) data items are constantly updated.
RW (Read/Write) data item settings are managed without using the Set value change flag.

Data exchange occurs as follows.

The Set value change flag is not used for this method.

RO (Read Only) data items: The SIF-600 constantly reads from the digital indicating controllers, and writes to the PLC register.

RW (Read/Write) data items: The SIF-600 reads controller data and relevant PLC register data alternately, and if there is any change in data (in either PLC or controller), the opposite side data (in either controller or PLC) will be changed.

(1) Setup Items

Setup items on the console software are described in (Table 6.2.3-1).

(Table 6.2.3-1)

Setting item	Attribute	Contents	Setting example
System reference address	PLC register	Top PLC address allocated as the system section	200 (*1)
PLC address No.1 to 500	PLC register	Allocates PLC register addresses for each Data No.	No.1 : 1000 (*1) No.2 : 1001 No.3 : 1002 No.4 : 1003 No.5 : 1004 No.6 : 1005
RO/RW No.1 to 500	RO/RW command	Sets RO/RW command to each Data No. RO : Read Only data (PV, status, etc.) RW : Read/Write data (SV, alarm value, etc.)	No.1 : RW No.2 : RW No.3 : RW No.4 : RO (*2) No.5 : RO (*2) No.6 : RO (*2)
PLC address for saving controller's instrument number No.1 to 500	PLC register	Allocates instrument number addresses and sub address for every Data No.	No.1 : 1500 No.2 : 1501 No.3 : 1502 No.4 : 1503 No.5 : 1504 No.6 : 1505
PLC address for saving controller's data item No.1 to 500	PLC register	Allocates data item addresses (communication reference number of corresponding controller's setting item) for every Data No.	No.1 : 2000 No.2 : 2001 No.3 : 2002 No.4 : 2003 No.5 : 2004 No.6 : 2005

(*1) 3-Words are occupied in system section.

When setting the top data address, be careful not to duplicate the system addresses.

(*2) For RO/RW command, set RW first, then RO in that order only.

(2) PLC System Section

The following items in (Table 6.2.3-2) are allocated in the PLC system section.

(Table 6.2.3-2)

Item	Address	Function
PLC communication status, Controller communication status	System reference address	PLC communication status (Impossible to detect in case of no response): B0: Sum error B7: Other Controller communication status: B8: Negative acknowledgement B9: Checksum error B10: No response B15: Other
Update counter	System reference address +1	Counter is updated every time communication occurs. 0 to 65535 (Returns to 0 when 65535 is exceeded.) This is used to determine communication errors with the PLC.
Communication item change flag	System reference address +2	Communication item change flag section. Communication item change flag is set to "1" when controller's instrument number or data item has been changed. After the change process is complete, the SIF-600 returns the flag to 0 (zero).

(3) PLC Register Section

If setup is carried out using "(1) Setup Items" as an example, the PLC register section will be described in (Table 6.2.3-3) and (Table 6.2.3-4).

(Table 6.2.3-3) System Section

PLC address	Contents
200	PLC communication status, Controller communication status
201	Update counter
202	Communication item change flag

(Table 6.2.3-4) Data Section

Data No.	PLC address	RO/RW	PLC address for saving controller's instrument number	PLC address for saving controller's data item
1	1000	RW	1500	2000
2	1001	RW	1501	2001
3	1002	RW	1502	2002
4	1003	RO	1503	2003
5	1004	RO	1504	2004
6	1005	RO	1505	2005

For the PLC address for saving controller's instrument number and PLC address for saving controller's data item, write them via the PLC ladder software.

See the writing example in (Table 6.2.3-5).

(Table 6.2.3-5) Data Section PLC Register Details

PLC address	Data	Contents
1500	0000H	Data No.1 instrument number and sub address (*1) High-order: Instrument number, Low-order: Sub address
1501	0100H	Data No.2 instrument number and sub address (*1) High-order: Instrument number, Low-order: Sub address
1502	0200H	Data No.3 instrument number and sub address (*1) High-order: Instrument number, Low-order: Sub address
1503	0000H	Data No.4 instrument number and sub address (*1) High-order: Instrument number, Low-order: Sub address
1504	0100H	Data No.5 instrument number and sub address (*1) High-order: Instrument number, Low-order: Sub address
1505	0200H	Data No.6 instrument number and sub address (*1) High-order: Instrument number, Low-order: Sub address
2000	0001H	Data No.1 data item (*2)
2001	0001H	Data No.2 data item (*2)
2002	0001H	Data No.3 data item (*2)
2003	0080H	Data No.4 data item (*2)
2004	0080H	Data No.5 data item (*2)
2005	0080H	Data No.6 data item (*2)

(*1) Setting range of instrument numbers differs depending on the communication protocol selection.

- When Shinko protocol is selected: Set instrument numbers (0 to 95) randomly, avoiding duplication.
- When Modbus protocol is selected: Set instrument numbers (1 to 95) randomly, avoiding duplication.

(*2) Notes when setting Data items

If Modbus protocol is selected in [Communication protocol selection], the SIF-600 will send the value (40001 of offset is subtracted from the reference number of Data item) to the digital indicating controller via communication commands.

When setting Data items, take note of the following:

- If 'Shinko controllers' is selected in [Select controller]:
The Console software sets the value (40001 of offset is automatically added to the reference number of Data item) on the SIF-600.
Setting range of reference number of Data item is 0000H to FFFFH, however, set the number within the range of 0000(0) to 63BEH [25534 (65535 - 40001)] so that the value (to which 40001 of offset is added) cannot exceed FFFFH (65535). See (Fig. 6.2.1-1) on p. 31.
(e.g.) For Data item 0001H: Write 1
For Data item 0080H: Write 128.
- If 'Other' is selected in [Select controller]:
The Console software sets the value on the SIF-600 without adding 40001 of offset to the reference number of Data item.
Set the value to which 40001 of offset is added.
Setting range of reference number of Data item is 0000H to FFFFH, however, set the number within the range of 9C41 [40001 (0+40001)] to FFFFH [65535 (25534+40001)] so that the value (to which 40001 of offset is added) cannot exceed FFFFH (65535). See (Fig. 6.2.1-2) on p. 31.
(e.g.) For Data item 0001H: Write 40002 (1+40001).
For Data item 0080H: Write 40129 (128+40001).

Using “(1) Setup Items (p.44)” as an example, setup procedures on the console software will be described.

① **Starting console software**

From the start menu, select [All Programs] - [SHINKO TECHNOS] - [SWC-SIF01M], and click. The SIF-600 console software will start, and Step 1 Startup parameters selection display will appear.

② **Step 1 Startup parameters selection**

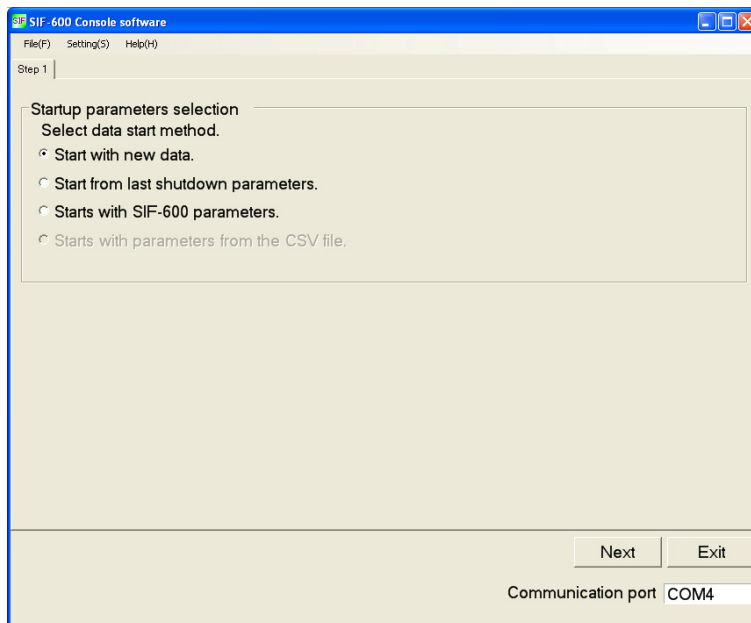

(Fig. 6.2.3-1)

Select a data start method, and click [Next].

Step 2 PLC memory allocation method display will appear.

③ **Step 2 PLC memory allocation method**

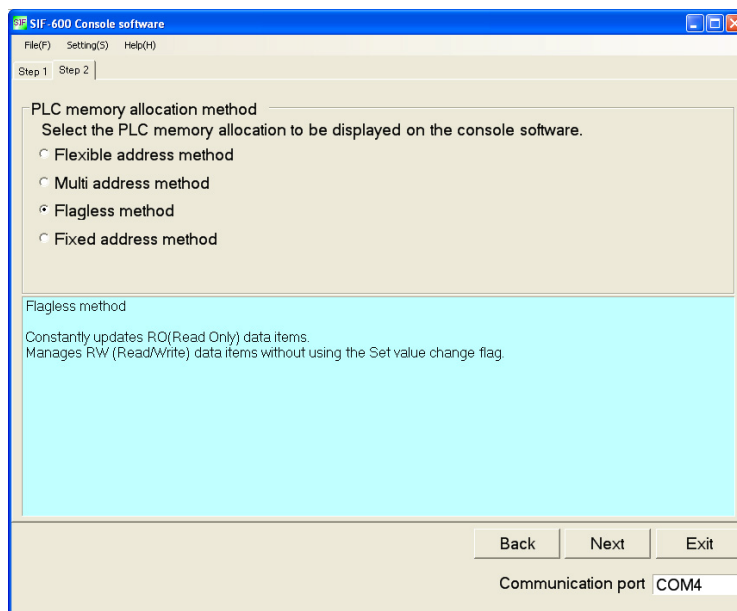

(Fig. 6.2.3-2)

Item	Setting
PLC memory allocation method	Flagless method

Select a PLC memory allocation method, and click [Next].
Step 3 System data setting display will appear.

④ Step 3 System data setting

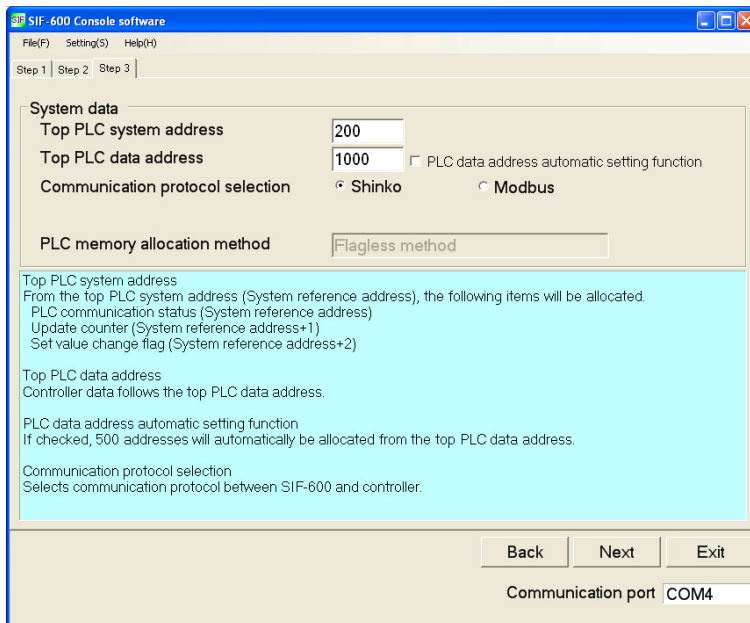

(Fig. 6.2.3-3)

- Top PLC system address (In the system addresses, communication status of the PLC and controller, update counter, etc. are allocated.)
- Top PLC data address (In the data addresses, RO/RW, data item, etc. are allocated.)

Item	Setting
Top PLC system address	200 (*)
Top PLC data address	1000 (*)

(*) 3-Words are occupied in system section.

When setting the top PLC data address, be careful not to duplicate the PLC system addresses.

Set the top PLC system address and top PLC data address, click [Next].
Step 4 PLC data setting display will appear.

⑤ Step 4 PLC data setting

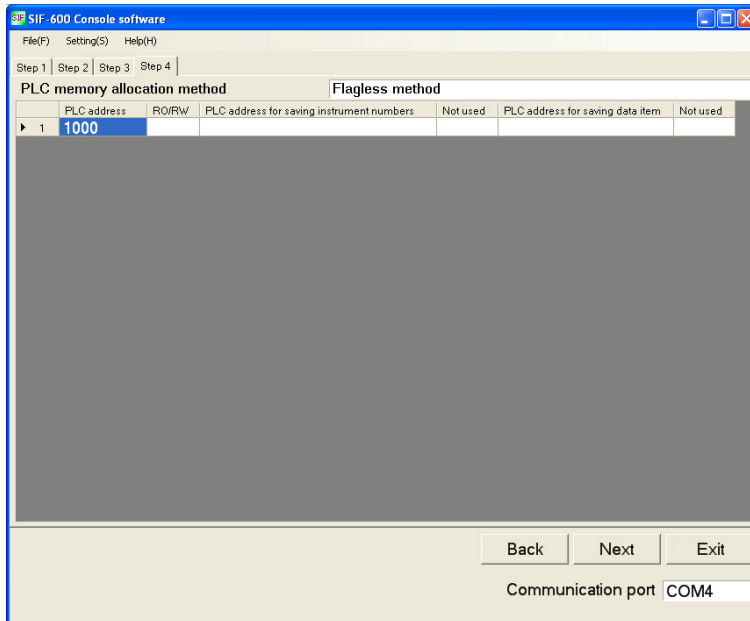

(Fig. 6.2.3-4)

PLC data section can be set.

Place the cursor at Data No.1, right-click and select [Edit data] from the menu. No.1 parameter setting display will be opened.

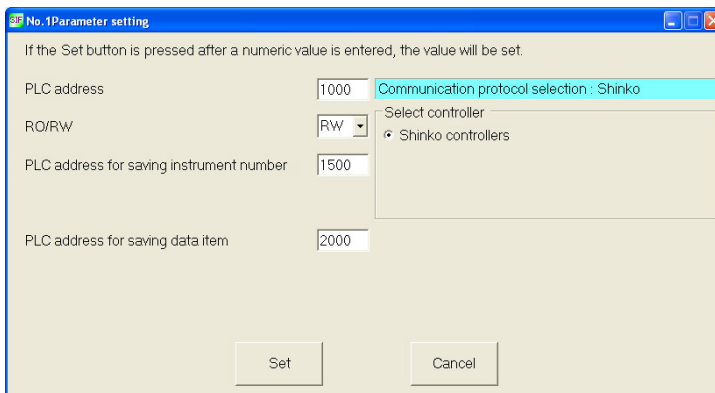

(Fig. 6.2.3-5)

Set the following.

Item	Setting
PLC address	1000
RO/RW	RW
PLC address for saving controller's instrument number	1500
PLC address for saving controller's data item	2000

Right-click and select [Add data] from the menu, then set other PLC data section in the same way.

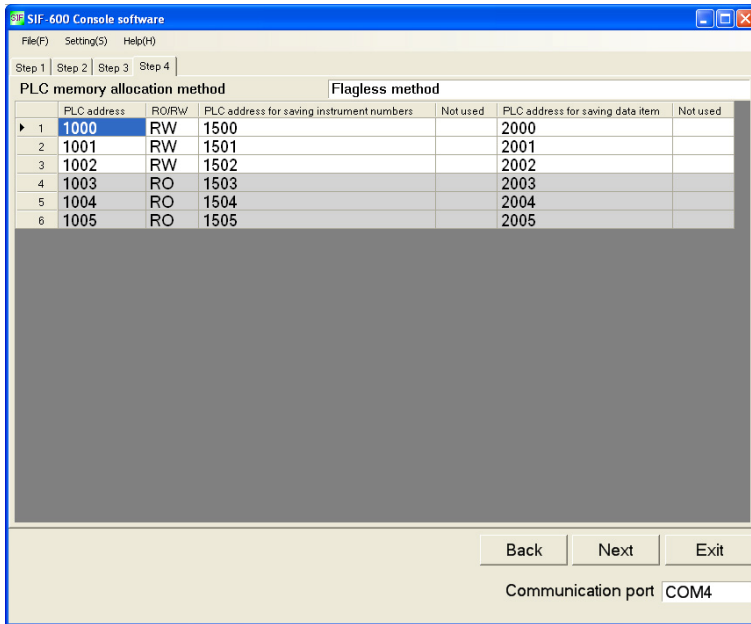

(Fig. 6.2.3-6)

Click [Next].

Step 5 Data transmission display will appear.

⑥ Step 5 Data transmission

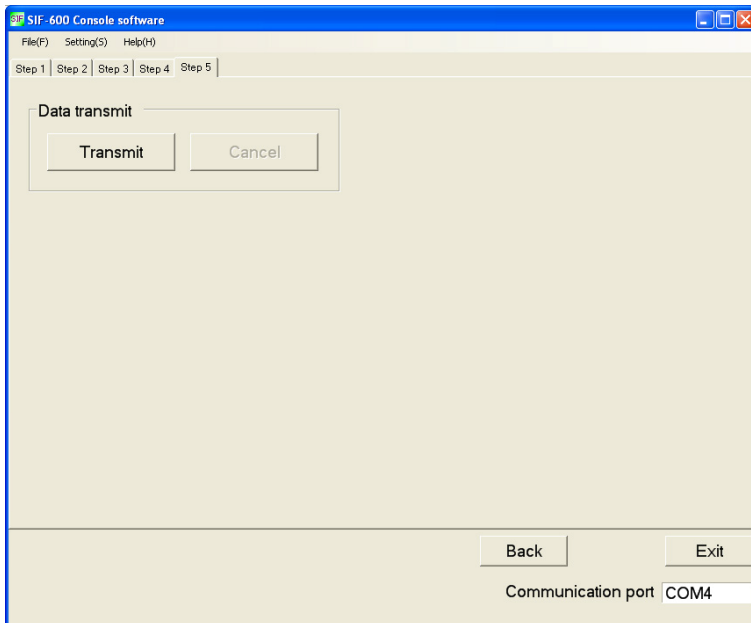

(Fig. 6.2.3-7)

Connect the USB communication cable CMB-001 (sold separately), and transmit the data.

Setup is now complete.

6.2.4 Setup Using the Fixed Address Method

With the Fixed address method, 20 units are fixed in the PLC register section.

RO (Read Only) data items are constantly updated.

For RW (Read/Write) data items, their settings are managed by the Set value change flag.

Data exchange occurs as follows.

RO (Read Only) data items: The SIF-600 constantly reads from the digital indicating controllers, and writes to the PLC register.

RW (Read/Write) data items: If the Set value change flag is set, the SIF-600 sends the setting/reading command for the predetermined data item to the connected controllers.

Connectable controller units are up to 20 units.

PLC register section occupies 20-Words per data item. (The same applies even when less than 20 units of controllers are connected.)

(1) Setup Items

Setup items on the console software are described in (Table 6.2.4-1).

(Table 6.2.4-1)

Setting item	Attribute	Contents	Setting example
System reference address	PLC register	Top PLC address allocated as the system section	500 (*1)
PLC data address	PLC register	Top PLC address allocated as the data section	1000 (*1)(*2)
RO/RW No.1 to 25	RO/RW command	Sets RO/RW command for each Data No. RO: Read Only data (PV, status, etc.) RW: Read/Write data (SV, alarm value, etc.)	No. 1 : RW No. 2 : RW No. 3 : RW No. 4 : RW No. 5 : RW No. 6 : RW No. 7 : RW No. 8 : RW No. 9 : RO (*3) No.10 : RO (*3) No.11 : RO (*3) No.12 : RO (*3)
Data item No.1 to 25	Reference	Sets Data item [communication reference number (1 to 25) of setting items] for each Data No.(*4) However, the Set value change flag number for each Data No. will be fixed.	No. 1 : 0001H No. 2 : 000BH No. 3 : 0002H No. 4 : 0028H No. 5 : 0051H No. 6 : 0071H No. 7 : 0052H No. 8 : 0078H No. 9 : 0080H No.10 : 0083H No.11 : 0090H No.12 : 0093H

(*1) 3-Words are occupied in the system section.

When setting the top data address, be careful not to duplicate the system addresses.

(*2) PLC data address setting is synchronized with the Reference address (p.62) in Parameter setting mode.

(*3) For RO/RW command, set RW first, then RO in that order only.

(*4) Notes when setting Data items

If Modbus protocol is selected in [Communication protocol selection], the SIF-600 will send the value (which 40001 of offset is subtracted from the reference number of data item) to the digital indicating controller via communication commands.

When setting Data items, take note of the following:

- If 'Shinko controllers' is selected in [Select controller]:

The Console software sets the value (to which 40001 of offset is automatically added to the reference number of Data item) on the SIF-600.

Setting range of reference number of Data item is 0000H to FFFFH, however, set the number within the range of 0000(0) to 63BEH [25534 (65535 - 40001)] so that the value (to which 40001 of offset is added) cannot exceed FFFFH (65535). See (Fig. 6.2.1-1) on p. 31.

(e.g.) For Data item 0001H: Write 1

For Data item 0080H: Write 128.

- If 'Other' is selected in [Select controller]:

The Console software sets the value on the SIF-600 without adding 40001 of offset to the reference number of Data item.

Set the value to which 40001 of offset is added.

Setting range of reference number of Data item is 0000H to FFFFH, however, set the number within the range of 9C41 [40001 (0+40001)] to FFFFH [65535 (25534+40001)] so that the value (to which 40001 of offset is added) cannot exceed FFFFH (65535). See (Fig. 6.2.1-2) on p. 31.

(e.g.) For Data item 0001H: Write 40002 (1+40001).

For Data item 0080H: Write 40129 (128+40001).

(2) PLC System Section

The following items in (Table 6.2.4-2) are allocated in the PLC system section.

(Table 6.2.4-2)

Item	Address	Function
PLC communication status, Controller communication status	System reference address	PLC communication status (Impossible to detect in case of no response): B0: Sum error B7: Other Controller communication status: B8: Negative acknowledgement B9: Checksum error B10: No response B15: Other
Update counter	System reference address +1	Counter is updated every time communication occurs. 0 to 65535 [Returns to 0 (zero) when 65535 is exceeded.] This is used to determine communication errors with the PLC.
Set value change flag	System reference address +2	Set value change flag section. If Set value change flag is set to any other value except 0 (zero), corresponding data item settings will be processed. After setting process is complete, the SIF-600 returns the Set value change flag to 0 (zero).

(3) PLC Register Section

If setup is carried out using "(1) Setup Items" as an example, the PLC register section will be described in (Table 6.2.4-3), and (Table 6.2.4-4).

(Table 6.2.4-3) System Section

PLC address	Contents
500	PLC communication status, Controller communication status
501	Update counter
502	Set value change flag

(Table 6.2.4-4) Data Section

Data No.	PLC address	RO/RW	Data item		Data amount	Set value change flag number (*3)
1	1000 to 1019	RW	0001	CH1 SV	20	Read: -2/Write: 2
2	1020 to 1039	RW	000B	CH1 Alarm 1 value	20	Read: -3/Write: 3
3	1040 to 1059	RW	0002	CH1 AT/Auto-reset Perform/Cancel	20	Read: -4/Write: 4
4	1060 to 1079	RW	0028	CH1 Control Allowed/Prohibited	20	Read: -5/Write: 5
5	1080 to 1099	RW	0051	CH2 SV	20	Read: -6/Write: 6
6	1100 to 1119	RW	0071	CH2 Alarm 1 value	20	Read: -7/Write: 7
7	1120 to 1139	RW	0052	CH2 AT/Auto-reset Perform/Cancel	20	Read: -8/Write: 8
8	1140 to 1159	RW	0078	CH2 Control Allowed/Prohibited	20	Read: -9/Write: 9
9	1160 to 1179	RO (*1)	0080	CH1 PV reading	20	Read: -10/Write: 10
10	1180 to 1199	RO (*1)	0083	CH1 Status flag reading	20	Read: -11/Write: 11
11	1200 to 1219	RO (*1)	0090	CH2 PV reading	20	Read: -12/Write: 12
12	1220 to 1239	RO (*1)	0093	CH2 Status flag reading	20	Read: -13/Write: 13
13	1240 to 1259	(*2)	(*2)		20	Read: -14/Write: 14
14	1260 to 1279	(*2)	(*2)		20	Read: -15/Write: 15
15	1280 to 1299	(*2)	(*2)		20	Read: -16/Write: 16
16	1300 to 1319	(*2)	(*2)		20	Read: -17/Write: 17
17	1320 to 1339	(*2)	(*2)		20	Read: -18/Write: 18
18	1340 to 1359	(*2)	(*2)		20	Read: -19/Write: 19
19	1360 to 1379	(*2)	(*2)		20	Read: -20/Write: 20
20	1380 to 1399	(*2)	(*2)		20	Read: -21/Write: 21
21	1400 to 1419	(*2)	(*2)		20	Read: -22/Write: 22
22	1420 to 1439	(*2)	(*2)		20	Read: -23/Write: 23
23	1440 to 1459	(*2)	(*2)		20	Read: -24/Write: 24
24	1460 to 1479	(*2)	(*2)		20	Read: -25/Write: 25
25	1480 to 1499	(*2)	(*2)		20	Read: -26/Write: 26

(*1) RO specified Data No. is Read Only item, and the Set value change flag is disabled.

(*2) PLC register section is occupied up to Data No.25 even if it is not used.

(*3) About Set value change flag number:

The Set value change flag number in the Fixed Address method is predetermined. It cannot be changed.

“Read” (Set value change flag number is negative) means reading data from the digital indicating controllers and writing to the PLC register section.

“Write” (Set value change flag number is positive) means reading data from the PLC register section and sending the setting command to the digital indicating controller.

When “-1” is written to the Set value change flag, the SIF-600 reads all setting item data (set in the PLC register section) from the controller, and writes it to the PLC register section.

With the Flexible Address and Multi Address methods, the Set value change flag 1 (positive number) operates the SIF-600 to read all setting item data (set in the PLC register section) from controllers, and to write it to the PLC register section.

Take note that only the Fixed Address method uses a negative Set value change flag number.

Using “(1) Setup Items (p.51)” as an example, setup procedures on the console software will be described.

① **Starting the console software**

From the start menu, select [All Programs] - [SHINKO TECHNOS] - [SWS-SIF01M], and click. The SIF-600 console software will start, and Step 1 Startup parameters selection display will appear.

② **Step 1 Startup parameters selection**

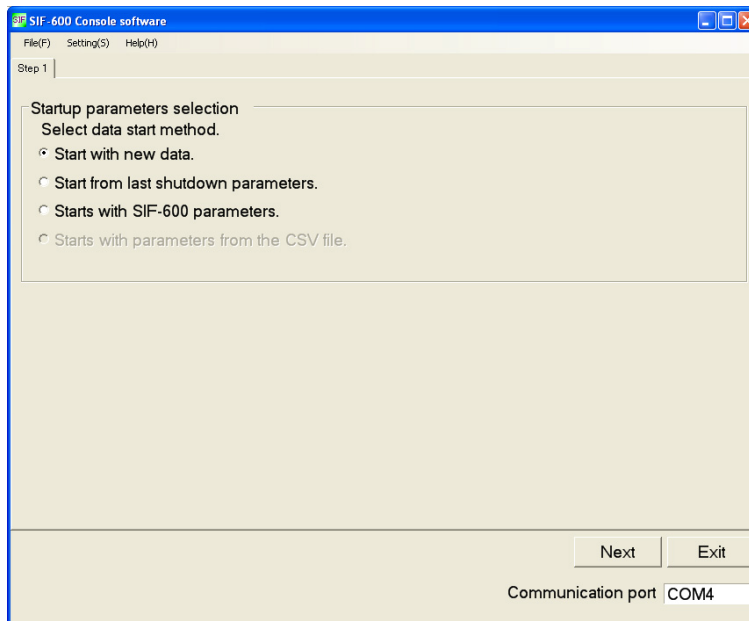

(Fig. 6.2.4-1)

Select a data start method, and click [Next]. Step 2 PLC memory allocation method display will appear.

③ **Step 2 PLC memory allocation method**

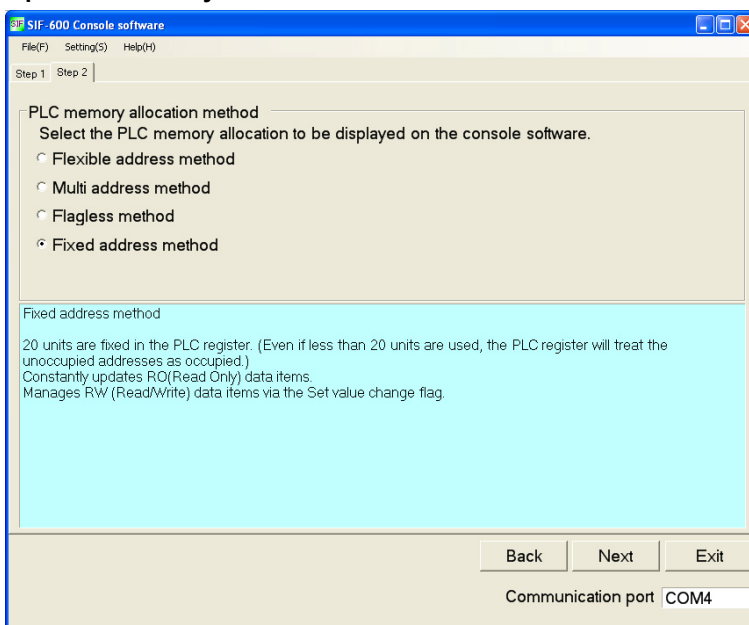

(Fig. 6.2.4-2)

Item	Setting
PLC memory allocation method	Fixed address method

Select a PLC memory allocation method, and click [Next].
Step 3 System data setting display will appear.

④ Step 3 System data setting

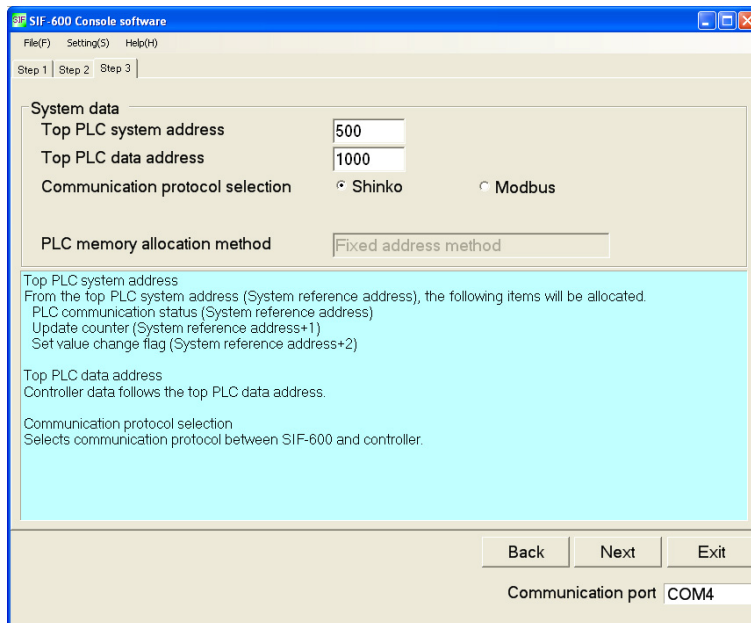

(Fig. 6.2.4-3)

- Top PLC system address (In the system addresses, communication status of the PLC and controller, update counter, etc. are allocated.)
- Top PLC data address (In the data addresses, RO/RW, data item, etc. are allocated.)

Item	Setting
Top PLC system address	500 (*)
Top PLC data address	1000 (*)

(*) 3-Words are occupied in system section.

When setting the top PLC data address, be careful not to duplicate the PLC system addresses.

Set the top PLC system address and top PLC data address, click [Next].
Step 4 PLC data setting display will appear.

⑤ Step 4 PLC data setting

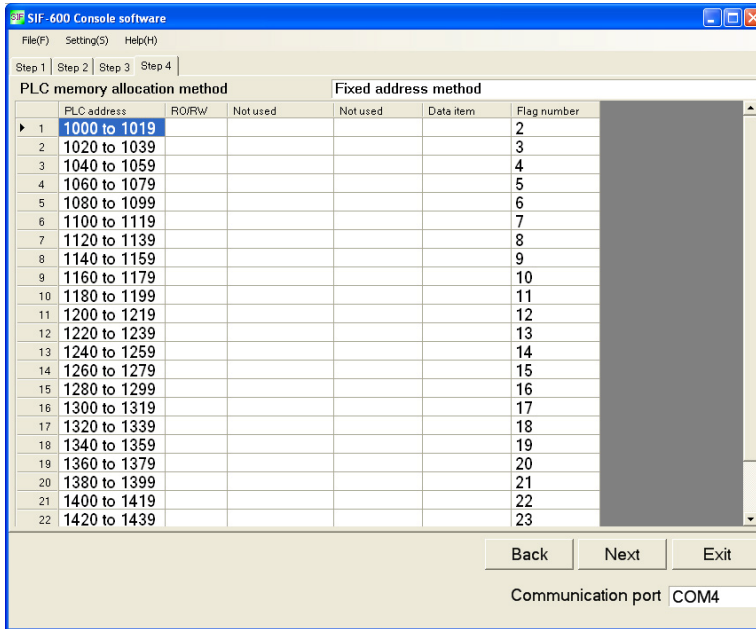

(Fig. 6.2.4-4)

PLC data section can be set.

20-Words are occupied for every Data No. (The same applies even when the number of connected units is less than 20.)

Flag number is also fixed.

Place the cursor at Data No.1, right-click and select [Edit data] from the menu.

No.1 parameter setting display will be opened.

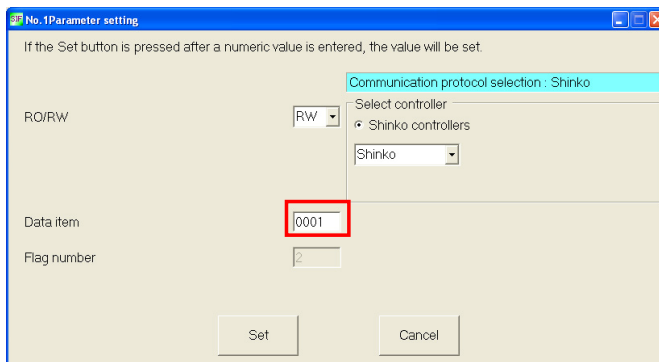

(Fig. 6.2.4-5)

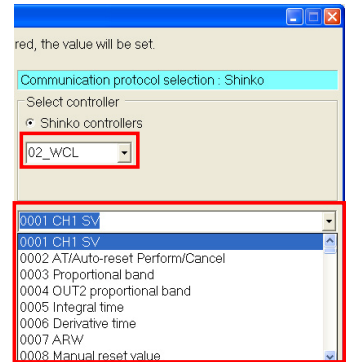

(Fig. 6.2.4-6)

Set the following.

Item	Setting
RO/RW	RW
Data item (*)	0001

(*) There are 2 methods in data item setting.

1. Direct input (Fig. 6.2.4-5)

Set the reference number using decimal number(s).

Console software will set the reference number (converted to hexadecimal number) on the SIF-600.

2. Selects from the data item list. (Fig. 6.2.4-6)

If a controller model is selected in [Select controller], the pull-down box will appear on the right side of the data item.

If the button on right end is clicked, data item list will appear.

Select from the list.

Right-click and select [Edit data] from the menu, then set other PLC data section in the same way.

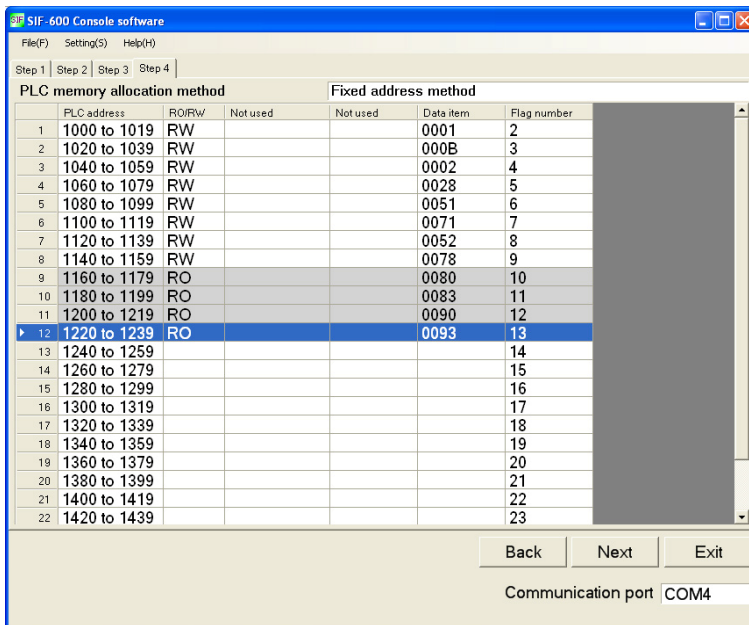

(Fig. 6.2.4-7)

Click [Next].
Step 5 Data transmission display will appear.

⑥ Step 5 Data transmission

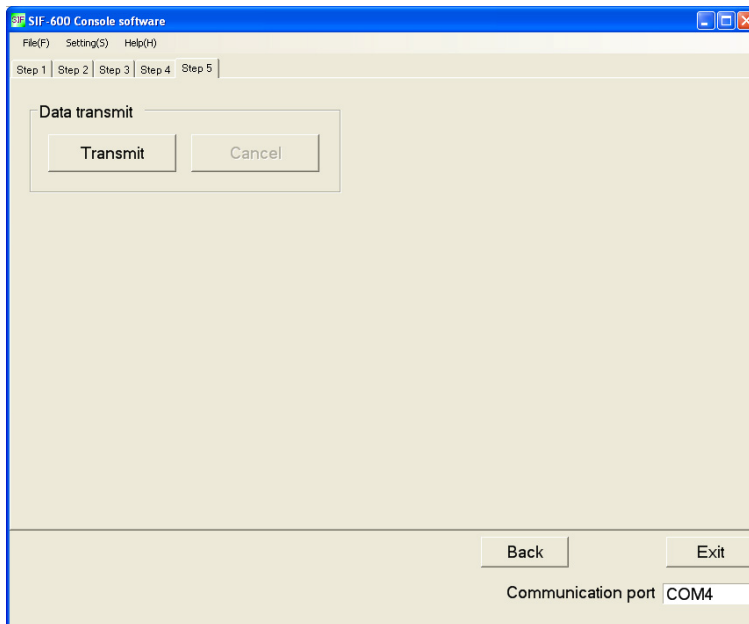

(Fig. 6.2.4-8)

Connect the USB communication cable CMB-001 (sold separately), and transmit the data.
Setup is now complete.

6.3 Setup in Parameter Setting Mode

Default value is set as shown in (Table 6.3-1) below.

If the users' specification is the same as the default value of the SIF-600, or if setup has already been complete, it is not necessary to set up the SIF-600. Proceed to Section "6.4 Setup of the PLC" (pages 63 to 73).

(Table 6.3-1)

Setting item	Factory default value
PLC Memory allocation method	Fixed address method
Controller Communication protocol	Shinko protocol
Controller Communication speed	9600 bps
Controller Data length	7 bits
Controller Parity	Even
Controller Stop bit	1 bit
PLC Model	Mitsubishi MELSEC D register QR/QW command
PLC Instrument number	0
PLC Communication speed	9600 bps
PLC Data length	7 bits
PLC Parity	Even
PLC Stop bit	1 bit
Number of connected controllers (*1)	1 unit
Reference address (*1) (*2)	03E8H (1000)
Auto-light function	Disabled
Indication time	00.00 (Remains lit)

(*1) Indicated when Fixed address method is selected in [PLC memory allocation method] on the console software.

(*2) Reference address can be set in units of 500 in hexadecimal.



(e.g.) 500 (01F4H)

1000 (03E8H)

6.3.1 Key Operation Flowchart in Parameter Setting Mode

To enter Parameter setting, press the  key for 3 seconds in Communication mode.

To communicate with the PLC and digital indicating controllers, set the PLC memory allocation method, PLC model, communication parameters of the controller and PLC, etc. in Parameter setting mode.

Use the  or  key for settings (selections), and use the  key to register the set values.



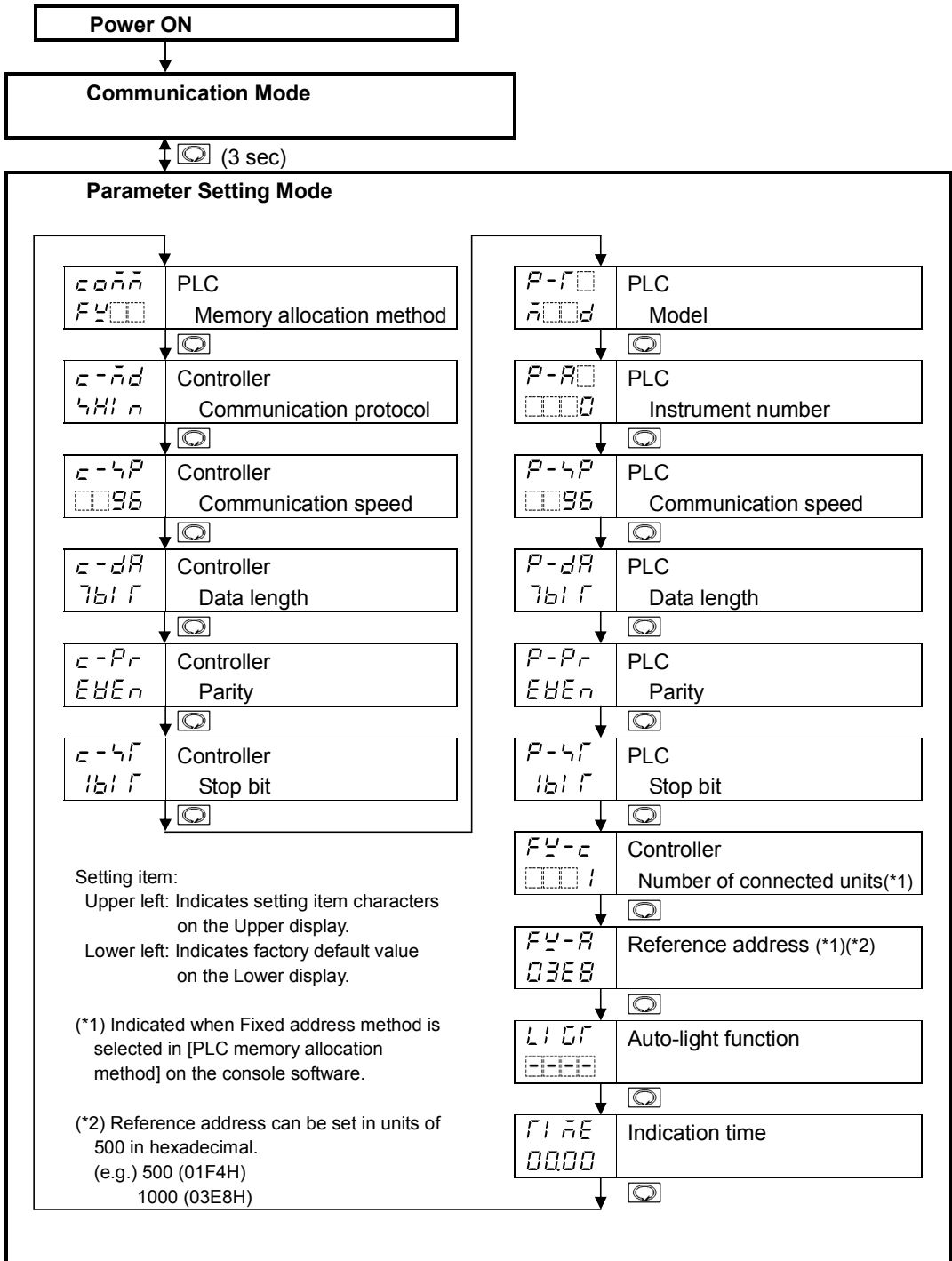



To return to Communication mode, hold down the  key for 3 seconds.



6.3.2 Setting Items in Parameter Setting Mode

Displays	Name, Function, Setting Range	Factory Default Value															
<i>c0ññ</i> <i>Fy□□</i>	PLC Memory allocation method	Fixed address method															
	<ul style="list-style-type: none"> Indicates a method selected in [PLC memory allocation method] on the console software. <p>For the PLC memory allocation methods, see the (Table 6.3.2-1) below.</p> <p>(Table 6.3.2-1)</p> <table border="1"> <thead> <tr> <th>Displays</th> <th>PLC memory allocation</th> <th>Contents</th> </tr> </thead> <tbody> <tr> <td><i>Fb□□</i></td> <td>Flexible address method</td> <td>Constantly updates RO (Read Only) data items. Manages RW (Read/Write) data item settings via the Set value change flag.</td> </tr> <tr> <td><i>ñR□□</i></td> <td>Multi address method (*)</td> <td>Block communication command (multiple data communication command in Modbus protocol) can be used. Constantly updates RO (Read Only) data items. Manages RW (Read/Write) data item settings via the Set value change flag.</td> </tr> <tr> <td><i>FL□□</i></td> <td>Flagless method</td> <td>Constantly updates RO (Read Only) data items. Manages RW (Read/Write) data item settings without using the Set value change flag.</td> </tr> <tr> <td><i>Fy□□</i></td> <td>Fixed address method</td> <td>20 units are fixed in the PLC register section. Constantly updates RO (Read Only) data items. Manages RW (Read/Write) data item settings via the Set value change flag.</td> </tr> </tbody> </table> <p>(*) This method can be used for Shinko Multi-point temperature control system C series or Temperature control boards.</p>		Displays	PLC memory allocation	Contents	<i>Fb□□</i>	Flexible address method	Constantly updates RO (Read Only) data items. Manages RW (Read/Write) data item settings via the Set value change flag.	<i>ñR□□</i>	Multi address method (*)	Block communication command (multiple data communication command in Modbus protocol) can be used. Constantly updates RO (Read Only) data items. Manages RW (Read/Write) data item settings via the Set value change flag.	<i>FL□□</i>	Flagless method	Constantly updates RO (Read Only) data items. Manages RW (Read/Write) data item settings without using the Set value change flag.	<i>Fy□□</i>	Fixed address method	20 units are fixed in the PLC register section. Constantly updates RO (Read Only) data items. Manages RW (Read/Write) data item settings via the Set value change flag.
Displays	PLC memory allocation	Contents															
<i>Fb□□</i>	Flexible address method	Constantly updates RO (Read Only) data items. Manages RW (Read/Write) data item settings via the Set value change flag.															
<i>ñR□□</i>	Multi address method (*)	Block communication command (multiple data communication command in Modbus protocol) can be used. Constantly updates RO (Read Only) data items. Manages RW (Read/Write) data item settings via the Set value change flag.															
<i>FL□□</i>	Flagless method	Constantly updates RO (Read Only) data items. Manages RW (Read/Write) data item settings without using the Set value change flag.															
<i>Fy□□</i>	Fixed address method	20 units are fixed in the PLC register section. Constantly updates RO (Read Only) data items. Manages RW (Read/Write) data item settings via the Set value change flag.															
<i>c-ñd</i> <i>4H1 n</i>	Controller Communication protocol	Shinko protocol															
	<ul style="list-style-type: none"> Selects communication protocol for communication with the controller. <p>• Selection item: <i>4H1 n</i>: Shinko Protocol <i>ñodA</i>: Modbus ASCII <i>ñodr</i>: Modbus RTU</p>																
<i>c-4P</i> <i>□□96</i>	Controller Communication speed	9600 bps															
	<ul style="list-style-type: none"> Selects communication speed for communication with the controller. <p>• Selection item: <i>□□96</i>: 9600 bps <i>□192</i>: 19200 bps <i>□384</i>: 38400 bps</p>																
<i>c-dA</i> <i>7b1 f</i>	Controller Data length	7 bits															
	<ul style="list-style-type: none"> Selects the data length for communication with the controller. <p>• Selection item: <i>7b1 f</i>: 7 bits <i>8b1 f</i>: 8 bits</p>																
<i>c-Pr</i> <i>E8En</i>	Controller Parity	Even															
	<ul style="list-style-type: none"> Selects the parity for communication with the controller. <p>• Selection item: <i>nonE</i>: No parity <i>E8En</i>: Even <i>odd□</i>: Odd</p>																

Displays	Name, Function, Setting Range	Factory Default Value
<i>c-4f</i> <i>1b1f</i>	Controller Stop bit	1 bit
	<ul style="list-style-type: none"> • Selects stop bit for communication with the controller. • Selection range: <i>1b1f</i> : 1 bit <i>2b1f</i> : 2 bits 	
<i>P-r</i> <i>n00d</i>	PLC Model	Mitsubishi MELSEC D register QR/QW command
	<ul style="list-style-type: none"> • Selects a PLC model and its communication type. • Selection item: <i>n00d</i>: Mitsubishi MELSEC D register QR/QW command <i>n00r</i>: Mitsubishi MELSEC R register QR/QW command <i>a000</i>: Omron SYSMAC CJ series <i>k000</i>: Keyence KV <i>y000</i>: Yokogawa FA-M3 <i>f000</i>: Fuji MICREX-SX series 	
<i>P-A</i> <i>0000</i>	PLC Instrument number	0
	<ul style="list-style-type: none"> • Sets instrument number of the PLC to be connected. • Setting range: 0 to 99 	
<i>P-4P</i> <i>0096</i>	PLC Communication speed	9600 bps
	<ul style="list-style-type: none"> • Selects communication speed for communication with the PLC. • Selection item: <i>0096</i>: 9600 bps <i>0192</i>: 19200 bps <i>0384</i>: 38400 bps 	
<i>P-dA</i> <i>7b1f</i>	PLC Data length	7 bits
	<ul style="list-style-type: none"> • Selects data length for communication with the PLC. • Selection item: <i>7b1f</i> : 7 bits <i>8b1f</i> : 8 bits 	
<i>P-Pf</i> <i>EVEN</i>	PLC Parity bit	Even
	<ul style="list-style-type: none"> • Selects parity bit for communication with the PLC. • Selection item: <i>nonE</i>: No parity <i>EVEN</i>: Even <i>odd</i>: Odd 	
<i>P-4f</i> <i>1b1f</i>	PLC Stop bit	1 bit
	<ul style="list-style-type: none"> • Selects stop bit for communication with the PLC. • Selection item: <i>1b1f</i> : 1 bit <i>2b1f</i> : 2 bits 	

Displays	Name, Function, Setting Range	Factory Default Value																											
FY-C 	Controller Number of connected units	1 unit																											
	<ul style="list-style-type: none"> • Sets the number of controllers to be connected. Available when Fixed address method is selected in [PLC memory allocation method] on the console software. • Setting range: 1 to 20 units 																												
FY-R 	Reference address	03E8H (1000)																											
	<ul style="list-style-type: none"> • Sets the register reference address for data reading/writing. Available when Fixed address method is selected in [PLC memory allocation method] on the console software. • Setting range: 0000H to FFDCH (0 to 65500) <p>Reference address is synchronized with PLC data address (p.51) of the console software.</p> <p>PLC data address on the console software can be set randomly. However, reference addresses are set in units of 500 using hexadecimal numbers as in (Table 6.3.2-2).</p> <p>(Table 6.3.2-2)</p> <table border="1"> <thead> <tr> <th>Decimal</th> <th>Hexadecimal</th> </tr> </thead> <tbody> <tr><td>0</td><td>0000H</td></tr> <tr><td>500</td><td>01F4H</td></tr> <tr><td>1000</td><td>03E8H</td></tr> <tr><td>1500</td><td>05DCH</td></tr> <tr><td>2000</td><td>07D0H</td></tr> <tr><td>2500</td><td>09C4H</td></tr> <tr><td>3000</td><td>0BB8H</td></tr> <tr><td>3500</td><td>0DACH</td></tr> <tr><td>4000</td><td>0FA0H</td></tr> <tr><td>4500</td><td>1194H</td></tr> <tr><td>5000</td><td>1388H</td></tr> <tr><td>5500</td><td>157CH</td></tr> <tr><td>6000</td><td>1770H</td></tr> </tbody> </table>		Decimal	Hexadecimal	0	0000H	500	01F4H	1000	03E8H	1500	05DCH	2000	07D0H	2500	09C4H	3000	0BB8H	3500	0DACH	4000	0FA0H	4500	1194H	5000	1388H	5500	157CH	6000
Decimal	Hexadecimal																												
0	0000H																												
500	01F4H																												
1000	03E8H																												
1500	05DCH																												
2000	07D0H																												
2500	09C4H																												
3000	0BB8H																												
3500	0DACH																												
4000	0FA0H																												
4500	1194H																												
5000	1388H																												
5500	157CH																												
6000	1770H																												
LI OF 	Auto-light function	Disabled																											
	<ul style="list-style-type: none"> • Selects Auto-light function Enabled/Disabled. • Selection item:  Disabled  Enabled 																												
FI AE 	Indication time	00.00 (Remains lit)																											
	<ul style="list-style-type: none"> • Sets the indication time of the displays from the final key operation till displays go off in Communication mode. (Status indicators remain lit.) Displays remain lit when setting to 00.00. Displays light when any key is pressed while in unlit status. • Setting range: 00.00 (Remains lit) 00.01 to 60.00 (Minutes.Seconds) 																												

6.4 Setup of the PLC

6.4.1 Setup of Mitsubishi PLC

(1) Setup of Calculator link unit (AJ71UC24)

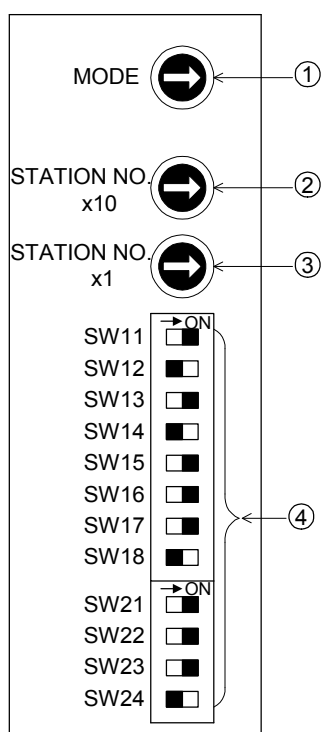

(Fig. 6.4.1-1)

- ① Sets the transmission control procedure (protocol) and RS-422/RS-232C control procedure.
Set to 8 (Format 4).
- ② Sets the instrument number of the tens digit (x10).
- ③ Sets the instrument number of the ones digit (x1).
- ④ Sets the transmission specifications.
See (Table 6.4.1-1).
Set the items, excluding baud rate, to .

(Table 6.4.1-1)

Setting switch	Setting item	Setting switch ON	Setting switch OFF
SW11	Main channel	RS-422	RS-232C
SW12	Data bits	8 bits	7 bits
	Baud rate	9600 bps	19200 bps
SW13	Transmission speed	ON	OFF
SW14		OFF	ON
SW15		ON	ON
SW16	Parity Yes/No	Yes	No
SW17	Even/Odd parity	Even	Odd
SW18	Stop bits	2 bits	1 bit
SW21	Checksum Yes/No	Yes	No
SW22	Writing during RUN	Possible	Impossible
SW23	Calculator link/Multi-drop link	Calculator link	Multi-drop link
SW24	Not used		

(2) Setup of the Calculator Link Unit (A1SJ71UC24-R4)

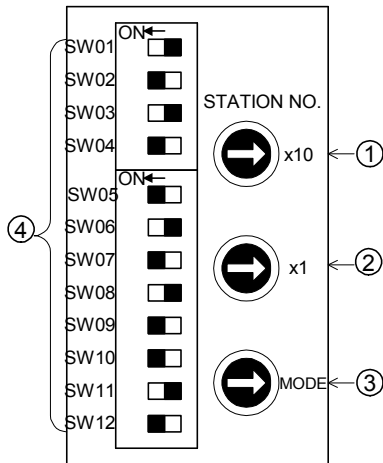

(Fig. 6.4.1-2)

- ① Sets the instrument number of the tens digit (x10).
- ② Sets the instrument number of the ones digit (x1).
- ③ Sets the transmission control procedure (protocol) and RS-422/RS-232C control procedure. Set to 8 (Format 4).
- ④ Sets the transmission specifications. See (Table 6.4.1-2). Set the items, excluding baud rate, to .

(Table 6.4.1-2)

Setting switch	Setting item	Setting switch ON	Setting switch OFF
SW01	Not used		
SW02	Calculator link/Multi-drop link	Calculator link	Multi-drop link
SW03	Not used		
SW04	Writing during RUN	Possible	Impossible
	Baud rate	9600 bps	19200 bps
SW05	Transmission speed	ON	OFF
SW06		OFF	ON
SW07		ON	ON
SW08	Data bits	8 bits	7 bits
SW09	Parity Yes/No	Yes	No
SW10	Even/Odd parity	Even	Odd
SW11	Stop bits	2 bits	1 bit
SW12	Sum check Yes/No	Yes	No

(3) Setup of the Micro PLC (FX series)

By programming, set the station number (0), communication of non procedure, and communication (communication format D8120) of the calculator link with the dedicated protocol.

FX series can be set using either the program or the parameter setting software (GX Developer). However, when setting is needed simultaneously using both, setting by the GX Developer has priority. For the setting method, refer to the User's Manual (Communication control) for the FX series.

● Setting via the Parameter setting software (GX Developer)

Select [Parameter setting] – [PLC system (2)], and set the following items.

Protocol: Dedicated protocol communication, Data length: 7 bits, Parity: Even, Stop bit: 1 bit, Transmission speed: 9600 bps, H/W type: RS-485, Sum check: Added, Transmission control procedure: Format 4 (with CR, LF), Station number setting: 00H, Time out judge time: 1 x 10ms

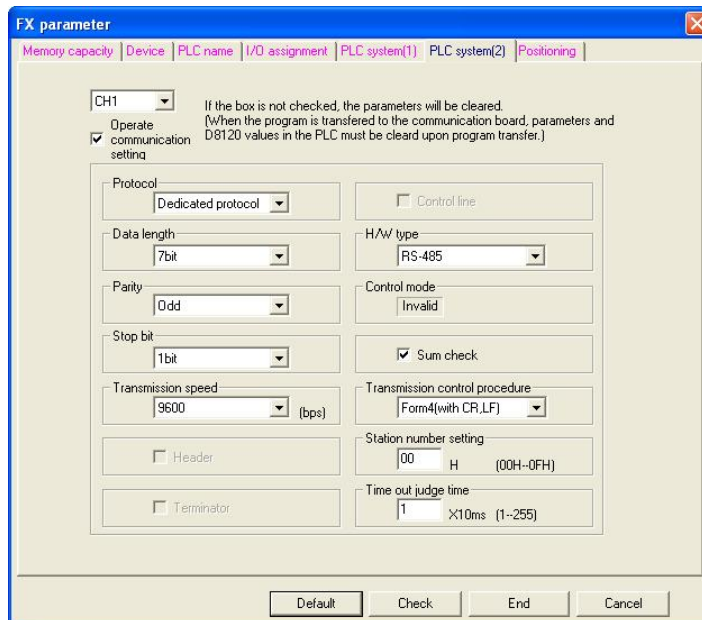

(Fig. 6.4.1-3)

● Setting by programming

- **Specification of communication format D8120** (Set the items to except the baud rate.)
Communication format is used to determine the settings of (Table 6.4.1-3) below, and it can be set by programming to the special data register (D8120) of the PLC.
When settings are changed, be sure to turn the power supply to the PLC OFF, then ON again, otherwise the changed data will not be valid.

(4) Setup of the Serial Communication Module (QJ71C24)

Connect a personal computer on which the Parameter setting software (GX Developer) is installed, perform settings such as transmission speed, transmission specifications and communication protocol, and set up the unit using the PC writing function.

For the setting method, refer to the User's Manual (Basic) for the Serial Communication Module.

- Setting from the Parameter setting software (GX Developer):
 Select [Parameter setting] - [I/O assignment], and set the following items.
 Type: "Intelli", Model: QJ71C24, Points: 32

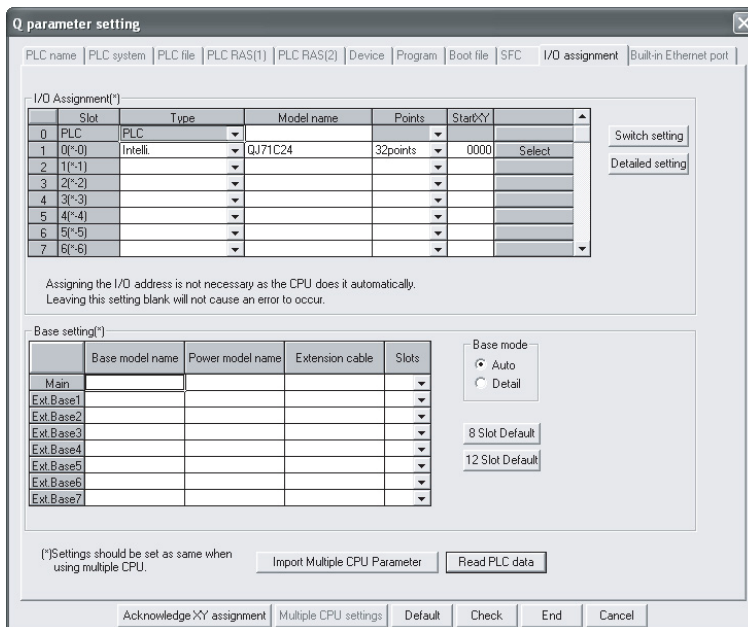

(Fig. 6.4.1-4)

Switch Setting for I/O and Intelligent Function Module

Set the following items.

- Transmission setting (Action setting: Independent, Data bits: 7, Parity bits: Yes (Even), Stop bits: 1, Sum check code: Yes, Writing during RUN: Allowed, Setting change: Allowed)
- Transmission speed setting (9600 or 19200 bps) (9600 bps is used as an example.)
- Communication protocol setting (Format 4)

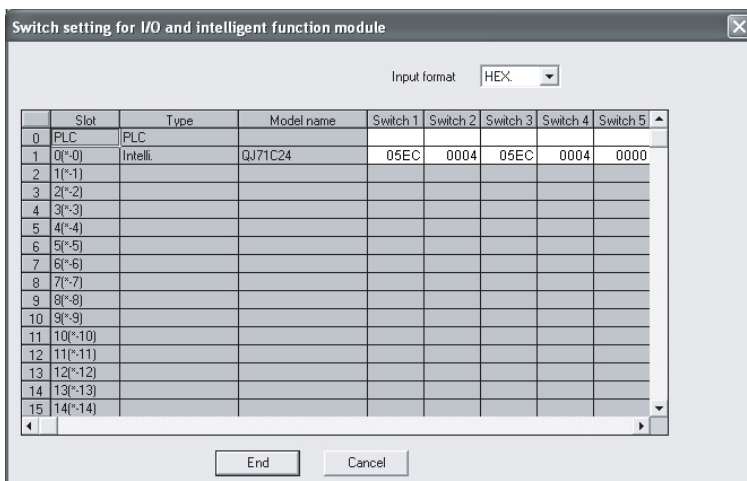

(Fig. 6.4.1-5)

6.4.2 Setup of Omron PLC

Setup of the Serial Communication Unit (CS1W-SCU21-V1, CJ1W-SCU21, CJ1W-SCU41)

For setting methods, refer to User's Manual (Man. No. SBCE-300G) for Serial communication unit.

- Turn "TERM" (terminator ON/OFF switch) ON, and set "WIRE" (2-wire/4-wire switch) to 4.
[This setting is only for the "CJ1W-SCU41".

For the CS1W-SCU21-V1, CJ1W-SCU21, go to step (2).]

- Connect to a PC, and start the CX-Programmer.
- Create I/O table of the PC while off-line (Fig. 6.4.2-1).
Select [CS/CJ CPU SIO Unit] – [Serial Communications Unit] – [Unit number].
- Set the allocation DM of the serial communication unit. (Fig. 6.4.2-2)
Set the allocation DM by programming the on-line connection and action mode.
(e.g.) When installing the serial communication unit next to the CPU unit, and when UNIT No. is set to "0":

D30000 is set to 8500H (random setting, host link communication, Data bit: 7 bits,

Stop bit: 2, Parity: Yes/Even).

D30001 is set to 0007H (19200 bps).

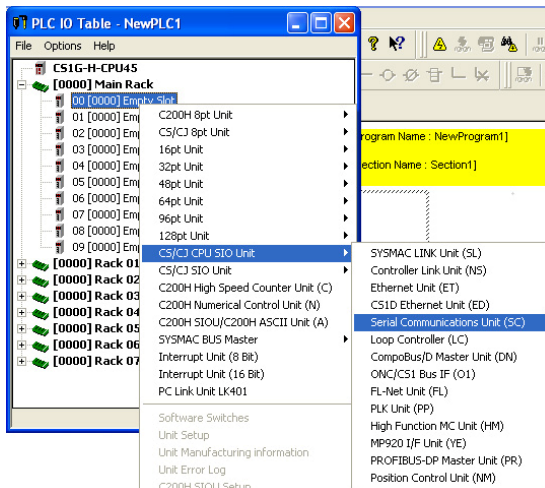

(Fig. 6.4.2-1)

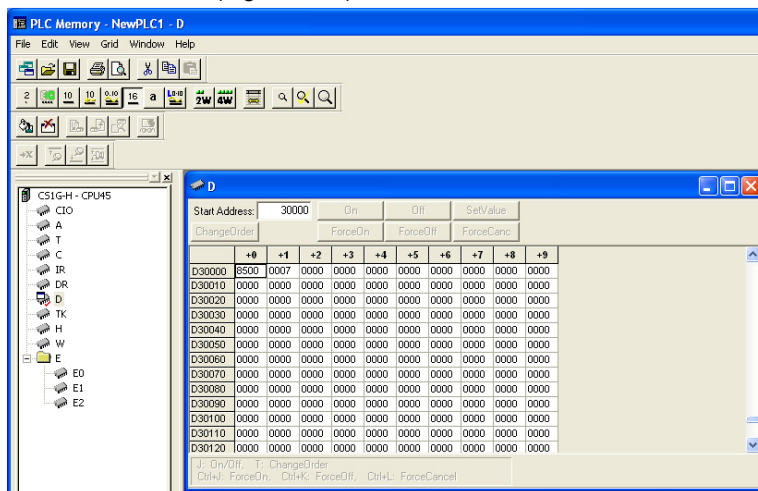

(Fig. 6.4.2-2)

- Transmit the following to the CPU unit.
Transmit the program, PC system setting and I/O table by clicking "Transmit [PC → PC]".

6.4.3 Setup of Keyence PLC

Setup of the Serial Communication Unit (KV-L20V)

For setting methods, refer to User's Manual for Serial communication unit KV-L20V.

(1) Set the terminator using the terminator selection switch (TERM.)

When using Port 2 for RS-232C, set it to OFF.

When using Port 2 for RS-422A and RS-485, set it to ON.

(2) Connect a PC, and start the KV STUDIO (Ver.4 or later), and start the Unit Editor.

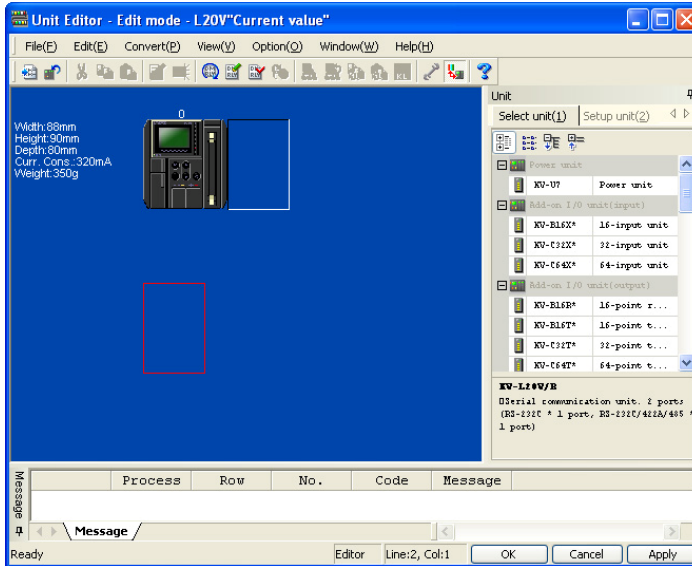

(Fig. 6.4.3-1)

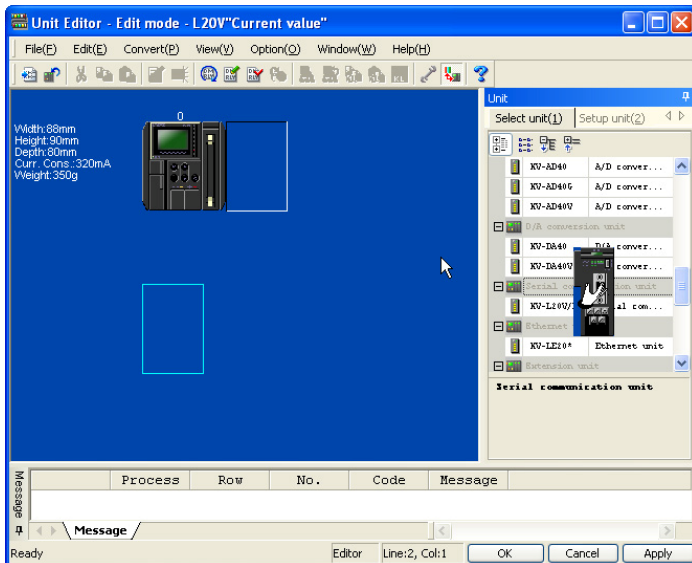

(Fig. 6.4.3-2)

Select the KV-L20V on the Unit Editor, and allocate the leading DM number and the leading relay number.

(3) Set details of the KV-L20V in the Unit location section.

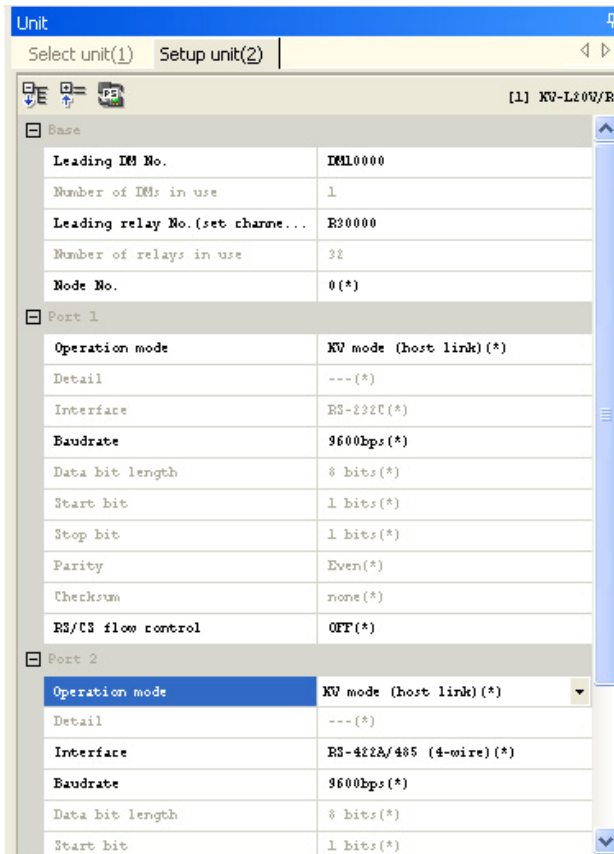

(Fig. 6.4.3-3)

The setting items in gray are fixed, so they cannot be set.
Set the following setting items.

Setting item	Set value
Operation mode	KV mode (Host link)
Baud rate	9600, 19200, 38400 bps (Must be specified.)

(4) Press the Enter Key.

The setting contents will be registered.

(5) Click [OK].

The Unit Editor will be closed.

6.4.4 Setup of Yokogawa PLC

Setup of the Personal Computer Link Module (F3LC11-2N)

- (1) Sets the Station number setting switch (tens digit). (*)
- (2) Sets the Station number setting switch (ones digit). (*)
- (3) Sets the Terminator switch. Select "4-WIRE".
- (4) Sets the Transmission speed setting switch. For baud rate, set it to either 9600 bps or 19200 bps.
- (5) Sets the Data setting switch. Refer to (Table 6.4.4-1).
Set to .

(*) For the Station number setting switch, set a value larger than 0 for the ones digit and tens digit.
Avoid 0 (zero) because 0 for the ones and tens digits are CPU unit numbers.

(Table 6.4.4-1)

Number	Function	Setting switch OFF	Setting switch ON
1	Data bit	7 bits	8 bits
2	Parity	No	Yes
3	Odd/Even parity	Odd	Even
4	Stop bit	1 bit	2 bits
5	Checksum	No	Yes
6	End of text (CR)	No	Yes
7	Protection function	No	Yes
8	OFF		

6.4.5 Setup of Fuji PLC

Setup of General-purpose Communication Module

For setting methods, refer to User's Manual for MICREX-SX series, General-purpose Communication Module.

NP1L-RS1:

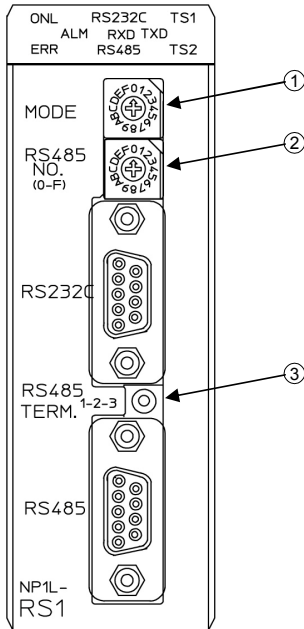

(Fig. 6.4.5-1)

① Set the port (RS-232C or RS-485), for connecting to the SIF-600, to Loader (*) using the MODE switch.

(*) If the port is set to Loader, communication specifications will be fixed as follows.

Speed: 38400 bps
 Data length: 8 bits
 Stop bit: 1
 Parity: Even

② When using the RS-485, set the RS-485 station number using the RS 485 NO. switch.

③ When using the RS-485, set to "4-wire Terminator ON" using the RS 485 TERM switch.

NP1L-RS2:

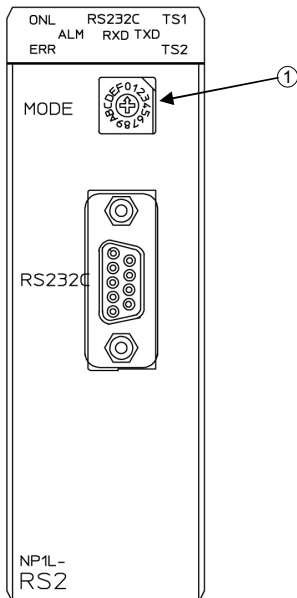

(Fig. 6.4.5-2)

① Set the port (RS-232C), for connecting to the SIF-600, to Loader (*) using the MODE switch.

(*) If the port is set to Loader, communication specifications will be fixed as follows.

Speed: 38400 bps
 Data length: 8 bits
 Stop bit: 1
 Parity: Even

NP1L-RS4

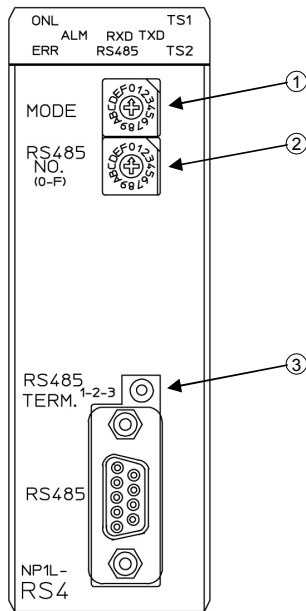

(Fig. 6.4.5-3)

- ① Set the port (RS-485), for connecting to the SIF-600, to Loader (*) using the MODE switch.

(*) If the port is set to Loader, communication specifications will be fixed as follows.

Speed: 38400 bps

Data length: 8 bits

Stop bit: 1

Parity: Even

- ② Set the RS-485 station number using the RS 485 NO. switch.
- ③ Set to "4-wire Terminator ON" using the RS-485 TERM switch.

6.5 Setup of Digital Indicating Controllers

For setup of the digital indicating controller, refer to the instruction manual for each digital indicating controller.

(Table 6.5-1) shows a setting example.

(Table 6.5-1)

Setting item	Setting
Communication protocol	Select the communication protocol to match the SIF-600 setting.
Instrument number	<p>The setting range changes depending on the communication protocol.</p> <ul style="list-style-type: none"> • For Shinko protocol, set an instrument number within a range of 0 to 95, avoiding duplication. • For Modbus protocol, set an instrument number within a range of 1 to 95, avoiding duplication. <p>If Fixed address method is selected in [PLC memory allocation method] via console software, set as follows.</p> <ul style="list-style-type: none"> • For Shinko protocol, set consecutive instrument numbers (0 to 19). • For Modbus protocol, set consecutive instrument numbers (1 to 20).
Communication speed	Select either 9600 bps, 19200 bps or 38400 bps to match the setting of the SIF-600.
Data length	Select either 7 or 8 bits to match the setting of the SIF-600.
Parity	Select either No parity, Even or Odd to match the setting of the SIF-600.
Stop bit	Select either 1 or 2 bits to match the setting of the SIF-600.

7. Operation

Operation will be explained using respective PLC memory allocation methods.

7.1 Turn the Power ON

Turn the power supply ON starting with the PLC, digital indicating controllers, then the SIF-600.

[\bar{h} / F \square] is indicated for approx. 5 sec. on the Displays, and the unit enters Communication mode.

Indications in Communication mode are displayed as follows.

Upper Display	\square	\square	\square	\square	Contents
PLC manufacturer	\bar{h}	d			Mitsubishi D Register
	\bar{h}	r			Mitsubishi R Register
	o	\square			Omron Corp.
	t	\square			Keyence Corp.
	y	\square			Yokogawa Electric Corp.
	F	\square			Fuji Electric Co., Ltd.
Communication status with the PLC					Segments below are indicated in 0.5 second cycles clockwise. $\bar{h} \rightarrow \bar{h}' \rightarrow \bar{h}'' \rightarrow \bar{h}''' \rightarrow \bar{h}'''' \rightarrow \bar{h}'''''$ Subsequently repeated.
Communication status with the controller					
Lower Display	\square	\square	\square	\square	Contents
PLC memory allocation method	F	b			Flexible address method
	\bar{h}	R			Multi address method
	F	L			Flagless method
	F	\bar{u}			Fixed address method
					Unlit

Indications of communication errors are shown below.

Upper Display	<input type="checkbox"/>	<input type="checkbox"/>	<input type="checkbox"/>	<input type="checkbox"/>	Contents
PLC manufacturer	\bar{n}	d			Mitsubishi D register
	\bar{n}	r			Mitsubishi R register
	o	\square			Omron Corp.
	t	\square			Keyence Corp.
	y	\square			Yokogawa Electric Corp.
	F	\square			Fuji Electric Co., Ltd.
Communication status with the PLC				ε	ε flashes in 0.5 second cycles. After a communication error occurs, error indication continues for 10 seconds. Unlit when the unit reverts to normal.
Communication status with the controller				ε	
Lower Display	<input type="checkbox"/>	<input type="checkbox"/>	<input type="checkbox"/>	<input type="checkbox"/>	Contents
PLC memory allocation method	F	b			Flexible address method
	\bar{n}	A			Multi address method
	F	L			Flagless method
	F	u			Fixed address method
PLC side communication error code (Table 7.1-1)				(*1)	Error codes i to $\bar{5}$ flashes in 0.5 second cycles. When error codes are duplicated, codes flash in numeric order every 1 second. After a communication error occurs, error indication continues for 10 seconds. Unlit when the unit reverts to normal.
Controller side communication error code (Table 7.1-2)				(*2)	

(*1) PLC Side Communication Error Code

(Table 7.1-1)

Communication error code	Contents
i	Parity error
4	Sum error
$\bar{5}$	No response

$\bar{2}$, $\bar{3}$, $\bar{6}$: Reserved

(*2) Controller Side Communication Error Code

(Table 7.1-2)

Communication error code	Contents
i	Parity error
$\bar{2}$	Negative acknowledgement
4	Sum error
$\bar{5}$	No response

$\bar{3}$, $\bar{6}$: Reserved

7.2 Flexible Address Method

In this method, data exchange occurs under the conditions set via the console software as follows.

RO (Read Only) data items: The SIF-600 reads from the digital indicating controller, and writes to the PLC register.

RW (Read/Write) data items: If the Set value change flag is set, the SIF-600 sends the setting/reading command to the corresponding controller (of relevant data item and instrument number).

7.2.1 How to Read/Write Data on the PLC

PLC register section will be explained using (Table 7.2.1-1) and (Table 7.2.1-2) as examples.

(Table 7.2.1-1) System Section

PLC Address	Contents
200	PLC communication status, Controller communication status
201	Update counter
202	Set value change flag

(Table 7.2.1-2) Data Section

Data No.	PLC address	RO/RW	High order: Instrument number (*1) Low order: Sub address	Data item (*2)	Flag number
1	500	RW	00H/00H	0001H	2
2	501	RW	01H/00H	0001H	2
3	502	RW	02H/00H	0001H	2
4	505	RO	00H/00H	0080H	0
5	506	RO	01H/00H	0080H	0
6	507	RO	02H/00H	0080H	0

(*1) The setting range changes depending on the communication protocol.

- For Shinko protocol, set an instrument number within a range of 0 to 95, avoiding duplication.
- For Modbus protocol, set an instrument number within a range of 1 to 95, avoiding duplication.

(*2) Data item 0001H: SV setting

Data item 0080H: PV reading

(1) How to Read PV on the PLC

Data section of the controller PV is shown in (Table 7.2.1-3).

(Table 7.2.1-3)

Data No.	PLC address	Contents
4	505	PV of the controller numbered 0
5	506	PV of the controller numbered 1
6	507	PV of the controller numbered 2

The SIF-600 constantly reads PV from the digital indicating controller, and writes it to the PLC register addresses (505, 506, 507).

Read each value from the PLC register addresses.

Data flow of the PV reading is shown in (Fig. 7.2.1-1).

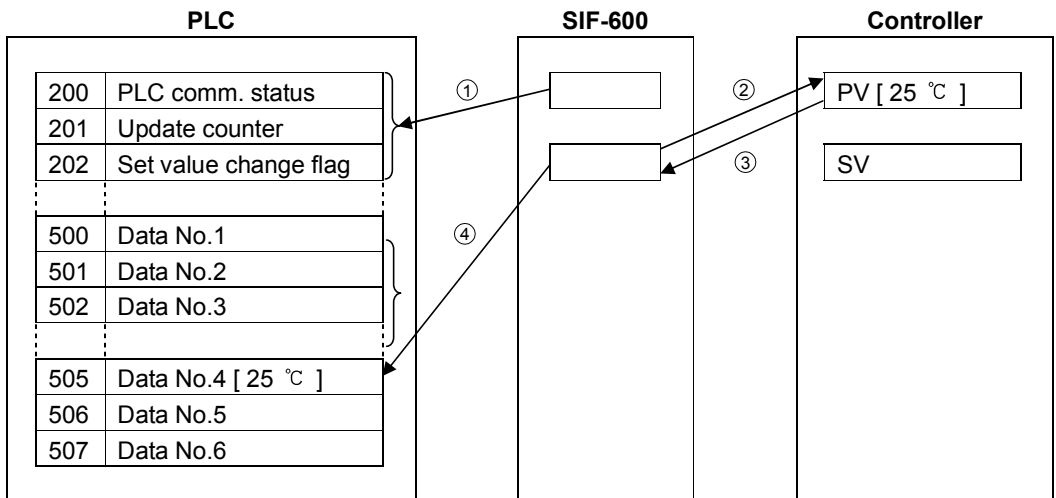

(Fig. 7.2.1-1)

- ① The SIF-600 checks the system data.
The SIF-600 checks PLC communication status and the Set value change flag, and writes a number by adding "1" to the Update counter.
- ② The SIF-600 sends the PV reading command to the controller numbered 0.
- ③ The SIF-600 receives the PV from the controller numbered 0.
- ④ The SIF-600 writes the PV to the PLC register address (505).
- ⑤ The SIF-600 repeats Steps ② to ④ for controllers numbered 1 and 2.
- ⑥ The SIF-600 repeats from Step ①.

(2) How to Write SV on the PLC

Data section of the controller SV is shown in (Table 7.2.1-4).

(Table 7.2.1-4)

Data No.	PLC register	Contents
1	500	SV of the controller numbered 0
2	501	SV of the controller numbered 1
3	502	SV of the controller numbered 2

The following example shows the controller numbered 0, when changing its SV to 100 °C.

- ① Write 100 °C to the PLC register address (500) corresponding to SV of the controller numbered 0.
- ② Write "2" to the Set value change flag (202).
- ③ Check that the Set value change flag (202) is cleared to 0 (zero).

Setting change is now complete.

Attention !

After the set value is changed, check the PLC communication status (200), and see if there is any error in the setting contents.

If errors have occurred, correct the data and resend it.

Data flow of the SV writing is shown in (Fig. 7.2.1-2).

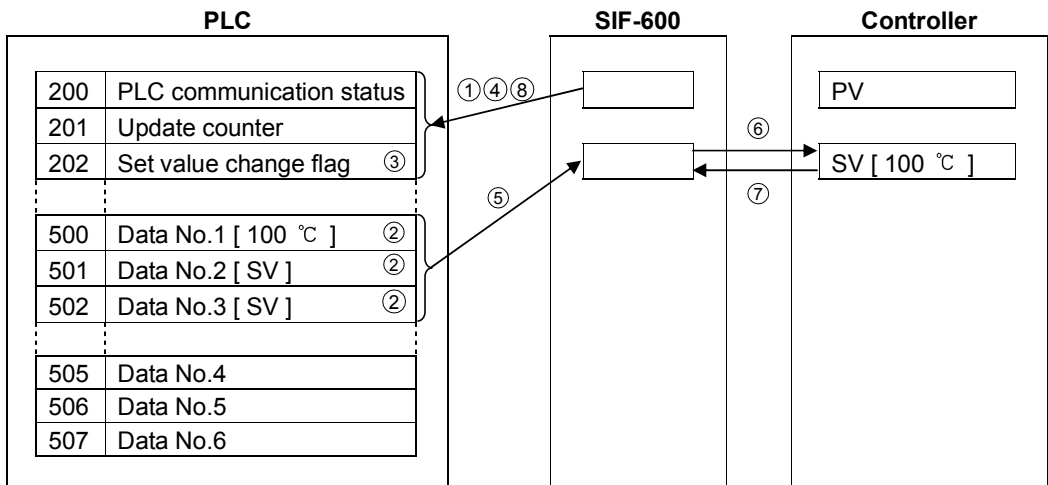

(Fig. 7.2.1-2)

- ① The SIF-600 checks the System data.
The SIF-600 checks PLC communication status and the Set value change flag, and writes a number by adding "1" to the Update counter.
- ② On the PLC side, write 100 °C to the PLC register address (500).
- ③ On the PLC side, write "2" to the Set value change flag.
- ④ The SIF-600 checks system data.
The SIF-600 checks that the Set value change flag is set to any value except 0 (zero).
- ⑤ The SIF-600 reads data from PLC register addresses (500 to 502).
- ⑥ The SIF-600 sends SV setting command to controllers numbered 0, 1 and 2.
- ⑦ The SIF-600 receives response from controllers numbered 0, 1 and 2.
- ⑧ The SIF-600 checks system data, and clears the Set value change flag to 0 (zero).

7.2.2 Action Details and Notes

[Countermeasure when the register data has been cleared]

If register data has been cleared, write "1" to the Set value change flag.

If "1" is written to the Set value change flag, the SIF-600 will read all setting item data from the controller, and write it to the PLC register section.

[AT (Auto-tuning)]

When AT is performed, write "1" to the Set value change flag to update all values (proportional band, integral time, derivative time, ARW) attained from the controller after AT is complete.

If "1" is written to the Set value change flag, the SIF-600 will read all setting item data from the controller, and write it to the PLC register section.

[Alarm type]

If alarm type of the controller is changed, the alarm value of the controller will automatically return to 0 (zero).

Therefore, be sure to set the alarm value again from the PLC after alarm type is changed.

[Set value change flag]

When setting the Set value change flag, check that it is 0 (zero), then set it to a value.

If the Set value change flag is set to a value while the value is anything other than 0 (zero), setting change may not occur normally.

If "1" is written to the Set value change flag, the SIF-600 will read all setting item data from the controller, and write it to the PLC register section.

[Setting Range of Set Value]

The SIF-600 does not manage the setting range of each setting item of controllers.

When setting any values from the PLC, be sure to set them within the setting range.

7.3 Multi Address Method

In this method, data exchange occurs as follows under the conditions set on the console software. Block communication command (multiple data communication command in Modbus protocol) is available.

This method can be used for Shinko Multi-point temperature control system C series or Temperature control boards.

RO (Read Only) data items: The SIF-600 reads from the digital indicating controller, then writes to the PLC register.

RW (Read/Write) data items: If the Set value change flag is set, the SIF-600 sends the setting/reading command to the corresponding controller (of relevant data item and instrument number).

7.3.1 How to Read/Write Data on the PLC

PLC register section will be explained using (Table 7.3.1-1) and (Table 7.3.1-2) as examples.

(Table 7.3.1-1) System Section

PLC address	Contents
200	PLC communication status, Controller communication status
201	Update counter
202	Set value change flag

(Table 7.3.1-2) Data Section

Data No.	PLC address	RO/RW	High-order: Instrument number (*1) Low-order: Sub address	Data item (*2)	Flag number	PLC data amount
1	1000	RW	00H/00H	0001H	2	3
2						
3						
4	1003	RW	01H/00H	0001H	2	3
5						
6						
7	2000	RO	00H/00H	0080H	0	3
8						
9						
10	2003	RO	01H/00H	0080H	0	3
11						
12						

(*1) The setting range changes depending on the communication protocol.

- For Shinko protocol, set an instrument number within a range of 0 to 95, avoiding duplication.
- For Modbus protocol, set an instrument number within a range of 1 to 95, avoiding duplication.

(*2) Data item 0001H: SV setting

Data item 0080H: PV reading

(1) How to Read PV on the PLC

Data section of the controller PV is shown in (Table 7.3.1-3).

(Table 7.3.1-3)

Data No.	PLC address	Contents
7	2000	Digital indicating controller numbered 0 CH1 PV
8	2001	Digital indicating controller numbered 0 CH2 PV
9	2002	Digital indicating controller numbered 0 CH3 PV
10	2003	Digital indicating controller numbered 1 CH1 PV
11	2004	Digital indicating controller numbered 1 CH2 PV
12	2005	Digital indicating controller numbered 1 CH3 PV

The SIF-600 constantly reads PV from the controllers, and writes it to the PLC register addresses (2000 to 2005).

Read each value from PLC register addresses.

Data Flow of the PV Reading is shown below. (Fig. 7.3.1-1)

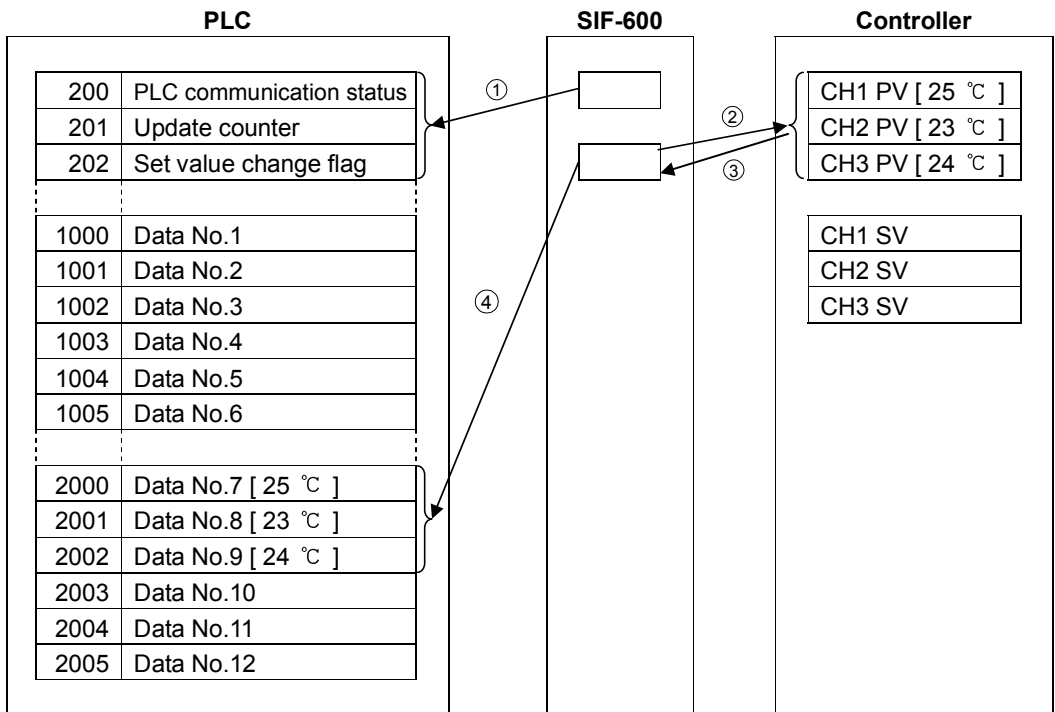

(Fig. 7.3.1-1)

- ① The SIF-600 checks the System data.
The SIF-600 checks PLC communication status and the Set value change flag, and writes a number by adding "1" to the Update counter.
- ② The SIF-600 sends PV reading command to the controller numbered 0.
- ③ The SIF-600 receives PV from the controller numbered 0.
- ④ The SIF-600 writes PV to the PLC register addresses (2000, 2001, 2002).
- ⑤ The SIF-600 repeats Steps ② to ④ for the controller numbered 1.
- ⑥ The SIF-600 repeats from ①.

(2) How to Write SV on the PLC

Data section of the controller SV is shown in (Table 7.3.1-4).

(Table 7.3.1-4)

Data No.	PLC address	Contents
1	1000	Digital indicating controller numbered 0 CH1 SV
2	1001	Digital indicating controller numbered 0 CH2 SV
3	1002	Digital indicating controller numbered 0 CH3 SV
4	1003	Digital indicating controller numbered 1 CH1 SV
5	1004	Digital indicating controller numbered 1 CH2 SV
6	1005	Digital indicating controller numbered 1 CH3 SV

The following example shows the controller numbered 0, when changing its SV to 100 °C.

- ① Write 100 °C to the PLC register addresses (1000 to 1002) corresponding to SV of controller numbered 0.
- ② Write "2" to the Set value change flag (202).
- ③ Check that Set value change flag (202) is cleared to 0 (zero).

Setting change is now complete.

Attention !

After the set value is changed, check the PLC communication status (200), and see if there is any error in the setting contents.

If errors have occurred, correct the data and resend it.

Data Flow of the SV Writing is shown in (Fig. 7.3.1-2).

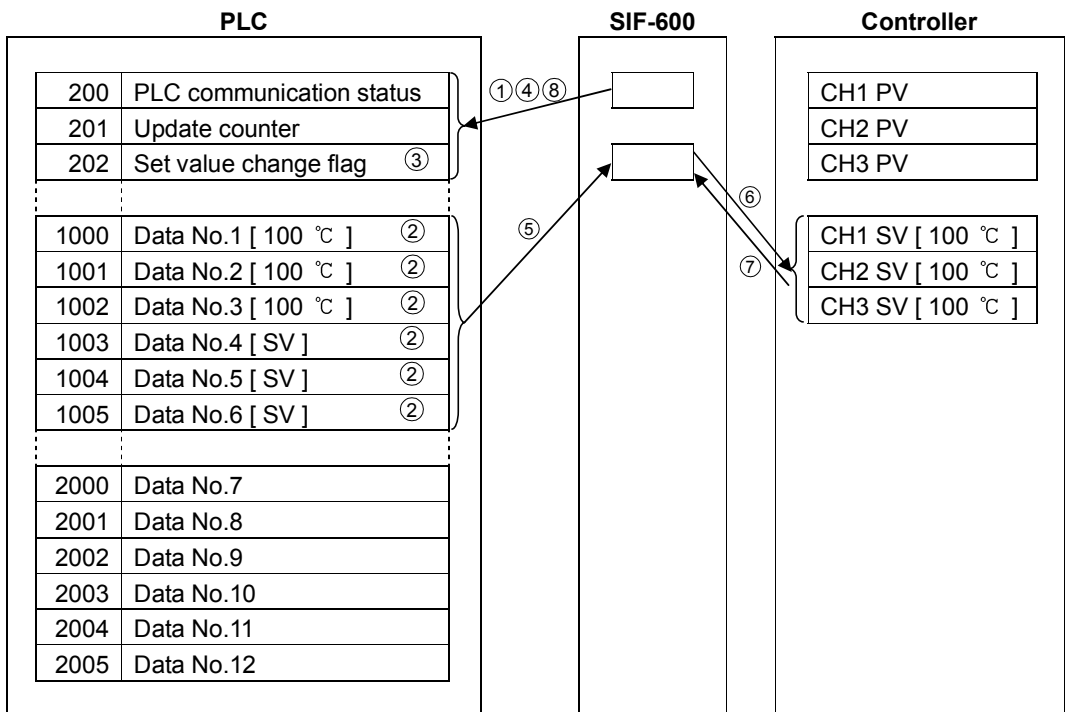

(Fig. 7.3.1-2)

- ① The SIF-600 checks the System data.
The SIF-600 checks PLC communication status and the Set value change flag, and writes a number by adding “1” to the Update counter.
- ② On the PLC side, write 100 °C to the PLC register addresses (1000 to 1002).
- ③ On the PLC side, write “2” to the Set value change flag.
- ④ The SIF-600 checks system data.
Check that the Set value change flag is set to any value except 0 (zero).
- ⑤ The SIF-600 reads data from the PLC register addresses (1000 to 1005).
- ⑥ The SIF-600 sends SV setting command to controllers numbered 0 and 1.
- ⑦ The SIF-600 receives response from controllers numbered 0 and 1.
- ⑧ The SIF-600 checks system data, and clears the Set value change flag to 0.

7.3.2 Action Details and Notes

[Countermeasure when the register data has been cleared]

If register data has been cleared, write “1” to the Set value change flag.

If “1” is written to the Set value change flag, the SIF-600 will read all setting item data from the controllers, and write it to the PLC register section.

[AT (Auto-tuning)]

When AT is performed, write “1” to the Set value change flag to update all values (proportional band, integral time, derivative time, ARW) attained from the controller after AT is complete.

If “1” is written to the Set value change flag, the SIF-600 will read all setting item data from the controllers, and write it to the PLC register section.

[Alarm type]

If the alarm type of the controller is changed, automatically the alarm value of the controller returns to 0 (zero).

Therefore, be sure to set the alarm value again from the PLC after alarm type is changed.

[Set value change flag]

When setting the Set value change flag, check that it is 0 (zero), then set it to a value.

If the Set value change flag is set to a value while the value is anything other than 0 (zero), setting change may not occur normally.

If “1” is written to the Set value change flag, the SIF-600 reads all setting item data from the controllers, and writes it to the PLC register section.

[Setting Range of Set Value]

The SIF-600 does not manage the setting range of each setting item of controllers.

When setting any values from the PLC, be sure to set values within the setting range.

7.4 Flagless Method

In this method, data exchange occurs as follows under the conditions set via the console software. The Set value change flag is not used.

RO (Read Only) data items: The SIF-600 constantly reads from the digital indicating controller, then writes them to the PLC register.

RW (Read/Write) data items: The SIF-600 reads data from the controller and corresponding data from the PLC register alternately, and if any change is found, the SIF-600 writes the change to the other side (controller or PLC).

7.4.1 How to Read/Write Data on the PLC

PLC register section will be explained using (Table 7.4.1-1), (Table 7.4.1-2) and (Table 7.4.1-3) as examples.

(Table 7.4.1-1) System Section

PLC address	Contents
200	PLC communication status, Controller communication status
201	Update counter
202	Communication item change flag

(Table 7.4.1-2) Data Section

Data No.	PLC address	RO/RW	PLC address for saving controller's instrument number	PLC address for saving controller's data item
1	1000	RW	1500	2000
2	1001	RW	1501	2001
3	1002	RW	1502	2002
4	1003	RO	1503	2003
5	1004	RO	1504	2004
6	1005	RO	1505	2005

(Table 7.4.1-3) Data Section and PLC Register Details

PLC address	Data	Contents
1500	0000H	Data No.1 instrument number and sub address (*1) High-order: Instrument number Low-order: Sub address
1501	0100H	Data No.2 instrument number and sub address (*1) High-order: Instrument number Low-order: Sub address
1502	0200H	Data No.3 instrument number and sub address (*1) High-order: Instrument number Low-order: Sub address
1503	0000H	Data No.4 instrument number and sub address (*1) High-order: Instrument number Low-order: Sub address
1504	0100H	Data No.5 instrument number and sub address (*1) High-order: Instrument number Low-order: Sub address
1505	0200H	Data No.6 instrument number and sub address (*1) High-order: Instrument number Low-order: Sub address
⋮	⋮	⋮
2000	0001H	Data No.1 Data item (*2)
2001	0001H	Data No.2 Data item (*2)
2002	0001H	Data No.3 Data item (*2)
2003	0080H	Data No.4 Data item (*2)
2004	0080H	Data No.5 Data item (*2)
2005	0080H	Data No.6 Data item (*2)

(*1) The setting range changes depending on the communication protocol.

- For Shinko protocol, set an instrument number within a range of 0 to 95, avoiding duplication.
- For Modbus protocol, set an instrument number within a range of 1 to 95, avoiding duplication.

(*2) Data item 0001H: SV setting

Data item 0080H: PV reading

(1) How to Read PV on the PLC

Data section of the controller PV is shown in (Table 7.4.1-4).

(Table 7.4.1-4)

Data No.	PLC address	Contents
4	1003	Digital indicating controller numbered 0 PV
5	1004	Digital indicating controller numbered 1 PV
6	1005	Digital indicating controller numbered 2 PV

The SIF-600 constantly reads PV of controllers, and writes them to the PLC register addresses (1003, 1004, 1005).

Read each value from PLC register addresses.

Data flow of the PV reading is shown in (Fig. 7.4.1-1).

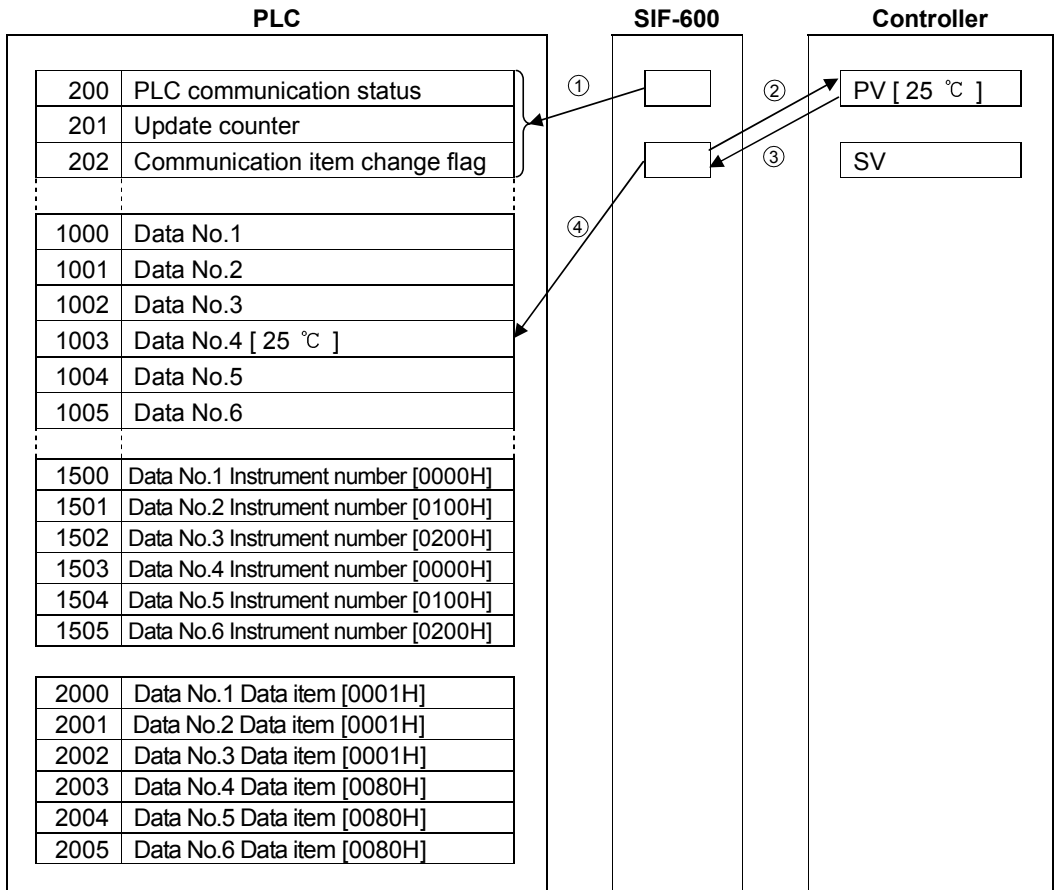

(Fig. 7.4.1-1)

- ① The SIF-600 checks the system data.
The SIF-600 checks PLC communication status and Communication item change flag, and writes a number by adding "1" to the Update counter.
- ② The SIF-600 sends the PV reading command to the controller numbered 0, which corresponds to Data No. 4 (*). (*): PLC register addresses (1003, 1503, 2003)
- ③ The SIF-600 receives the PV from the controller numbered 0.
- ④ The SIF-600 writes the PV to the PLC register address (1003).
- ⑤ The SIF-600 repeats Steps ② to ④ for the controllers numbered 1 and 2.
- ⑥ The SIF-600 repeats from Step ①.

(2) How to Update SV on the PLC or Controller

Data section of the controller SV is shown in (Table 7.4.1-5).

(Table 7.4.1-5)

Data No.	PLC address	Contents
1	1000	Digital indicating controller numbered 0 SV
2	1001	Digital indicating controller numbered 1 SV
3	1002	Digital indicating controller numbered 2 SV

The SIF-600 reads data from both the controller and corresponding PLC register alternately, and compares their values with the internal data of the SIF-600. If any change is found, the SIF-600 writes the change to the other side (controller or PLC).

Usual data flow (when there is no change in SV) is shown in (Fig. 7.4.1-2).

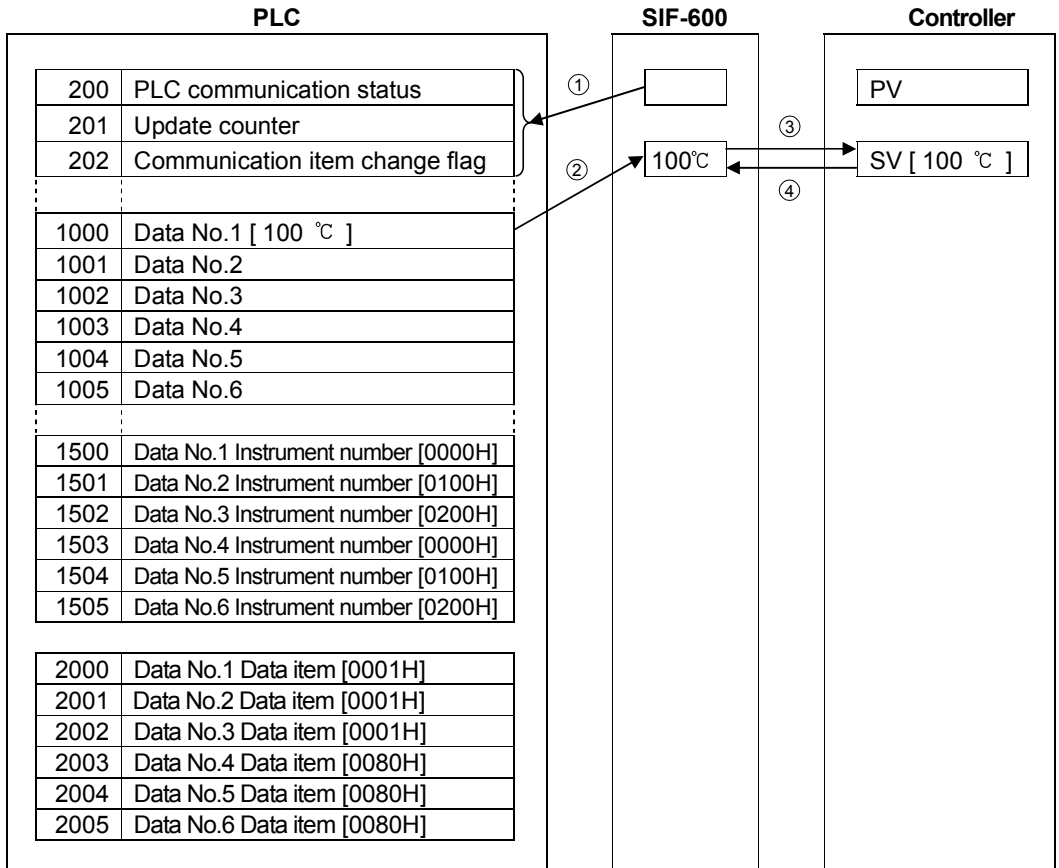

(Fig. 7.4.1-2)

- ① The SIF-600 checks the system data.
The SIF-600 checks PLC communication status and Communication item change flag, and writes a number by adding "1" to the Update counter.
- ② The SIF-600 reads data from the PLC register address (1000: Data No.1).
The SIF-600 compares the SV (100 °C) of the PLC register and its own internal value (100 °C), and if there is no change, the SIF-600 does not process anything.
- ③ The SIF-600 sends the SV reading command to the controller numbered 0, corresponding to Data No.1 (*). (* PLC register addresses (1000, 1500, 2000))
- ④ The SIF-600 receives SV from the controller numbered 0. The SIF-600 compares the received SV (100 °C) and its own internal value (100 °C), and if there is no change, the SIF-600 does not process anything.
- ⑤ The SIF-600 repeats Steps ② to ④ for the controllers numbered 1 and 2.
- ⑥ The SIF-600 repeats from Step ①.

Data flow when Data No.1 data is changed from 100℃ to 200℃ on the PLC side is shown in (Fig. 7.4.1-3).

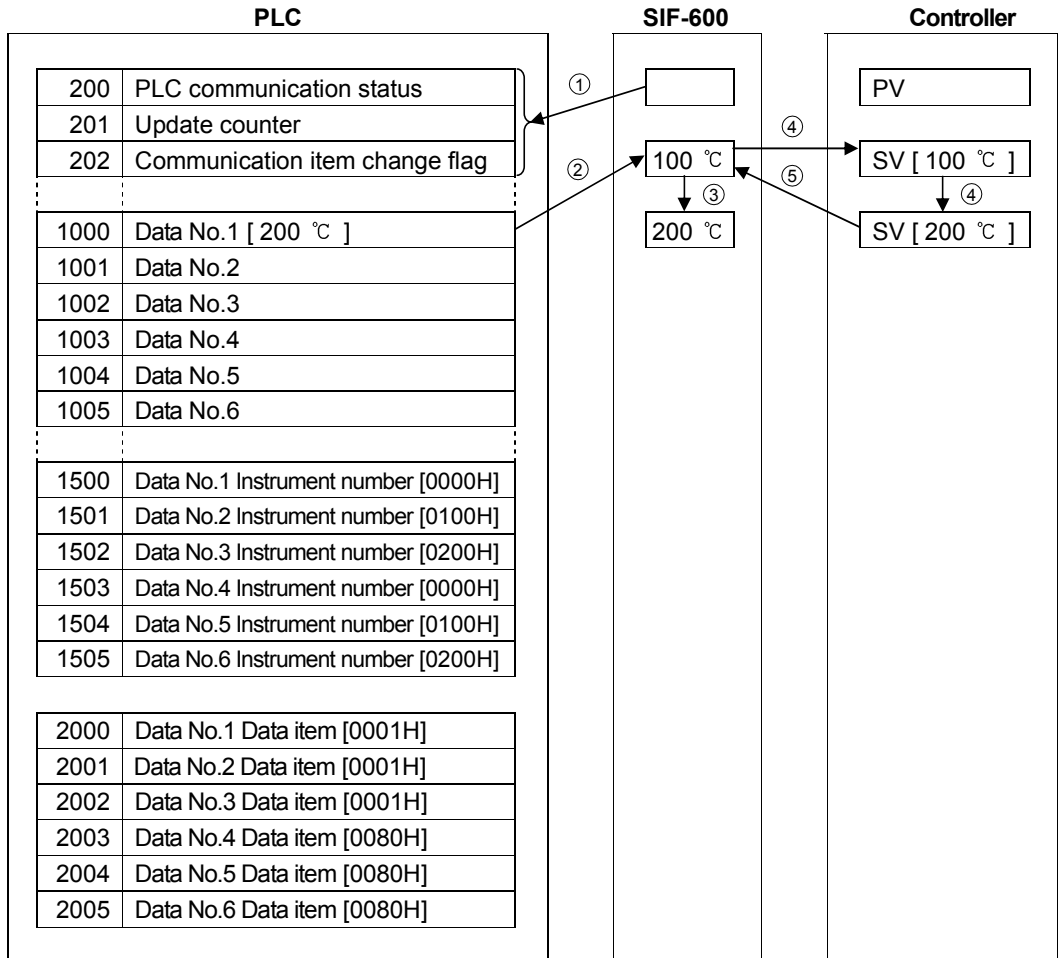

(Fig. 7.4.1-3)

- ① The SIF-600 checks the System data.
The SIF-600 checks PLC communication status and Communication item change flag, and writes a number by adding "1" to the Update counter.
- ② The SIF-600 reads data from the PLC register address (1000: Data No.1). The SIF-600 compares the SV (200 ℃) of the PLC register and its own internal value (100 ℃), and confirms that there is a change.
- ③ The SIF-600 updates the internal value to 200 ℃.
- ④ The SIF-600 sends SV setting command (updated data 200℃) to the controller numbered 0, corresponding to Data No.1 (*). (* PLC register addresses (1000, 1500, 2000))
- ⑤ The SIF-600 receives response from the controller numbered 0.
- ⑥ The data flow carried out is the same as the Usual data flow (when there is no change in SV) on p.86.

When SV is changed from 100 °C to 200 °C on the controller numbered 0, the data flow is shown in (Fig. 7.4.1-4).

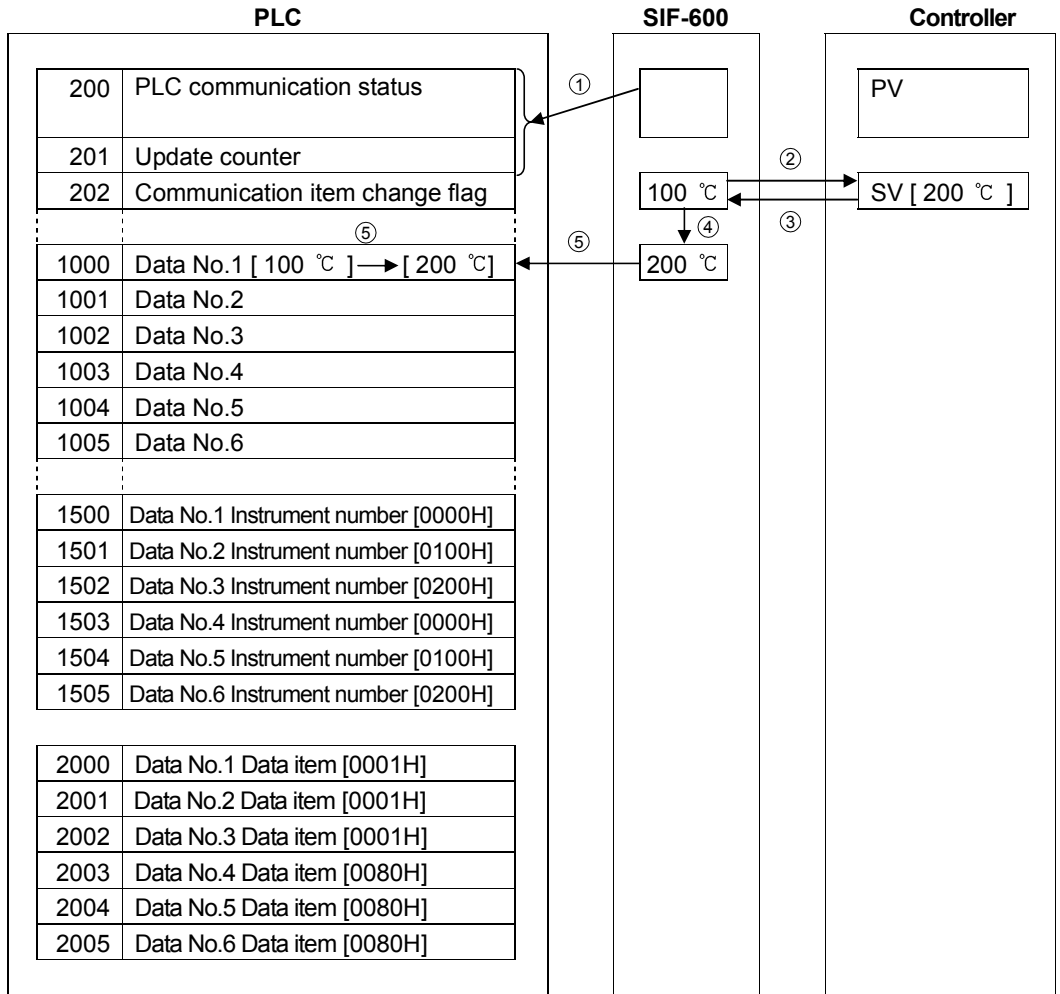

(Fig. 7.4.1-4)

- ① The SIF-600 checks the system data.
The SIF-600 checks PLC communication status and Communication item change flag, and writes a number by adding "1" to the Update counter.
- ② The SIF-600 sends the SV reading command to the controller numbered 0, corresponding to Data No.1 (*). (*) PLC register addresses (1000, 1500, 2000)
- ③ The SIF-600 receives the SV from the controller numbered 0.
The SIF-600 compares the received SV (200 °C) and its own internal value (100 °C), and confirms that there is a change in SV.
- ④ The SIF-600 updates the internal value to 200 °C.
- ⑤ The SIF-600 writes the updated data (200 °C) to the PLC register address (1000: Data No.1).
- ⑥ The data flow carried out is the same as the Usual data flow (when there is no change in SV) on p.86.

(3) Communication Item Change Flag

This flag is used to change the instrument number and data item of Data No. to which RW (Read/Write) is specified.

Data flow when Data No.1 instrument number is changed from 0 to 3 is shown in (Fig. 7.4.1-5).

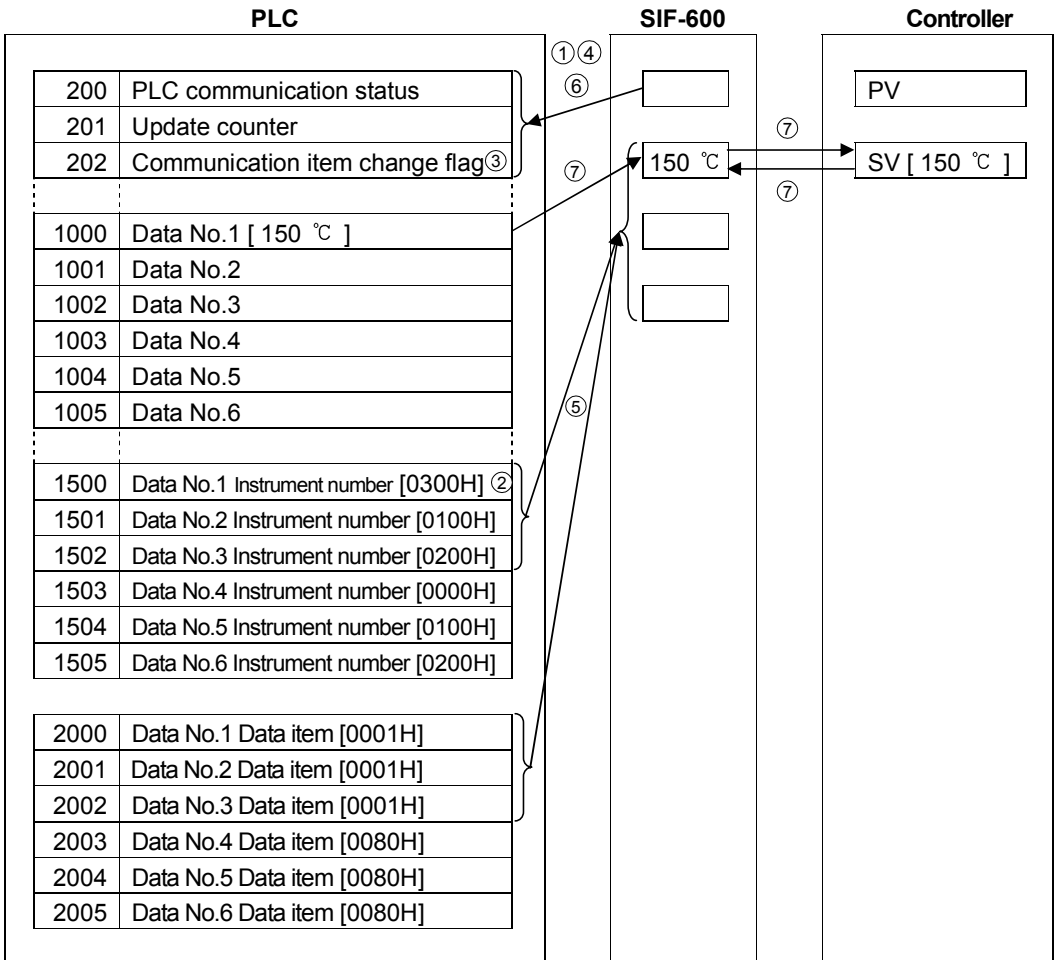

(Fig. 7.4.1-5)

- ① The SIF-600 checks the system data.
The SIF-600 checks PLC communication status and Communication item change flag, and writes a number by adding "1" to the Update counter.
- ② On the PLC side, write 0300H (Instrument number: 3, Sub address: 0) to the PLC register address (1500: Data No.1 instrument number).
- ③ On the PLC side, write "1" to the Communication item change flag.
- ④ The SIF-600 checks the system data, and confirms that Communication item change flag is set to "1".
- ⑤ The SIF-600 reads again the instrument number and data item of Data No. to which RW (Read/Write) is specified.
- ⑥ The SIF-600 clears the Communication item change flag to 0 (zero).
- ⑦ The SIF-600 exchanges data under the conditions (Instrument number: 3, Sub address: 0, Data item: SV), corresponding to Data No.1 (*).
(*) PLC register addresses (1000, 1500, 2000)
- ⑧ The data flow carried out is the same as the Usual data flow (when there is no change in SV) on p.86.

Data flow when Data No.1 data item is changed from SV to Alarm 1 value is shown in (Fig. 7.4.1-6).

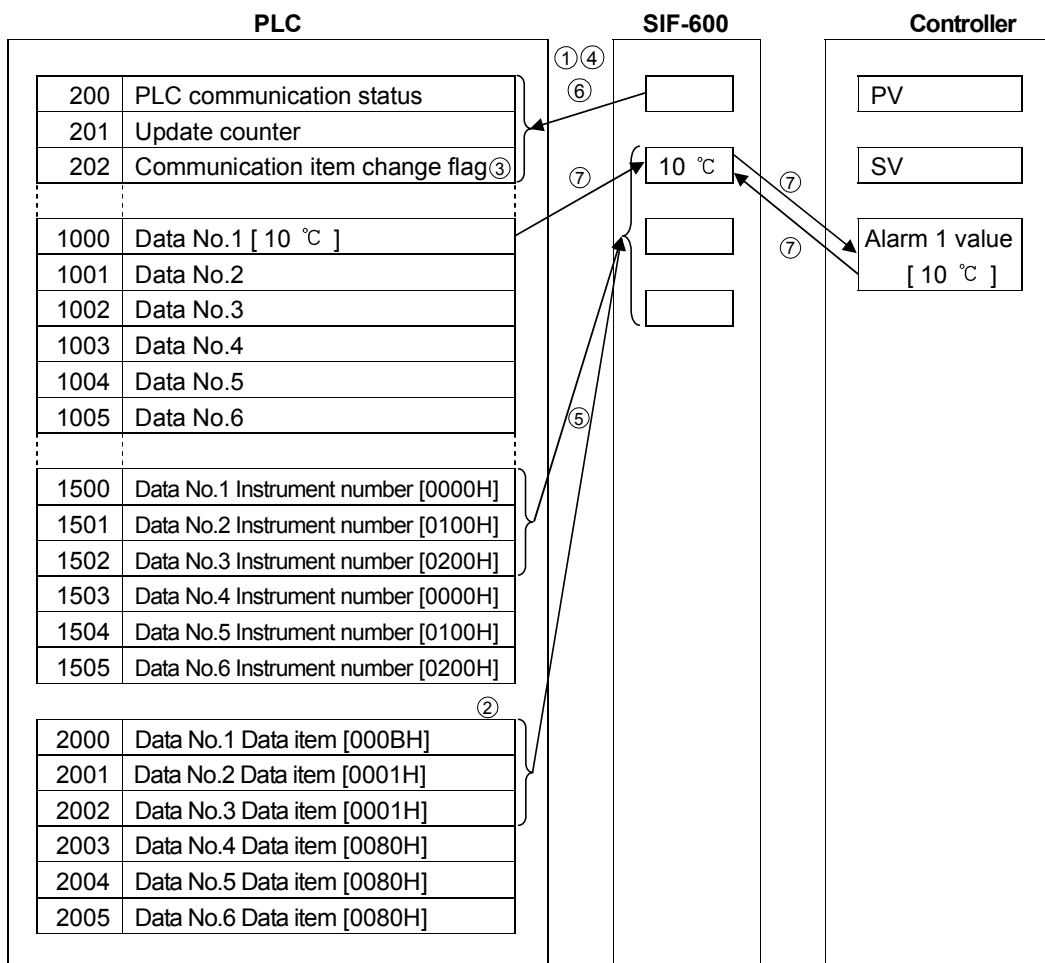

(Fig. 7.4.1-6)

- ① The SIF-600 checks the system data.
The SIF-600 checks PLC communication status and the Communication item change flag, and writes a number by adding "1" to the Update counter.
- ② On the PLC side, write 000BH (Alarm 1 value) to the PLC register address (2000: Data No.1 data item).
- ③ On the PLC side, write "1" to the Communication item change flag.
- ④ The SIF-600 checks the system data.
The SIF-600 checks that the Communication item change flag is set to "1".
- ⑤ The SIF-600 reads again the instrument number and data item of Data No. to which RW (Read/Write) is specified.
- ⑥ The SIF-600 clears the Communication item change flag to 0 (zero).
- ⑦ The SIF-600 exchanges data under the conditions (Instrument number: 0, Sub address: 0, Data item: Alarm 1 value), corresponding to Data No.1 (*).
(*) PLC register addresses (1000, 1500, 2000)
- ⑧ The data flow carried out is the same as the Usual data flow (when there is no change in SV) on p.86.

7.4.2 Action Details and Notes

[AT (Auto-tuning)]

When AT is performed, the PLC data memory (proportional band, integral time, derivative time, ARW) is updated, using each value (proportional band, integral time, derivative time, ARW) attained from the controller after AT is complete.

[Alarm type]

If the alarm type of the controller is changed, the alarm value of the controller will automatically return to 0 (zero).

After the alarm type is changed, be sure to set the alarm value from the PLC again.

[Setting range of set value]

The SIF-600 does not manage the setting range of each setting item of controllers.

When setting any values from the PLC, be sure to set them within the setting range.

[Data update when power supply to the whole system is turned from OFF to ON]

When power supply to the whole system is turned from OFF to ON, the SIF-600 automatically reads data from the digital temperature controllers, and writes it to the PLC register.

7.5 Fixed Address Method

In this method, data exchange occurs under the conditions set on the console software as follows.

A maximum of 20 controllers can be connected.

20-Words per data item are occupied in the PLC register section. (The same applies even when less than 20 controllers are connected.)

RO (Read Only) data items: The SIF-600 constantly reads from the digital indicating controller, and writes to the PLC register.

RW (Read/Write) data items: If the Set value change flag is set, the SIF sends the setting/reading command for the predetermined data items to all connected controllers.

7.5.1 How to Read/Write Data on the PLC

PLC register section will be explained using (Table 7.5.1-1) and (Table 7.5.1-2) as examples. (3 units of controller are connected.)

(Table 7.5.1-1) System Section

PLC address	Contents
500	PLC communication status, Controller communication status
501	Update counter
502	Set value change flag

(Table 7.5.1-2) Data Section

Data No.	PLC address	RO/RW	Data item		Data amount	Flag number (*3)
1	1000 to 1019	RW	0001	CH1 SV	20	Read: -2/Write: 2
2	1020 to 1039	RW	000B	CH1 Alarm 1 value	20	Read: -3/Write: 3
3	1040 to 1059	RW	0002	CH1 AT/Auto-reset Perform/Cancel	20	Read: -4/Write: 4
4	1060 to 1079	RW	0028	CH1 Control Allowed/Prohibited	20	Read: -5/Write: 5
5	1080 to 1099	RW	0051	CH2 SV	20	Read: -6/Write: 6
6	1100 to 1119	RW	0071	CH2 Alarm 1 value	20	Read: -7/Write: 7
7	1120 to 1139	RW	0052	CH2 AT/Auto-reset Perform/Cancel	20	Read: -8/Write: 8
8	1140 to 1159	RW	0078	CH2 Control Allowed/Prohibited	20	Read: -9/Write: 9
9	1160 to 1179	RO(*1)	0080	CH1 PV reading	20	Read: -10/Write: 10
10	1180 to 1199	RO(*1)	0083	CH1 Status flag reading	20	Read: -11/Write: 11
11	1200 to 1219	RO(*1)	0090	CH2 PV reading	20	Read: -12/Write: 12
12	1220 to 1239	RO(*1)	0093	CH2 Status flag reading	20	Read: -13/Write: 13
13	1240 to 1259	(*2)	(*2)		20	Read: -14/Write: 14
14	1260 to 1279	(*2)	(*2)		20	Read: -15/Write: 15

Data No.	PLC address	RO/RW	Data item		Data amount	Flag number (*3)
15	1280 to 1299	(*2)	(*2)		20	Read: -16/Write: 16
16	1300 to 1319	(*2)	(*2)		20	Read: -17/Write: 17
17	1320 to 1339	(*2)	(*2)		20	Read: -18/Write: 18
18	1340 to 1359	(*2)	(*2)		20	Read: -19/Write: 19
19	1360 to 1379	(*2)	(*2)		20	Read: -20/Write: 20
20	1380 to 1399	(*2)	(*2)		20	Read: -21/Write: 21
21	1400 to 1419	(*2)	(*2)		20	Read: -22/Write: 22
22	1420 to 1439	(*2)	(*2)		20	Read: -23/Write: 23
23	1440 to 1459	(*2)	(*2)		20	Read: -24/Write: 24
24	1460 to 1479	(*2)	(*2)		20	Read: -25/Write: 25
25	1480 to 1499	(*2)	(*2)		20	Read: -26/Write: 26

(*1) RO specified Data No. is Read Only item, and the Set value change flag is disabled.

(*2) Up to Data No. 25 will be occupied in the PLC register section even if some of them are not used. 20-Words are occupied per data item. (The same applies even when less than 20 units of controller are connected.)

(*3) On the PLC side, if "1" is written to the Set value change flag, the SIF-600 will read all setting items from the PLC register section, and send the setting command to the digital indicating controller.

On the PLC side, if "-1" is written to the Set value change flag, the SIF-600 reads all setting items from the controller, and writes them to the PLC register.

(1) How to Read PV on the PLC

Data section of the controller PV is shown in (Table 7.5.1-3).

(Table 7.5.1-3)

Data No.	PLC address	Contents
9	1160 to 1162	Digital indicating controllers numbered 0, 1 and 2 CH1 PV
11	1200 to 1202	Digital indicating controllers numbered 0, 1 and 2 CH2 PV

The SIF-600 constantly reads PV of the controller, and writes them to the PLC register addresses (1160 to 1162, 1200 to 1202).

Read each value from PLC register.

Data flow of CH1 PV reading is shown in (Fig. 7.5.1-1).

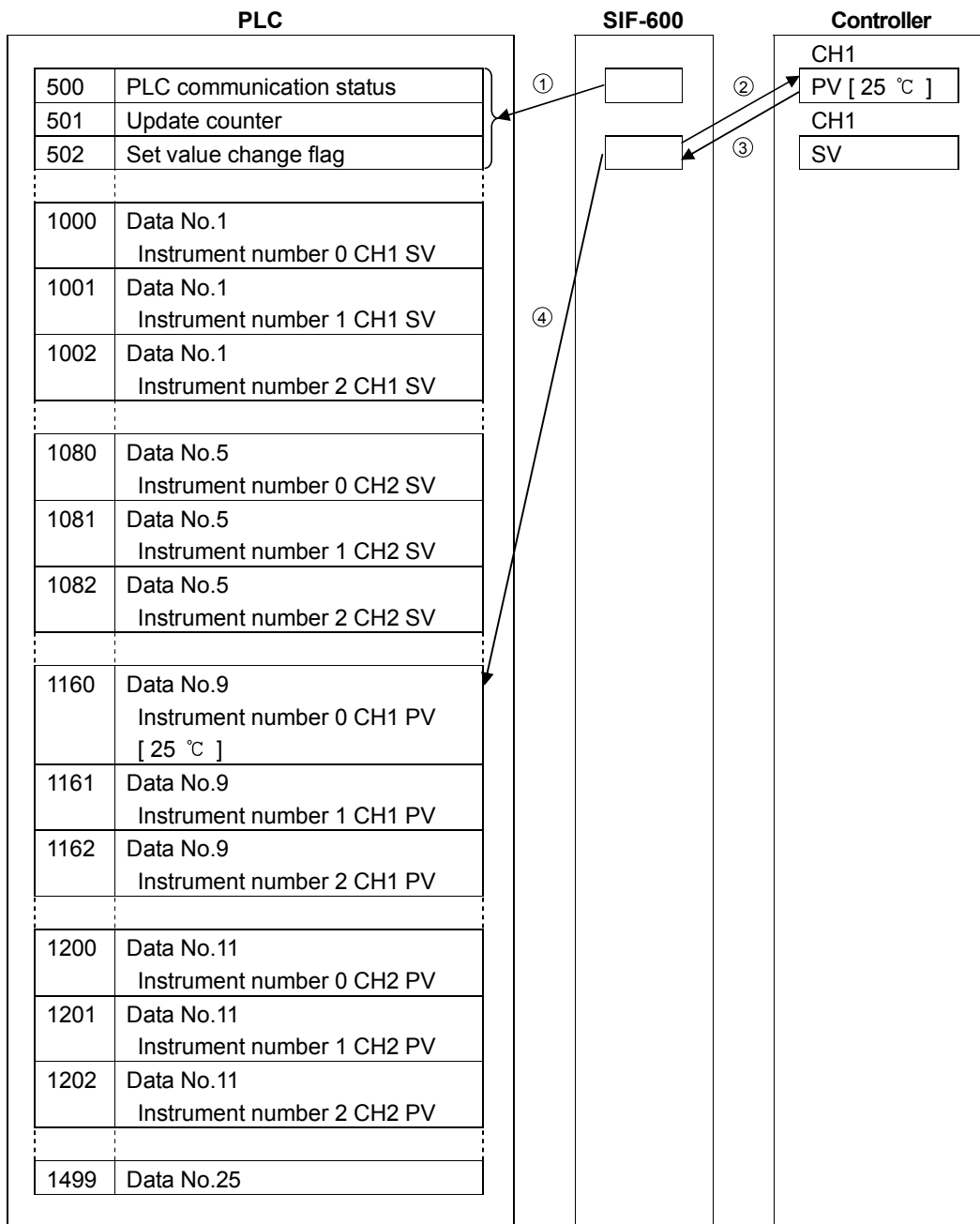

- ① The SIF-600 checks the System data.
The SIF-600 checks PLC communication status and the Set value change flag, and writes a number by adding "1" to the Update counter.
- ② The SIF-600 sends the CH1 PV reading command to the controller numbered 0.
- ③ The SIF-600 receives CH1 PV from the controller numbered 0.
- ④ The SIF-600 writes PV to the PLC register address (1160).
- ⑤ The SIF-600 repeats Steps ② to ④ for the controller numbered 1 and 2.
- ⑥ The SIF-600 repeats from ①.

(2) How to Write SV on the PLC

Data section of the controller SV is shown in (Table 7.5.1-4).

(Table 7.5.1-4)

Data No.	PLC address	Contents
1	1000 to 1002	Digital indicating controller numbered 0, 1, 2 CH1 SV
2	1080 to 1082	Digital indicating controller numbered 0, 1, 2 CH2 SV

The following example shows the controller numbered 0, when changing its CH1 SV to 100 °C.
(Only the controller numbered 0 is changed.)

- ① Write 100 °C to the PLC register address (1000) corresponding to CH1 SV of the controller numbered 0.
- ② Write "2" to the Set value change flag (502).
- ③ Check that the Set value change flag (502) is cleared to 0 (zero).

Setting changes are now complete.

Attention !

After the set value is changed, check the PLC communication status (500), and see if there is any error in the setting contents.

If errors have occurred, correct the data and resend it.

Data flow of CH1 SV writing is shown in (Fig. 7.5.1-2).

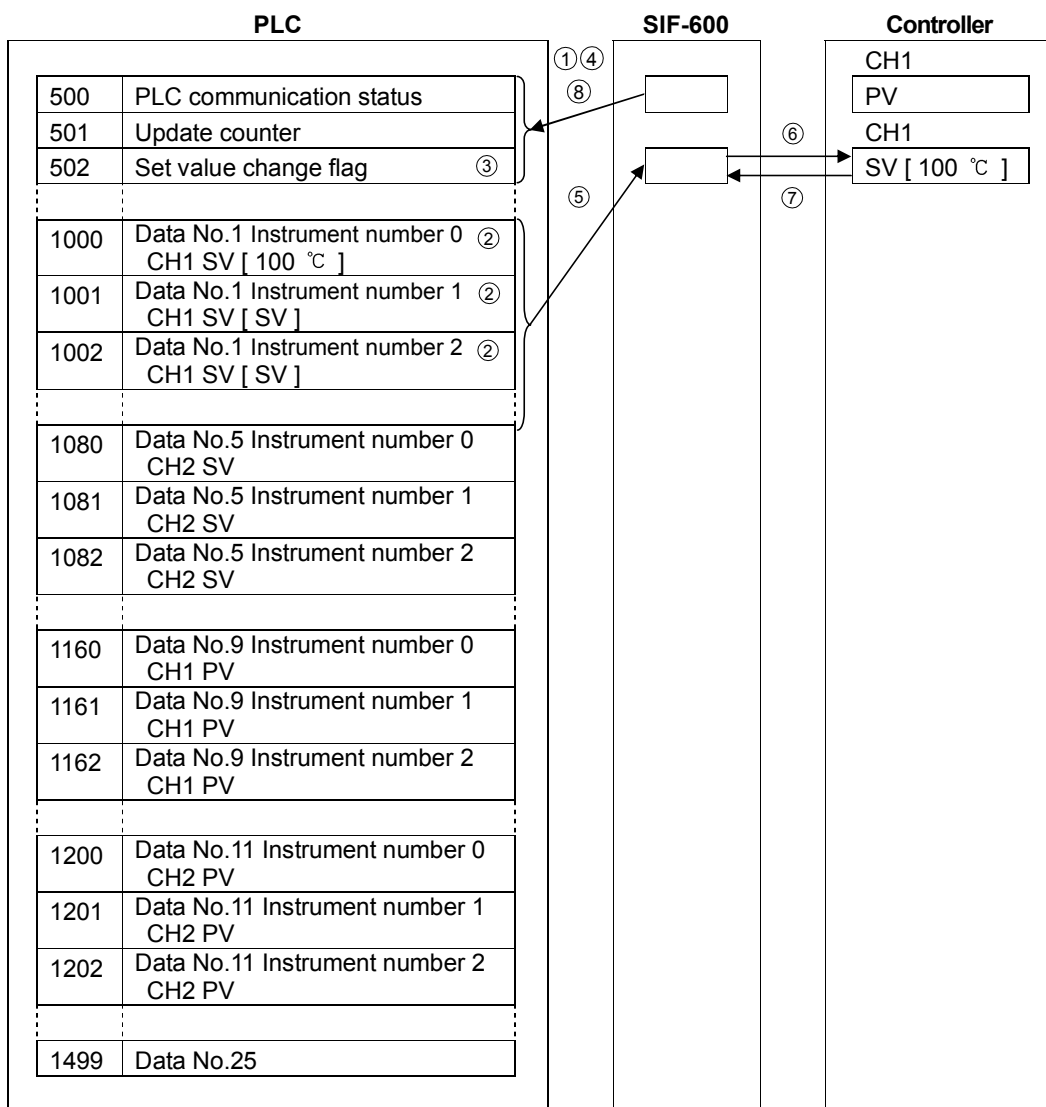

(Fig. 7.5.1-2)

- ① The SIF-600 checks the System data.
The SIF-600 checks PLC communication status and the Set value change flag, and writes a number by adding "1" to the Update counter.
- ② On the PLC side, write 100 °C to the PLC register address (1000).
- ③ On the PLC side, write "2" to the Set value change flag.
- ④ The SIF-600 checks system data.
The SIF-600 checks that the Set value change flag is set to any value except 0 (zero).
- ⑤ The SIF-600 reads data from PLC register addresses (1000 to 1002).
- ⑥ The SIF-600 sends CH1 SV setting command to the controllers numbered 0, 1 and 2.
- ⑦ The SIF-600 receives response from the controllers numbered 0, 1 and 2.
- ⑧ The SIF-600 checks system data, and clears the Set value change flag to 0 (zero).

7.5.2 Action Details and Notes

[Countermeasure when the register data has been cleared]

If register data has been cleared, write “-1” to the Set value change flag.

If “-1” is written to the Set value change flag, the SIF-600 will read all setting item data from the controller, and write it to the PLC register section.

With the Flexible address and Multi address methods, the Set value change flag 1 (positive number) operates the SIF-600 to read all setting item data from the controller, and to write to the PLC register section.

Take note that the Set value change flag is a negative number only for the Fixed address method.

[AT (Auto-tuning)]

When AT is performed, write “-1” to the Set value change flag to update all values (proportional band, integral time, derivative time, ARW) attained from the controller after AT is complete.

If “-1” is written to the Set value change flag, the SIF-600 will read all setting item data from the controller, and write it to the PLC register section.

[Alarm type]

If the alarm type of the controller is changed, the alarm value of the controller will automatically return to 0 (zero).

Therefore, be sure to set the alarm value again from the PLC after alarm type is changed.

[Set value change flag]

When setting the Set value change flag, check that it is 0 (zero), then set the flag to any value.

If the Set value change flag is set to a value while the value is anything other than 0 (zero), setting change may not occur normally.

On the PLC side, if “1” is written to the Set value change flag, the SIF-600 will read all setting items from the PLC register section, and send the setting command to the controller.

On the PLC side, if “-1” is written to the Set value change flag, the SIF-600 will read all setting items from the controller, and write them to the PLC register section.

[Setting range of set value]

The SIF-600 does not manage the setting range of each setting item of controllers.

When setting any values from the PLC, be sure to set them within the setting range.

8. Specifications

Rating

Supply voltage	100 to 240 V AC 50/60 Hz or 24 V AC/DC 50/60 Hz Allowable fluctuation range: 100 to 240 V AC 50/60 Hz: 85 to 264 V AC 24 V AC/DC 50/60 Hz: 20 to 28 V AC/DC
Communication line	
Between SIF and PLC	RS-232C, RS-485, RS-422A (terminals)
Between SIF and controller	RS-485 (modular jack, terminals)

General Structure

External dimensions	30 x 88 x 108 mm (W x H x D, including socket)
Mounting	DIN rail
Case	Flame-resistant Color: Light gray
Front panel	Membrane sheet
Indicating structure	
Displays	Upper display, Lower display: 4-digit Red LED, Character size: 7.4 x 4 mm (H x W)
Status indicator	PWR indicator (Yellow): Lit when power to the SIF-600 is turned ON. ERR indicator (Red): Lit when communication errors occur. PLC indicator (Yellow): Lit while in Serial communication TX output (transmitting) with the PLC. LOC indicator (Yellow): Lit while in Serial communication TX output (transmitting) with the digital indicating controllers.
Setting structure	Increase Key: Increases the numeric value, or switches the selection item. Decrease Key: Decreases the numeric value, or switches the selection item. Mode Key: Selects a setting mode, or registers the set (or selected) value.

Functions

Controller communication function									
Communication line	RS-485								
Communication method	Half-duplex communication								
Communication speed	9600, 19200, 38400 bps (Default: 9600 bps)								
Synchronization method	Start-stop synchronization								
Data format	<table border="1"> <tr> <td>Start bit</td> <td>1 bit</td> </tr> <tr> <td>Data length</td> <td>7 bits, 8 bits (Default: 7 bits)</td> </tr> <tr> <td>Parity</td> <td>No parity, Even, Odd (Default: Even)</td> </tr> <tr> <td>Stop bit</td> <td>1 bit, 2 bits (Default: 1 bit)</td> </tr> </table>	Start bit	1 bit	Data length	7 bits, 8 bits (Default: 7 bits)	Parity	No parity, Even, Odd (Default: Even)	Stop bit	1 bit, 2 bits (Default: 1 bit)
Start bit	1 bit								
Data length	7 bits, 8 bits (Default: 7 bits)								
Parity	No parity, Even, Odd (Default: Even)								
Stop bit	1 bit, 2 bits (Default: 1 bit)								
Connectable controllers	Controllers with Shinko protocol, Modbus protocol (ASCII, RTU)								

PLC communication function	Communicates with the PLC selected in Parameter setting mode.																																									
Communication line	RS-232C, RS-485, RS-422A RS-422A: Built-in terminator (200 Ω) between RXA and RXB																																									
Communication method	Half-duplex communication																																									
Communication speed	9600, 19200, 38400 bps (Default: 9600 bps)																																									
Synchronization method	Start-stop synchronization																																									
Data format	<table border="1"> <tr> <td>Start bit</td> <td colspan="2">1 bit</td> </tr> <tr> <td>Data length</td> <td colspan="2">7 bits, 8 bits (Default: 7 bits)</td> </tr> <tr> <td>Parity</td> <td colspan="2">No parity, Even, Odd (Default: Even)</td> </tr> <tr> <td>Stop bit</td> <td colspan="2">1 bit, 2 bits (Default: 1 bit)</td> </tr> </table>			Start bit	1 bit		Data length	7 bits, 8 bits (Default: 7 bits)		Parity	No parity, Even, Odd (Default: Even)		Stop bit	1 bit, 2 bits (Default: 1 bit)																												
Start bit	1 bit																																									
Data length	7 bits, 8 bits (Default: 7 bits)																																									
Parity	No parity, Even, Odd (Default: Even)																																									
Stop bit	1 bit, 2 bits (Default: 1 bit)																																									
PLC model	Selects a PLC (manufacturer, model) in Parameter setting mode. <table border="1"> <thead> <tr> <th>PLC manufacturer</th> <th>Model</th> <th>Register</th> <th>Comm. command</th> </tr> </thead> <tbody> <tr> <td rowspan="2">Mitsubishi Electric Corp.</td> <td>MELSEC</td> <td>D register</td> <td>QR/QW</td> </tr> <tr> <td>MELSEC</td> <td>R register</td> <td>QR/QW</td> </tr> <tr> <td>Omron Corp.</td> <td>SYSMAC</td> <td>DM register</td> <td>RD/WR</td> </tr> <tr> <td>Keyence Corp.</td> <td>KV</td> <td>DM register</td> <td>RDS/WRS</td> </tr> <tr> <td>Yokogawa Electric Corp.</td> <td>FA-M3</td> <td>D register</td> <td>WRD/WWR</td> </tr> <tr> <td>Fuji Electric Co., Ltd.</td> <td>MICREX</td> <td>Standard memory</td> <td>Loader</td> </tr> </tbody> </table> <p>Host link unit</p> <table border="1"> <thead> <tr> <th>PLC manufacturer</th> <th>Model</th> </tr> </thead> <tbody> <tr> <td rowspan="2">Mitsubishi Electric Corp.</td> <td>AJ71UC24, A1SJ71UC24-R2/R4/PRF A1SJ71C24-R2/R4/PRF, QJ71C24</td> </tr> <tr> <td>Omron Corp.</td> <td>CS1W-SCU21-V1 CJ1W-SCU21, CJ1W-SCU41</td> </tr> <tr> <td>Keyence Corp.</td> <td>KV-L20V</td> </tr> <tr> <td>Yokogawa Electric Corp.</td> <td>F3LC11-2N, F3LC11-1F, F3LC12-1F</td> </tr> <tr> <td>Fuji Electric Co., Ltd.</td> <td>NP1L-RS1, NP1L-RS2, NP1L-RS3 NP1L-RS4</td> </tr> </tbody> </table>			PLC manufacturer	Model	Register	Comm. command	Mitsubishi Electric Corp.	MELSEC	D register	QR/QW	MELSEC	R register	QR/QW	Omron Corp.	SYSMAC	DM register	RD/WR	Keyence Corp.	KV	DM register	RDS/WRS	Yokogawa Electric Corp.	FA-M3	D register	WRD/WWR	Fuji Electric Co., Ltd.	MICREX	Standard memory	Loader	PLC manufacturer	Model	Mitsubishi Electric Corp.	AJ71UC24, A1SJ71UC24-R2/R4/PRF A1SJ71C24-R2/R4/PRF, QJ71C24	Omron Corp.	CS1W-SCU21-V1 CJ1W-SCU21, CJ1W-SCU41	Keyence Corp.	KV-L20V	Yokogawa Electric Corp.	F3LC11-2N, F3LC11-1F, F3LC12-1F	Fuji Electric Co., Ltd.	NP1L-RS1, NP1L-RS2, NP1L-RS3 NP1L-RS4
PLC manufacturer	Model	Register	Comm. command																																							
Mitsubishi Electric Corp.	MELSEC	D register	QR/QW																																							
	MELSEC	R register	QR/QW																																							
Omron Corp.	SYSMAC	DM register	RD/WR																																							
Keyence Corp.	KV	DM register	RDS/WRS																																							
Yokogawa Electric Corp.	FA-M3	D register	WRD/WWR																																							
Fuji Electric Co., Ltd.	MICREX	Standard memory	Loader																																							
PLC manufacturer	Model																																									
Mitsubishi Electric Corp.	AJ71UC24, A1SJ71UC24-R2/R4/PRF A1SJ71C24-R2/R4/PRF, QJ71C24																																									
	Omron Corp.	CS1W-SCU21-V1 CJ1W-SCU21, CJ1W-SCU41																																								
Keyence Corp.	KV-L20V																																									
Yokogawa Electric Corp.	F3LC11-2N, F3LC11-1F, F3LC12-1F																																									
Fuji Electric Co., Ltd.	NP1L-RS1, NP1L-RS2, NP1L-RS3 NP1L-RS4																																									
PLC memory allocation method	<table border="1"> <thead> <tr> <th>PLC memory allocation</th> <th>Contents</th> </tr> </thead> <tbody> <tr> <td>Flexible address method</td> <td>Constantly updates RO (Read Only) data items. Manages RW (Read/Write) data item settings with the Set value change flag.</td> </tr> <tr> <td>Multi address method</td> <td>Block communication command (multiple data communication command in Modbus protocol) is available. Constantly updates RO (Read Only) data items. Manages RW (Read/Write) data item settings with the Set value change flag.</td> </tr> <tr> <td>Flagless method</td> <td>Constantly updates RO (Read Only) data items. Manages RW (Read/Write) data item settings without using the Set value change flag.</td> </tr> <tr> <td>Fixed address method</td> <td>20 units are fixed in the PLC register section. Constantly updates RO (Read Only) data items. Manages RW (Read/Write) data item settings with the Set value change flag.</td> </tr> </tbody> </table>			PLC memory allocation	Contents	Flexible address method	Constantly updates RO (Read Only) data items. Manages RW (Read/Write) data item settings with the Set value change flag.	Multi address method	Block communication command (multiple data communication command in Modbus protocol) is available. Constantly updates RO (Read Only) data items. Manages RW (Read/Write) data item settings with the Set value change flag.	Flagless method	Constantly updates RO (Read Only) data items. Manages RW (Read/Write) data item settings without using the Set value change flag.	Fixed address method	20 units are fixed in the PLC register section. Constantly updates RO (Read Only) data items. Manages RW (Read/Write) data item settings with the Set value change flag.																													
PLC memory allocation	Contents																																									
Flexible address method	Constantly updates RO (Read Only) data items. Manages RW (Read/Write) data item settings with the Set value change flag.																																									
Multi address method	Block communication command (multiple data communication command in Modbus protocol) is available. Constantly updates RO (Read Only) data items. Manages RW (Read/Write) data item settings with the Set value change flag.																																									
Flagless method	Constantly updates RO (Read Only) data items. Manages RW (Read/Write) data item settings without using the Set value change flag.																																									
Fixed address method	20 units are fixed in the PLC register section. Constantly updates RO (Read Only) data items. Manages RW (Read/Write) data item settings with the Set value change flag.																																									

Setup communication	Sets up the SIF-600 using the console software, and transmits the data. To connect the SIF-600 to a PC, use the USB communication cable CMB-001, and connect it to the Consol communication connector on the front panel of the SIF-600.
OS	Windows XP, Windows Vista, Windows 7
Communication line	TTL level
Protocol	Shinko protocol
Communication method	Half-duplex communication
Communication speed	19200 bps (Fixed)
Synchronization method	Start-stop synchronization

Insulation, Dielectric Strength

Circuit insulation configuration	<pre> graph TD PS[Power supply] --- EI1[Electrically insulated] EI1 --- CPU[CPU] CPU --- EI2[Electrically insulated] EI2 --- COM_LOCAL[Communication (LOCAL)] COM_PLC[Communication (PLC)] --- EI1 </pre>
Insulation resistance	10 MΩ or more, at 500 V DC
Dielectric strength	1.5 kV AC for 1 minute Power terminal – Communication (LOCAL) terminal Power terminal – Communication (PLC) terminal Communication (PLC) terminal – Communication (LOCAL) terminal

Attached Functions

Display-OFF function	By setting the indication time in Communication mode, displays are turned OFF if operation does not take place for the time set in [Indication time]. If any key is pressed, displays will be turned ON again. If indication time is set to 0 (zero), continuous indication will occur, and this function will be disabled.
Auto-light function	Automatically measures and controls brightness of the displays and status indicators.

Other

Power consumption	Approx. 7 VA			
Ambient temperature	0 to 50 °C (32 to 122 °F)			
Ambient humidity	35 to 85 %RH (non-condensing)			
Weight	Approx. 180 g (including the socket)			
Accessories included	Instruction manual 1 copy			
Accessories sold separately	<table border="1"> <tr> <td rowspan="2">Socket</td> <td>ASK-001-1 (Finger-safe, Ring terminals unusable)</td> </tr> <tr> <td>ASK-002-1 (Ring terminals usable)</td> </tr> </table>	Socket	ASK-001-1 (Finger-safe, Ring terminals unusable)	ASK-002-1 (Ring terminals usable)
Socket	ASK-001-1 (Finger-safe, Ring terminals unusable)			
	ASK-002-1 (Ring terminals usable)			
Environment specification	RoHS directive conformance			

9. Troubleshooting

If any malfunctions occur, refer to the following items after checking the power is being supplied to the SIF-600, PLC and Digital indicating controllers.

9.1 Communication

Problem	Presumed Cause and Solution
Communication failure	Make sure that the communication connector is securely connected.
	Burnout or imperfect contact on the communication cable and the connector. Securely connect the connector. Change the cable.
	Wiring of the communication cable (connector) is not correct. Refer to the following sections. 5.4 Connecting to a PLC (Pages 16 to 21) 5.5 Connecting to Digital Indicating Controllers (Pages 22 to 25)
	Setup of the SIF-600 is not correct. Refer to the following sections. 6.2 Setup via Console Software (Pages 27 to 57) 6.3 Setup in Parameter Setting Mode (Pages 58 to 62)
	Setup of the PLC (host link unit) is not correct. Refer to the following section. 6.4 Setup of the PLC (Pages 63 to 73)
	Setup of the digital indicating controllers is not correct. Refer to the following section. 6.5 Setup of Digital Indicating Controllers (p.73)
	The instrument numbers of the controllers are duplicated. Refer to the following section. 6.5 Setup of Digital Indicating Controllers (p.73) If the Fixed address method is selected in [PLC memory allocation method] via the console software, the instrument number of the controllers should be consecutive from 0 to 19.

9.2 Indication

Problem	Presumed Cause and Solution										
Displays are unlit.	The time set in [Indication time (p.62)] has passed. If any key is pressed while displays are unlit, they will re-light. Set the indication time to a suitable time-frame.										
Displays are dark.	\overline{L} \overline{E} (Enabled) is selected in [Auto-light function (p.62)]. Select \overline{L} \overline{E} (Disabled).										
\overline{E} is flashing on the 'ones' digit of the Upper display.	Communication errors have occurred while communicating with the controllers. Communication error codes are shown below. Check the specifications of the SIF-600 and controllers based on the error codes indicated on the 'ones' digit of the Lower display. Communication error codes on the controller side: <table border="1" data-bbox="504 1572 1190 1754"> <thead> <tr> <th>Communication error code</th> <th>Contents</th> </tr> </thead> <tbody> <tr> <td>1</td> <td>Parity error</td> </tr> <tr> <td>2</td> <td>Negative acknowledgement</td> </tr> <tr> <td>4</td> <td>Sum error</td> </tr> <tr> <td>5</td> <td>No response</td> </tr> </tbody> </table> $\overline{3}$, $\overline{6}$: Reserved	Communication error code	Contents	1	Parity error	2	Negative acknowledgement	4	Sum error	5	No response
Communication error code	Contents										
1	Parity error										
2	Negative acknowledgement										
4	Sum error										
5	No response										

Problem	Presumed Cause and Solution								
<p>Ē is flashing on the 'tens' digit of the Upper display.</p>	<p>Communication errors have occurred while communicating with the PLC.</p> <p>Communication error codes are shown below. Check the specifications of the SIF-600 and controllers based on the error codes indicated on the 'ones' digit of the Lower display.</p> <p>Communication error codes on the PLC side:</p> <table border="1" data-bbox="504 301 1063 446"> <thead> <tr> <th data-bbox="504 301 847 336">Communication error code</th> <th data-bbox="847 301 1063 336">Contents</th> </tr> </thead> <tbody> <tr> <td data-bbox="504 336 847 370">1</td> <td data-bbox="847 336 1063 370">Parity error</td> </tr> <tr> <td data-bbox="504 370 847 405">4</td> <td data-bbox="847 370 1063 405">Sum error</td> </tr> <tr> <td data-bbox="504 405 847 440">5</td> <td data-bbox="847 405 1063 440">No response</td> </tr> </tbody> </table> <p>2, 3, 6: Reserved</p>	Communication error code	Contents	1	Parity error	4	Sum error	5	No response
Communication error code	Contents								
1	Parity error								
4	Sum error								
5	No response								

10. Character Table

Upper display	Setting item	Factory default value	Data
<i>c-āā</i>	PLC memory allocation method <i>Fb</i> <input type="checkbox"/> : Flexible address method <i>āR</i> <input type="checkbox"/> : Multi address method <i>FL</i> <input type="checkbox"/> : Flagless method <i>FY</i> <input type="checkbox"/> : Fixed address method	Fixed address method	
<i>c-ād</i>	Controller communication protocol <i>4H1n</i> : Shinko protocol <i>āodR</i> : Modbus ASCII <i>āodr</i> : Modbus RTU	Shinko protocol	
<i>c-4P</i>	Controller communication speed <input type="checkbox"/> 96 : 9600 bps <input type="checkbox"/> 192 : 19200 bps <input type="checkbox"/> 384 : 38400 bps	9600 bps	
<i>c-dR</i>	Controller data length <i>7bit</i> : 7 bits <i>8bit</i> : 8 bits	7 bits	
<i>c-Pr</i>	Controller parity <i>nonE</i> : No parity <i>EEn</i> : Even <i>odd</i> <input type="checkbox"/> : Odd	Even	
<i>c-4f</i>	Controller stop bit <i>1bit</i> : 1 bit <i>2bit</i> : 2 bits	1 bit	
<i>P-f</i> <input type="checkbox"/>	PLC model <i>ā</i> <input type="checkbox"/> <i>d</i> : Mitsubishi Electric Corp. MELSEC D register QR/QW command <i>ā</i> <input type="checkbox"/> <i>r</i> : Mitsubishi Electric Corp. MELSEC R register QR/QW command <i>a</i> <input type="checkbox"/> <input type="checkbox"/> <input type="checkbox"/> : Omron Corp. SYSMAC CJ series <i>k</i> <input type="checkbox"/> <input type="checkbox"/> <input type="checkbox"/> : Keyence Corp. KV <i>y</i> <input type="checkbox"/> <input type="checkbox"/> <input type="checkbox"/> : Yokogawa Electric Corp. FA-M3 <i>F</i> <input type="checkbox"/> <input type="checkbox"/> <input type="checkbox"/> : Fuji Electric Co., Ltd. MICREX-SX series	Mitsubishi MELSEC D register QR/QW command	
<i>P-R</i> <input type="checkbox"/>	PLC instrument number 0 to 99	0	
<i>P-4P</i>	PLC communication speed <input type="checkbox"/> 96 : 9600 bps <input type="checkbox"/> 192 : 19200 bps <input type="checkbox"/> 384 : 38400 bps	9600 bps	

Upper display	Setting item	Factory default value	Data
P-dR	PLC data length 7bit : 7 bits 8bit : 8 bits	7 bits	
P-Pr	PLC parity nonE : No parity EEEn : Even odd : Odd	Even	
P-4f	PLC stop bit 1bit : 1 bit 2bit : 2 bits	1 bit	
FY-c	Controller connected units 1 to 20 units	1 unit	
FY-R	Reference address 0000H to FFDCH (0 to 65500)	03E8H (1000)	
LI OF	Auto-light function OFF : Disabled ON : Enabled	Disabled	
FI nE	Indication time 00.00 (Remains lit) 00.01 to 60.00 (Minutes.Seconds)	00.00 (Remains lit)	

***** Inquiries *****

For any inquiries about this unit, please contact our agency or the vendor where you purchased the unit after checking the following.

[Example]

- Model ----- SIF-600
- Serial number ----- No. 11XF05000

In addition to the above, please let us know the details of the malfunction, if any, and the operating conditions.

SHINKO TECHNOS CO.,LTD. OVERSEAS DIVISION

Head Office : 2-5-1, Senbahigashi, Minoo, Osaka, Japan

URL: <http://www.shinko-technos.co.jp>

E-mail: overseas@shinko-technos.co.jp

Tel : 81-72-727-6100

Fax: 81-72-727-7006