

SB series

SPEC. SHEET

Current Loop Supply

Model: **SBD**

■ Features

- Simple wiring using a plug-in socket
- Compact
- 3-port insulation (Input-Output-Power)

■ Model

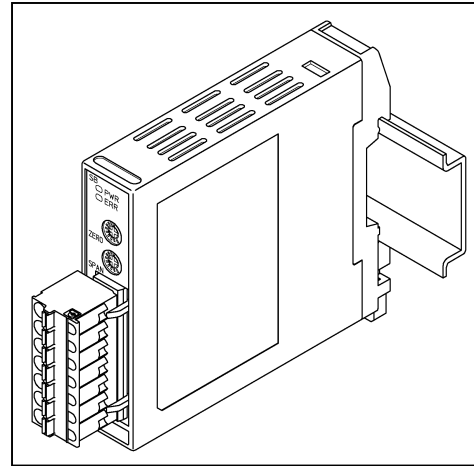
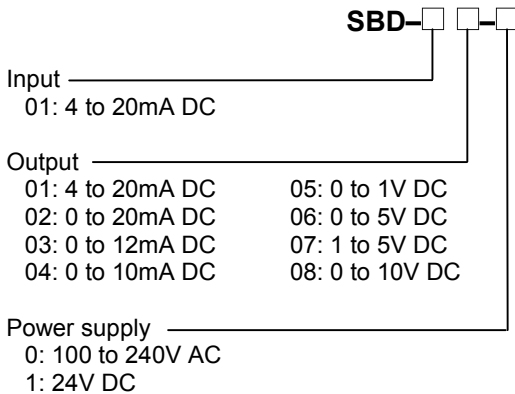

■ How to order

Specify a model.
(e.g.) SBD-0101-0

■ Input specifications

DC current: 4 to 20mA DC
Shunt resistor: 50Ω built-in

■ Output specifications

When the output range lower limit is zero, (even if zero adjustment results in a negative value), output value will not indicate a negative value.

DC current

Output range	Allowable load resistance	Zero adjustment range	Span adjustment range
4 to 20mA DC	600Ω or more	-2.5 to 2.5%	97.5 to 102.5%
0 to 20mA DC	600Ω or more	0 to 2.5%	97.5 to 102.5%
0 to 12mA DC	1kΩ or less	0 to 2.5%	97.5 to 102.5%
0 to 10mA DC	1kΩ or less	0 to 2.5%	97.5 to 102.5%

DC voltage

Output range	Allowable load resistance	Zero adjustment range	Span adjustment range
0 to 1V DC	100Ω or more	0 to 2.5%	97.5 to 102.5%
0 to 5V DC	500Ω or more	0 to 2.5%	97.5 to 102.5%
1 to 5V DC	500Ω or more	-2.5 to 2.5%	97.5 to 102.5%
0 to 10V DC	1kΩ or more	0 to 2.5%	97.5 to 102.5%

■ 2-wire transmitter power supply

Output voltage : 24 ± 3V DC (when load current is 20mA)
Ripple voltage : 200mV DC or less (when load current is 20mA)

Max. load current: 25mA DC

■ Performance

Accuracy : Within ±0.2%
Response time : 1 sec. (0 → 90%)
(Average 0.5 sec)
Temperature coefficient: ±0.015%/°C
Insulation resistance : 10MΩ or more, at 500V DC
(Input-Output-Power)
Dielectric strength : 2.0kV AC for 1 minute
(Input-Output-Power)

Note: Input terminals: 1, 2, 3 (Power supply for 2-wire transmitter included)

Instrument specifications

Case : Flame resistant resin Color: Light gray
 Front panel : Polycarbonate
 Spring type plug: Polyamide Color: Green
 Adjustment: By the front potentiometer
 Zero adjustment : $\pm 2.5\%$
 Span adjustment : $\pm 2.5\%$
 Indication:
 Power indicator (PWR): Green
 Lights when the power is turned on.
 Flashes in 500ms cycles when an error has occurred in non-volatile IC memory.
 Error indicator (ERR): Red
 Flashes in 250ms cycles when input is 110% or more.
 Flashes in 500ms cycles when input is -10% or less.
 Output status selection: Selects Normal or Reverse with the DIP switch.
 No.1 OFF: Normal, ON: Reverse
 Momentary power failure: 30msec.
 Self diagnosis:
 The CPU is monitored by a watchdog timer, and when an abnormal status is found on the CPU, the unit restarts with the reset action.

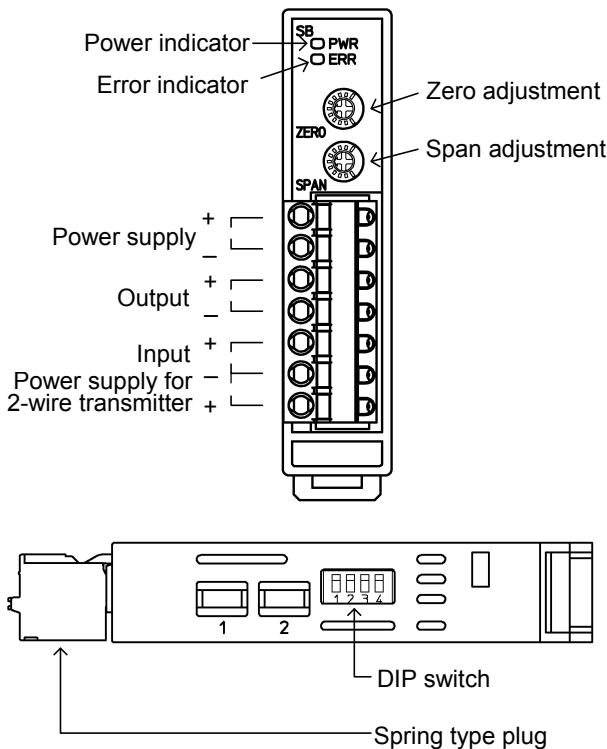

Installation specifications

Power supply
 • 100 to 240V AC 50/60Hz
 Allowable voltage range: 85 to 264V AC
 Power consumption : Approx. 3.5VA
 • 24V DC
 Allowable voltage range: 20 to 28V DC
 Power consumption : Approx. 3.5W
 Ambient temperature: -5 to 55°C
 Ambient humidity : 35 to 85%RH (non-condensing)
 Weight : Approx. 80g

Mounting method : DIN rail mounting
 Be sure to use fastening plates at both ends of the unit after the unit is mounted to the DIN rail.
 External dimensions : 17.5 (W) x 75 (H) x 85 (D) mm

Environmental specification

RoHS directive compliance

Ferrules

Made by Phoenix Contact GMBH & CO.

Insulation sleeve attached

Model	Conductor cross section
AI0.25-6BU	0.2 – 0.25mm ²
AI0.34-8TQ	0.25 – 0.34mm ²
AI0.5-8WH	0.34 – 0.5mm ²
AI0.75-8GY	0.5 – 0.75mm ²
AI1-8RD	0.75 – 1.0mm ²
AI1.5-8BK	1.0 – 1.5mm ²
AI2.5-8BU	1.5 – 2.5mm ²

Crimping pliers
 CRIMPFOX ZA3
 CRIMPFOX UD6

Circuit configuration, terminal arrangement

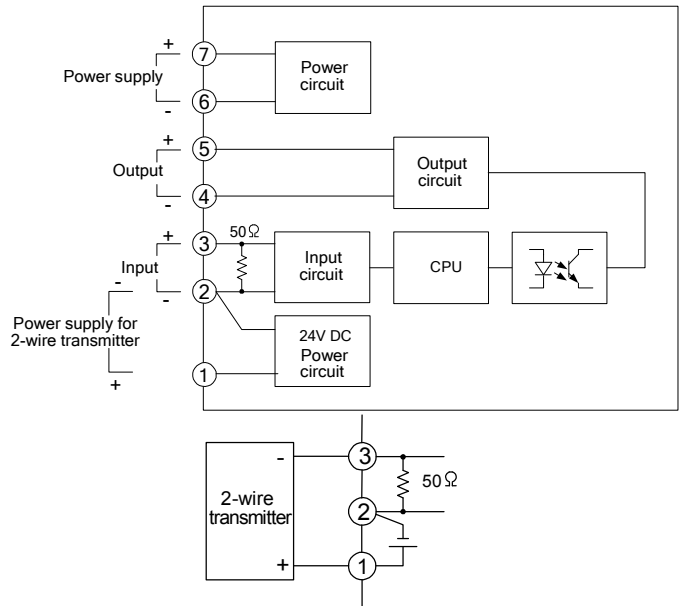

External dimensions (Scale: mm)

