

Isolator (with indication function)

Model: **SE2A**

Model

SE2A - □ - □

Socket

- 1: Finger-safe  
(For Y terminal)
- 2: For Ring terminal

Power supply

- 0: 100 to 240V AC
- 1: 24V AC/DC

How to order

Specify the model (e.g.) SE2A-1-0

Default value

CH1 input	4 to 20mA DC
CH2 input	4 to 20mA DC
CH1 output	4 to 20mA DC
CH2 output	4 to 20mA DC

Accessories (sold separately)

Name		Model	Spec.
Shunt resistor	Ring terminal	RES-S01-050	50Ω ±0.1%
		RES-S01-100	100Ω ±0.1%
		RES-S01-200	200Ω ±0.1%
		RES-S01-01K	1kΩ ±0.1%
	Y terminal	RES-S06-050	50Ω ±0.1%
		RES-S06-100	100Ω ±0.1%
		RES-S06-200	200Ω ±0.1%
		RES-S06-01K	1kΩ ±0.1%

Communication cable for the console software: CMB-001

Input specification

DC current

Connect a shunt resistor (sold separately) between input terminals.

Input	Shunt resistor
4 to 20mA DC	50Ω
0 to 20mA DC	
0 to 16mA DC	
2 to 10mA DC	100Ω
0 to 10mA DC	
1 to 5mA DC	200Ω
0 to 1mA DC	1kΩ

Output specification

When the output range lower limit is zero, (even if zero adjustment results in a negative value), the output value will not be negative.

DC current

Output range	Allowable load resistance	Zero adjustment range	Span adjustment range
4 to 20mA DC	700Ω or less	-5 to 5%	95 to 105%
0 to 20mA DC	700Ω or less	0 to 5%	95 to 105%
0 to 12mA DC	1.2kΩ or less	0 to 5%	95 to 105%
0 to 10mA DC	1.2kΩ or less	0 to 5%	95 to 105%
1 to 5mA DC	2.4kΩ or less	-5 to 5%	95 to 105%

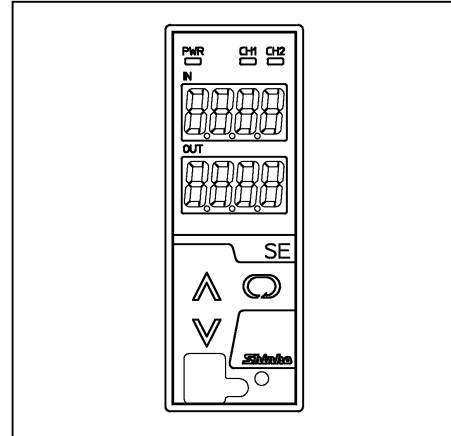

DC voltage

Output range	Allowable load resistance	Zero adjustment range	Span adjustment range
0 to 1V DC	100Ω or more	0 to 5%	95 to 105%
0 to 5V DC	500Ω or more	0 to 5%	95 to 105%
1 to 5V DC	500Ω or more	-5 to 5%	95 to 105%
0 to 10V DC	1kΩ or more	0 to 5%	95 to 105%

Performance

Accuracy (When ambient temperature is 23°C):

Input: Within ±0.1%

Output: Within ±0.1%

Indication accuracy: Within input accuracy ±1 digit

Input sampling period: 25ms, 125ms, 250ms (Selectable by keypad)

Response time: 65ms (typ.) (0→90%) (Input sampling period 25ms)

225ms (typ.) (0→90%) (Input sampling period 125ms)

425ms (typ.) (0→90%) (Input sampling period 250ms)

(Selectable by keypad)

Temperature coefficient: ±0.015%/°C or less

Insulation resistance: 10MΩ or more, at 500V DC

(Input – Output – Power supply)

Dielectric strength: 2.0kV AC for 1 minute

(Input – Output – Power supply)

**General structure**

Case: Flame-resistant resin, Color: Light gray  
 Front panel: Membrane sheet  
 Setting: By the front keypad  
 Connector for console software: Only for CMB-001  
 Indication: Input display: 7-segment, Red LED display 4-digit  
 Character size 10×4.6mm (H×W)  
 Output display: 7-segment, Red LED display 4-digit  
 Character size 10×4.6mm (H×W)  
 Power indicator: Green LED  
 CH1 indicator: Yellow LED  
 CH2 Indicator: Yellow LED

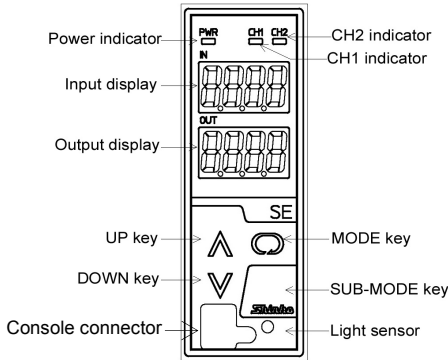

**Installation specifications**

Power supply: 100 to 240V AC 50/60Hz, 24V AC/DC 50/60Hz  
 Allowable voltage range: 85 to 264V AC, 20 to 28V AC/DC  
 Power consumption: Approx. 8VA  
 Ambient temperature: -5 to 55°C  
 Ambient humidity: 35 to 85%RH (Non-condensing)  
 Mounting: DIN rail mounting  
 External dimensions: W30×H88×D108mm (including the socket)  
 Weight: Approx. 190g (including the socket)

**Attached functions**

Auto-light function: Display brightness is controlled in accordance with the surrounding area. Unnecessary brightness is reduced, saving energy.  
 Power failure countermeasure: The data is backed up in non-volatile IC memory.  
 Self diagnosis: The CPU is monitored by a watchdog timer, and when an abnormal status is found on the CPU, the unit is switched to warm-up status with tuning all outputs off.

**Environmental specification**

RoHS directive compliance

**Settings**

Function keys

- (1) UP Key: Increases the numeric value.
  - (2) DOWN Key: Decrease the numeric value.
  - (3) MODE Key: Selects the setting mode.
  - (4) SUB-MODE Key: Turns the displays ON again when they are in OFF status.
- (The UP, DOWN or MODE Key also turns the displays ON again when they are in OFF status.)

**Displays and indicators**

Input display: Indicates the input value  
 Indication of -2000 or less (for DC input):  
 The minus (-) sign and input value light alternately.  
 Indication of 10000 or more:  
 The lower 4 digits flash.  
 Under range: “- - - -” flashes on the input display.  
 Over range: “- - - -” flashes on the input display  
 Warm-up indication: For approx. 3sec. after the power to the instrument is turned on, the input type of CH1 is indicated on the input display, the input type of CH2 is indicated on the output display.  
 Output display: Indicates output volume in percentage (%) form.  
 Power indicator: The green LED lights when the power to the instrument is turned on.  
 CH1 indicator: The yellow LED lights when CH1 is selected during Display selection mode.  
 CH2 indicator: The yellow LED lights when CH2 is selected during Display selection mode.

**Solderless terminal**

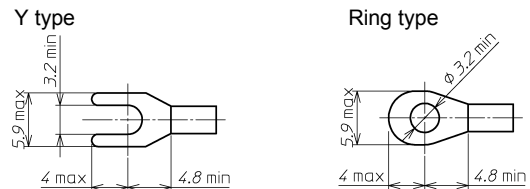

**Circuit configuration and terminal arrangement**

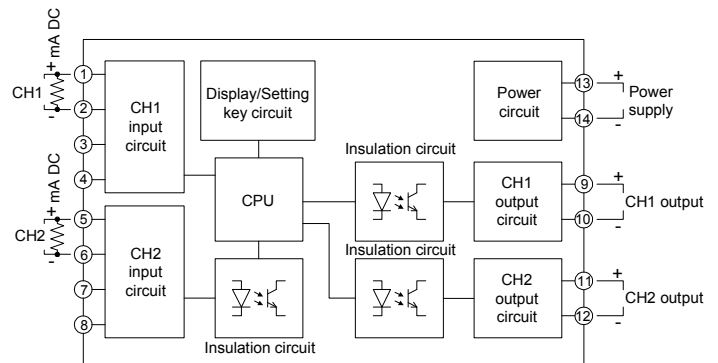

**External dimensions (Scale: mm)**

