

# Thermocouple Transmitter

Model: **SE2E**

(with indication function)

## Model

SE2E - □ - □

### Socket

- 1: Finger-safe  
(For Y terminal)
- 2: For Ring terminal

### Power supply

- 0: 100 to 240V AC
- 1: 24V AC/DC

## How to order

Specify the model (e.g.) SE2E-1-0

### Default value

CH1 input	K: -200 to 1370 °C
CH2 input	K: -200 to 1370 °C
CH1 output	4 to 20mA DC
CH2 output	4 to 20mA DC

## Accessories (sold separately)

Communication cable for the console software: CMB-001

## Input specification

### Thermocouple

Input resistance: 1MΩ or more

External resistor: 100Ω or less, however, B input, 40Ω or less

Burnout: Upscale, Downscale (Selectable by keypad)

### Input

Thermocouple	Input range	
K	-200 to 1370 °C	-328 to 2498 °F
J	-200 to 1000 °C	-328 to 1832 °F
R	-50 to 1760 °C	-58 to 3200 °F
S	-50 to 1760 °C	-58 to 3200 °F
B	0 to 1820 °C	32 to 3308 °F
E	-200 to 800 °C	-328 to 1472 °F
T	-200 to 400 °C	-328 to 752 °F
N	-200 to 1300 °C	-328 to 2372 °F
PL-II	0 to 1390 °C	32 to 2534 °F
W5Re/W26Re	0 to 2315 °C	32 to 4199 °F
W3Re/W25Re	0 to 2315 °C	32 to 4199 °F

Minimum span: 50°C (100°F)

## Output specification

When the output range lower limit is zero, (even if zero adjustment results in a negative value), the output value will not be negative.

### DC current

Output range	Allowable load resistance	Zero adjustment range	Span adjustment range
4 to 20mA DC	700Ω or less	-5 to 5%	95 to 105%
0 to 20mA DC	700Ω or less	0 to 5%	95 to 105%
0 to 12mA DC	1.2kΩ or less	0 to 5%	95 to 105%
0 to 10mA DC	1.2kΩ or less	0 to 5%	95 to 105%
1 to 5mA DC	2.4kΩ or less	-5 to 5%	95 to 105%

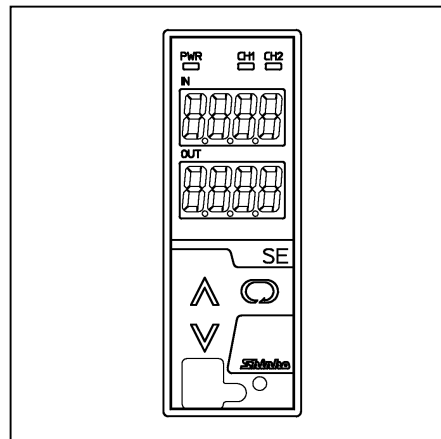

## DC voltage

Output range	Allowable load resistance	Zero adjustment range	Span adjustment range
0 to 1V DC	100Ω or more	0 to 5%	95 to 105%
0 to 5V DC	500Ω or more	0 to 5%	95 to 105%
1 to 5V DC	500Ω or more	-5 to 5%	95 to 105%
0 to 10V DC	1kΩ or more	0 to 5%	95 to 105%

## Performance

Accuracy (When ambient temperature is 23°C):

Input:

- Within ±0.1% of each input span, however,
- R, S input, -50 to 200°C (-58 to 392°F): Within ±6°C (12°F)
- B input, 0 to 300°C (32 to 572°F): Accuracy is not guaranteed.
- K, J, E, T, N input, less than 0°C (32°F):

Within ±0.4% of each input span

Output: Within ±0.1%

Cold junction compensation accuracy: Within ±1°C at -5 to 55°C

Indication accuracy: Within input accuracy ±1 digit

Input sampling period: 25ms, 125ms, 250ms (Selectable by keypad)

Response time: 65ms (typ.) (0→90%) (Input sampling period 25ms)

225ms (typ.) (0→90%) (Input sampling period 125ms)

425ms (typ.) (0→90%) (Input sampling period 250ms)

(Selectable by keypad)

Temperature coefficient: ±0.015%/°C or less

Insulation resistance: 10MΩ or more, at 500V DC

(Input – Output – Power supply)

Dielectric strength: 2.0kV AC for 1 minute

(Input – Output – Power supply)

**General structure**

Case: Flame-resistant resin, Color: Light gray  
 Front panel: Membrane sheet  
 Setting: By the front keypad  
 Connector for console software: Only for CMB-001  
 Indication: Input display: 7-segment, Red LED display 4-digit  
 Character size 10×4.6mm (H×W)  
 Output display: 7-segment, Red LED display 4-digit  
 Character size 10×4.6mm (H×W)  
 Power indicator: Green LED  
 CH1 indicator: Yellow LED  
 CH2 Indicator: Yellow LED

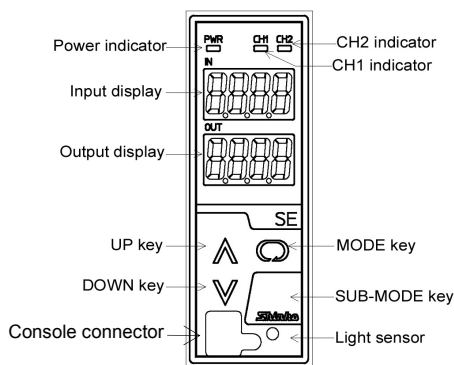

**Displays and indicators**

Input display: Indicates the input value  
 Indication of -200.0 or less (for the range with decimal point):  
 The minus (-) sign and input value light alternately.  
 Under range: “- - - -” flashes on the input display.  
 Over range: “- - - -” flashes on the input display  
 Warm-up indication: For approx. 3sec. after the power to the instrument is turned on, the input type of CH1 is indicated on the input display, the input type of CH2 is indicated on the output display.  
 Output display: Indicates output volume in percentage (%) form.  
 Power indicator: The green LED lights when the power to the instrument is turned on.  
 CH1 indicator: The yellow LED lights when CH1 is selected during Display selection mode.  
 CH2 indicator: The yellow LED lights when CH2 is selected during Display selection mode.

**Solderless terminal**

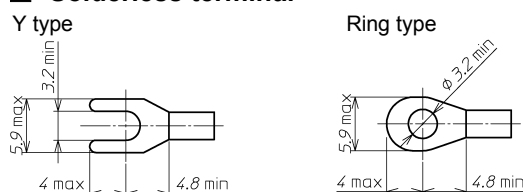

**Installation specifications**

Power supply: 100 to 240V AC 50/60Hz, 24V AC/DC 50/60Hz  
 Allowable voltage range: 85 to 264V AC, 20 to 28V AC/DC  
 Power consumption: Approx. 8VA  
 Ambient temperature: -5 to 55°C  
 Ambient humidity: 35 to 85%RH (Non-condensing)  
 Mounting: DIN rail mounting  
 External dimensions: W30×H88×D108mm (including the socket)  
 Weight: Approx. 190g (including the socket)

**Attached functions**

Auto-light function: Display brightness is controlled in accordance with the surrounding area. Unnecessary brightness is reduced, saving energy.  
 Power failure countermeasure: The data is backed up in non-volatile IC memory.  
 Self diagnosis: The CPU is monitored by a watchdog timer, and when an abnormal status is found on the CPU, the unit is switched to warm-up status with tuning all outputs off.  
 Cold junction compensation: Available

**Environmental specification**

RoHS directive compliance

**Settings**

Function keys  
 (1) UP Key: Increases the numeric value.  
 (2) DOWN Key: Decrease the numeric value.  
 (3) MODE Key: Selects the setting mode.  
 (4) SUB-MODE Key: Turns the displays ON again when they are in OFF status.  
 (The UP, DOWN or MODE Key also turns the displays ON again when they are in OFF status.)

**Circuit configuration and terminal arrangement**

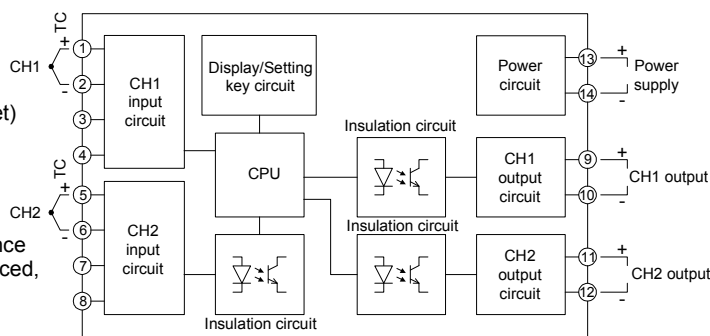

**External dimensions (Scale: mm)**

